

Montgomery County Historic Preservation

Staff Report

<p>ADDRESS: 10309 Freeman Place, Kensington</p> <p>RESOURCE: Kensington Historic District</p> <p>APPLICANT: Susan Brown</p> <p>REVIEW: HAWP</p> <p>CASE NO.: 1152939</p> <p>PROPOSAL: Window and door replacement</p>	<p>MEETING DATE: 5/13/2026</p> <p>REPORT DATE: 5/6/2026</p> <p>PUBLIC NOTICE: 4/29/2026</p> <p>TAX CREDIT ELIGIBLE: No</p> <p>STAFF: Laura DiPasquale</p>
---	--

Staff Recommendation

Staff recommends the HPC approve the HAWP application.

Architectural Description

Significance: Secondary Resource within the Kensington Historic District

Date: 1988

Style: Modern Victorian

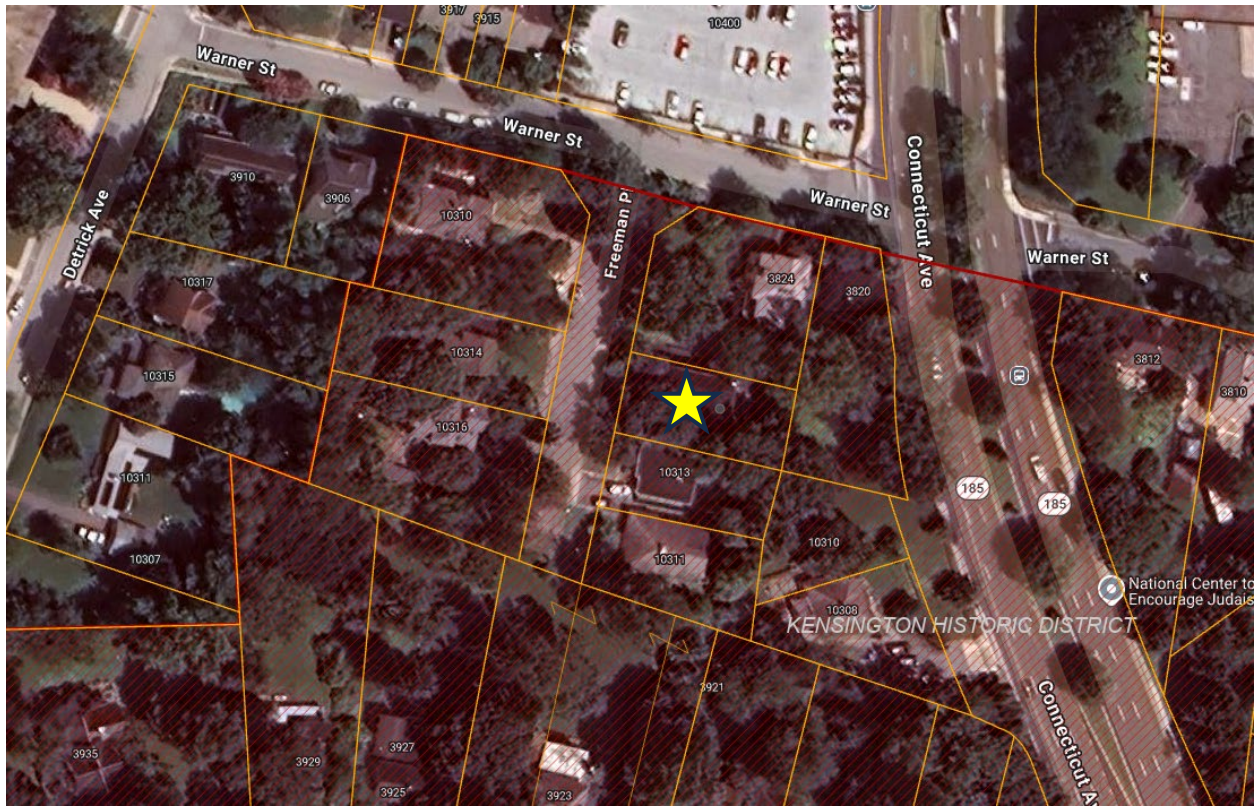

Figure 1: The location of the subject property (shown with a yellow star) in the Kensington Historic District.

Proposal

The applicant proposes to replace one set of first-floor rear sliding patio doors and two second-floor rear windows in existing openings. The new patio doors would be Renewal by Andersen 200 Series vinyl gliding doors and the new windows would be Renewal by Andersen Fibrex Acclaim series double-hungs.



Figure 2: The existing patio doors (left) and windows (right) to be replaced.



Figure 3: Birdseye view of the rear of 10309 Freeman Place showing the locations of the proposed door and window replacements.

Applicable Guidelines

When reviewing alterations and new construction within the Brookeville Historic District several documents are to be utilized as guidelines to assist the Commission in developing their decision. These documents include the *Approved & Adopted Amendment to the Master Plan for Historic Preservation: Kensington Historic District, Atlas #31/6 (Amendment)*; *Vision of Kensington: A Long-Range Preservation Plan (Vision)*; *Montgomery County Code Chapter 24A (Chapter 24A)*; and the *Secretary of the Interior's Standards for Rehabilitation (Standards)*. The pertinent information in these documents is outlined below.

Approved & Adopted Amendment to the Master Plan for Historic Preservation: Kensington Historic District, Atlas #31/6

According to the Guidelines, a Historic District as identified... shall consist of the entire area represented by all of the historic resources with their appurtenances and environmental setting. Non-historic properties within the boundaries of the Historic District are also subject to regulation, as they are considered appurtenances and part of the environmental setting of the historic resources of the District.

Vision of Kensington: A Long-Range Preservation Plan

The HPC formally adopted the planning study, *Vision of Kensington: A Long-Range Preservation Plan*, and is directed by the Executive Regulations, which were approved by the County Council, to use this plan when considering changes and alterations to the Kensington Historic District. The goal of this preservation plan as noted on Page 1 "was to establish a sound database of information from, which to produce a document that would serve the HPC, M-NCPPC, their staff and the community in wrestling with the protection of historic districts amidst the pressures of life in the 21st century." The plan provides a specific physical description of the district as it is; an analysis of character-defining features of the district; a discussion of the challenges facing the district; and a discussion of proposed strategies for maintaining the character of the district while allowing for appropriate growth and change.

Kensington is a suburban community, defined by its curvilinear streets, garden settings, and large, nineteenth century, free-standing residences. Its architecture and planned landscapes exhibit Kensington's late nineteenth century development as a summer retreat from the heat and congestion of Washington...

The Kensington Historic District presents a well-preserved, turn-of-the-century garden suburb. The district is distinguished by its open development pattern, its rich variety of revival architecture, and its historic relationship to the railroad...The residential areas are dominated by engaging free-standing Queen Anne style residences sited within large garden settings.

Montgomery County Code Chapter 24A-8

(b) The commission shall instruct the director to issue a permit, or issue a permit subject to such conditions as are found to be necessary to ensure conformity with the purposes and requirements of this chapter, if it finds that:

- 1) The proposal will not substantially alter the exterior features of an historic site or historic resource within an historic district; or
- 2) The proposal is compatible in character and nature with the historical, archeological, architectural or cultural features of the historic site or the historic district in which an historic resource is located and would not be detrimental thereto or to the achievement of the purposes of this chapter; or

(d) In the case of an application for work on an historic resource located within an historic district, the commission shall be lenient in its judgment of plans for structures of little historical or design significance or for plans involving new construction, unless such plans would seriously impair the historic or architectural value of surrounding historic resources or would impair the character of the historic district. (Ord. No. 9-4, § 1; Ord. No. 11-59.)

Secretary of the Interior's Standards for Rehabilitation

9. New additions, exterior alterations, or related new construction will not destroy historic materials, features, and spatial relationships that characterize the property. The new work will be

differentiated from the old and will be compatible with the historic materials, features, size, scale and proportion, and massing to protect the integrity of the property and its environment.

Staff Discussion

Staff supports the proposed window and door replacement and recommends approval. Staff finds that the subject property includes a c. 1989 faux Victorian house constructed with an approved HAWP after the designation of the Kensington Historic District in 1986 on the site of a Primary Resource. Staff finds that the replacement of the existing rear windows and doors does not constitute the removal of historic materials and will have no impact on the character of the district, per *Standard* 9 and Chapter 24A-8(b)(1) and (d). Staff notes that the proposed Andersen Fibrex windows have traditional profiles and finds that the use of these windows and the proposed 200 series patio doors is appropriate for use on the rear of this non-historic building and in keeping with Chapter 24A-8(b)(2).

106 Family Room 70 1/2 W
79 1/2 H



Patio Door: Gliding , 200 Series Perma-Shield, 2 Panel, Active / Stationary, Aluminum Sill, Exterior White, Interior White
Performance Calculator: PG Rating: 25 | DP Rating: + 25 / - 25
Glass: All Sash: Tempered High Perf. **Hardware:** Newbury® , Bright Brass , Auxiliary Foot Lock Color Matched
Screen: Gliding , Full Screen
Grille Style: No Grille
Misc: Full Frame with Casing Preservation , Contingent Upon Project Manager Approval

201 Primary Bed 43 W
65 H



Window: Acclaim™ Double-Hung (DG) , 1:1, Flat Sill, Insert Frame, Traditional Checkrail, Exterior White, Interior White
Performance Calculator: PG Rating: 40 | DP Rating: + 40 / - 40
Glass: All Sash: High Performance, No Pattern
Hardware: Stone , Standard Color Extra Lock
Screen: Fiberglass , Full Screen
Grille Style: No Grille
Misc: Insert Install Application - Omit Interior Trim , New Interior Trim not needed/desired.

202 Primary Bed 43 W
65 H



Window: Acclaim™ Double-Hung (DG) , 1:1, Flat Sill, Insert Frame, Traditional Checkrail, Exterior White, Interior White
Performance Calculator: PG Rating: 40 | DP Rating: + 40 / - 40
Glass: All Sash: High Performance, No Pattern
Hardware: Stone , Standard Color Extra Lock
Screen: Fiberglass , Full Screen
Grille Style: No Grille
Misc: Insert Install Application - Omit Interior Trim , New Interior Trim not needed/desired.

Figure 4: Specifications for the proposed patio doors and windows.

Staff Recommendation

Staff recommends the HPC approve the HAWP application under the Criteria for Issuance in Chapter 24A-(b)(1) and (2) and (d), having found that the proposal will not substantially alter the exterior features of the historic resource and is compatible in character with the purposes of Chapter 24A;

and the *Vision of Kensington*;

and with the *Secretary of the Interior's Standards for Rehabilitation #9*;

and with the general condition that the applicant shall present an electronic set of drawings, if applicable, to Historic Preservation Commission (HPC) staff for review and stamping prior to submission for the Montgomery County Department of Permitting Services (DPS) building permits;

and with the general condition that final project design details, not specifically delineated by the Commission, shall be approved by HPC staff or brought back to the Commission as a revised HAWP application at staff's discretion;

and with the general condition that the applicant shall notify the Historic Preservation Staff if they propose to make **any alterations** to the approved plans. Once the work is completed the applicant will contact the staff person assigned to this application at 301-495-2167 or laura.dipasquale@montgomeryplanning.org to schedule a follow-up site visit.

Description of Property: Please describe the building and surrounding environment. Include information on significant structures, landscape features, or other significant features of the property:

Residential home

Description of Work Proposed: Please give an overview of the work to be undertaken:

Replace patio door facing back of property, seal of window is broken and threshold is decaying which will allow water to get underneath and cause problems

Replace two master bedroom windows facing back of house for noise control, temperature control and light control

Repairs screens on windows throughout the home 24 screens will be repaired. Repair window in front of house that does not close and repair one window with a broken pane.

Work Item 1: Replace patio door

Description of Current Condition:
Two panel vinyl sliding patio door missing argon gas, frame is decaying especially at threshold.

Proposed Work:
Replace with new full frame double paned vinyl two panel sliding patio door similar to the one we have. Limited lifetime warranty with 10 year labor warranty

Work Item 2: Replace two upstairs windows at back of house

Description of Current Condition:
Two large bedroom windows facing Conn Ave allow road noise and heat coming through the windows

Proposed Work:
See attached for explanation of replacement windows. Windows will be replaced with double hung insert frame.

~~Work Item 3: Repair windows and screens~~

~~Description of Current Condition:
Windows throughout home need various types of repair. Screens need to be repaired and or replaced, broken window pane, two windows in front of house do not close properly and allow air in bedroom~~

~~Proposed Work:
Repair the broken window, repair the screens and their frames, fix and repair windows as needed.~~

No HAWP required for glazing and screen repair

















Proposed

DBA: RENEWAL BY ANDERSEN OF MARYLAND

Legal Name: Renewal by Andersen LLC
 DC-420215000125, VA - 2705155684, MD-155474, MD-154876
 8265 Patuxent Range Road Suite A | Jessup, MD 20794
Jake Chambers (571)241-8918

David Brown
 10309 Freeman Pl
 Kensington, MD 20895
 Year Built: 1989
 (240)447-1363

ID#:	ROOM:	SIZE:	IMAGE:	DETAILS:
106	Family Room	70 1/2 W 79 1/2 H		<p>Patio Door: Gliding , 200 Series Perma-Shield, 2 Panel, Active / Stationary, Aluminum Sill, Exterior White, Interior White Performance Calculator: PG Rating: 25 DP Rating: +25 / - 25 Glass: All Sash: Tempered High Perf. Hardware: Newbury® , Bright Brass , Auxiliary Foot Lock Color Matched Screen: Gliding , Full Screen Grille Style: No Grille Misc: Full Frame with Casing Preservation , Contingent Upon Project Manager Approval</p>
201	Primary Bed	43 W 65 H		<p>Window: Acclaim™ Double-Hung (DG) , 1:1, Flat Sill, Insert Frame, Traditional Checkrail, Exterior White, Interior White Performance Calculator: PG Rating: 40 DP Rating: +40 / - 40 Glass: All Sash: High Performance, No Pattern Hardware: Stone , Standard Color Extra Lock Screen: Fiberglass , Full Screen Grille Style: No Grille Misc: Insert Install Application - Omit Interior Trim , New Interior Trim not needed/desired.</p>
202	Primary Bed	43 W 65 H		<p>Window: Acclaim™ Double-Hung (DG) , 1:1, Flat Sill, Insert Frame, Traditional Checkrail, Exterior White, Interior White Performance Calculator: PG Rating: 40 DP Rating: +40 / - 40 Glass: All Sash: High Performance, No Pattern Hardware: Stone , Standard Color Extra Lock Screen: Fiberglass , Full Screen Grille Style: No Grille Misc: Insert Install Application - Omit Interior Trim , New Interior Trim not needed/desired.</p>
<p>WINDOWS: 2 PATIO DOORS: 1 ENTRY DOORS: 0 SPECIALTY: 0 MISC: 0</p>				



Renewal by Andersen is committed to our customers' safety by complying with the rules and lead-safe work practices specified by the EPA.



RENEWAL
by **ANDERSEN**
FULL-SERVICE WINDOW & DOOR REPLACEMENT

Acclaim™ Replacement Windows Products and Installation Transferable Limited Warranty

Units Installed After June 1, 2024

Renewal by Andersen® Limited Warranty and Dispute Resolution Process

IMPORTANT: Please carefully read the Dispute Resolution Process that appears in this document after the Limited Warranty. The Dispute Resolution Process includes class-action and jury trial waivers that affect your legal rights. To opt out of these waivers, you must visit our website at www.renewalbyandersen.com/optout and complete the opt-out form within one year from the original installation date of your Renewal by Andersen® products. The opt-out only applies to the terms of the Dispute Resolution Process.

ACCLAIM
REPLACEMENT WINDOWS
EXCLUSIVELY FROM RENEWAL by ANDERSEN

Transferable Limited Warranty on Glass

The glass in Renewal by Andersen® Acclaim™ factory glazed replacement windows including High-Performance Low-E4® glass, High-Performance Low-E4® Sun glass, High-Performance Low-E4® SmartSun™ glass, High-Performance HeatLock® glass, High-Performance Low-E4 PassiveSun® glass patterned glass (including obscure, fern, reed, and cascade designs), Finelight™ grilles, divided light grilles, and tempered versions of these glass options, is warranted to be free from defects in manufacturing, materials, and workmanship for a period of twenty (20) years from the original installation date. It is also warranted not to develop, under normal conditions, any material obstruction of vision or broken glass resulting from manufacturing defects or as a result of premature failure of the glass or organic seal for a period of twenty (20) years from the original installation date. This limited warranty on glass does not apply to special order glazings, discontinued glass, art glass, insulated art glass, impact-resistant glass, or glass that is not factory installed by Renewal by Andersen.

In the event a glass failure occurs as a result of a defect in manufacturing, materials, or workmanship within the limited warranty period, Renewal by Andersen, at its option, will: (1) provide and install the appropriate replacement glass product or (2) provide a factory-authorized repair to the existing glass. Such replacement or repair is warranted for the remainder of the original limited warranty period.

Transferable Limited Warranty on Fibrex® Material Components

The Fibrex® material components of your Renewal by Andersen Acclaim replacement windows (including frame, sash, and exterior grilles) are warranted not to flake, rust, blister, peel, crack, pit, or corrode and to be free from defects in manufacturing, materials, and workmanship for a period of twenty (20) years from the original installation date.

In the event a Fibrex material component fails as a result of a defect in manufacturing, materials or workmanship within the limited warranty period, Renewal by Andersen, at its option, will: (1) provide and install the appropriate replacement components or (2) provide a factory-authorized repair to the existing product. Such replacement or repair is warranted for the remainder of the original limited warranty period.

Transferable Limited Warranty on Components Other Than Glass and Fibrex® Material

The non-glass components of your Renewal by Andersen Acclaim replacement windows, including non-electric operators, locks, lifts, balance systems, hinges, handles, insect screens, weatherstripping, sash, and frame members, are warranted to be free from defects in manufacturing, materials, and workmanship for a period of ten (10) years from the original installation date.

In the event a component other than glass or Fibrex material fails as a result of a defect in manufacturing, materials, or workmanship within the limited warranty period, Renewal by Andersen, at its option, will: (1) provide and install the appropriate replacement parts or (2) provide a factory-authorized repair to the existing product. Such replacement or repair is warranted for the remainder of the original limited warranty period.

Transferable Limited Warranty on Exterior Color Finish

The color finish on Fibrex® material exterior components (frame, sash, window sills, and grilles) on Renewal by Andersen Acclaim replacement windows is warranted to be free from manufacturing defects resulting in color fade greater than 5 delta-E* (Hunter) when measured in accordance with ASTM D2244-16el, for a period of ten (10) years from the original installation date.

Weatherstripping, accessories, and hardware, including insect screen frames, handles, trim sets, and lock components, exterior trim profiles, and exterior aluminum coil stock are not covered by this exterior color finish warranty.

In the event there is a defect covered by this limited warranty for exterior color finish within the limited warranty period, Renewal by Andersen, at its option, will: (1) re-finish the product – labor is included (the finish will be applied with standard commercial refinishing techniques and may not be the same finish as originally applied to the product) or (2) repair or replace the affected product or component. Such replacement parts, refinishing, or repairs are warranted for the remainder of the original limited warranty period.

Transferable Limited Warranty on Installation

Installation of your Renewal by Andersen® Acclaim replacement windows or other Andersen® window and/or door products by Renewal by Andersen is warranted for a period of five (5) years from the date of original installation. During this period, should your Renewal by Andersen window or door fail to perform according to our specifications due to improper original installation, we will bring the workmanship up to our professional standards, at no cost to you. See the Andersen product warranties for additional warranty details.

This limited warranty on installation does not extend to labor/services performed by anyone other than the original Renewal by Andersen installer or other contractor authorized by Renewal by Andersen nor to the installation or repair of any finishing or other materials that have been applied to or adjacent to the product after the initial installation.



Non Renewal by Andersen Products

For products that are not specifically branded Renewal by Andersen, see the specific product warranties for those Andersen products available at andersenwindows.com.

No Other Warranties or Representations

THIS LIMITED WARRANTY IS IN LIEU OF ALL OTHER WARRANTIES, EXPRESS OR IMPLIED, INCLUDING, BUT NOT LIMITED TO, ANY IMPLIED WARRANTIES OF MERCHANTABILITY OR FITNESS FOR A PARTICULAR PURPOSE. ALL WARRANTIES ARE LIMITED TO THE APPLICABLE STATUTE OF LIMITATIONS, BUT IN NO CASE WILL EXTEND BEYOND THE LIMITED WARRANTY PERIODS SPECIFIED ABOVE. RENEWAL BY ANDERSEN EXCLUDES AND WILL NOT BE LIABLE FOR ANY INCIDENTAL OR CONSEQUENTIAL DAMAGES, WHETHER ARISING OUT OF CONTRACT, TORT, OR OTHERWISE. THE REMEDY OF REPAIR OR REPLACEMENT OF THE PRODUCT PROVIDED BY THIS LIMITED WARRANTY IS THE EXCLUSIVE REMEDY WITH RESPECT TO ANY AND ALL LOSS OR DAMAGE.

Applicable Law

This Limited Warranty is only applicable in the U.S.A. (i.e., the fifty states and the District of Columbia) and Canada. This Limited Warranty gives you specific legal rights, and you may have other rights which vary from state to state or province. Some states do not allow the exclusion or limitation of incidental or consequential damages or limitation of the duration of an implied warranty, so the above limitations or exclusions may not apply to you. If any specific term of this Limited Warranty is prohibited by any applicable law, it shall be null and void, but the remainder of this Limited Warranty shall remain in full force and effect.

Non-Warranty Repair or Replacement

You will be responsible for all costs related to any repair or replacement that is not covered by this Limited Warranty or which is outside of the limited warranty period. When warranty coverage is unclear, Renewal by Andersen may charge an inspection fee for any on-site product inspection. If the service provider determines the Renewal by Andersen product has a defect covered by this Limited Warranty, the inspection fee will be waived.

*Technical measurement of color fade

What Is Not Covered by This Limited Warranty

Specific Additional Exclusions

In addition to any other limitations or exclusions in this Limited Warranty, Renewal by Andersen shall have no obligation for product failure, damage, or costs due to or related to the following:

- Product modifications or glass shading devices (e.g., glass tinting, security systems, painting or staining, insulated coverings, etc.)
- Failure due to the application of non Renewal by Andersen hardware (e.g., locksets, trim sets, hinges, panic hardware, closers, etc.)
- Water infiltration other than as a result of a defect in manufacturing, materials, or workmanship
- Failure as a result of settling or structural failure of the structure in which the products are installed
- Condensation
- Improper maintenance, such as use of brick wash, razor blades, sealants, sanding, or improper washing
- Failure to properly seal and maintain the exposed wood portions and veneer of a product in accordance with Renewal by Andersen painting or staining guidelines
- Obtaining safe and reasonable access to the product for service
- Fading of furniture, flooring, window coverings, or other surrounding materials
- Chemicals or airborne pollutants, such as salt or acid rain
- Accidents
- Acts of God
- Normal wear and tear

Additional Items Excluded from This Limited Warranty:

- Products not manufactured by Renewal by Andersen
- Products not purchased through Renewal by Andersen and installed by an authorized Renewal by Andersen installer
- Installation services other than by authorized Renewal by Andersen installers
- Removal of Renewal by Andersen Acclaim replacement windows from the structure in which it was originally installed by anyone other than an authorized Renewal by Andersen installer
- Labor, service, and materials to paint or stain any repaired or replaced product, component, trim, finish, or other materials applied to or adjacent to products or other carpentry work that may be required
- The performance of the low-maintenance exterior glass coating on products with High-Performance Low-E4® glass (performance will vary depending on environmental conditions)
- Slight glass curvature, minor scratches, or other imperfections in the glass that do not impair structural integrity or significantly obscure normal vision
- Rattling of grille bars within an air space
- Insects passing through or around the insect screen
- Tarnish or corrosion to hardware finishes
- Special glazings – contact us concerning the limited warranty on special glazings
- Broken glass
- Art glass and decorative insulated art glass, impact-resistant glass
- Fading of furniture, flooring, window coverings, or other surrounding materials
- Other product series: Some products, product options, and accessories have their own limited warranties and are not covered by this Limited Warranty. For information on warranty coverage, please refer to the specific limited warranties for these products available at andersenwindows.com

Warranty Claim Procedure

To make a claim under this Limited Warranty, contact the nearest Renewal by Andersen location, our Warranty Service Line at 800-441-1109, or visit our website at renewalbyandersen.com. We will contact you to investigate your claim within approximately two weeks after notification and arrange for appropriate action. Warranty services may be provided by Renewal by Andersen and/or an authorized Renewal by Andersen service provider.

You can help us serve you faster by providing the following important information:

- The serial number of the affected product (located on a label affixed to the top or side of the window frame)
- Description of the product concerns
- Documentation of the purchase date, if available
- Your name, address (with zip code) where product is installed, and telephone numbers

Dispute Resolution Process

General

If you are dissatisfied with the remedy provided to you under the Limited Warranty set forth above or have any other claim against Renewal by Andersen related to your Renewal by Andersen® products, you and Renewal by Andersen agree to resolve the claim using the following process ("Dispute Resolution Process"). This Dispute Resolution Process will apply to claims of any nature relating to your Renewal by Andersen product ("Dispute(s)"). Disputes include, but are not limited to: claims for breach of contract or breach of warranty; claims for violation of state or federal laws or regulations; claims based in tort, negligence, or product liability; claims based in fraud or fraud in the inducement, marketing, or advertising claims; and claims related to the enforceability or effect of any term of the Limited Warranty or the Dispute Resolution Process, including, but not limited to, the waivers of class action and jury trials.

Notice Required

To assert a Dispute, you must first provide Renewal by Andersen with written notice. A Notice of Dispute form is available for your use on Renewal by Andersen's website at www.renewalbyandersen.com/noticeofdispute.

Renewal by Andersen Response

Renewal by Andersen will have 60 days from receipt of your Notice of Dispute to respond to you in writing. In that response or at any later time, Andersen may make one or more written offers to you to resolve your Dispute.

No Class-Action or Jury Trials

YOU AGREE THAT YOU MAY ASSERT DISPUTES AGAINST RENEWAL BY ANDERSEN ONLY ON AN INDIVIDUAL BASIS AND NOT AS A PLAINTIFF OR CLASS MEMBER IN ANY CLASS OR REPRESENTATIVE ACTION OR PROCEEDING. AS PART OF THIS DISPUTE RESOLUTION PROCESS, YOU AND ANDERSEN ALSO AGREE TO WAIVE ANY RIGHT TO A JURY AND AGREE TO HAVE ALL DISPUTES HEARD AND DECIDED SOLELY BY THE FEDERAL OR STATE COURT JUDGE.

Opt-Out Procedure

You may opt out of this Dispute Resolution Process by completing and submitting a written Opt-Out Notice. The Opt-Out Notice is located on Renewal by Andersen's website at www.renewalbyandersen.com/optout. Whether or not you opt out of the Dispute Resolution Process, all terms of the Limited Warranty set forth above remain in force and effect.

Applicable Law and Severability

This Dispute Resolution Process, including, but not limited to, issues related to its enforceability and effect, will be governed by the laws of the State of Minnesota without regard to conflict of law principles. If any term of this Dispute Resolution Process is found to be invalid or unenforceable in any particular jurisdiction, that term will not apply to that issue in that jurisdiction. Instead, that term will be severed with the remaining terms continuing in full force and effect.

Questions

If you have questions about the Dispute Resolution Process or Opt-Out Procedure, contact us at 1-800-441-1109.



RENEWAL
by ANDERSEN
FULL-SERVICE WINDOW & DOOR REPLACEMENT

CLEAR OPENING AND CLEAR GLASS DIMENSIONS, cont.

DOUBLE-HUNG WINDOW

FLAT SILL INSERT

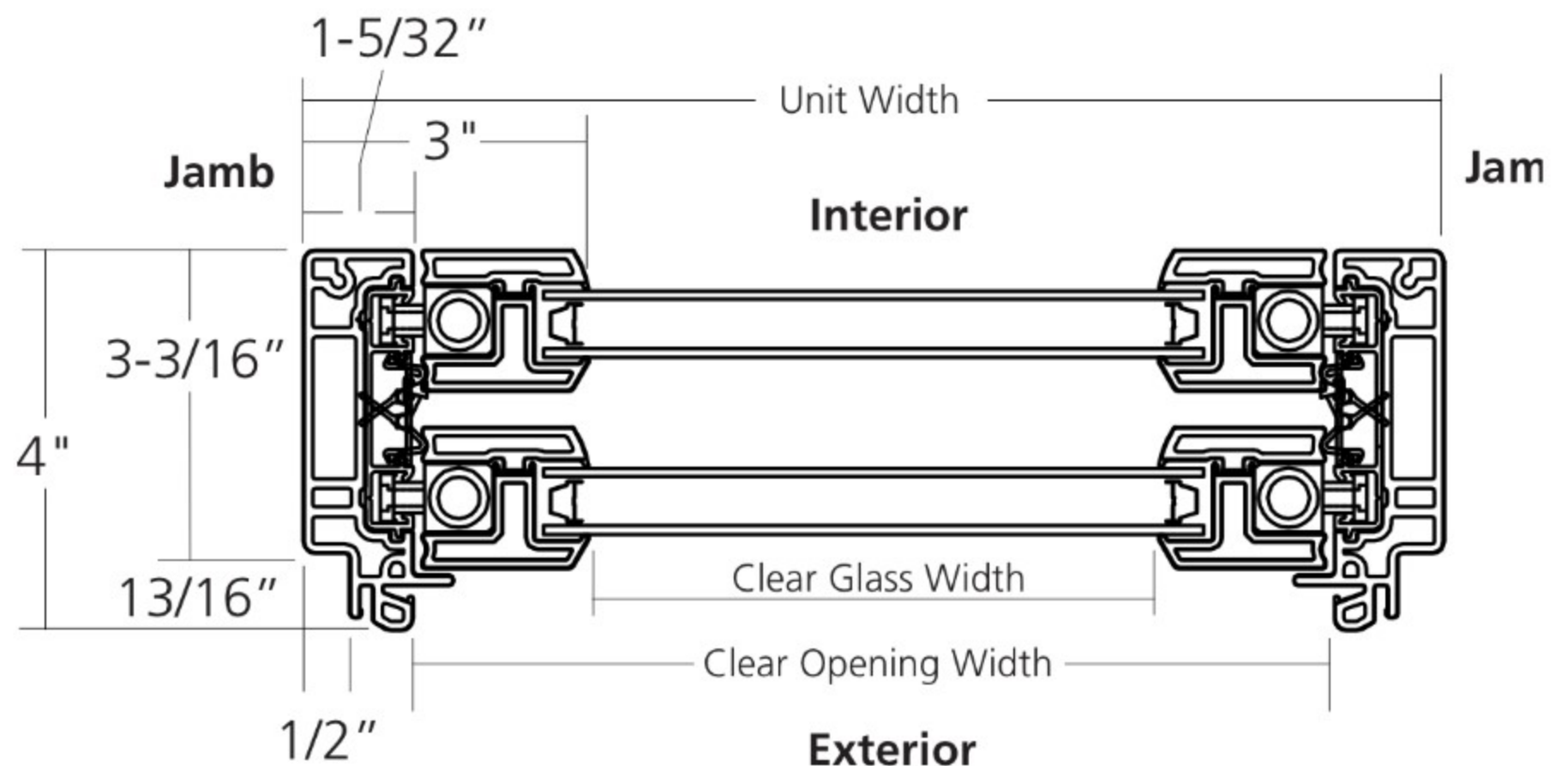
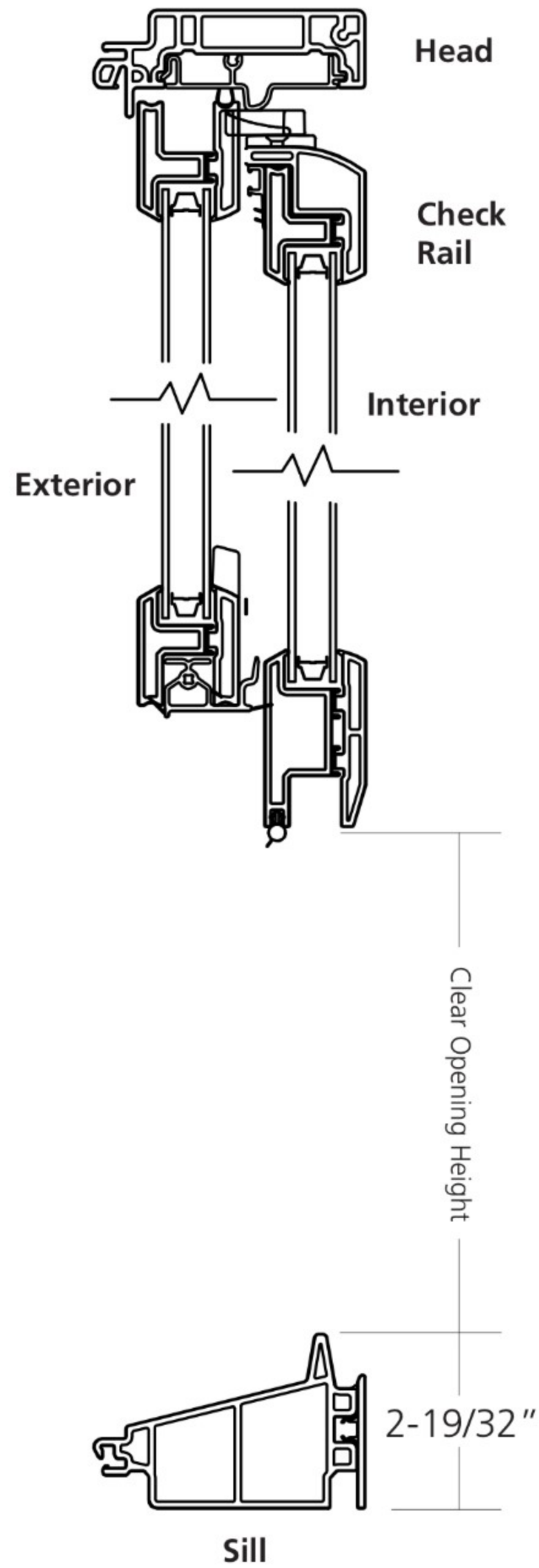
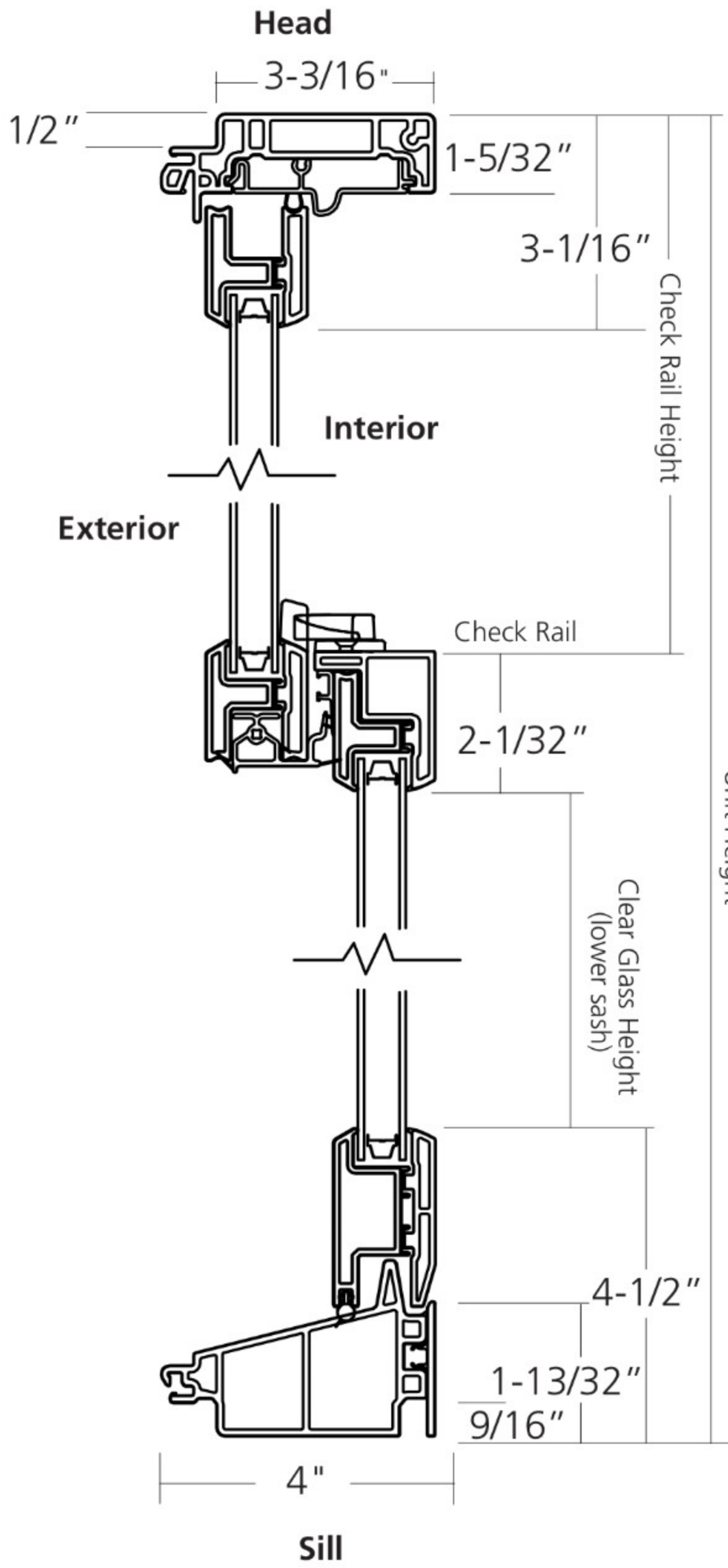

Window profiles shown for measurement purposes.

PERMA-SHIELD[®] GLIDING PATIO DOORS

200 Series
Perma-Shield[®] Gliding
Patio Doors

SECTION REFERENCE

Table of Sizes.....	34
Custom Sizes	34
Specifications	35
Grille Patterns	35
Door Details	35-36
Joining Details	36
Combination Designs	51
Performance Data.....	56

CUSTOM SIZING

in 1/8" (3) increments



Dimensions in parentheses are in millimeters.



PERMA-SHIELD® GLIDING PATIO DOORS

FEATURES

Frame

A The sill has an anodized aluminum track with a stainless steel cap that resists stains, rust and denting.* A thermal barrier reduces conductive heat loss and limits condensation on the inside.

B All basic exterior frame members are covered with a rigid vinyl which maintains an attractive appearance while minimizing maintenance.

C Wood frame members are treated with a water-repellent preservative for long-lasting** protection and performance.

Factory-assembled two-panel doors are available and arrive at the jobsite ready to install. Unassembled doors are also available and require jobsite assembly.

D A flexible vinyl weatherstrip on the head and side jambs provides a positive seal between the frame and panels.

Panel

E All panel surfaces are covered with a rigid vinyl which maintains an attractive appearance while minimizing maintenance.

F Laminated veneer lumber panels provide excellent structural stability and energy efficiency.

Dual-rollers on door panels provide smooth gliding operation with self-contained leveling adjusters.

Flexible Seal

A full-length combination weatherstrip/interlock system provides a flexible seal at the meeting stile.

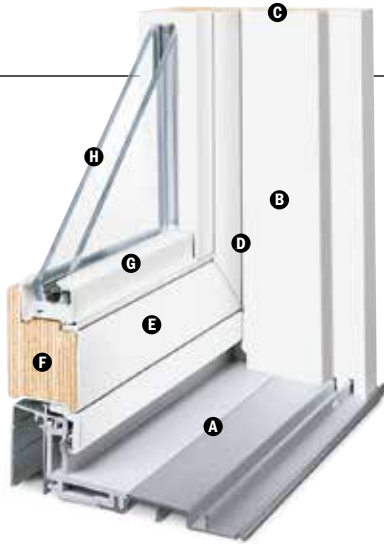

Glass

G A high-performing thermoplastic glazing bead features a flexible lip which provides superior weathertightness and long-term durability.

H Glass options include:

- Low-E tempered glass
- Low-E HeatLock® tempered glass
- Low-E Sun tempered glass
- Low-E SmartSun™ tempered glass
- Low-E SmartSun HeatLock tempered glass
- Dual-pane tempered glass

Additional glass options are available. Contact your Andersen supplier.

A removable translucent film helps shield the glass from damage during delivery and construction and simplifies finishing at the jobsite.

Blinds-Between-the-Glass



Blinds-between-the-glass are available for select gliding patio door sizes when ordered with Low-E tempered glass. White ½" (13) aluminum slat blinds come mounted between two panes of insulated glass in a dust-free environment. Blinds are magnetically controlled and can be tilted or raised and lowered using low profile controls. Smooth, simple operation allows for customized light and privacy control. Available in 33611, 5068, 51168 and 61611 door sizes. For more information, contact your Andersen supplier.

EXTERIOR & INTERIOR



HARDWARE FINISHES



Distressed bronze and oil rubbed bronze are "living" finishes that will change with time and use.

GLIDING PATIO DOOR HARDWARE OPTIONS**

Bold name denotes finish shown.



YUMA®

Distressed Bronze
Distressed Nickel

ENCINO®

Distressed Bronze
Distressed Nickel

NEWBURY®

Antique Brass
Bright Brass
Brushed Chrome
Oil Rubbed Bronze
Polished Chrome
Satin Nickel

ANVERS®

Bright Brass
Oil Rubbed Bronze
Satin Nickel

COVINGTON™

Antique Brass
Bright Brass
Oil Rubbed Bronze

WHITMORE®

Antique Brass
Bright Brass
Oil Rubbed Bronze
Satin Nickel

ALBANY

Black
Gold Dust
Stone
White

TRIBECA®

Stone
White

* Visit andersenwindows.com/warranty for details.

** Hardware sold separately.

Printing limitations prevent exact replication of colors and finishes. See your Andersen supplier for actual color and finish samples.

Tribeca and Albany hardware are zinc die cast with powder-coated durable finish. Other hardware is solid forged brass. Mix-and-match interior and exterior style and finish options are available. Bright brass and satin nickel finishes feature a 10-year limited warranty.

PERMA-SHIELD® GLIDING PATIO DOORS

Perma-Shield® Gliding Patio Door Details

Scale 1 1/2" (38) = 1'-0" (305) – 1:8

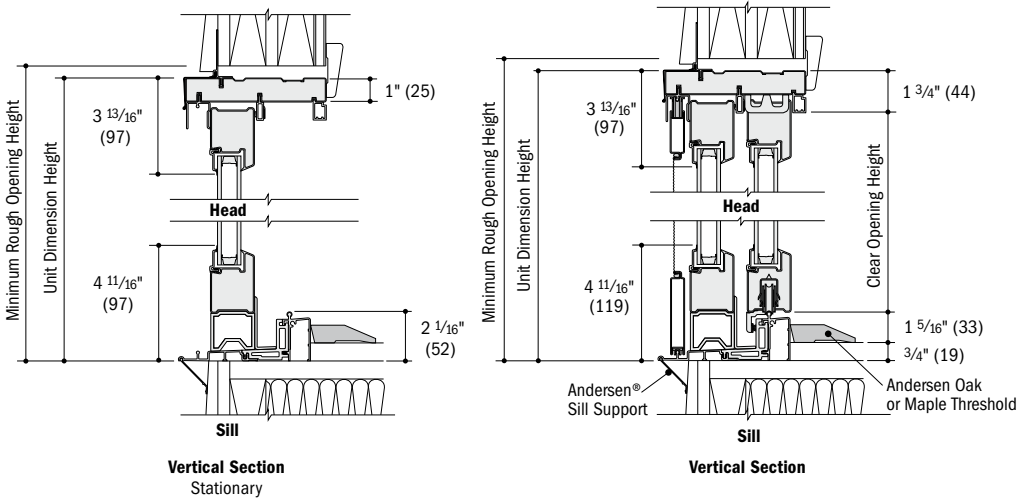

Vertical Joining Detail

Scale 1 1/2" (38) = 1'-0" (305) – 1:8

Overall Door Dimension Width

Sum of individual door widths plus 1/16" (1.5) for each join.

Overall Rough Opening Width

Overall door width plus 3/4" (19).

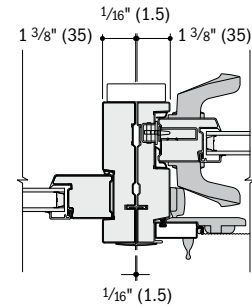

Horizontal Section

Perma-Shield® Gliding to Perma-Shield Gliding

Clear Opening Details

Scale 1 1/2" (38) = 1'-0" (305) – 1:8

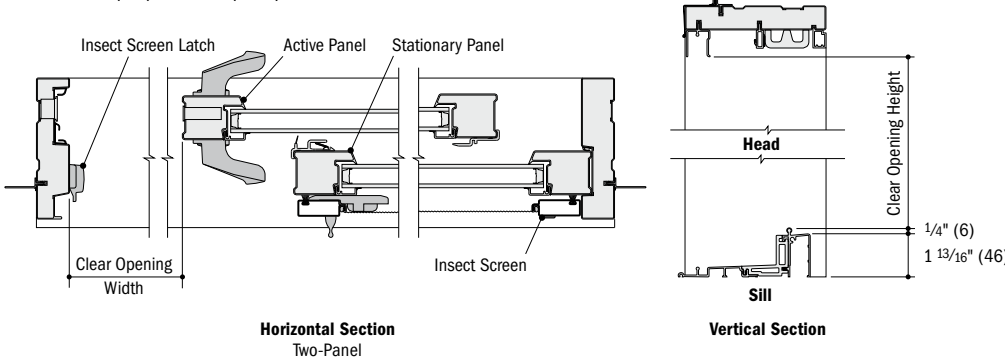

Vertical Joining Detail - LVL

Scale 1 1/2" (38) = 1'-0" (305) – 1:8

Overall Door Dimension Width

Sum of individual door widths plus 3/4" (19) for each join.

Overall Rough Opening Width

Overall door width plus 3/4" (19).

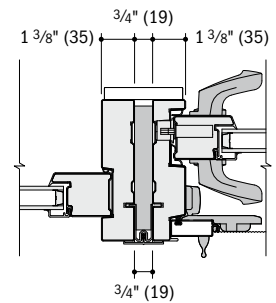

Horizontal Section

Perma-Shield® Gliding to Perma-Shield Gliding

Ramped Sill Detail

Scale 1 1/2" (38) = 1'-0" (305) – 1:8

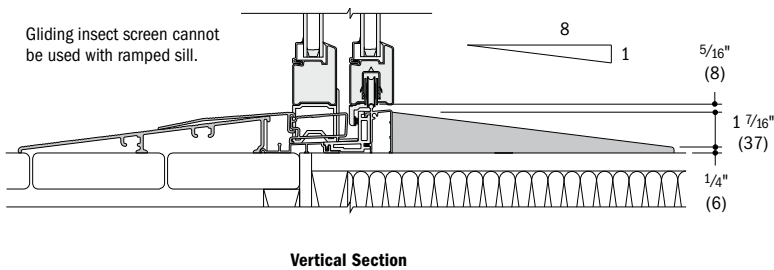

Separate Rough Openings Detail

Scale 1 1/2" (38) = 1'-0" (305) – 1:8

To meet structural requirements or to achieve a wider joined appearance, doors may be installed into separate rough openings having vertical support (by others) in combination with Andersen® exterior filler and exterior vinyl trim.

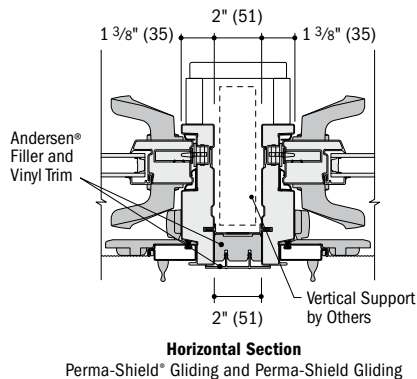

Horizontal Section

Perma-Shield® Gliding and Perma-Shield Gliding

Andersen does not recommend joining of receiver jamb to receiver jamb. For more joining information, see the combination designs section starting on page 51.

- Light-colored areas are parts included with door. Dark-colored areas are additional Andersen® parts required to complete door assembly as shown.
- Rough openings may need to be increased to allow for use of building wraps, flashing, sill panning, brackets, fasteners or other items. See installation information on pages 62-63.
- Details are for illustration only and are not intended to represent product installation methods or materials. Refer to product installation guides at andersenwindows.com.
- Andersen recommends installation of doors into separate rough openings. Consult with an architect or structural engineer regarding minimum requirements for structural support members between adjacent rough openings.
- Dimensions in parentheses are in millimeters.

What are Renewal by Andersen® windows made of?

All of our windows are made of Fibrex® material, a revolutionary composite made from reclaimed wood fiber blended with a polymer. This gives our windows the strength and durability of wood and the low-maintenance features of vinyl, while greatly limiting thermal transmittance found in other window materials such as metal.

Unlike many other window materials, Fibrex composite material won't flake, rust, blister, peel, crack, pit, or corrode.¹ It is also two times stronger than vinyl and resists warping and bowing. Never worry about scraping or painting your windows again.

Andersen
EXCLUSIVE
FEATURE

ENGINEERED WITH

FIBREX®
MATERIAL

SMART MATERIALS

Fibrex® material is twice as strong as vinyl, so weathertight seals stay weathertight.

COLOR CHOICE

Our unique process fuses color to Fibrex® material for long-lasting beauty as well as offering dark exterior colors not available on most other replacement windows.

EXCEPTIONAL COMFORT

Fibrex® material blocks thermal transfer nearly 700 times better than aluminum to help reduce heating and cooling bills.

EXCEPTIONAL DURABILITY

Fibrex® material retains its stability and rigidity in all climates.²

	Fibrex®	Aluminum	Vinyl	Wood
Insulating Properties	✓		✓	✓
Low Maintenance	✓	✓	✓	
Resistance to Decay/Corrosion	✓		✓	
Structural Rigidity	✓	✓		✓
Durability	✓	✓		✓
Color/Finish Choices	✓			✓
Maximum Glass Area	✓	✓		varies
Dark Color Performance	✓	✓		✓