



**APPLICATION FOR
HISTORIC AREA WORK PERMIT**
HISTORIC PRESERVATION COMMISSION
301.563.3400

FOR STAFF ONLY:
HAWP# _____
DATE ASSIGNED _____

APPLICANT:

Name: _____ E-mail: _____
Address: _____ City: _____ Zip: _____
Daytime Phone: _____ Tax Account No.: _____

AGENT/CONTACT (if applicable):

Name: _____ E-mail: _____
Address: _____ City: _____ Zip: _____
Daytime Phone: _____ Contractor Registration No.: _____

LOCATION OF BUILDING/PREMISE: MIHP # of Historic Property _____

Is the Property Located within an Historic District? Yes/District Name _____
 No/Individual Site Name _____

Is there an Historic Preservation/Land Trust/Environmental Easement on the Property? If YES, include a map of the easement, and documentation from the Easement Holder supporting this application.

Are other Planning and/or Hearing Examiner Approvals /Reviews Required as part of this Application? (Conditional Use, Variance, Record Plat, etc.?) If YES, include information on these reviews as supplemental information.

Building Number: _____ Street: _____

Town/City: _____ Nearest Cross Street: _____

Lot: _____ Block: _____ Subdivision: _____ Parcel: _____

TYPE OF WORK PROPOSED: See the checklist on Page 4 to verify that all supporting items for proposed work are submitted with this application. Incomplete Applications will not be accepted for review. Check all that apply:

- | | | |
|---|--|--|
| <input type="checkbox"/> New Construction | <input type="checkbox"/> Deck/Porch | <input type="checkbox"/> Shed/Garage/Accessory Structure |
| <input type="checkbox"/> Addition | <input type="checkbox"/> Fence | <input type="checkbox"/> Solar |
| <input type="checkbox"/> Demolition | <input type="checkbox"/> Hardscape/Landscape | <input type="checkbox"/> Tree removal/planting |
| <input type="checkbox"/> Grading/Excavation | <input type="checkbox"/> Roof | <input type="checkbox"/> Window/Door |
| | | <input type="checkbox"/> Other: _____ |

I hereby certify that I have the authority to make the foregoing application, that the application is correct and accurate and that the construction will comply with plans reviewed and approved by all necessary agencies and hereby acknowledge and accept this to be a condition for the issuance of this permit.

Signature of owner or authorized agent _____
Date

HAWP APPLICATION: MAILING ADDRESSES FOR NOTIFYING
[Owner, Owner's Agent, Adjacent and Confronting Property Owners]

Owner's mailing address	Owner's Agent's mailing address
Adjacent and confronting Property Owners mailing addresses	

Description of Property: Please describe the building and surrounding environment. Include information on significant structures, landscape features, or other significant features of the property:

Description of Work Proposed: Please give an overview of the work to be undertaken:

Work Item 1: _____	
Description of Current Condition:	Proposed Work:

Work Item 2: _____	
Description of Current Condition:	Proposed Work:

Work Item 3: _____	
Description of Current Condition:	Proposed Work:

**HISTORIC AREA WORK PERMIT
CHECKLIST OF
APPLICATION REQUIREMENTS**

	Required Attachments						
Proposed Work	I. Written Description	2. Site Plan	3. Plans/ Elevations	4. Material Specifications	5. Photographs	6. Tree Survey	7. Property Owner Addresses
New Construction	*	*	*	*	*	*	*
Additions/ Alterations	*	*	*	*	*	*	*
Demolition	*	*	*		*		*
Deck/Porch	*	*	*	*	*	*	*
Fence/Wall	*	*	*	*	*	*	*
Driveway/ Parking Area	*	*		*	*	*	*
Grading/Excavation/ Landscaping	*	*		*	*	*	*
Tree Removal	*	*		*	*	*	*
Siding/ Roof Changes	*	*	*	*	*		*
Window/ Door Changes	*	*	*	*	*		*
Masonry Repair/ Repoint	*	*	*	*	*		*
Signs	*	*	*	*	*		*

SCOPE OF WORK

THE SCOPE OF WORK FOR THIS PROJECT CONSISTS OF:

- EXCAVATION AND INSTALLATION OF FIBERGLASS SWIMMING POOL.
- CONSTRUCTION OF POOL DECKING

PROPERTY INFO

LOT-BLOCK=54, PART OF LOTS 65 & 66 – BLOCK 13

ZONE= R-60

SUBDIVISION: KENSINGTON

HISTORIC MASTER: Y

HISTORIC ATLAS: N

DRAWING LIST

1. VICINITY PLAN
2. SITE LAYOUT
3. SAN JUAN – RESIDENTIAL POOLS
4. SPECIFICATIONS DETAILS POOL
5. DIG PLAN
6. POOL DETAILS PAGE 1
7. POOL DETAILS PAGE 2
8. WHITE GOODS PLACEMENT
9. HARDSCAPE LAYOUT
10. PHOTOGRAPHS PAGE 1
11. PHOTOGRAPHS PAGE 2
12. PHOTOGRAPHS PAGE 3
13. PHOTOGRAPHS PAGE 4

VICINITY MAP

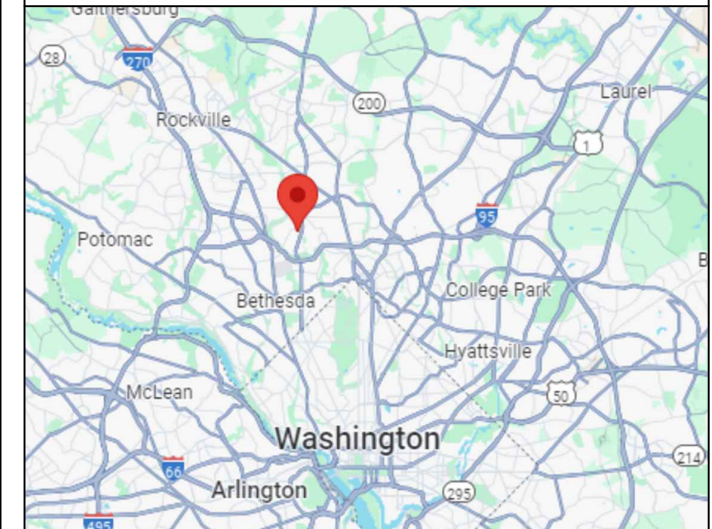

POOL DATA

DIMENSIONS	29'-1" X 15'-0" RECTANGLE FIBERGLASS POOL
PERIMETER	88 LF
SURFACE AREA	436 SQ.FT.
GALLONAGE	10,789 GALLONS
DEPTHS	3'-4" TO 6'-2"
FILTER RATE	30 GPM
TURNOVER TIME	6 HOURS
POOL DECK AREA	510 SQ.FT.

PROJECT NAME

CUSTOMER	MARCELO CABROL & CAROLA ALVAREZ
ADDRESS	3940 WASHINGTON STREET KENSINGTON, MD, 20895
PHONE 1	202-256-1304
PHONE 2	carolaa2018@gmail.com
EMAIL	-
COUNTY	13TH ELECTION DISTRICT, MONTGOMERY COUNTY
SUBDIVISION	KENSINGTON PARK
LOT DATA	LOT 54 & PARTS OF LOT 65 & 66, BLOCK 13
TAX ID#	13-01020550

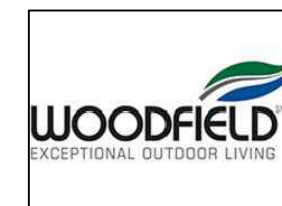

WOODFIELD OUTDOORS
 2112 Belair Road, Ste 3
 Fallston, Maryland 21047
 Phone: (443) 299-6500
 MHIC: 121071

VICINITY PLAN V1

VP

VICINITY PLAN

Montgomery County Zoning

Date: 1/7/2025

Montgomery County
Planning Department
ITI Division

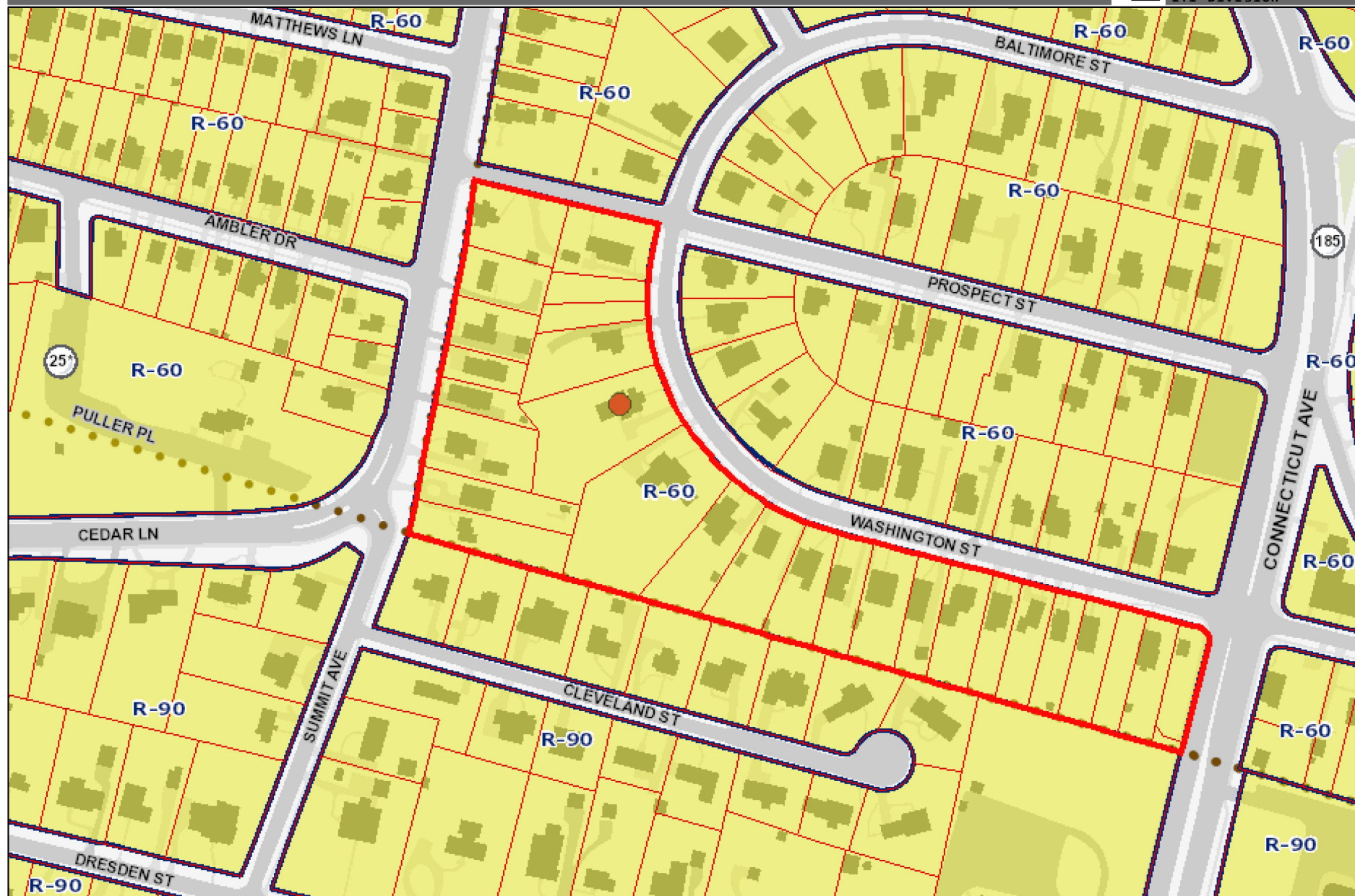

Account #	01020550
Address	3940 WASHINGTON ST KENSINGTON, 20895
Zone	R-60
Overlay Zone	N/A
TDR Overlay Zone	N/A
Landuse	Single Family Detached
Parcel, Lot, Block	N/A, 54, 13
WSSC Grid	213NW04
Map Amendments	N/A

Parking District	N/A
CBD	N/A
Special Protection Area	N/A
Urban District	N/A
Enterprise Zone	N/A
Arts & Ent. District	N/A
Special Tax District	N/A
Legal Description	PT LTS 65-66 KENSINGTON PARK

Bike/Ped Priority Area	Kensington
Urban Renewal Area	N/A
Metro Station Policy Area	N/A
Priority Funding Area	Yes
Septic Tier	Tier 1: Sewer existing
Municipality	KENSINGTON
Master Plan	KENSINGTON SECTOR PLAN 2010
Historic Site/District	KENSINGTON HISTORIC DISTRICT
Water/Sewer Categories	N/A

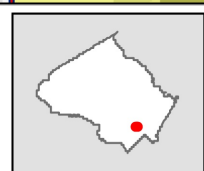

VICINITY MAP

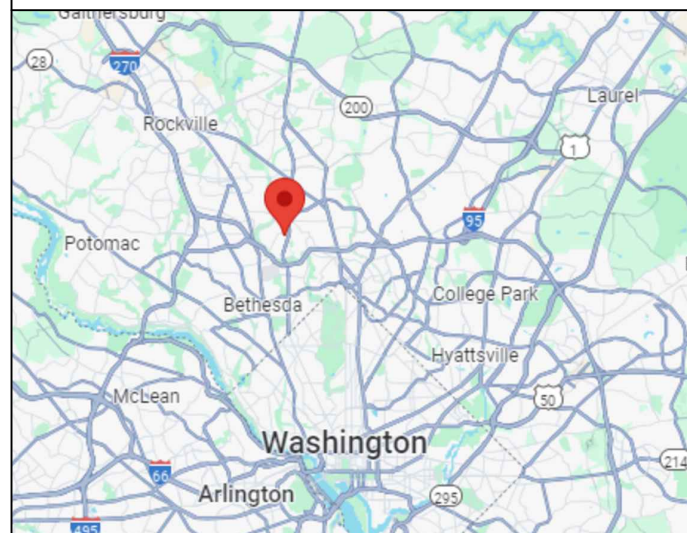

POOL DATA

DIMENSIONS	29'-1" X 15'-0" RECTANGLE FIBERGLASS POOL
PERIMETER	88 LF
SURFACE AREA	436 SQ.FT.
GALLONAGE	10,789 GALLONS
DEPTHS	3'-4" TO 6'-2"
FILTER RATE	30 GPM
TURNOVER TIME	6 HOURS
POOL DECK AREA	510 SQ.FT.

PROJECT NAME

CUSTOMER	MARCELO CABROL & CAROLA ALVAREZ
ADDRESS	3940 WASHINGTON STREET KENSINGTON, MD, 20895
PHONE 1	202-256-1304
PHONE 2	carolaa2018@gmail.com
EMAIL	-
COUNTY	13TH ELECTION DISTRICT, MONTGOMERY COUNTY
SUBDIVISION	KENSINGTON PARK
LOT DATA	LOT 54 & PARTS OF LOT 65 & 66, BLOCK 13
TAX ID#	13-01020550

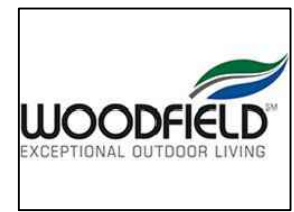

WOODFIELD OUTDOORS
2112 Belair Road, Ste 3
Fallston, Maryland 21047
Phone: (443) 299-6500
MHIC: 121071

VICINITY PLAN V1

VP

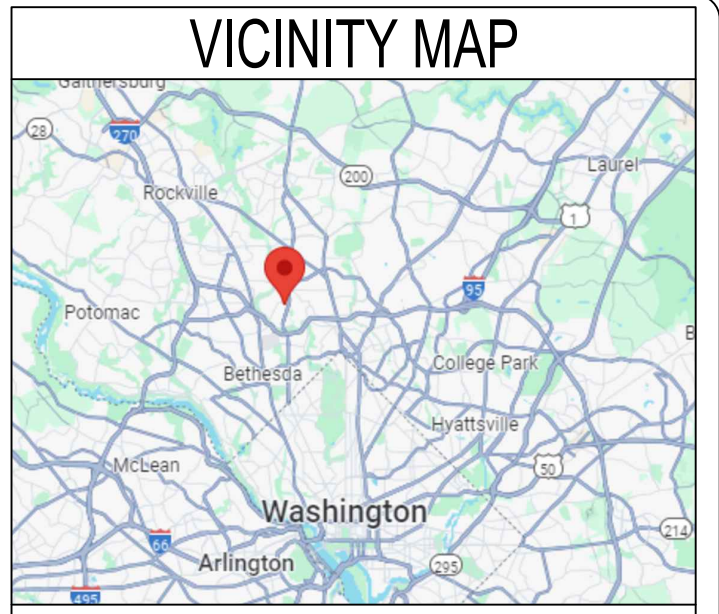
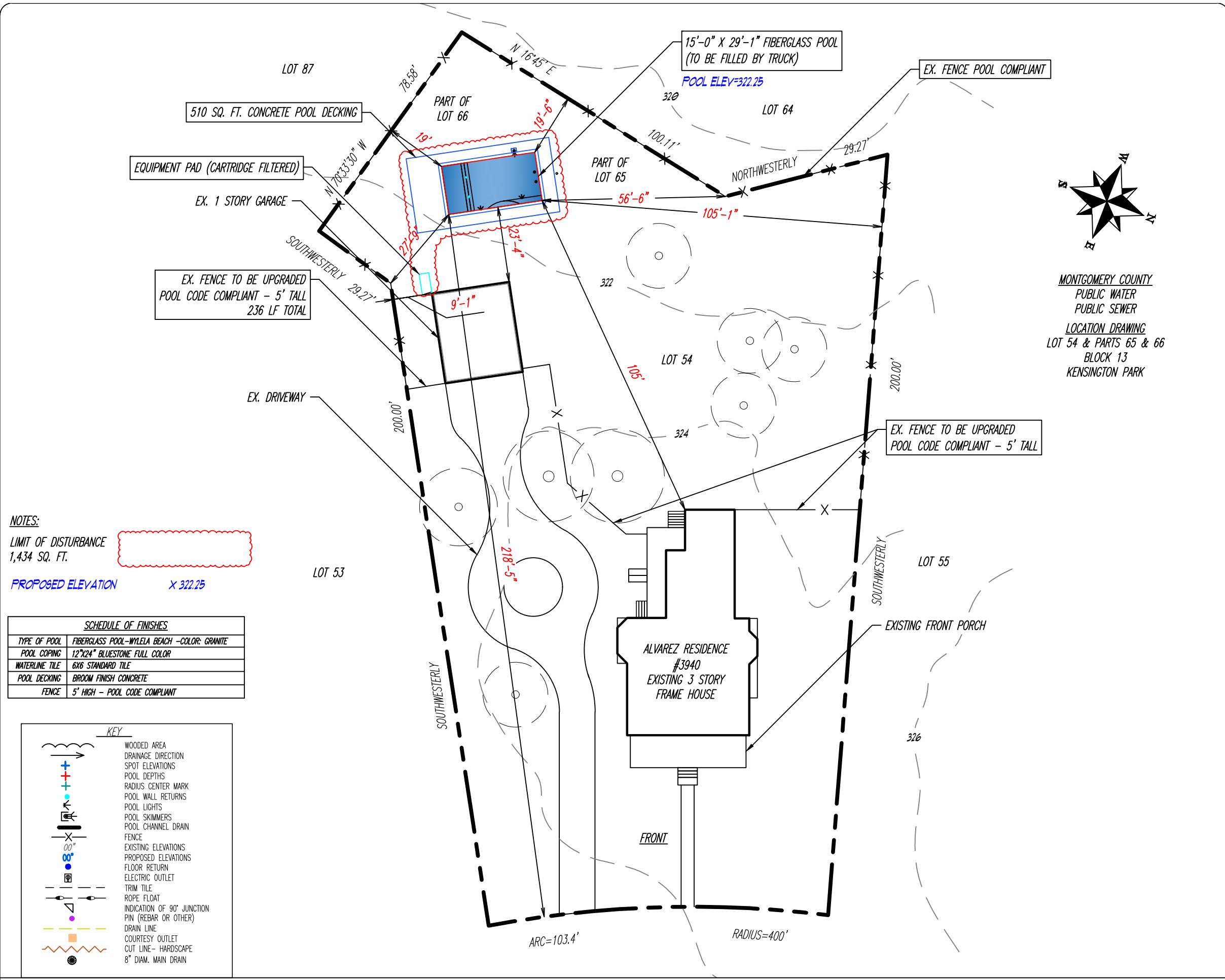

MONTGOMERY COUNTY
 PUBLIC WATER
 PUBLIC SEWER
 LOCATION DRAWING
 LOT 54 & PARTS 65 & 66
 BLOCK 13
 KENSINGTON PARK

NOTES:
 LIMIT OF DISTURBANCE
 1,434 SQ. FT.

PROPOSED ELEVATION X 322.25

SCHEDULE OF FINISHES	
TYPE OF POOL	FIBERGLASS POOL-WYLELA BEACH-COLOR: GRANITE
POOL COPING	12"x24" BLUESTONE FULL COLOR
WATERLINE TILE	6X6 STANDARD TILE
POOL DECKING	BROOM FINISH CONCRETE
FENCE	5' HIGH - POOL CODE COMPLIANT

KEY	
	WOODED AREA
	DRAINAGE DIRECTION
	SPOT ELEVATIONS
	POOL DEPTHS
	RADIUS CENTER MARK
	POOL WALL RETURNS
	POOL LIGHTS
	POOL SKIMMERS
	POOL CHANNEL DRAIN
	FENCE
	EXISTING ELEVATIONS
	PROPOSED ELEVATIONS
	FLOOR RETURN
	ELECTRIC OUTLET
	TRIM TILE
	ROPE FLOAT
	INDICATION OF 90° JUNCTION
	PIN (REBAR OR OTHER)
	DRAIN LINE
	COURTESY OUTLET
	CUT LINE - HARDSCAPE
	8" DIAM. MAIN DRAIN

POOL DATA

DIMENSIONS	29'-1" X 15'-0" RECTANGLE FIBERGLASS POOL
PERIMETER	88 LF
SURFACE AREA	436 SQ.FT.
GALLONAGE	10,789 GALLONS
DEPTHS	3'-4" TO 6'-2"
FILTER RATE	30 GPM
TURNOVER TIME	6 HOURS
POOL DECK AREA	510 SQ.FT.

PROJECT NAME

CUSTOMER	MARCELO CABROL & CAROLA ALVAREZ
ADDRESS	3940 WASHINGTON STREET KENSINGTON, MD, 20895
PHONE 1	202-256-1304
PHONE 2	carolaa2018@gmail.com
EMAIL	-
COUNTY	13TH ELECTION DISTRICT, MONTGOMERY COUNTY
SUBDIVISION	KENSINGTON PARK
LOT DATA	LOT 54 & PARTS OF LOT 65 & 66, BLOCK 13
TAX ID#	13-01020550

	WOODFIELD OUTDOORS
	2112 Belair Road, Ste 3 Fallston, Maryland 21047
	Phone: (443) 299-6500
	MHIC: 121071

SITE LAYOUT V1	SP
----------------	----

VICINITY MAP

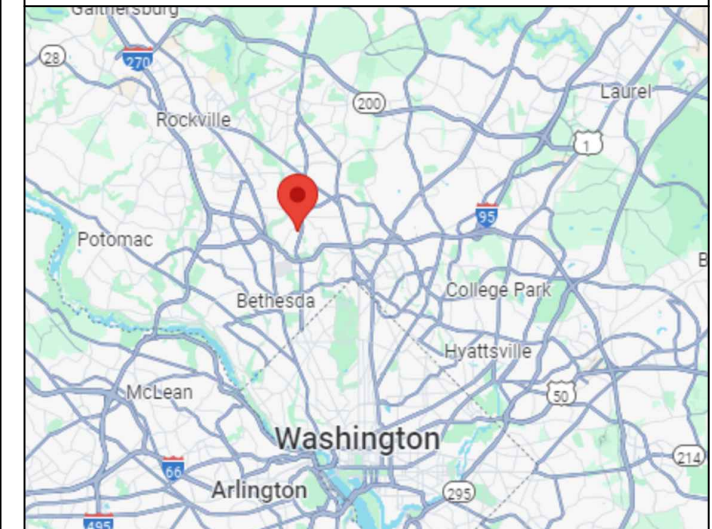

POOL DATA

DIMENSIONS	29'-1" X 15'-0" RECTANGLE FIBERGLASS POOL
PERIMETER	88 LF
SURFACE AREA	436 SQ.FT.
GALLONAGE	10,789 GALLONS
DEPTHS	3'-4" TO 6'-2"
FILTER RATE	30 GPM
TURNOVER TIME	6 HOURS
POOL DECK AREA	510 SQ.FT.

PROJECT NAME

CUSTOMER	MARCELO CABROL & CAROLA ALVAREZ
ADDRESS	3940 WASHINGTON STREET KENSINGTON, MD, 20895
PHONE 1	202-256-1304
PHONE 2	carolaa2018@gmail.com
EMAIL	-
COUNTY	13TH ELECTION DISTRICT, MONTGOMERY COUNTY
SUBDIVISION	KENSINGTON PARK
LOT DATA	LOT 54 & PARTS OF LOT 65 & 66, BLOCK 13
TAX ID#	13-01020550

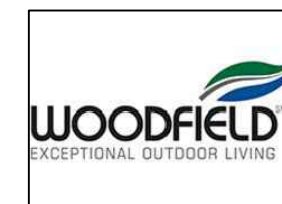

WOODFIELD OUTDOORS
 2112 Belair Road, Ste 3
 Fallston, Maryland 21047
 Phone: (443) 299-6500
 MHIC: 121071

DIG PLAN V1

DP

DIG PLAN

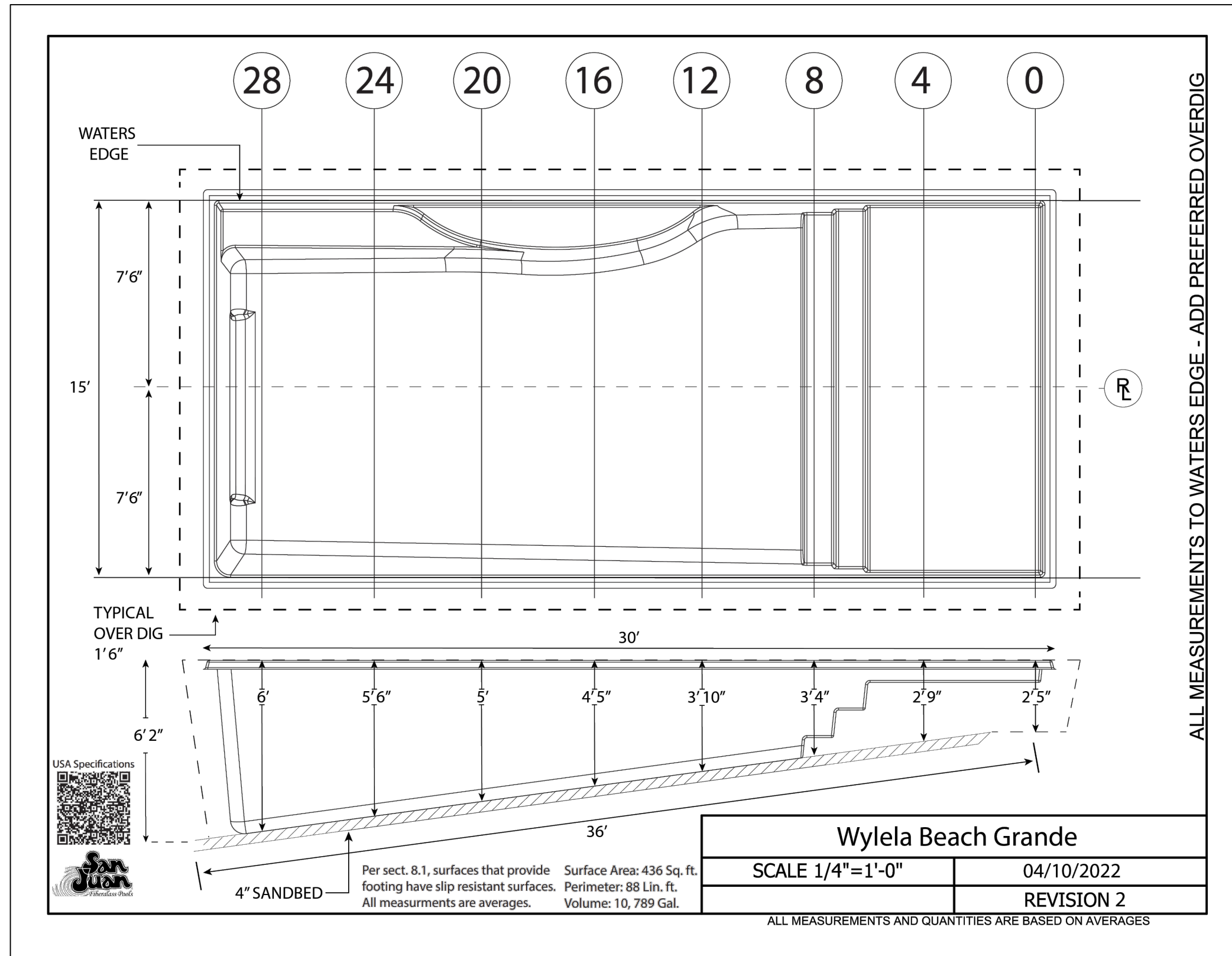

ALL MEASUREMENTS TO WATERS EDGE - ADD PREFERRED OVERDIG

Wylela Beach Grande	
SCALE 1/4"=1'-0"	04/10/2022
REVISION 2	

ALL MEASUREMENTS AND QUANTITIES ARE BASED ON AVERAGES



Per sect. 8.1, surfaces that provide footing have slip resistant surfaces. All measurements are averages.
 Surface Area: 436 Sq. ft.
 Perimeter: 88 Lin. ft.
 Volume: 10,789 Gal.

WYLELA BEACH GRANDE DETAIL SHEET - 11-16-22 - REVISION

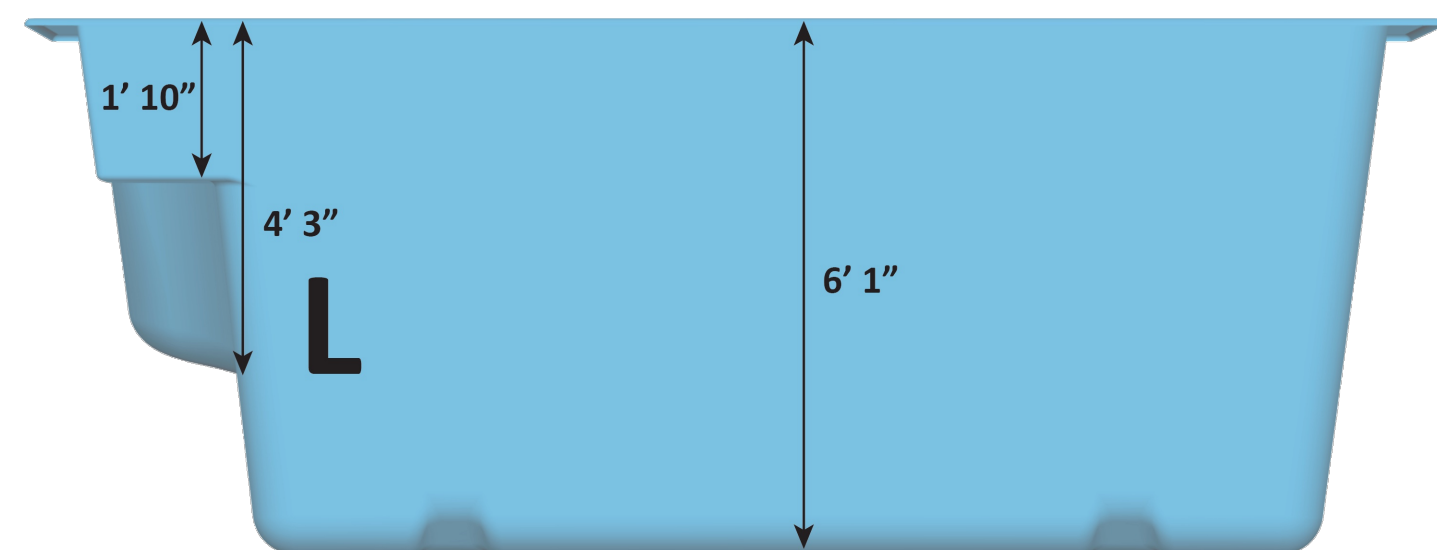
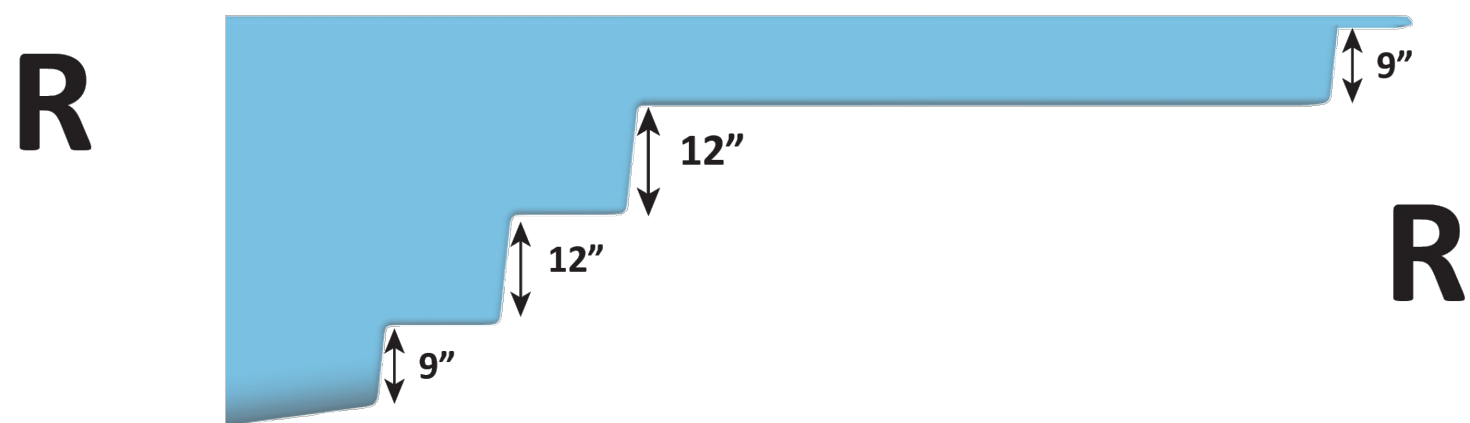
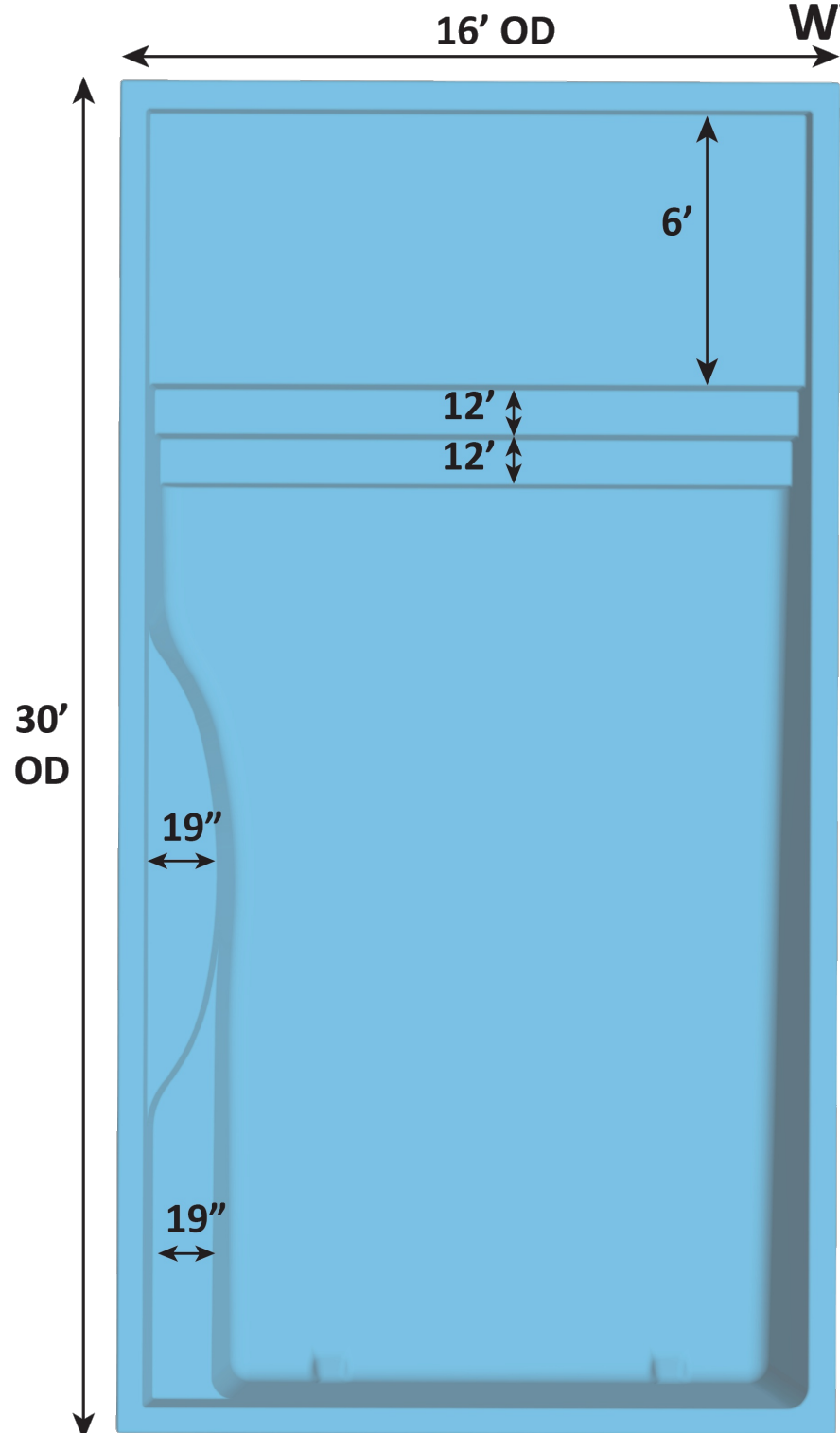

Surface Area: 436 Sq. ft.
 Perimeter: 88 Lin. ft.
 Volume: 10, 789 Gal.
 Per sect. 8.1, surfaces that provide footing have slip resistant surfaces.
 All measurments are averages.



VICINITY MAP

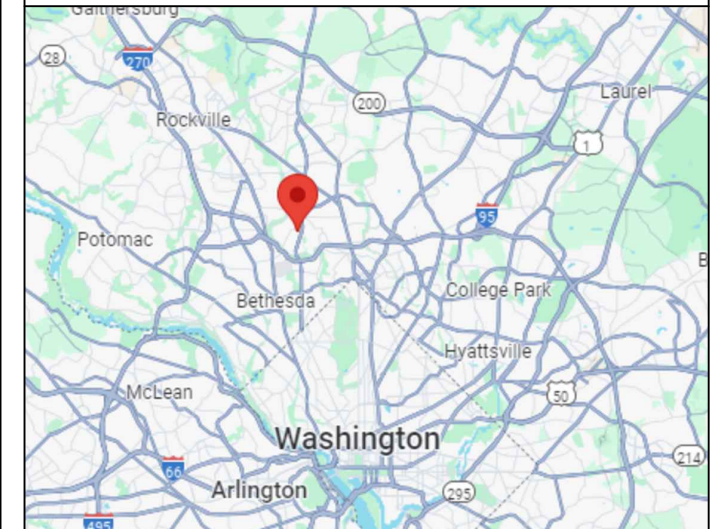

POOL DATA

DIMENSIONS	29'-1" X 15'-0" RECTANGLE FIBERGLASS POOL
PERIMETER	88 LF
SURFACE AREA	436 SQ.FT.
GALLONAGE	10,789 GALLONS
DEPTHS	3'-4" TO 6'-2"
FILTER RATE	30 GPM
TURNOVER TIME	6 HOURS
POOL DECK AREA	510 SQ.FT.

PROJECT NAME

CUSTOMER	MARCELO CABROL & CAROLA ALVAREZ
ADDRESS	3940 WASHINGTON STREET KENSINGTON, MD, 20895
PHONE 1	202-256-1304
PHONE 2	carolaa2018@gmail.com
EMAIL	-
COUNTY	13TH ELECTION DISTRICT, MONTGOMERY COUNTY
SUBDIVISION	KENSINGTON PARK
LOT DATA	LOT 54 & PARTS OF LOT 65 & 66, BLOCK 13
TAX ID#	13-01020550

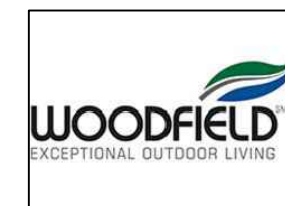

WOODFIELD OUTDOORS
 2112 Belair Road, Ste 3
 Fallston, Maryland 21047
 Phone: (443) 299-6500
 MHIC: 121071

DETAILS - PAGE 1

DP

WYLELA BEACH GRANDE DETAIL SHEET - 11-16-22 - REVISION 01

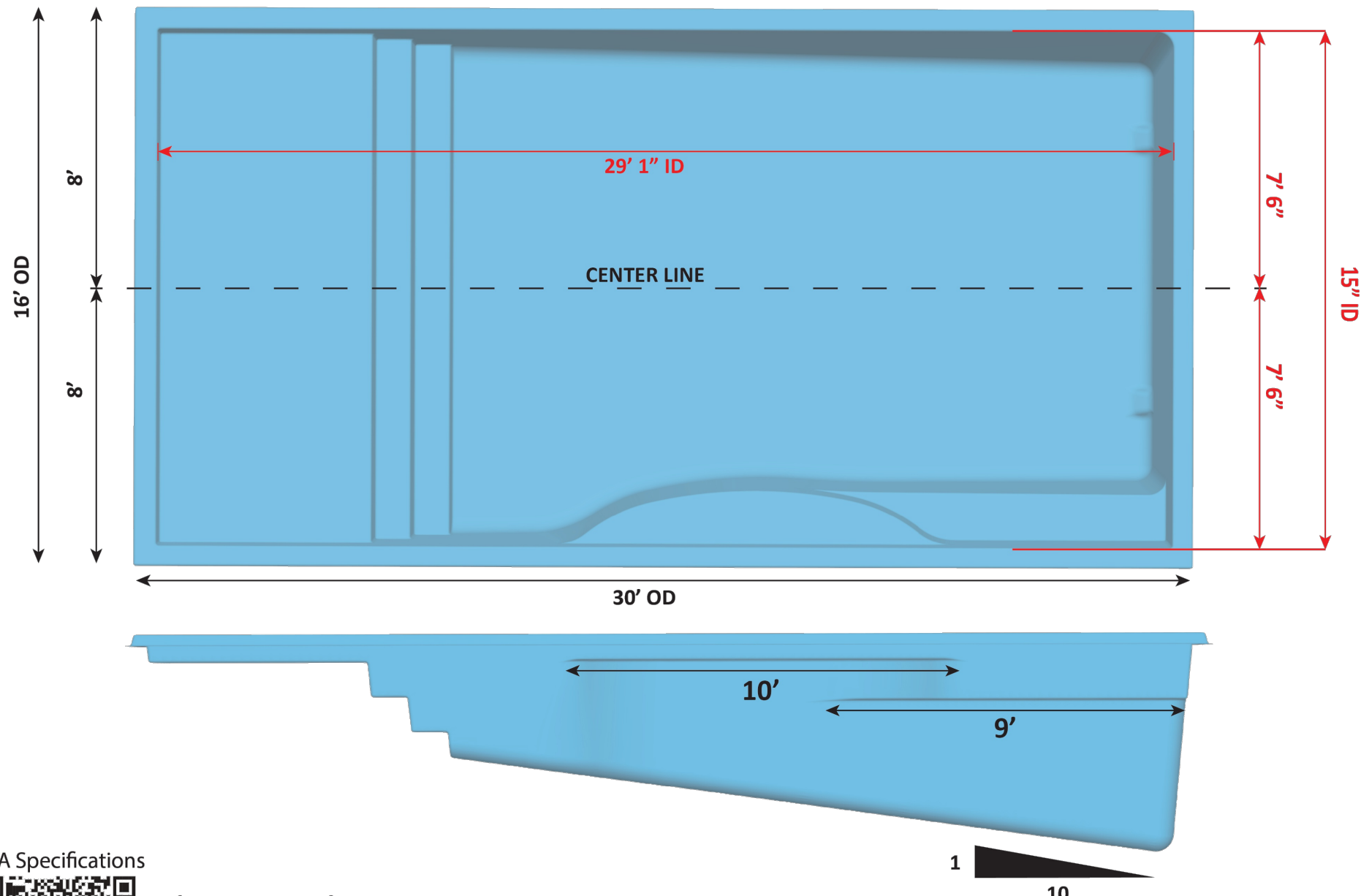

USA Specifications



Surface Area: 436 Sq. ft.
 Perimeter: 88 Lin. ft.
 Volume: 10, 789 Gal.
 Per sect. 8.1, surfaces that provide footing have slip resistant surfaces.
 All measurements are averages.



VICINITY MAP

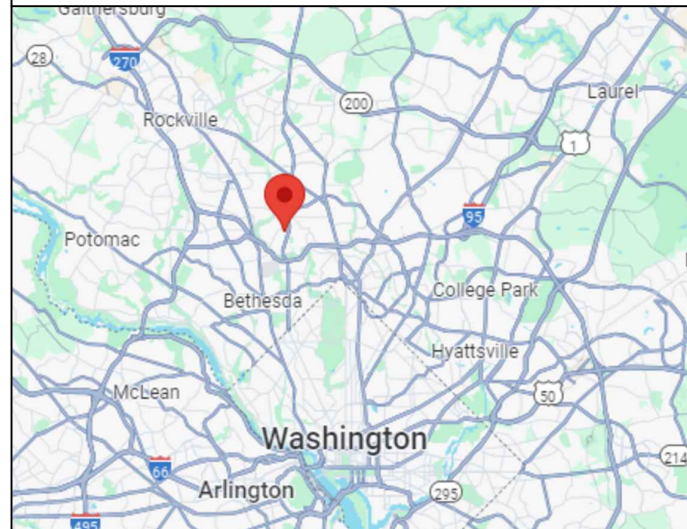

POOL DATA

DIMENSIONS	29'-1" X 15'-0" RECTANGLE FIBERGLASS POOL
PERIMETER	88 LF
SURFACE AREA	436 SQ.FT.
GALLONAGE	10,789 GALLONS
DEPTHS	3'-4" TO 6'-2"
FILTER RATE	30 GPM
TURNOVER TIME	6 HOURS
POOL DECK AREA	510 SQ.FT.

PROJECT NAME

CUSTOMER	MARCELO CABROL & CAROLA ALVAREZ
ADDRESS	3940 WASHINGTON STREET KENSINGTON, MD, 20895
PHONE 1	202-256-1304
PHONE 2	carolaa2018@gmail.com
EMAIL	-
COUNTY	13TH ELECTION DISTRICT, MONTGOMERY COUNTY
SUBDIVISION	KENSINGTON PARK
LOT DATA	LOT 54 & PARTS OF LOT 65 & 66, BLOCK 13
TAX ID#	13-01020550

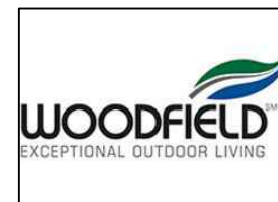

WOODFIELD OUTDOORS
 2112 Belair Road, Ste 3
 Fallston, Maryland 21047
 Phone: (443) 299-6500
 MHIC: 121071

DETAILS - PAGE 2

DP

VICINITY MAP

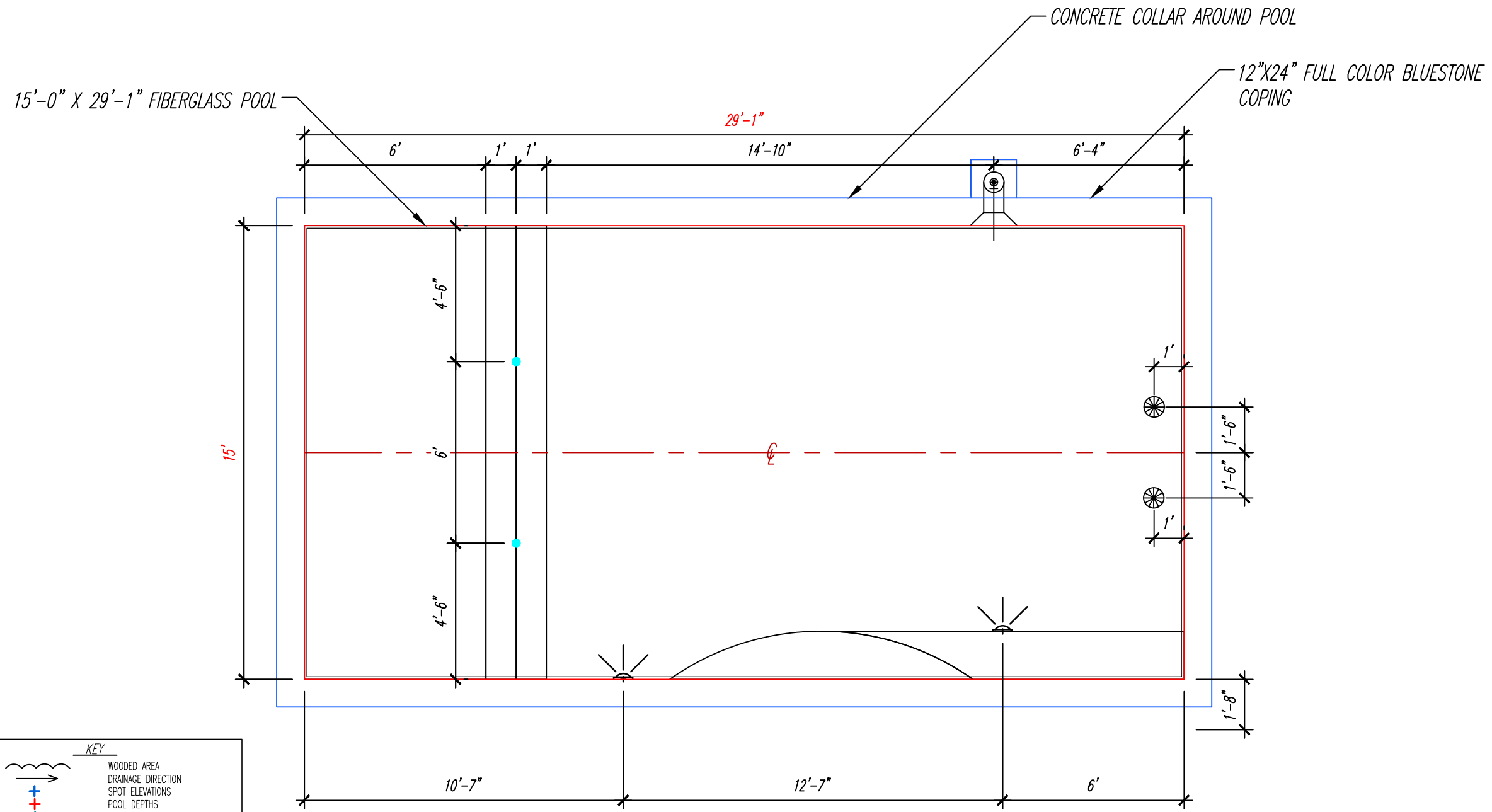
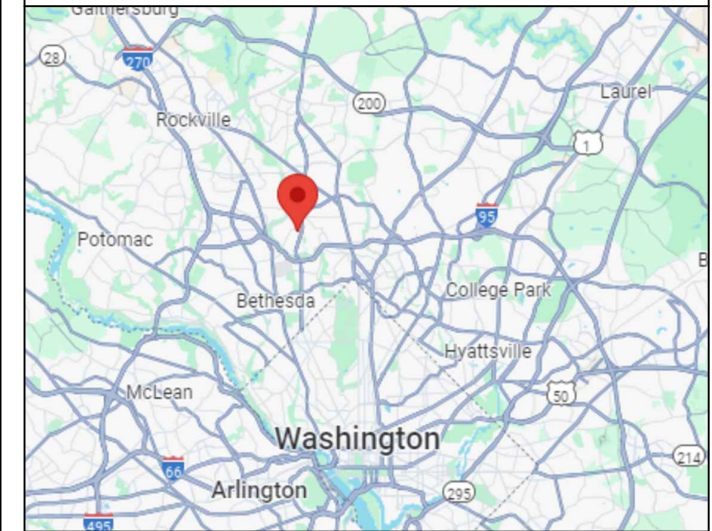

POOL DATA

DIMENSIONS	29'-1" X 15'-0" RECTANGLE FIBERGLASS POOL
PERIMETER	88 LF
SURFACE AREA	436 SQ.FT.
GALLONAGE	10,789 GALLONS
DEPTHS	3'-4" TO 6'-2"
FILTER RATE	30 GPM
TURNOVER TIME	6 HOURS
POOL DECK AREA	510 SQ.FT.

PROJECT NAME

CUSTOMER	MARCELO CABROL & CAROLA ALVAREZ
ADDRESS	3940 WASHINGTON STREET KENSINGTON, MD, 20895
PHONE 1	202-256-1304
PHONE 2	carolaa2018@gmail.com
EMAIL	-
COUNTY	13TH ELECTION DISTRICT, MONTGOMERY COUNTY
SUBDIVISION	KENSINGTON PARK
LOT DATA	LOT 54 & PARTS OF LOT 65 & 66, BLOCK 13
TAX ID#	13-01020550

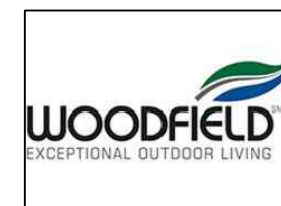

WOODFIELD OUTDOORS
 2112 Belair Road, Ste 3
 Fallston, Maryland 21047
 Phone: (443) 299-6500
 MHIC: 121071

WHITE GOODS PLACEMENT V1

WGP

WHITE GOODS PLACEMENT

SCHEDULE OF FINISHES	
TYPE OF POOL	FIBERGLASS POOL-WYLELA BEACH -COLOR: GRANITE
POOL COPING	12"X24" BLUESTONE FULL COLOR
WATERLINE TILE	6X6 STANDARD TILE
POOL DECKING	BROOM FINISH CONCRETE
FENCE	5' HIGH - POOL CODE COMPLIANT

- KEY**
- WOODED AREA
 - DRAINAGE DIRECTION
 - SPOT ELEVATIONS
 - POOL DEPTHS
 - RADIUS CENTER MARK
 - POOL WALL RETURNS
 - POOL LIGHTS
 - POOL SKIMMERS
 - POOL CHANNEL DRAIN
 - FENCE
 - EXISTING ELEVATIONS
 - PROPOSED ELEVATIONS
 - FLOOR RETURN
 - ELECTRIC OUTLET
 - TRIM TILE
 - ROPE FLOAT
 - INDICATION OF 90° JUNCTION
 - PIN (REBAR OR OTHER)
 - DRAIN LINE
 - COURTESY OUTLET
 - CUT LINE - HARDSCAPE
 - 8" DIAM. MAIN DRAIN

PERMIT PLAN - WHITE GOODS PLACEMENT V1 - 01.10.25

WGP 1/4"=1'-0"

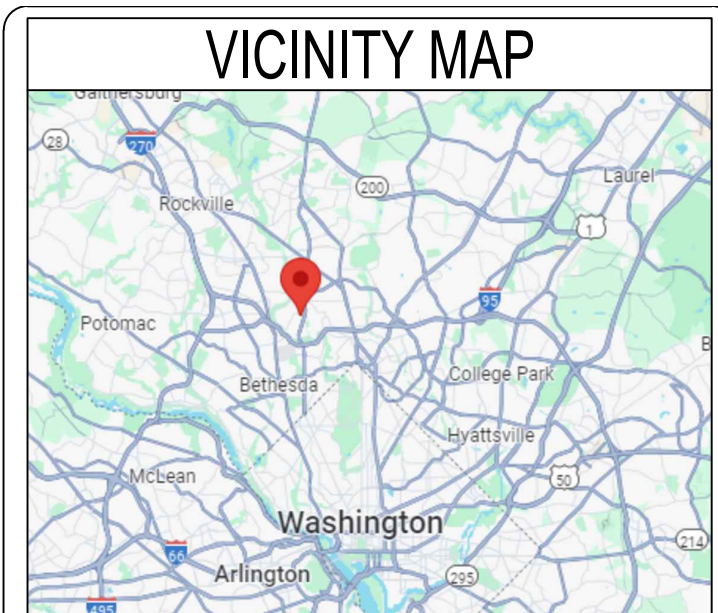
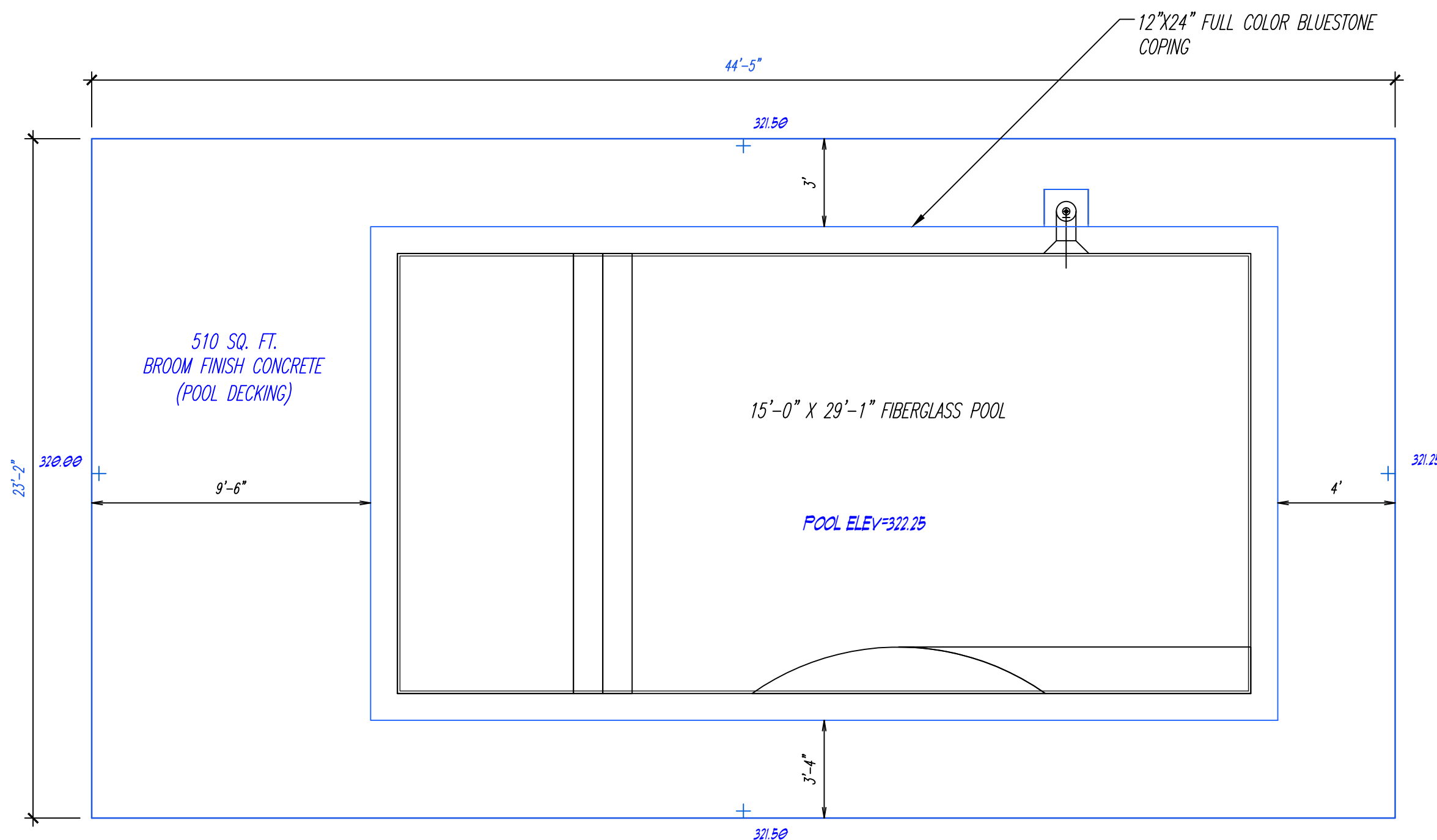

Blank space for notes or additional map details.

POOL DATA

DIMENSIONS	29'-1" X 15'-0" RECTANGLE FIBERGLASS POOL
PERIMETER	88 LF
SURFACE AREA	436 SQ.FT.
GALLONAGE	10,789 GALLONS
DEPTHS	3'-4" TO 6'-2"
FILTER RATE	30 GPM
TURNOVER TIME	6 HOURS
POOL DECK AREA	510 SQ.FT.

PROJECT NAME

CUSTOMER	MARCELO CABROL & CAROLA ALVAREZ
ADDRESS	3940 WASHINGTON STREET KENSINGTON, MD, 20895
PHONE 1	202-256-1304
PHONE 2	carolaa2018@gmail.com
EMAIL	-
COUNTY	13TH ELECTION DISTRICT, MONTGOMERY COUNTY
SUBDIVISION	KENSINGTON PARK
LOT DATA	LOT 54 & PARTS OF LOT 65 & 66, BLOCK 13
TAX ID#	13-01020550

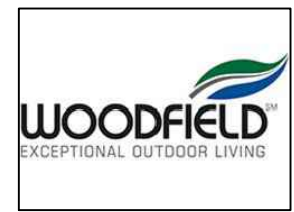

WOODFIELD OUTDOORS
 2112 Belair Road, Ste 3
 Fallston, Maryland 21047
 Phone: (443) 299-6500
 MHIC: 121071

HARDSCAPE LAYOUT V1

HSL

KEY

- WOODED AREA
- DRAINAGE DIRECTION
- SPOT ELEVATIONS
- POOL DEPTHS
- RADIUS CENTER MARK
- POOL WALL RETURNS
- POOL LIGHTS
- POOL SKIMMERS
- POOL CHANNEL DRAIN
- FENCE
- EXISTING ELEVATIONS
- PROPOSED ELEVATIONS
- FLOOR RETURN
- ELECTRIC OUTLET
- TRIM TILE
- ROPE FLOAT
- INDICATION OF 90° JUNCTION
- PIN (REBAR OR OTHER)
- DRAIN LINE
- COURTESY OUTLET
- CUT LINE - HARDSCAPE
- 8" DIAM. MAIN DRAIN

SCHEDULE OF FINISHES	
TYPE OF POOL	FIBERGLASS POOL-WYLELA BEACH -COLOR: GRANITE
POOL COPING	12"x24" BLUESTONE FULL COLOR
WATERLINE TILE	6X6 STANDARD TILE
POOL DECKING	BROOM FINISH CONCRETE
FENCE	5' HIGH - POOL CODE COMPLIANT

VICINITY MAP

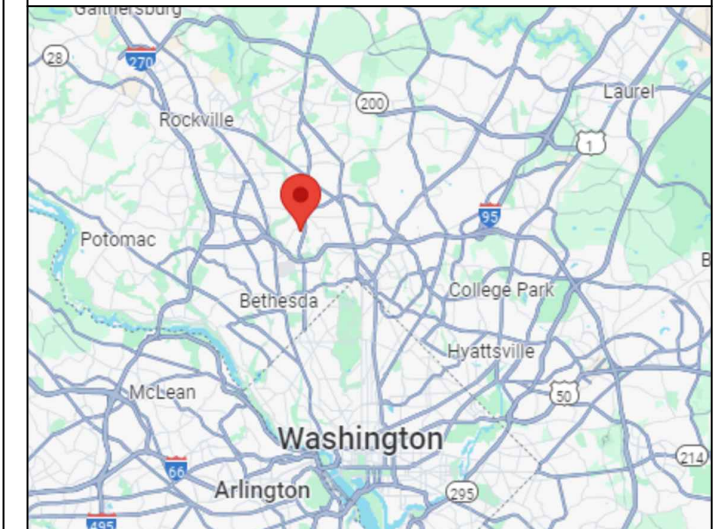

POOL DATA

DIMENSIONS	29'-1" X 15'-0" RECTANGLE FIBERGLASS POOL
PERIMETER	88 LF
SURFACE AREA	436 SQ.FT.
GALLONAGE	10,789 GALLONS
DEPTHS	3'-4" TO 6'-2"
FILTER RATE	30 GPM
TURNOVER TIME	6 HOURS
POOL DECK AREA	510 SQ.FT.

PROJECT NAME

CUSTOMER	MARCELO CABROL & CAROLA ALVAREZ
ADDRESS	3940 WASHINGTON STREET KENSINGTON, MD, 20895
PHONE 1	202-256-1304
PHONE 2	carolaa2018@gmail.com
EMAIL	-
COUNTY	13TH ELECTION DISTRICT, MONTGOMERY COUNTY
SUBDIVISION	KENSINGTON PARK
LOT DATA	LOT 54 & PARTS OF LOT 65 & 66, BLOCK 13
TAX ID#	13-01020550

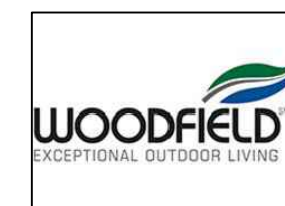

WOODFIELD OUTDOORS
 2112 Belair Road, Ste 3
 Fallston, Maryland 21047
 Phone: (443) 299-6500
 MHIC: 121071

PHOTOGRAPHS V1

PH

PHOTOGRAPHS



*EXISTING 3 STORY FRAME HOUSE
(FRONT VIEW)*





*EXISTING 3 STORY FRAME HOUSE
(LEFT SIDE)*



*EXISTING 3 STORY FRAME HOUSE
(LEFT SIDE)*

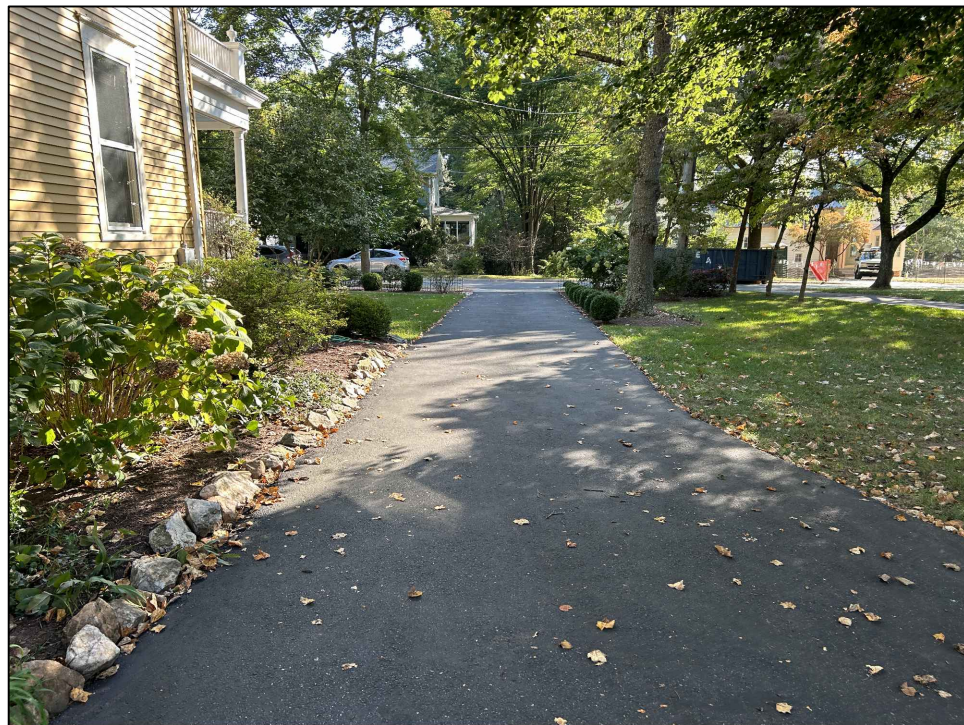

*EXISTING 3 STORY FRAME HOUSE
(LEFT SIDE)*



*EXISTING 3 STORY FRAME HOUSE
(RIGHT SIDE)*

VICINITY MAP

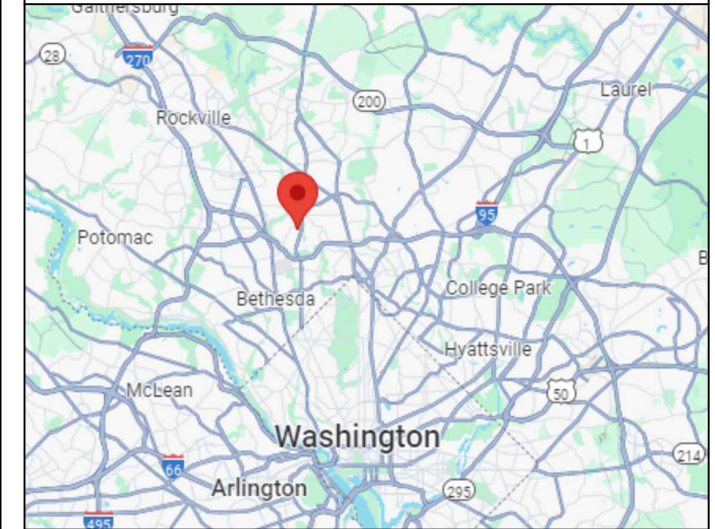

POOL DATA

DIMENSIONS	29'-1" X 15'-0" RECTANGLE FIBERGLASS POOL
PERIMETER	88 LF
SURFACE AREA	436 SQ.FT.
GALLONAGE	10,789 GALLONS
DEPTHS	3'-4" TO 6'-2"
FILTER RATE	30 GPM
TURNOVER TIME	6 HOURS
POOL DECK AREA	510 SQ.FT.

PROJECT NAME

CUSTOMER	MARCELO CABROL & CAROLA ALVAREZ
ADDRESS	3940 WASHINGTON STREET KENSINGTON, MD, 20895
PHONE 1	202-256-1304
PHONE 2	carolaa2018@gmail.com
EMAIL	-
COUNTY	13TH ELECTION DISTRICT, MONTGOMERY COUNTY
SUBDIVISION	KENSINGTON PARK
LOT DATA	LOT 54 & PARTS OF LOT 65 & 66, BLOCK 13
TAX ID#	13-01020550

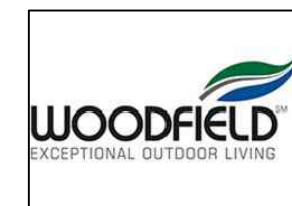

WOODFIELD OUTDOORS
2112 Belair Road, Ste 3
Fallston, Maryland 21047
Phone: (443) 299-6500
MHIC: 121071

PHOTOGRAPHS V1

PH

PHOTOGRAPHS





*EXISTING 3 STORY FRAME HOUSE
(RIGHT SIDE)*



*EXISTING 3 STORY FRAME HOUSE
(REAR SIDE)*



*EXISTING 1 STORY GARAGE
(FRONT VIEW)*

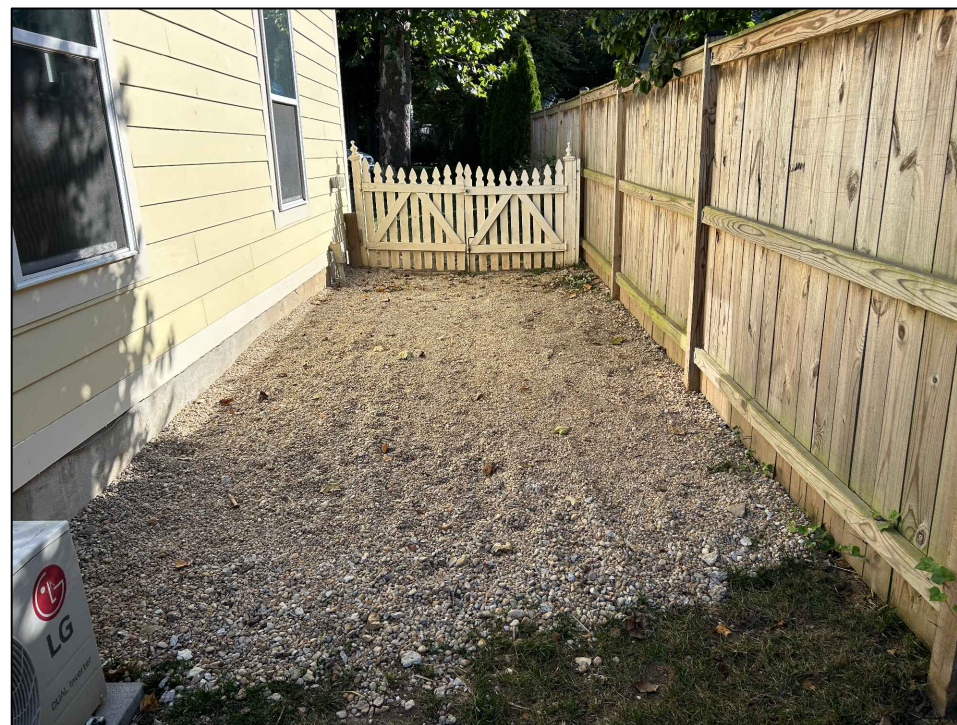

*EXISTING 1 STORY GARAGE
(SIDE VIEW)*

VICINITY MAP

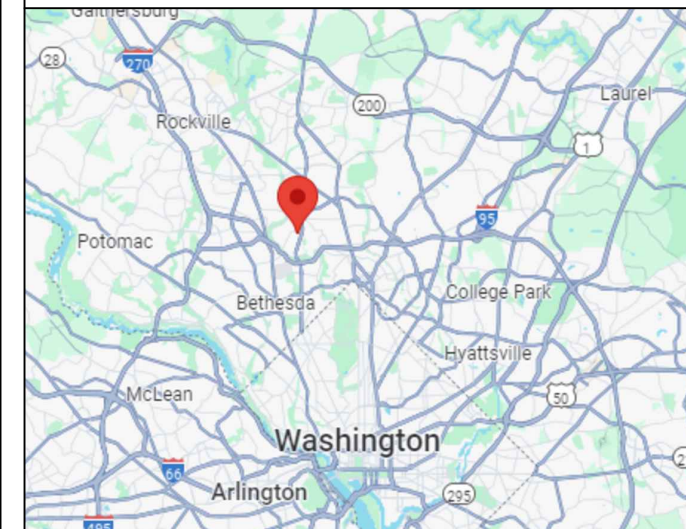

POOL DATA

DIMENSIONS	29'-1" X 15'-0" RECTANGLE FIBERGLASS POOL
PERIMETER	88 LF
SURFACE AREA	436 SQ.FT.
GALLONAGE	10,789 GALLONS
DEPTHS	3'-4" TO 6'-2"
FILTER RATE	30 GPM
TURNOVER TIME	6 HOURS
POOL DECK AREA	510 SQ.FT.

PROJECT NAME

CUSTOMER	MARCELO CABROL & CAROLA ALVAREZ
ADDRESS	3940 WASHINGTON STREET KENSINGTON, MD, 20895
PHONE 1	202-256-1304
PHONE 2	carolaa2018@gmail.com
EMAIL	-
COUNTY	13TH ELECTION DISTRICT, MONTGOMERY COUNTY
SUBDIVISION	KENSINGTON PARK
LOT DATA	LOT 54 & PARTS OF LOT 65 & 66, BLOCK 13
TAX ID#	13-01020550

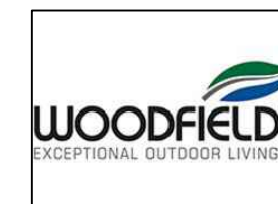

WOODFIELD OUTDOORS
2112 Belair Road, Ste 3
Fallston, Maryland 21047
Phone: (443) 299-6500
MHIC: 121071

PHOTOGRAPHS V1

PH





EXISTING FENCE TO BE UPGRADED



*EXISTING 1 STORY GARAGE
(FRONT VIEW)*



POOL AREA VIEW



POOL AREA VIEW

VICINITY MAP

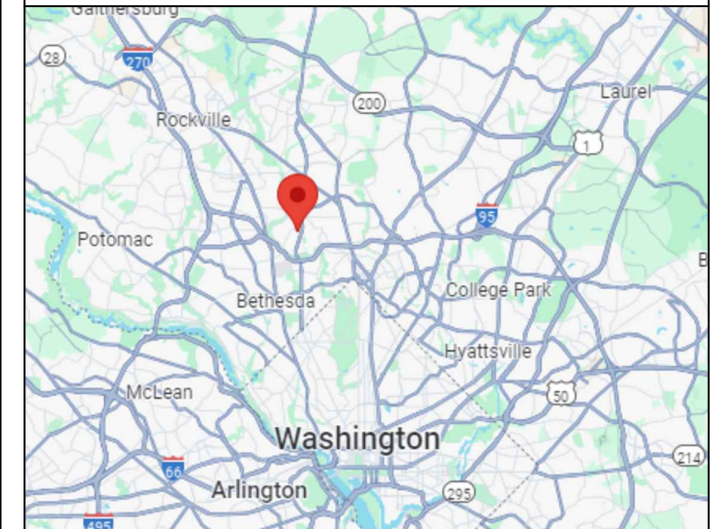

POOL DATA

DIMENSIONS	29'-1" X 15'-0" RECTANGLE FIBERGLASS POOL
PERIMETER	88 LF
SURFACE AREA	436 SQ.FT.
GALLONAGE	10,789 GALLONS
DEPTHS	3'-4" TO 6'-2"
FILTER RATE	30 GPM
TURNOVER TIME	6 HOURS
POOL DECK AREA	510 SQ.FT.

PROJECT NAME

CUSTOMER	MARCELO CABROL & CAROLA ALVAREZ
ADDRESS	3940 WASHINGTON STREET KENSINGTON, MD, 20895
PHONE 1	202-256-1304
PHONE 2	carolaa2018@gmail.com
EMAIL	-
COUNTY	13TH ELECTION DISTRICT, MONTGOMERY COUNTY
SUBDIVISION	KENSINGTON PARK
LOT DATA	LOT 54 & PARTS OF LOT 65 & 66, BLOCK 13
TAX ID#	13-01020550

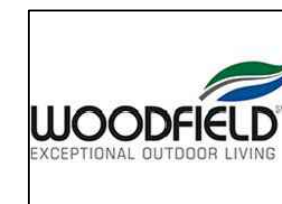

WOODFIELD OUTDOORS
2112 Belair Road, Ste 3
Fallston, Maryland 21047
Phone: (443) 299-6500
MHIC: 121071

PHOTOGRAPHS V1

PH





DEPARTMENT OF PERMITTING SERVICES

Marc Elrich
County Executive

Rabbiah Sabbakhan
Director

HISTORIC AREA WORK PERMIT APPLICATION

Application Date: 1/15/2025

Application No: 1100616
AP Type: HISTORIC
Customer No: 1512389

Affidavit Acknowledgement

The Contractor is the Primary applicant authorized by the property owner
This application does not violate any covenants and deed restrictions

Primary Applicant Information

Address 3940 WASHINGTON ST
KENSINGTON, MD 20895
Othercontact Woodfield Landscaping Inc.
Othercontact Woodfield Landscaping Inc. (Primary)

Historic Area Work Permit Details

Work Type ADD

Scope Installation of a 15'-0" by 29'-1" rectangle fiberglass inground swimming pool - to be filled by water truck. The pool will be surrounded by 510 sq ft of
of Work concrete pool decking. The existing fence on site will be replaced with 236 LN FT of 5' pool-compliant fencing.