



MEMORANDUM

To: Historic Preservation Commission

From: John Liebertz, Cultural Resource Planner III, Countywide Planning and Policy Division,
Montgomery Planning

Date: January 22, 2025

Re: An Amendment to the *Master Plan for Historic Preservation*: COMSAT Laboratories, 22300
Comsat Drive, Clarksburg, MD (M: 13-59)

Description: The Historic Preservation Commission (HPC) will receive public testimony, hold a worksession, and provide recommendations to the Planning Board and County Council on the evaluation of COMSAT Laboratories for listing in the *Master Plan for Historic Preservation*.

Summary:

- The COMSAT Laboratories property is approximately 205 acres and zoned EOF-.75H-100T, Employment Office.
- In 2024, the Maryland Historical Trust found the property to be eligible for listing in the National Register of Historic Places.
- Historic Preservation staff reaffirms the Historic Preservation Commissions (HPC) findings in 2005 that COMSAT Laboratories satisfied six of the nine designation criteria as outlined in 24A-3(b), Historic Resources Preservation, Montgomery County Code.
- Staff recommends that the HPC finds that the property continues to meet the designation criteria, proposes an environmental setting of 33.47 acres, and transmits their recommendation to the Planning Board.
- Montgomery Planning and the Historic Preservation Office will not be recommending the listing of COMSAT Laboratories to the *Master Plan for Historic Preservation* as part of the *Clarksburg Gateway Sector Plan*.

Recommendation:

Staff recommends that the Historic Preservation Commission (HPC):

1. Finds that COMSAT Laboratories satisfies six designation criteria as listed in 24A-3(b), Historic Resources Preservation, Montgomery County Code;
2. Proposes an environmental setting of 33.47 acres; and,
3. Transmits their recommendation to the Planning Board.

Attachments:

Attachment A: Environmental Setting

Attachment B: MIHP Form (2004)

Attachment C: Letter from the Maryland Historical Trust

Attachment D: COMSAT Laboratories: 1985 Annual Report

Overview

As part of the *Clarksburg Gateway Sector Plan*, Montgomery Planning evaluated several potential sites and districts for listing in the *Master Plan for Historic Preservation*. This included the review of the COMSAT Laboratories (M: (#13-59) at 22300 COMSAT Drive. COMSAT Laboratories, built in 1969, is an early work of world-renowned master architect Cesar Pelli that epitomized “high-technology” architectural design which became prevalent along the I-270 corridor. The research and development advances at COMSAT revolutionized communication technology.

In 1994, the County Council adopted the *Clarksburg Master Plan* (1994) that envisioned the property as a major employment and transit center. At that time, the 24-year-old building remained actively occupied by COMSAT with no threat of demolition. The building’s age paired with its active use and a lack of realization of its significance led to no evaluation of the site for historic designation as part of that plan.

In the early 2000s, COMSAT Laboratories was considered for listing in the *Master Plan for Historic Preservation* absent an area-wide sector plan due to discussions of redevelopment and demolition of the building. Between 2004 and 2006, the Historic Preservation Commission (HPC) and Planning Board held public hearings and worksessions to evaluate whether COMSAT Laboratories satisfied designation criteria as outlined in §24A-3: Historic Resources Preservation, Montgomery County Code. The HPC found that COMSAT Laboratories satisfied multiple designation criteria and recommended the resource be listed in the *Master Plan for Historic Preservation* with a proposed environmental setting of 33.47 acres. While the Planning Board forwarded the designation to the County Council with a negative recommendation, the County Council never scheduled a public hearing or worksession on this matter leaving the question of its preservation unclear. COMSAT Laboratories has been largely vacant since 2007.

The *Clarksburg Gateway Sector Plan* intends to address the preservation of the building as part of a comprehensive analysis of the plan area. The Planning Board approved the evaluation of COMSAT Laboratories for listing in the *Master Plan for Historic Preservation* as part of the Scope of Work in June 2023. After recommendations by the HPC and Planning Board, the designation process ultimately will conclude with a vote by the County Council on whether or not the property should be listed to the *Master Plan for Historic Preservation*. This decision will provide a definitive answer to the property owner, preservation advocates, and county residents on the question of historic designation.

Historic Preservation Commission and Planning Board’s Roles in Amendments to the Master Plan for Historic Preservation

The Historic Preservation Commission (HPC) has an important and defined role in the designation process. The HPC’s responsibilities include the research and evaluation of historic resources, and recommendations to the Planning Board for the listing of certain sites and districts to the *Master Plan for Historic Preservation*. These recommendations are, by law, advisory in nature. The HPC’s recommendation must be based on the designation criteria outlined in §24A-3(b), Historic Resources Preservation, Montgomery County Code.

After receiving the recommendation from the HPC, the Planning Board holds a public hearing and worksession to make its own determination, using the same designation criteria, and balancing the importance of the historic property with other public interests. The Planning Board forwards their recommendation to the County Executive and County Council for their consideration. The County Council ultimately decides if a property is listed to the *Master Plan for Historic Preservation*.

Administrative History of the Designation Process for COMSAT Laboratories (2004-2006)

On November 1, 2004, the Historic Preservation Commission (HPC) received a nomination to list COMSAT Laboratories by Professors Isabelle Gournay and Mary Corbin Sies of the University of Maryland. Between February and April 2005, the commission held public hearings and worksessions on the proposed amendment to the *Master Plan for Historic Preservation*. On April 13, 2005, the HPC found that COMSAT Laboratories met six designation criteria as outlined in §24A-3(b), Historic Resources Preservation, Montgomery County Code. This included the following criteria for historical and cultural significance and architectural and design significance:

- 1.A: The historic resource has character, interest or value as part of the development, heritage, or cultural characteristics of the county, state or nation;
- 1.D: The historic resource exemplifies the cultural, economic, social, political, or historic heritage of the county and its communities;
- 2.A: The historic resource embodies the distinctive characteristics of a type, period or method of construction;
- 2.B: The historic resource represents the work of a master;
- 2.C: The historic resource possess high artistic value; and
- 2.E: The historic resource represents an established and familiar visual feature of the neighborhood, community or county due to its singular physical characteristic or landscape.

The HPC recommended an environmental setting (historic site boundary) of 33.47 acres. The proposed setting intended to preserve important viewsheds of the COMSAT Laboratories from I-270 and retain views of the surrounding open greenspace from the building. The commission recommended that the entire building be designated, but that non-historic additions be identified as non-contributing elements to facilitate demolition and/or alterations. In addition, the HPC noted that the relationship of the building to I-270 as the primary historic feature and classified the non-public portions of the building that faced away from the interstate as secondary with the potential for a higher-degree of alteration and redevelopment. All other smaller and detached buildings and structures on the property were not included in the environmental setting.

The Planning Board held a public hearing and worksession on the proposed designation of COMSAT Laboratories in May and July 2005, respectively. On July 7, 2005, the Board voted against the proposed designation and found that listing the property in the *Master Plan for Historic Preservation* had the potential to impair the implementation of the *Clarksburg Master Plan* (1994). Specifically, the Board stated preservation would inhibit the intensification of development for the site. The Board shared two other secondary concerns: 1) the consideration of the proposed designation outside the context of a comprehensive master plan created unpredictable scenarios for property owners; and 2) the designation of resources less than 50 years old was unusual albeit not prohibited by code. As noted in the *Planning Board (Final) Draft Amendment to the Master Plan for Historic Preservation: COMSAT Laboratories, 22300 Comsat Drive, Clarksburg, MD*:

..., the Planning Board finds that, while the COMSAT Laboratories Building does have architectural significance, this is not a sufficient or compelling reason to support historic designation. The Board finds that this is especially true when balanced with the importance of the property in achieving goals of the Clarksburg Master Plan to provide signature sites along I-270 for major employment centers.

After the Planning Board voted to deny designation of the property, the Board did not send an amendment recommending against listing the property in the *Master Plan for Historic Preservation* to the County Council. The Board held an additional public worksession on February 16, 2006, to address this issue and voted to forward the amendment to the County Council. On March 7, 2006, the Board transmitted the *Planning Board (Final) Draft Amendment to the Master Plan for Historic Preservation: COMSAT Laboratories, 22300 Comsat Drive, Clarksburg, MD* to the County Executive and County Council. The County Council never held or scheduled public hearings or worksessions to address the proposed amendment.

Current Evaluation of COMSAT Laboratories and New Information

On June 22, 2023, the Planning Board approved the scope for a new master plan for the Clarksburg Area. This new *Clarksburg Gateway Sector Plan* is an amendment to the *Clarksburg Master Plan* (1994). This Sector Plan focuses on a portion of the adopted Master Plan's Transit Corridor District and surrounding areas. The boundary of the Sector Plan is part of the I-270 corridor—a significant employment resource for the county and the region. The Sector Plan will examine undeveloped areas—specifically, the eastern side of I-270—that have remained largely unchanged in the last 30 years. Alongside extensive engagement with residents, business owners, and other interested parties, Montgomery Planning staff will research existing conditions and trends, evaluate land use, zoning, housing needs, transportation, environmental conditions, and historic resources, and propose recommendations to achieve a new vision for this section of Clarksburg. The Planning Board approved the evaluation of COMSAT Laboratories for listing in the *Master Plan for Historic Preservation* as part of the Scope of Work for this Sector Plan in June 2023.

Montgomery Planning staff reaffirms the findings of the Historic Preservation Commission and Planning Board in 2005 that COMSAT Laboratories has historical and architectural significance as outlined in §24A-3(b), Historic Resources Preservation, Montgomery County Code. Historic Preservation staff conducted limited new outreach and documentation to augment the wide breath of existing documentation.

As part of this effort, Staff requested that the Maryland Historical Trust (MHT, State Historic Preservation Office) provide a determination of eligibility for COMSAT Laboratories for listing in the National Register of Historic Places. The National Register is the official Federal list of districts, sites, buildings, structures, and objects significant in American history, architecture, archeology, engineering, and culture. National Register properties have significance to the history of their community (local level), state, or the nation. Professors Isabelle Gournay and Mary Corbin Sies of the University of Maryland submitted a National Register nomination form to MHT in 2005, but the documentation had been prepared for inventory purposes only and was never formally reviewed for eligibility by MHT. While the National Register designation criteria are different than the criteria for listing in the *Master Plan for Historic Preservation*, the MHT's expertise, evaluation, and assessment of the property stands as an important measure for the architectural and historical significance of the resource. Their assessment confirms the significance of the property at the local, state, and national levels.

MHT determined that COMSAT Laboratories is eligible for listing in the National Register of Historic Places under **Criteria A** and **C**. Under **Criterion A: Event**, properties are eligible for the National Register if they are associated with events that have made a significant contribution to the broad patterns of our history. MHT found COMSAT Laboratories eligible for listing in the areas of Science, Engineering, and Communication at the national level of significance due to its role in the founding of modern communications technology. Under **Criterion C: Design/Construction**, properties are eligible

for the National Register if they embody the distinctive characteristics of a type, period, or method of construction, or that represent the work of a master, or that possess high artistic value, or that represent a significant and distinguishable entity whose components may lack individual distinction. MHT found COMSAT Laboratories eligible as the work of a master at the state level of significance due to its association with Cesar Pelli and the use of architectural features that would later characterize “high-technology” design.

Please refer to Attachment C: MHT Letter for the letter from Elizabeth Hughes, Director, Maryland Historical Trust, to Rebecca Ballo, Historic Preservation Supervisor, Montgomery Planning, dated September 12, 2024.

As part of the public outreach for the designation, Montgomery Preservation Inc. facilitated discussions between Historic Preservation staff and the COMSAT Alumni & Retirees Association (COMARA). Maury Mechanick, COMARA President, shared with the team a robust oral history project that collates the recollections of former employees. Please see the COMARA website (<https://www.comara.org/i-remember-comsat/>) for the most up-to-date information as the organization continues to publish new information and oral histories. In addition, the organization shared the *COMSAT Laboratories: 1985 Annual Report* (Attachment D) that provides detailed information about the scientific and technical achievements. This information paired with the oral histories confirms and expands upon the vast historical significance associated with COMSAT Laboratories in the fields of science, engineering, and communications.

Designation Criteria

Staff finds that the subject property continues to satisfy six designation criteria as listed in §24A-3(b), Historic Resources Preservation, Montgomery County Code. This recommendation aligns with the finding of the Planning Staff and the Historic Preservation Commission (HPC) as part of their review of the property in 2005. The commission found that the resource satisfied the following criteria for historical and cultural significance and architectural and design significance:

- 1.A Historical and cultural significance. The historic resource has character, interest or value as part of the development, heritage, or cultural characteristics of the county, state, or nation.
- 1.D Historical and cultural significance. The historic resource exemplifies the cultural, economic, social, political, or historic heritage of the county and its communities.
- 2.A Architectural and design significance. The historic resource embodies the distinctive characteristics of a type, period or method of construction.
- 2.B Architectural and design significance. The historic resource represents the work of a master.
- 2.C Architectural and design significance. The historic resource possesses high artistic value.
- 2.E Architectural and design significance. The historic resource represents an established and familiar visual feature of the neighborhood, community or county due to its singular physical characteristics or landscape.

As noted in the *Planning Board (Final) Draft Amendment to the Master Plan for Historic Preservation: COMSAT Laboratories, 22300 Comsat Drive, Clarksburg, MD* from 2005, the HPC provided the following justification for their decision:

- COMSAT Laboratories represents the trend toward high-technology innovation in industry in Montgomery County, the nation, and international spheres.
- COMSAT Laboratories represents the advance of the commercial artificial satellite industry throughout the world. This advance was spearheaded, from a research and design perspective, in Montgomery County by the work undertaken at COMSAT Laboratories.
- COMSAT Laboratories has political origins tied to the actions of both Presidents Kennedy and Johnson. In addition, it helped define the economic heritage of the County for four decades.
- COMSAT Laboratories represents the International Style in its design esthetic and is an early example of the “high-tech” architecture that came to define the corporate “campus”.
- COMSAT Laboratories is an early design by world-acclaimed architect, Cesar Pelli. He created the design as Director of Design for Daniel, Mann, Johnson, and Mendenhall (DMJM).
- COMSAT Laboratories epitomized the “machine in the garden” ideal of a futuristic building set within a naturalized setting.
- COMSAT Laboratories is one of the most easily identifiable buildings along the I-270 corridor in Montgomery County. It is a building that represents Montgomery County as an undisputed leader in high technology industry nationwide.

Please see [Attachment B: MIHP Form](#) for a detailed analysis of the resource’s historic and architectural significance.

COMSAT Laboratories continues to be recognized as the setting for significant contributions to advancements in the fields of science, engineering, and technology at the national level, as well as its role in the development of the Interstate 270 corridor in Montgomery County. The building remains a self-identified and significant early work of now deceased master architect Cesar Pelli who died in 2019. Pelli stated in 2004 that “[COMSAT Laboratories] is a unique project and one of my most important designs while I was Director of Design at Daniel, Mann, Johnson, and Mendenhall (DMJM).” While the death of Pelli has no bearing on the evaluation of significance per the designation criteria, the understanding of his architectural works continues to be augmented after his death.

Planning Staff Findings — Clarksburg Gateway Sector Plan

Montgomery Planning studied the preservation and adaptive reuse as part of the *Clarksburg Gateway Sector Plan*. The Department will not recommend listing the building to the *Master Plan for Historic Preservation* after a thorough analysis of design scenarios, site development, and a financial feasibility analysis. HR&A Advisors—a real estate and economic development consultant—prepared the following report: <https://montgomeryplanningboard.org/wp-content/uploads/2024/11/Clarksburg-Adaptive-Reuse-Feasibility-Report-FINAL-10.16.24.pdf>.

On November 21, 2024, Planning Staff and HR&A presented their findings to the Planning Board. Video of the presentation is available online: <https://www.youtube.com/live/LnCXTGQC5ho?t=875s>.

Conclusion

Staff recommends that the Historic Preservation Commission (HPC):

1. Finds that COMSAT Laboratories satisfies six designation criteria as listed in 24A-3(b), Historic Resources Preservation, Montgomery County Code;
2. Proposes an environmental setting of 33.47 acres; and,
3. Transmits their recommendation to the Planning Board.

Attachment A: Environmental Setting



Figure 1: Proposed environmental setting for COMSAT Laboratories, Clarksburg, Montgomery County, Maryland. This environmental setting of 33.47 acres matches the boundary proposed by the Historic Preservation Commission in 2005.

Attachment B: MIHP Form (2004)

Maryland Historical Trust Maryland Inventory of Historic Properties Form

Inventory No. MC-13-59

1. Name of Property

historic	COMSAT Laboratories
other	

2. Location

street and number	22300 Comsat Drive	___	not for publication
city, town	Clarksburg, MD	___	vicinity
county	Montgomery County		

3. Owner of Property (give names and mailing addresses of all owners)

name	LCOR Incorporated		
street and number	6550 Rock Spring Drive, Suite 280	telephone	301-897-0002
city, town	Bethesda	state	MD
		zip code	20817

4. Location of Legal Description

courthouse, registry of deeds, etc.	Montgomery County Land Records	liber 16925	folio 574
city, town	Rockville, MD	tax map EV33	tax parcel N888 tax ID number D02: 00018631

5. Primary Location of Additional Data

Contributing Resource in National Register District
 Contributing Resource in Local Historic District
 Determined Eligible for the National Register/Maryland Register
 Determined Ineligible for the National Register/Maryland Register
 Recorded by HABS/HAER
 Historic Structure Report or Research Report at MHT
 Other: Cesar Pelli & Associates, Architects

6. Classification

Category	Ownership	Current Function		Resource Count	
				Contributing	Noncontributing
<input type="checkbox"/> district	<input type="checkbox"/> public	<input type="checkbox"/> agriculture	<input type="checkbox"/> landscape	<u>1</u>	<input type="checkbox"/> buildings
<input checked="" type="checkbox"/> building(s)	<input checked="" type="checkbox"/> private	<input checked="" type="checkbox"/> commerce/trade	<input type="checkbox"/> recreation/culture	<u>1</u>	<input type="checkbox"/> sites
<input type="checkbox"/> structure	<input type="checkbox"/> both	<input type="checkbox"/> defense	<input type="checkbox"/> religion		<input type="checkbox"/> structures
<input checked="" type="checkbox"/> site		<input type="checkbox"/> domestic	<input type="checkbox"/> social		<input type="checkbox"/> objects
<input type="checkbox"/> object		<input type="checkbox"/> education	<input type="checkbox"/> transportation	<u>2</u>	<input type="checkbox"/> Total
		<input type="checkbox"/> funerary	<input type="checkbox"/> work in progress		
		<input type="checkbox"/> government	<input type="checkbox"/> unknown		
		<input type="checkbox"/> health care	<input type="checkbox"/> vacant/not in use		
		<input type="checkbox"/> industry	<input type="checkbox"/> other:		

Number of Contributing Resources previously listed in the Inventory

7. Description

Condition

excellent deteriorated
 good ruins
 fair altered

Prepare both a one paragraph summary and a comprehensive description of the resource and its various elements as it exists today.

Section 7: Narrative description

Summary Paragraph

COMSAT Laboratories (1968-69) is located in Clarksburg, Maryland, 34.41 miles northwest of the White House¹, just east of and overlooking I-270. Designed by the world-renowned master architect Cesar Pelli, at that time Director of Design for Daniel, Mann, Jackson, Mendenhall (DMJM), COMSAT Laboratories was an early and iconic example of the High Technology design that came to define technology research corridors in Montgomery County and elsewhere in the nation. The building complex, a virtual "machine in the garden,"² popularized several elements of the High-Tech design that dominated the late twentieth century. The building's transparent, futuristic form, resting lightly upon a pastoral landscape, symbolized the necessary, but complicated relationship of technology amid nature. The building cannot be separated from a naturalistic setting, but neither can a building representing the future meld unnoticed into the landscape. The landscape is a character-defining features of COMSAT Laboratories, since it contributes greatly to the physical character of the resource. In terms of its plan, COMSAT laboratories featured lineal design with spaces deployed along a central spine for circulation, flexible planning and separation of laboratory spaces, separate mechanical penthouses providing services to each wing, and provision for expansion of the complex. Its streamlined exterior, which Pelli likened to "airline construction and esthetics," established a new design vocabulary for High Technology industries. The principal facades were enclosed by a tight, flush aluminum and glass skin, a glittering membrane that stretched continuously over and around the structure. Two kinds of windows contributed to the machine-like effect: floor to ceiling glazing along the spine and catwalk in clear glass separated by thin aluminum mullions, and, in the laboratory wings, smaller rectangular office windows of solar glass and curved corners, set flush with the aluminum skin and sealed with a neoprene gasket. Pelli designed the complex for views: with its western glass corridor, serving as a secondary connector between the administrative and laboratory wings, COMSAT Laboratories was designed to be seen from the highway, a "light-looking, high-tech form sitting on a pristine landscape," representing the future promise of the communications technology that would enable individuals worldwide to see a man walking on the moon.³ From the interior, the principal spaces were designed to give employees the best views of the surrounding pastoral landscape. Although COMSAT Laboratories has had additions and alterations, they have occurred on the eastern and southern ends of the complex. The public facades are practically unchanged from their appearance in 1969.

Inventory No. MC 13-59

8. Significance

Period	Areas of Significance	Check and justify below		
<input type="checkbox"/> 1600-1699	<input type="checkbox"/> agriculture	<input type="checkbox"/> economics	<input type="checkbox"/> health/medicine	<input type="checkbox"/> performing arts
<input type="checkbox"/> 1700-1799	<input type="checkbox"/> archeology	<input type="checkbox"/> education	<input type="checkbox"/> industry	<input type="checkbox"/> philosophy
<input type="checkbox"/> 1800-1899	<input checked="" type="checkbox"/> architecture	<input checked="" type="checkbox"/> engineering	<input type="checkbox"/> invention	<input checked="" type="checkbox"/> politics/government
<input checked="" type="checkbox"/> 1900-1999	<input type="checkbox"/> art	<input type="checkbox"/> entertainment/ recreation	<input type="checkbox"/> landscape architecture	<input type="checkbox"/> religion
<input type="checkbox"/> 2000-	<input checked="" type="checkbox"/> commerce	<input type="checkbox"/> ethnic heritage	<input type="checkbox"/> law	<input checked="" type="checkbox"/> science
	<input checked="" type="checkbox"/> communications	<input type="checkbox"/> exploration/ settlement	<input type="checkbox"/> literature	<input type="checkbox"/> social history
	<input type="checkbox"/> community planning		<input type="checkbox"/> maritime history	<input type="checkbox"/> transportation
	<input type="checkbox"/> conservation		<input type="checkbox"/> military	<input type="checkbox"/> other: _____

Specific dates

Architect/Builder

¹ Distance calculated by Mapquest at www.mapquest.com, (accessed 10-23-04).

² This idea was popularized in a major scholarly text in 1964; Leo Marx, *The Machine in the Garden: Technology and the Pastoral Ideal in America* (New York: Oxford, 1964).

³ Cesar Pelli, Email communication with the Historic Preservation Section, 21 September 2004.

Maryland Historical Trust

Maryland Inventory of Historic Properties Form

Inventory No. MC-13-59

Name
Continuation Sheet

Number 8 Page 1

Construction dates 1967 (design) 1968-69 (construction)

Evaluation for:

National Register Maryland Register not evaluated

Montgomery County Master Plan for Historic Sites

Prepare a one-paragraph summary statement of significance addressing applicable criteria, followed by a narrative discussion of the history of the resource and its context. (For compliance projects, complete evaluation on a DOE Form – see manual.)

Significance Summary

The United States would not have become the world leader in artificial communication satellites were it not for the work undertaken at COMSAT Laboratories. Real-time international phone communication and international, live television broadcast - aspects of global communication technology that we take for granted today - were pioneered by the scientists, researchers, and technicians at COMSAT Laboratories in the 1960s and 1970s. The building at 22300 Comsat Drive that housed the Research and Development (R&D) functions of COMSAT since 1969 stands as an icon of avant-garde global research and the harbinger of the "high technology corridor" that came to define upper Montgomery County. The building is unquestionably one of the purest "high-technology" architectural statements in Montgomery County, a product both of the work that went on there and the aesthetic intention of its designer. Regarding the first point, the serene, futuristic COMSAT Laboratories reflects the decisive American step to not only to surpass the Russians in space, but also simultaneously to apply space technology to global, civilian communications. Regarding the second point, COMSAT Laboratories is an early work of Cesar Pelli, a living "master architect" with a worldwide practice and reputation. The building is Maryland's only commercial building by Cesar Pelli and one of only four buildings by Cesar Pelli standing in metropolitan Washington: The only other Maryland example is a Bethesda residence designed in the 1990s. Virginia is the site of Cesar Pelli's Reagan Washington National Airport structure, completed circa 1995 and an; elegant but less conspicuous office building addition was designed by Pelli for the Investment Building at 1900 K Street.⁴ COMSAT Laboratories holds an important place in Cesar Pelli's body of work according both to highly respected architectural critics and to Cesar Pelli himself. After COMSAT's 1967 design, Pelli went on to make an international reputation for himself by continuing to design "High Tech" buildings that picked up on COMSAT's origins and defied current norms. Design ideas experimented at COMSAT and honed on later buildings include: 1) Buildings sheathed in newer materials that exhibited tighter building skins. 2) Buildings where the extent of glass curtain-wall technology was stretched. 3) Buildings where the core designs are focused around the standpoint of circulation. 4) Certain buildings that perpetuated the notion of the machine in the garden. In 1995, as a result of his consistently excellent architectural works, Cesar Pelli was awarded the American Institute of Architect's Gold Medal, the honor of being judged the most accomplished architect in the world. In a written response to questions posed by the Historic Preservation Section of the Montgomery County Historic Preservation Commission, Cesar Pelli stated that he felt the most significant aspect of COMSAT Laboratories is its standing as "a very early example of high-technology design; an architectural direction that has become very strong, perhaps dominant, in the last 20 years." Cesar Pelli affirmed that his design was an important, successful investigation in "aesthetics, technology and building planning" and that it served as a model to him for several future projects.⁵ The building not only laid the groundwork for future High-Tech architecture (which consistently employed aluminum skins and metal-based glass curtain walls) but most certainly set the stage for the development of I-270 as Montgomery County's high technology corridor.

⁴ Benjamin Forgey, "Alluring Curves: Cesar Pelli's K Street Beauty is a Welcome Sight," *Washington Post*, August 3, 1996, C 1.

⁵ Cesar Pelli to Historic Preservation Section, memorandum, September 21, 2004.

9. Major Bibliographical References

Inventory No. MC-13-59

See attachment

10. Geographical Data

Acreage of surveyed property Approximately 150 acres
Acreage of historical setting Approximately 200 acre
Quadrangle name Germantown, MD Quadrangle scale: 7.5

Verbal boundary description and justification

See attached GIS map as description. It shows the associated tax parcel of the property, with its legal boundaries.

11. Form Prepared by

Name/title Isabelle Gournay, Ph.D., Associate Professor, School of Architecture, Affiliated Faculty, Historic Preservation Program, University of Maryland and Mary Corbin Sies, Ph.D., Associate Professor, Department of American Studies,

Affiliated Faculty, Historic Preservation Program, University of Maryland.

organization School of Architecture date 11/01/04
street & number University of Maryland Telephone 301-405-6304
city or town College Park State: Maryland

The Maryland Inventory of Historic Properties was officially created by an Act of the Maryland Legislature to be found in the Annotated Code of Maryland, Article 41, Section 181 KA, 1974 supplement.

The survey and inventory are being prepared for information and record purposes only and do not constitute any infringement of individual property rights.

return to: Maryland Historical Trust
DHCD/DHCP
100 Community Place
Crownsville, MD 21032-2023 410-514-7600

Maryland Historical Trust

Maryland Inventory of Historic Properties Form

Inventory No. MC-13-59

Name
Continuation Sheet

Number 7 Page 2

Site Plan and Landscaping

COMSAT Laboratories is located in Clarksburg, Maryland, 34.41 miles northwest of the White House, just east of and overlooking I-270 and north of W. Old Baltimore Road on more than 150 acres of pastoral, gently rolling land.⁶ Although the original 210 acres of property was bounded to the west by a major interstate highway, it was otherwise surrounded by dairy farms and open countryside in the late 1960s.⁷ The building complex was placed toward the western boundary of the site, where its striking high-tech massing would be visible from cars passing along I-270 (then I-70 S). It is accessible from Comsat Drive, which runs north from W. Old Baltimore Road about 1500 feet, then splits to form a service drive that runs along the east side of the complex, rejoining Comsat Drive north of the complex and just below where the drive curves to the east to join Shawnee Lane.

COMSAT Laboratories is situated about 1800 feet north of W. Old Baltimore Road and roughly 1000 feet east of I-270. The central spine of the complex is oriented north-south. To the south of the complex, the service drive provides access to 350 parking spaces for employees. Three additional driveways provide vehicle access to the loading docks and service areas on the east side of the complex. Another driveway, from Comsat Drive, provides a more formal access route to the main entrance, under a porte cochère motif formed by the projecting exhibition pavilion, and terminating in a visitor parking lot of 50 spaces to the north of the entrance. The land is gently rolling, peppered with maples, sycamores, and beech trees on the northern sides of the complex; when COMSAT was constructed, it was wooded with trees to the south, southeast, and southwest. The area to the east of the employee parking lot today hosts several large white satellite dishes, tilted every which way.

The landscaping, designed by Pelli and landscape architect Lester Collins, takes advantage of the natural features of the still rural site. Pelli intentionally placed the space-age design of his building in the center of a pastoral landscape, heightening the contrast between the machine-like building and the natural Maryland countryside. The minimal landscaping is indigenous to the area, consisting of small groupings and occasional strategic plantings of native trees that blend in with the surrounding farmland. No formal plantings or gardens embellish the complex. Today the large expanse of fields surrounding the complex and separating it from I-270 is tractor-mown. Additions to the south and east of the complex have resulted in a reduction in the amount of wooded acreage on the site. The four courtyards within the complex continue the theme of maintaining the natural features of the rural surrounds. They contain a sprinkling of native trees among mown field grass but are otherwise unplanted.

Original Plan

The original structure as constructed in 1968-69 included 254,000 square feet of floor space. According to current property records, the enclosed space has grown to 525,996 square feet. The original program was specified in a *Progressive Architecture* design award citation:

“a building complex to house all functions necessary to research, develop, and produce communications satellites. Basic program elements were: laboratories, research offices, spacecraft assembly area, administration offices, building and mechanical services. Other requirements: allowance for future expansion of facilities and services; flexible laboratory spaces; flexible mechanical and power distribution

⁶ Although the original documentation lists the acreage of the COMSAT property as 210 acres, the Maryland Department of Assessments and Taxation lists the current property land area as 154.24 acres. See Maryland Department of Assessments and Taxation, Real Property Data Search4 Website at http://sdatcert3.resiusa.org/rp_rewrite/, under 22300 Comsat Drive (accessed 10-23-04).

⁷ “Aluminum Membrane Envelops Satellite Laboratory,” 76; “Technological Imagery: Turnpike Version,” 70.

Maryland Historical Trust Maryland Inventory of Historic Properties Form

Inventory No. MC-13-59

Name
Continuation Sheet

Number 7 Page 3

system; consideration of present and future spacecraft dimensions; parking for 350 employees and 50 visitors.”⁸

As it turned out, the United States government and interested parties decided that it made the most economical and political sense to have the new satellites constructed by existing private industries, with COMSAT Laboratories providing all the research, development, and testing necessary to enable and support these production activities. The Comsat Laboratories building that fostered this global, commercial satellite industry consisted of a complex of spaces connected by a central corridor acting as a spine and facilitating circulation. The spine was oriented from north to south. Distributed to the west of the spine were four wings separated by three interior grassy courtyards. The northernmost wing contained administrative offices, as well as a mainframe computer on the first floor. The other three wings, identical from the outside, were configured similarly. Rows of office cubicles lined both the north and south exterior walls of each wing on both the first and second stories. The offices were separated from interior laboratory space by long corridors running the length of each wing. On each floor, the laboratory space—which was equipped with workbenches, sinks, and other infrastructure needed for global communications work—contained minimal permanent interior dividers so that personnel could configure the labs according to need. Because each lab wing was separated from the others by a courtyard, wings could assume different functions and work and change independently of one another. The first wing, for example, sheltered Wet Chemistry; the second hosted Microwave Communications, and the third housed the Research and Development of Spacecraft. To the west, the four wings were connected by a secondary corridor spanning on two stories the entire western façade. Five feet wide and lined with windows, these “catwalks” provided additional circulation between the wings. For security reasons, the courtyards were and are off limits to visitors.

Distributed to the east of the spine was a more complex set of spaces. From north to south, these included a roughly square wing that contained the lobby, a library, the auditorium, dining area, and a kitchen appendage to the south. This wing was divided from the next by an L-shaped courtyard. Originally open on the east side, but now enclosed by an addition, this is the courtyard that is accessible to employees. South of this courtyard was a short storage wing and loading dock. This was divided by a corridor from a longer wing that contained machine shops, plating, and maintenance facilities. Immediately adjacent was an assembly space. The southernmost wing, attached to the assembly space and configured as a long horizontal wing that paralleled the central spine, was the environmental test laboratory (ETL). The ETL was the largest space in the complex. It consisted of a warehouse with a 50-foot high ceiling and was equipped with a ten-ton crane used for the testing of satellites and antennae. The western half of the warehouse featured an enclosed second story-level balcony with windows from which the crane operators and other employees could look into the testing area. The testing space was furnished until recently with a huge vacuum chamber that simulated space conditions of 300 degrees below zero, and an anechoic chamber, a quiet room complete with cones designed to absorb both energy and satellite communications signals. Another function that took place in the ETL space involved the use of high-powered amplifiers to pump the sound of the space shuttle into the room in order to shake up the satellite components. These tests, along with tests on propulsion methods and rocket fuel efficiency, were undertaken to “space qualify” components of spacecraft and satellites. The 10,000-pound freight elevator used to reach the ETL from the main corridor is intact.

Crucial to the organization of the COMSAT complex was the central spine, a continuous glass corridor that terminated on the northern end in a dramatic cylindrical glassed-in two-story exhibition pavilion connected to the main complex by a canopy. The southernmost end of the spine led out to the employee parking lot. Pelli conceptualized the spine as a “line or street” that would organize a whole complex of functions in rectangular masses deployed to either side.⁹ In addition, the spine served as the “common room, meeting place, or room away from work” for the building’s scientists and employees.¹⁰ The long, linear glass corridor takes advantage along its length of views, both to the surrounding countryside and to the internal courtyards. The secondary glass corridor to the west completed circulation among and between the administrative and laboratory wings and unified the design linearity of the complex, making the main façade, visible

⁸ *Progressive Architecture* Design Awards 1968 Citation: COMSAT Laboratories (n.p.).

⁹ Kautz, “Cesar Pelli’s COMSAT Laboratories,” 23.

¹⁰ *Progressive Architecture* Citation, n.p.

Maryland Historical Trust

Maryland Inventory of Historic Properties Form

Inventory No. MC-13-59

Name
Continuation Sheet

Number 7 Page 4

from the highway, appear continuous. Future expansion of COMSAT Laboratories was planned for by extending the central spine to the south to link additional building components.

Beneath the three laboratory wings to the west of the central spine, there is a basement floor containing boiler and chiller rooms, and other mechanical services, including back-up generators for the mainframe computer, an electrical services hub, a photo lab, a print shop, and a vault. Above the second story of various wings of the building were penthouse spaces housing mechanical equipment. Each laboratory wing, for example, had an independent set of mechanical services, threaded vertically in the hollow walls separating the corridors from the interior laboratory spaces. Above the ETL, the roof was equipped with caps for anchoring satellite dishes; several crown the roof still today at the southeast corner of the complex.

Additions and Alterations

Since the original building was constructed in 1968-69, several additions and alterations have occurred. Two additions were made to the east side of the complex in the 1970s: a 6,000 square foot warehouse and an additional 1,000 square feet for the storage of hazardous chemicals.¹¹ In 1980, the architectural firm of Hellmuth, Obata & Kassabaum (HOK) was hired to prepare a master plan for further expansion of COMSAT Laboratories at the Clarksburg site. Following their plan, a "fifth wing" of 100,000 square feet (now known as the "fourth wing") was built in 1981-82 at the southwest corner of the complex. This four-story addition prompted the extension further south of the central spine and supplemented the office and laboratory space of the existing wings. Later on, a second phase of the HOK plan was implemented. The northeast wing was expanded and reconfigured to house a new cafeteria on two levels, the Development Engineering Division, and additional space for design and drafting, metal and carpentry, and shipping and receiving, in the Spring of 1982. A new Etching and Plating building was added to make printed circuit boards. An industrial wing was constructed adjacent to the ETL, the Model Shop building was expanded to the east, and a service court was defined on the east side of the campus, surrounded by Etching and Plating to the west, Shipping and Receiving to the east, and the new wing containing the Development Engineering Division. A 2000 square foot garage and grounds building was placed just outside the loop service road to the southeast.

Despite the fact that Pelli's original scheme for expansion was not implemented, nor was his firm called upon to design the additions, COMSAT Laboratories retains most of the integrity of Pelli's design. During the construction of the "fifth wing," Pelli's horseshoe shaped metal canopy at the south end of the central spine was removed and replaced by a new entrance. The public facades of the building, however—the north and west faces—are essentially unaltered. The west façade of the four-story HOK wing at the southern end of the building is distinct enough as a block that it does not detract from a clear reading of the original Pelli structure.

Exterior Description

Four basic ideas governed Pelli's exterior design for the COMSAT Laboratories. 1) The building was to be a "machine in the garden." 2) It featured a linear composition, with the principal spaces deployed to either side of a central spine. 3) Pelli used glass and aluminum and skin tectonics to produce the distinctive streamlined expression and shape of the complex. 4) All of these elements had practical dimensions but also projected the stated purpose of COMSAT Laboratories: "to be a place where research, experimentation, and construction of telecommunication satellites takes place."¹² The following description will touch on each of these ideas and will focus on the principal facades that give the complex its character: the north and west faces of the building.

¹¹ COMSAT Laboratories, *Clarksburg Construction Program*, Hellmuth, Obata & Kassabaum, P.C., 1980.

¹² Pelli, "Architectural Form and the Tradition of Building," 29.

Maryland Historical Trust Maryland Inventory of Historic Properties Form

Inventory No. MC-13-59

Name
Continuation Sheet

Number 7 Page 5

Linear Composition

In composition, the original COMSAT Laboratories consisted of rectangular masses deployed on either side of a central spine/corridor running north-south. Tightly enclosed in a sleek and apparently seamless glass and aluminum skin, the complex almost seems to hover above the indigenous Maryland countryside. Each mass—four regularly spaced wings to the west and four variously shaped and oriented wings to the east—was topped by a mechanical penthouse. The effect of the complex is of a space-age linear city isolated in a pastoral landscape. The contrast between the structure's mechanistic and forward-looking composition and the unspoiled fields and woods surrounding it was purely intentional. That machine in the garden motif prevailed whether viewing the complex from without or viewing the surrounding countryside through a series of transparent walls and walkways from within.

Construction Methods and Materials

The complex was constructed on “concrete spread footings with steel rigid frame construction in both directions.”¹³ The frame is completely internal, with concrete infill floors of metal decking cantilevering ten feet to the exterior walls.¹⁴ The walls throughout were of a unitized construction based on a five-foot module. The principal elevations were of two types: 1) glass walls separated by thin, bright aluminum mullions for the corridors, lobby, library, cafeteria, rotunda, and northeast elevation, and 2) insulated aluminum panels with punched, rounded windows for the offices. Walls for the service, assembly, and testing spaces on the east side of the complex were of corrugated metal panels.¹⁵

The roof was built up with a vermiculite concrete finish. As the cross-section of the building shows, mechanical services were provided to the laboratory wings through symmetrical vertical shafts between the internal laboratories and the corridors on either side. Because each wing has its own mechanical penthouse, long ductwork runs could be avoided. All laboratories are served by a double duct system and office areas with an induction system and individual automatic temperature controls in each room. The basement area underneath laboratory wing contains equipment for 1,300 tons chiller capacity and 500 HP boiler capacity.¹⁶

Skin Tectonics

On the north and west facades as well as the central spine, western catwalk, and interior court elevations, glass and aluminum wall panels meld to form a tight, flush skin that appears to wrap around the roof and the corners.¹⁷ The effect is airplane-like and it gives COMSAT Laboratories its sleek, futuristic aspect. There are three types of wall and window configurations that need to be described. The more straightforward consists of floor to ceiling glazing in clear glass separated by thin, bright aluminum mullions. The glazing is absolutely flush with the mullions. This treatment—on the northeast wing, exhibit pavilion, and central spine—affords a tremendous transparency offering excellent views to the exterior countryside and the interior courts. At the roofline, a curved aluminum parapet continues the effect of a taut skin wrapping over each element.

The second configuration—which applies to the exteriors and internal court elevations of the four western wings—is more complex. Still in a unitized design of five-foot modules, these walls consist of insulated anodized aluminum panels with smaller “punched”

¹³ Citation, n.p.

¹⁴ Kautz, 8.

¹⁵ Citation, n.p.

¹⁶ “Aluminum Membrane,” 77.

¹⁷ Kousoulas and Kousoulas, *Contemporary Architecture in Washington, D.C.*, 252.

Maryland Historical Trust

Maryland Inventory of Historic Properties Form

Inventory No. MC-13-59

Name

Continuation Sheet

Number 7 Page 6

windows in 5/8 inch bronze tinted solar glass. The windows have curved corners and are set flush on the exterior side into an extruded aluminum sash. The exterior window edges where the sash member is attached to the aluminum panel are sealed by a continuous neoprene gasket.¹⁸ On the office interiors, the openings are set back from a ledge, and resemble airline windows. These flat, glazed modules have been adapted “to accommodate special reinforcing and anchorage.” Since a certain degree of thermal expansion was anticipated, “slotted panel attachment holes in the vertical steel support members provide for this movement.” Each five-foot module is attached vertically, but not horizontally, to its neighboring panel; a special extruded “T” gasket seals the joint, when compressed by the panel installation. “The panels are insulated with glass fiber and internal vapor barrier.”¹⁹ Completing the effect of High-Tech skin, the walls are topped by a curved aluminum faced panel forming a parapet. Behind the parapet, the walls are continuously flashed; the parapet panels are then “set into a continuous aluminum channel.”²⁰

The third window and wall configuration is that of the dramatic western catwalk that stretches from the curved northwest corner of the administrative wing across all three laboratory wings. This is the façade visible from I-270 and responsible for communicating the High-Tech imagery of the complex to the public. The catwalk provides five-foot wide corridors on both the first and second stories that served as a secondary means of circulation (secondary to the central spine) for moving people and materials between the administrative and laboratory wings. Continuing the five-foot modular construction, the catwalk is comprised of two rows of ribbon windows of clear glass separated by thin, flush aluminum mullions divided by a horizontal row of aluminum panels between the stories. The top of the catwalk is crowned by the same curved aluminum parapet found on the other exterior and court facades. Below, however, the catwalk rests on a podium at each wing, but forms a bridge suspended across each courtyard space. This bridge-like effect, with curved aluminum panels reaching from the bottom of the glazing to underneath the catwalk, contributes powerfully to the High-Tech imagery of the complex and especially the sense that the structure is hovering aircraft-like and luminous over the beautiful Maryland countryside. The catwalk closed the courtyards but allowed them to remain visually open to those looking in from outside and to those looking outside from their office windows or from the glazed central spine.

Cesar Pelli was careful to specify materials and construction techniques and fittings for his window/wall configurations in order to maintain a streamlined, futuristic exterior design. To create a skinlike effect, he stipulated the direction and seamlessness of joints as well as the horizontality and continuity of line for each façade. Windows formed continuous bands while the aluminum skin turned over, under and around in a continuous wrapping of complex volumes.²¹ Depending on the angle and the light conditions, one might take in the building as “a single streamlined shape and sometimes like a sequence of courts and wings.”²² The overall effect, however, was clearly a celebration of the promise of technological achievement.²³

Interiors

Visitors not affiliated with COMSAT enter the building by walking past the glazed, cylindrical exhibition pavilion topped by a bold aluminum cornice and connected to the front entry by an aluminum canopy, forming a porte cochère. The interior of the pavilion was used for the display of global communications technology. Inside the main entrance to the complex, the lobby opens up into a two-story space, featuring a dramatic freestanding staircase to the south, fitted with a white metallic tubular railing that curves at the intermediate landing, reminiscent of an ocean liner. The lobby was originally sparsely furnished with modern chairs and tables and

¹⁸ “Aluminum Membrane,” 77.

¹⁹ “Technological Imagery,” 74.

²⁰ Ibid.

²¹ Special Cesar Pelli issue, *A&U*, Tokyo, July 1985, 29.

²² McCoy, “Planned for change.”

²³ Pelli, *A&U*, 29.

Maryland Historical Trust

Maryland Inventory of Historic Properties Form

Inventory No. MC-13-59

Name

Continuation Sheet

Number 7 Page 7

the occasional plant. It contains a painted wall mural (1978) by Terry P. Rogers, which shows COMSAT employees from the late 1970s undertaking the technical work of creating parts for and testing antennae and satellites. Sheer curtains protected the lobby from southern and western light streaming through the floor to ceiling curtain walls. The dominant color was white: white walls and ceiling, white staircase rails, and white 9-inch vinyl asbestos tiles. The lobby had a ceiling of acoustical tiles. Overall, the design effect was High Tech but utilitarian.

The central spine was a glass curtain wall corridor with balconies with railings designed like those in the lobby overlooking the corridor at the second story. The floors were a shiny linoleum. The corridor allowed tremendous views into the courtyards to the west and through the nearly transparent catwalk to the countryside beyond. The most dramatic design element in the glass corridor was a glazed, curved stair tower projecting into the first courtyard. These elements are all intact in the present building.

Wing 0, the first wing to the west, narrower than the other three, houses administrative offices. The principal two spaces of the administrative wing are more richly furnished than any other office spaces in the complex. The main conference room is wood paneled and furnished with high quality wooden office furniture. The overall effect is to produce a men's club-like atmosphere. Secondary and tertiary spaces in this wing are furnished with standard modular office furnishings. In the laboratory wings, the offices lining both the first and second floors were identical cell-like spaces with standard issue office furnishings: desks, chairs, shelves, and filing cabinets.

Of the wings to the east of the central spine, the most dramatic contained the Environmental Test Laboratory. A cavernous space, the ETL contained a roughly three story "high bay" on the eastern side and a lower bay to the west, topped by an enclosed second story balcony for observing activities in the high bay. An industrial space, the ETL contained a rolling crane and a freight elevator.

At the south end of the central spine is the employee entrance to the complex. The original entrance featured a long, horseshoe-shaped canopy ending from the rear entrance, past the end of the ETL wing and out toward the employee parking lot. This canopy is no longer extant.

Maryland Historical Trust

Maryland Inventory of Historic Properties Form

Inventory No. MC-13-59

Name
Continuation Sheet

Number 8 Page 8

SIGNIFICANCE

On September 10, 1969, Comsat Laboratories engineers and scientists were able to move into what was then the world's first research facility dedicated to communications satellite technology. The residents of Clarksburg, Maryland, a small village at the crossroads of the new I-270 highway and Route 121 had witnessed the construction for more than two years of what for many was a Space Age Wonder. Although the list of Comsat Laboratories accomplishments is extensive, the following . . . examples were vital: Comsat Labs personnel designed and flight qualified an experimental re-boost package on a 90-day schedule for installation in the Space Shuttle equipment bay to repair a satellite stranded in low, unusable orbit in 1990. The whole country watched as astronauts recovered the stranded satellite because of the work at Comsat Labs. The Lab personnel also developed the echo canceller, which provided the first commercially acceptable voice service over a satellite circuit. Finally, they developed the nickel hydrogen battery, which doubled the lifetime of satellites, a major economic achievement.

Recollections of Paul Schrantz, Former Vice President, Satellite Systems and Consulting, Comsat Laboratories.

The influences that were most in my mind at that time were not as much architectural, but aircraft construction and esthetics . . . I was pushing the envelope of avant-garde ideas of the moment . . . Perhaps the most significant aspect of this building is that it is now a very early example of high-technology design; an architectural direction that has become very strong, perhaps, dominate, in the last 20 years.

Cesar Pelli, speaking of the COMSAT Laboratories building he designed in 1967.

As stated in the Summary Paragraph of Section 8, the COMSAT Laboratories building in Clarksburg is "exceptionally significant" both from historical and architectural perspectives.²⁴ The fact that it exemplifies the advent of the civilian global communications age makes it exceptionally significant from an historical perspective under the themes of commerce, engineering, science and politics/government. In addition, the distinction of being a very early example of "High-Tech" architecture and a pivotal early work of Cesar Pelli's that went on to influence his future, award-winning work, make the building exceptionally significant from an architectural perspective under the same themes and that of architecture.

Pelli himself noted that the success of the design came despite the incredibly short period of time allotted for its design. COMSAT labs was designed in a month-and-a-half and construction on the building was started only five months after Daniel Mann Johnson and Mendenhall (DMJM, the firm for whom Cesar Pelli worked) was engaged. Specifically, the linear organization of the building reappeared in several later commissions (think of Washington National Airport) as did the "unitized construction" of its walls (i.e., the idea of a repeatable module, which at COMSAT, was five feet).

²⁴ Language from the National Register of Historic Places, Bulletin 15, "How to Nominate Buildings to the National Register of Historic Places," a general model of preservation designation criteria.

Maryland Historical Trust Maryland Inventory of Historic Properties Form

Inventory No. MC-13-59

Name
Continuation Sheet

Number 8 _ Page 9

Montgomery County Master Plan for Historic Preservation Criteria

The building meets many of the criteria for designation of historic structures according to Section 24A-3 of the Montgomery County Code. Specifically, the COMSAT Laboratories building meets the following criteria:

For Historical and Cultural Significance:

1a: Has character, interest or value as part of the development, heritage or cultural characteristics of the county, state or nation

The COMSAT Laboratories building represents the trend toward high-technology innovation in industry in Montgomery County, the nation, and international spheres.

1d: Exemplifies the cultural, economic, social, political or historic heritage of the county and its communities.

The COMSAT Laboratories building represents the advance of the commercial artificial satellite industry throughout the world. This advance was spearheaded, from a research and design perspective, in Montgomery County by the work undertaken at COMSAT Laboratories. The building has political origins tied to the actions of both Presidents Kennedy and Johnson. In addition, it helped define the economic heritage of the County for four decades.

For Architectural and Design Significance:

2a: Embodies the distinctive characteristics of a type, period or method of construction

COMSAT Laboratories represents the International Style in its design esthetic as well as an early example of the "High-Tech" architecture that came to define the corporate "campus."

2b: Represents the work of a master

COMSAT Laboratories is an early design by world-acclaimed architect, Cesar Pelli. He created the design as Director of Design for Daniel, Mann, Johnson, and Mendenhall (DMJM).

2c: Possesses high artistic values

COMSAT Laboratories epitomizes the "machine in the garden" ideal of a futuristic building set within a naturalized setting.

2e: Represents an established and familiar visual feature of the neighborhood, community or county due to its singular physical characteristic or landscape.

COMSAT Laboratories is the most easily identifiable building along the I-270 corridor in Montgomery County. It is the building that represents the fact that Montgomery County is an undisputed leader in high technology industry nationwide.

Maryland Historical Trust Maryland Inventory of Historic Properties Form

Inventory No. MC-13-59

Name

Continuation Sheet

Number 8 Page 10

Though COMSAT Laboratories is admittedly a young resource - not yet 50 years old – the above-stated facts clearly indicate that the building exceeds the minimum requirements for becoming listed on Montgomery County’s Master Plan for Historic Preservation, as well as meets the National Register of Historic Places’ threshold for “exceptional significance” (Criterion Consideration G).

The Trail-Blazing Client: COMSAT and its Laboratories

The Origin of Artificial Commercial Satellites

The idea of artificial commercial satellites emerged with Arthur C. Clarke, a flight lieutenant in the Royal Air Force during World War II. In July 1945, Clarke submitted an article to *Wireless World* titled “The Future of World Communications.” In it, he described the notion of artificial satellites, pointing out that if they orbited the earth at approximately 22,000 miles above the equator, they would take exactly one day to revolve around the earth. This starting point would make them appear to be stationary, or geosynchronous.²⁵ Clarke went on to postulate that these artificial satellites could be ferried to space by rockets. They would function there as manned space stations. Clarke suggested that just three such artificial satellites at specific longitudes could provide the capability for worldwide communication with extremely little power, most of it solar. For his thesis, Clarke received a \$40 payment from the magazine. The irony of this small compensation is that Clarke accurately predicted the advent of the artificial communications satellite system, a billion-dollar industry.

Artificial commercial satellites, which Clarke dubbed “comsats,” were initially developed for the American arsenal of the American-Soviet space race. Thus, comsats were a product of the Cold War. The space race began in earnest on October 4, 1957, when the Soviet Union successfully launched Sputnik I, the first artificial satellite. The United States responded the following year with its own launch of Explorer I, an artificial satellite that led to the discovery of magnetic radiation belts surrounding Earth. Building upon this success, President Eisenhower signed the National Aeronautics and Space Act in 1958, creating a government agency to spearhead these efforts. In 1959, Eisenhower announced:

With regard to communication satellites, I have directed the National Aeronautics and Space Administration to take the lead within the executive branch both to advance the needed research and development and to encourage private industry to apply its resources toward the earliest practicable utilization of space technology for commercial civil communications requirements.²⁶

President Kennedy’s and Johnson’s Contributions

But it was the Kennedy Administration that established the *commercial* satellite industry. In 1961, Kennedy gave a speech to a joint session of Congress outlining a three-point space program that included: 1) landing a man on the moon during the 1960s, 2) developing rocket engines to launch satellites into the outer atmosphere, and 3) creating a global communications satellite system. The latter two points were crystallized with the President’s signing of the Communications Satellite Act on August 31, 1962. After much deliberation, the administration decided that a publicly initiated private corporation would best serve a global communications satellite system. COMSAT, the entity created to develop artificial commercial satellites, became the first privately owned, profit-seeking corporation chartered by Congress. During the years 1961 to 1962, President Kennedy was directly involved in

²⁵ See Michael Tedeschi *Live Via Satellite* by Anthony (Washington, D.C: Acropolis Books, Ltd), 1989. The exact altitude for a three-way, geosynchronous orbit for global communications turned out to be 22,300 miles, a number intentionally used as COMSAT Laboratories’ Clarksburg address. (Comsat is located at 22300 Comsat Drive.)

²⁶ U.S. Department of State, *Department of State Bulletin*, January 16, 1961, p. 77.

Maryland Historical Trust Maryland Inventory of Historic Properties Form

Inventory No. MC-13-59

Name
Continuation Sheet

Number 8 Page 11

the creation of COMSAT. Even prior to the enactment of the 1962 legislation, Kennedy lobbied skeptical members of Congress insisting that global satellite communications would be most achievable through the framework of a privately owned, Congressionally chartered corporation. The President contended that a statute was "required to provide an appropriate mechanism for dealing effectively with this subject – a subject which, by nature, is essentially private enterprise in character but of vital importance to both our national and international interests and policies."²⁷ His brother, attorney general Robert F. Kennedy, also promoted the notion, claiming that the statute authorizing COMSAT was necessary because of the already large public investment in spacecraft and the greater assurance it provided that technology would be shared globally. Attorney General Kennedy summarized COMSAT as playing a "unique and important national role in our overall foreign relations and space effort."²⁸

The 1962 Communications Satellite Act gave the President of the United States the right to continuously review all aspects of the corporation and to "exercise such supervision over relationships of the corporation with foreign governments . . ."²⁹ President Kennedy was directly involved in the selection of several of COMSAT's first executives and board members. President Kennedy named as President his former Under Secretary of the Air Force Dr. Joseph Charyk, and nominated COMSAT's first Board of Directors on October 15, 1962. Directors included heads of large research-oriented companies (such as the President of California's Kaiser Corporation), attorneys, and the Vice-President of United Auto Workers-CIO in Detroit. A close friend, Philip L. Graham, the President of the *Washington Post* media group, acted as chair; in her widely read memoirs, his wife Katherine recalled her husband's involvement with COMSAT at the President's request while Graham was publisher of *The Post*:

In October, Phil took on a job that changed both our lives and sped us up even more. He accepted an invitation from President Kennedy to serve as an incorporator of the Communications Satellite Corporation, known as COMSAT, with the understanding that he would be elected to head it, and in mid-October he was appointed chairman of the group. COMSAT was a groundbreaking public/private organization, half government, half-telephone company. Getting it launched – in essence, translating an exciting vision into a working, financially viable organization – was a full-time job, requiring massive organizational skills, infinite tact and patience, and a huge amount of time and energy. It was not what Phil needed at that time, but it was what he wanted – an irresistible temptation to be engaged in an exciting venture that would, in fact, alter the shape of the world.³⁰

One of the first tasks of the American board members, people like Leo Welch, retired chairman of the Standard Oil Company of New Jersey and Dr. Charyk, was to meet with European and Canadian business and political leaders to hammer out exactly how the new technology could be developed within the framework of a single, international system. The system was put in place to have COMSAT (the United States' agent) and INTELSAT (the international body) as the two primary entities overseeing product development that related to the United States' commercial market. By 1967, INTELSAT would be composed of 58 nations with the U.S.-owned COMSAT owning over 50% of its stock.

Well-known and politically connected people were a part of COMSAT Laboratories from the beginning. Phillip Graham would become a frequent visitor to COMSAT laboratories over the years, along with Barry Goldwater. After Kennedy's assassination, Lyndon Johnson appointed Clark Kerr (a university president), George Meany (union leader) and Frederick Conner (ex-chairman of the board of a major corporation) to the Board of Directors in September 1964. Lyndon Johnson took up the charge of overseeing the global telecommunications industry. On July 23, 1964, COMSAT announced that it would bring live television images of the 1964 Olympics from Tokyo to the United States acting on a request by the State Department. In another significant early advancement,

²⁷ Lloyd D. Musolf, *Uncle Sam's Private, Profitseeking Corporations: COMSAT, Fannie Mae, Amtrak, and Conrail*. Lexington, Mass.: Lexington Books, 1983, p. 18.

²⁸ *Ibid*, p. 23.

²⁹ *Ibid*, p. 20.

³⁰ Katherine Graham, *Personal History* (New York: Vintage Books), 1997, 295.

Maryland Historical Trust

Maryland Inventory of Historic Properties Form

Inventory No. MC-13-59

Name

Continuation Sheet

Number 8 Page 12

President Johnson placed the first formal international commercial telephone call via the Early Bird satellite to political leaders across the Atlantic Ocean on June 28, 1965. Also known as Intelsat I, it established the first transatlantic satellite communications service, since its stationary orbit facilitated its use by stationary ground receivers. Other satellites were in orbit over all parts of the earth, resulting in the global network of satellites, which provided the worldwide coverage of the lunar landing.

A Laboratory Building Tailored to the Satellite Revolution

COMSAT was officially incorporated on February 1, 1963. Its headquarters were initially located at 3100 Macomb Street in Northwest D.C., in "Tregaron," a stately mansion designed by Charles Platt, the architect of the Freer Gallery of Art, whose previous owners included the former ambassador to the Soviet Union, Admiral Joseph Davies and his wife, heiress Marjorie Merriweather Post. In 1964, COMSAT moved its offices from Cleveland Park to a more central location, at 1900 L Street, N.W. The technical staff and satellite control center were located at 2100 L Street, N.W. In June 1968, the headquarters were once again moved, to L'Enfant Plaza. In 1967, COMSAT decided to build separate laboratories and Clarksburg, Maryland, 30-odd miles north of the city, was selected. It would be the laboratories – not the headquarters - that ultimately would symbolize the futuristic nature of the corporation.

COMSAT was responsible for developing a global satellite communications system, the acquisition and maintenance of ground stations around the world, and the development of new satellite technologies. In 1964, the company joined forces with similar organizations in seventeen countries to create the International Telecommunications Satellite Consortium, or Intelsat, in the hope of creating a global commercial communications network. COMSAT established a strong presence in other parts of the United States and in countries throughout the world. By December 1966, its tracking, telemetry and command station at the Paumalu, Hawaii Earth Station entered commercial service. Similar facilities were erected in Etam, West Virginia and Cayey, Puerto Rico (both placed in service in January 1969), as well as in Fucino, Italy; Andover, Maine; Jamesburg, California; and Carnavon, Australia.

By 1967, the "FCC reduced COMSAT's ownership interest in the U.S. stations from 100 percent to 50 percent, with the remaining 50 percent to be divided variously among other U.S. international carriers."³¹ In May 1967, COMSAT "commenced full commercial operations" and realized its first profits by the end of the year.³² By 1970, the Intelsat system provided "much of the world's transoceanic telephone and record communications."³³

The Board recruited the top scientists from around the world to fill key positions at COMSAT Laboratories. A huge proportion of the staff had earned their doctoral degrees in math, engineering, and physics.

From the beginning, COMSAT played a pioneering role in the advancement of the global communications industry.³⁴ The significance of COMSAT Laboratories' contributions to science and technology cannot be overstated. Every single satellite that COMSAT or INTELSAT contracted had, at a minimum, its design reviewed and its components tested at COMSAT. Always focused on research and development for the global communications satellite system, the company awarded the contracts to actually build artificial satellites to allied private companies from the earliest days of the venture. This arrangement proved beneficial to all involved, for AT&T, RCA, Hughes Aircraft (now Boeing) and the like all had huge stakes in the success of the commercial satellite industry. At the company's first stock offering on May 26, 1964, the following "authorized carriers" were allowed to buy stock prior to the June 2nd

³¹ *Comsat at 10*, 18.

³² *Ibid.*, 20-21.

³³ *Comsat at 10*, forward, no. pag.

³⁴ For a thorough history of COMSAT, see Anthony Michael Tedeschi, *Live, Via Satellite: The Story of COMSAT and the Technology that Changed World Communication*, Washington, D.C.: Acropolis Books, Ltd., 1989.

Maryland Historical Trust Maryland Inventory of Historic Properties Form

Inventory No. MC-13-59

Name
Continuation Sheet

Number 8 Page 13

public offering: AT&T, International Telephone & Telegraph, RCA-Communications, Press Wireless (owned by the New York Times, New York Herald-Tribune and Time, Inc.), and General Telephone & Electronics. News reports indicate that by June 2nd, the company had "attracted so much publicity, glamour and general awe that several thousand people rushed to their brokers clamoring for the stock."³⁵

COMSAT had multiple, well-organized divisions that focused on satellite design and testing. COMSAT Laboratories was responsible for transmission system design and analysis, interference analysis, system architecture development, system design evaluation, traffic and protocol modeling, network simulation, terrestrial user interfaces, and specification development. In sum, COMSAT Laboratories undertook every aspect relating to satellite design short of physically building the satellite. COMSAT's early goals were to develop high-orbit and medium-orbit artificial satellites. For the latter, COMSAT worked with AT&T, RCA, Thompson Ramo Wooldridge and ITT.

The first contract to build an experimental-operational synchronous satellite for high altitude was let by COMSAT in the spring of 1965 to Hughes Aircraft. The resulting first commercial satellite in geosynchronous orbit designed specifically for commercial use was dubbed the "Early Bird" (later known as Intelsat I). This high-orbit satellite had the capacity to provide up to 240 high-quality telephone voice circuits or black-and-white television, facsimile, and other types of messaging. The impact of the Early Bird's capacity to project live television images from around the world to Americans in their homes was enormous. On May 3, 1965, The Today Show became one of the first television shows in history to broadcast images live from the Hague, Brussels, Paris, Rome, and London via the Early Bird satellite. Because of its incredibly ambitious and successful program, the Early Bird's launch on April 6, 1965 established COMSAT as the world leader in global satellite telecommunications. Following the Early Bird there was the Lani Bird, which provided telephone circuits between the United States and Hawaii and was successfully launched in early 1967 (dubbed Intelsat II).

COMSAT needed a building for the research, development, and production of communications satellites. This program raised many challenges. The spaces had to fulfill highly specialized functions, but had to adapt to new technologies. Furthermore, the entire structure had to be able to be expanded easily to accommodate future functions. The frenetic pace of the space race required all plans to be prepared in five months. The design phase lasted only one month, with the remaining four months devoted to the preparation of construction documents. The \$7.8 million budget was also fairly limited, requiring a simple, functional design. The structure was completed on time and within the budget, the original building costing \$ 9,257,793, including lab equipment.³⁶

COMSAT's satellites continued to make television images available to viewers from the far reaches of the globe. By 1969, COMSAT's research and testing work was all being done out of its new Clarksburg facility, which had been built to house 300 employees in 250,000 square feet of space. On July 20, 1969, both COMSAT and INTELSAT broadcast the televised image and voice of Neil Armstrong as he took his famous strides on the surface of the moon. Successes like these resulted in COMSAT's receiving an Emmy award for significant achievement in television research and development.

A continuing avenue of research for COMSAT Laboratories was the refinement of ground earth stations, or antennae, to increasingly smaller sizes. The company developed not only satellite dishes that could be stowed away in suitcases, but also flat plate antennae that could be mounted on walls or patios. COMSAT also refined the capability of one antenna to simultaneously access multiple satellite transmissions. The Torus Antenna, located today on the east lawn of COMSAT Laboratories, is an example of such an antenna.

³⁵ "Stock of Satellite Corporation Stuns Experts with Sharp Rise," *New York Times* (August 7, 1964), p. 33.

³⁶ "Imagery," 71.

Maryland Historical Trust

Maryland Inventory of Historic Properties Form

Inventory No. MC-13-59

Name
Continuation Sheet

Number 8 Page 14

COMSAT Laboratories also had an entire department devoted to the creation of antennae, or satellite dishes, for space, ground and mobile applications. The mobile satellite dishes created for these purposes provide clear communications between ships to each other and ships to shore, not only for the defense industry, but also for maritime and luxury cruise industries. The most famous sea-related COMSAT satellite user was Jacques Cousteau, who used the company's products on his ship, the *Calypso*, in 1975-76 and came to Clarksburg to speak before COMSAT's employees.

Other signature innovations developed by COMSAT Laboratories include: videoconferencing, direct TV, the echo suppressor and echo canceller, and the hydrogen-nickel oxide battery that extended satellite battery operating power enormously. In 1997, COMSAT Laboratories was inducted into NASA's Space Technology Hall of Fame for its Advanced Communications Technology Satellite (ACTS) program. The Laboratories hold over 100 patents and have an additional 70 or so that have been filed. These patents cover the following technologies: asynchronous transfer mode (ATM), Frame Relay, and Internet Protocol (IP) via satellite; modem, coding, and encryption; voice and video encoding; flat plate and phased-array antennas; microwave filters and components; space-qualified batteries; multiple-access techniques and synchronization; C, X, and KU-band active phased arrays for reconfigurable multiple-beam satellites; and onboard digital signal processing. The Hubble space shuttle batteries were developed and tested at COMSAT and spacecraft that encounter problems were diagnosed at COMSAT via Destructive Physical Analysis, or DPA.

The significance of the Laboratories' contributions to global communications is enormous. As an indicator of the company's impact, the Library of Congress, Motion Picture Division, will be accessioning the company's video stockpiles to its archives after transferring them to film. The Smithsonian's Air and Space Museum also has expressed interest in an exhibit on the company's achievements.

COMSAT Laboratories as Harbinger of Development along the Interstate-270 Corridor

On the last day of 1973, the front page of the *Washington Post* featured an article entitled "I-70S: How Cow Country became Corridor City." The introduction read as follows:

In the late 1940s, Maryland State Roads Commission engineers drew a line on a Montgomery County map with a new high-speed road nearly 23 miles long between North Bethesda and the Frederick County border. The land on either side of that line was then mostly a rural expanse of dairy farms broken only by a few relatively small towns like Rockville, Gaithersburg and Germantown. The strip of Montgomery County is much different today. In the more than two decades since state road engineers designated the path of their new highway - now Interstate 70 S, six lanes wide in some places - it has become the backbone of a bustling corridor city of some 130,000 residents, plus 720 private businesses and nine federal agencies with 37,800 jobs. Where cow had grazed and barns had dotted the countryside, there are now corporate offices for firms like IBM and Comsat and sprawling federal campuses for agencies like the National Bureau of Standards and the Atomic Energy Commission.³⁷

COMSAT Laboratories, located at the northernmost section of the "corridor city," was a major benchmark in changing the face of upper Montgomery County. And as Montgomery County stepped into the twenty-first century, the "High Technology Corridor," the beginnings of which are discussed next, "housed more than 500 major companies, rivaling California's Silicon Valley and Boston's Route 128 in many ways."³⁸

³⁷ Kenneth Bredemeier, "I-70S: How Cow Country became Corridor City," *Washington Post*, December 31, 1973, A1.

³⁸ Jane Sween and William Offutt, *Montgomery County: Centuries of Change*, Sun Valley, California: American Historical Press, 1999, 142. Among companies which moved to the corridor after COMSAT, the authors mention the Marriott Corporation, the Food

Maryland Historical Trust Maryland Inventory of Historic Properties Form

Inventory No. MC-13-59

Name
Continuation Sheet

Number 8 Page 15

Before it was relocated and widened (in five stages, in a southerly direction, from 1953 to 1960), U.S Route 240, from Frederick to Washington, was known as the Washington National Pike; in 1959, it was renamed Interstate 70-S. The I-70 S (now Interstate 270) corridor was designed to link Frederick in a *southerly* direction with Rockville, but quickly emerged as a way for Washington government and industry to move *northward* from the capital. Its unique strategic location was reinforced with the completion of the Beltway (I-495) in 1964.³⁹

The idea of radial growth corridors for the Capital Region, separated by wedges of low density housing and open space, was expounded in the 1961 *Policies Plan for the Year 2000* prepared by the National Capital Planning Commission and National Capital Regional Planning Council. This diagrammatic proposal focused on European-style "finger plan" growth, with radial corridors of new town centers separated by undeveloped natural wedges and low density housing, was only partially implemented, and at a much reduced scale. It nonetheless informed development along I-70S.

However, Cold War policies seem to have played a more significant role in shaping the I-270 corridor than utopian planning diagrams. With the notion that a single nuclear bomb could devastate central Washington, D.C., the United States government began spreading out its agency headquarters as early as 1945. The construction of the Naval Surface Warfare Center at White Oak in Silver Spring in the eastern part of the county signaled the first of these Cold War moves. Erected for the most part before 1954, the White Oak complex employed some of the world's top scientists and was located not only for its convenient distance from the capital, but because the partially wooded site provided uniform magnetic fields.

Over the course of the next ten years, upper Montgomery County - less populated and more affordable than the Bethesda-Silver Spring-Wheaton areas - would become a highly desirable location for high-technology government agencies with either or both an interest in a campus setting and a preference for headquarters close to, but outside of the city's core. In November 1957, President Eisenhower dedicated a new \$13.3 million headquarters for the new Atomic Energy Department at Germantown near the interchange between State Route 118 (Germantown Road) and Route 240. The agency, which counted 1600 employees at the time, was responsible for all aspects of nuclear research, both for weaponry and civilian industries.

The buzz around AEC's move to "cow country" triggered, and necessitated, new zoning and planning strategies, as well as provision for new sewers and public schools. In 1956-57, the County Council commissioned to Planning Consultant Dorothy A. Muncy, Ph.D., a report listing sites ranging from 100 to 300 acres that would be appropriate for "prestige" industrial compounds scattered in upper Montgomery County. Among the sites meeting "the requirements of terrain, access to transportation and to existing and planned public utilities," two were located at the Clarksburg interchange, where COMSAT would elect to build its headquarters a decade later.⁴⁰ At the request of the County Council, Hugh Pomeroy, the planning director for Westchester County, N.Y., issued a guide for a 52-square mile area north of Rockville, embracing Germantown and Gaithersburg. Pomeroy's report also called for "designated sites for possible industries" and "extensive lands for public recreation."⁴¹

and Drug Administration, NOAA, the Nuclear Regulatory Commission and Computer Data Systems. An earlier, albeit far less spectacular, High-Tech concentration in the state of Maryland can be found in Howard County's tiny town of Clarksville, located approximately half-way between Baltimore and Washington and easily accessible from route 29. It is where Johns Hopkins University moved its Applied Physics Laboratory (engaged in guided missile research) in 1954, designed by Voorhees, Walker, Smith and Smith and expanded five years later. In 1958, using the same architects and a nearby location, W.R. Grace & Company (based in Florida) opened a 96,000 square-foot industrial chemical research center, consisting of laboratory buildings and supporting facilities.

³⁹ In the early 1960s, projects to continue I-70S beyond the Capital Beltway (I-495) toward the District of Columbia were banned by

Congress.

⁴⁰ Jeff O'Neill, "'Prestige' Industry Zone Urged," *Washington Post*, November 27, 1957, A 11.

⁴¹ "County Growth Guide Offered," *Washington Post*, May 29, 1957, B4.

Maryland Historical Trust

Maryland Inventory of Historic Properties Form

Inventory No. MC-13-59

Name
Continuation Sheet

Number 8 Page 16

In July 1956, the National Bureau of Standards (presently National Institute of Standards and Technology) purchased a large tract of land four miles south of AEC, close to the interchange between Routes 240 and 124 (presently Quince Orchard Road), just south of what was then the Gaithersburg town boundary. In early 1957, the General Service Administration announced that plans for new office and research facilities had been entrusted to Voorhees, Walker, Smith and Smith, a "firm specializing in large research centers."⁴²

In the word of its director, Dr. Allen V. Astin, NBS was moving away from its once pastoral site on Connecticut Avenue and Van Ness Street in the District of Columbia "for the same reason our predecessors chose the present headquarters in 1901 - a rural area that's accessible to the city." NBS' second in command added: "We must be in an area that's reasonably free from industry ... as smoke, noise and vibration would affect seriously the precise weights and standard measurements we must make."⁴³ Construction started in 1959, first with the nuclear radiation facility and second with laboratories to measure the weight and thrust of U.S. satellites. From 1963 to 1967, NBS gradually moved into its new 550-acre campus, which cost tax payers \$ 115 million. Its presence was undoubtedly an incentive for COMSAT's purchase of acreage a few miles further north.

Slightly further south of NBS, development started at the crossing of Shady Grove Road and I-70s in the late 1950s and became the talk of the town when developer Sam Eig decided to erect a 26-story apartment tower amidst the links of the Washingtonian Golf Course. Designed by Loewer Sargent and Associates and completed in 1966, the Washingtonian Towers (a second identical structure was planned but not built) followed the model of the "tower in the park" dear to Le Corbusier, the modernist master architect. It served as a stunning (albeit architecturally unremarkable) vertical marker for sprawling low-rise commercial and corporate structures clustering on the Gaithersburg section of the I-70S corridor. In addition to the Bureau of Standards, Eig's tower was near the office building (designed by Curtis & Davis, in association with Donald B. Coupard), which the International Business Machines Corporation opened in 1966, to "unite about 1200 IBM employees scattered at nine leased sites in Rockville and Bethesda."⁴⁴ The Washington Towers was also in close proximity to sites recently purchased by the Bechtel Corporation and Eastman Kodak.⁴⁵ In 1968, while COMSAT was under construction, IBM announced the erection of an even larger adjacent office structure, designed by the Architects Collaborative, the Boston firm founded by modernist master Walter Gropius. Despite the fact it had been designed by two firms with a distinguished track record, the resulting opaque and formless compound offered none of the elegance and excitement provided by Cesar Pelli's design for COMSAT Laboratories.⁴⁶

Prior to the erection of COMSAT Laboratories, there was only one significant industrial and corporate compound located north of the Atomic Energy Commission site. It was built for Fairchild Industries (or Fairchild-Hiller) in Germantown. While Fairchild was in the business of airplane manufacturing and, later, satellite and related electronics work, it is COMSAT Laboratories that holds the distinction of being the first private building on the corridor to use a completely High-Tech esthetic for its architecture. Fairchild's is an industrial plant largely devoid of exterior architectural interest. It consists of a pod-like development of four buildings on the west side of I-270, anchored by two surface parking lots and a private short takeoff & landing (STOL) runway of 600 feet. Unlike COMSAT, which is light and airy, the square Fairchild buildings are low to the ground and opaque.

⁴² "GSA Names Designers for Standards Center," *Washington Post*, January 25, 1957, B4.

⁴³ Herry Kluttz, "Bureau of Standards Is Going Back to Its Pastured Peace of Early Days," *Washington Post*, November 30, 1958.

⁴⁴ "Plans Set for IBM Gaithersburg Unit," *Washington Post*, May 31, 1965, D10. IBM purchased the site in 1962.

⁴⁵ John B. Willmann, "Sam Eig Hits New Peak In Apartment Living," *Washington Post*, April 2, 1966, F7. the full-scale implementation of Washingtonian Center - a mixed-use development - was undertaken in the 1980s and 1990s.

⁴⁶ "New Area IBM Facility to Employ 1200," *Washington Post*, June 6, 1968, C8.

Maryland Historical Trust Maryland Inventory of Historic Properties Form

Inventory No. MC-13-59

Name
Continuation Sheet

Number 8 Page 17

When COMSAT moved to Clarksburg, this unincorporated community had less than 2,000 residents and zoning prescribed minimal residential lots of two acres. In 1967, a preliminary master plan prepared for M-NCPPC by Marcou, O'Leary and Associates called for "industrial strip development along 70S, small lot subdivision zoning and garden apartments and town houses. Public Park space is to be provided by the projected Little Seneca Regional Park which takes the southern end of the planning area." Additionally the plan recommended the widening of I-70S to six lanes and the construction of "rapid transit lines at least as far as Germantown."⁴⁷ Adopted in the 1968, the *Clarksburg and Vicinity Master Plan* was more realistic: it was meant to guide Clarksburg's growth "from its present rural character to a small town rather than a Corridor City." In fact, land use recommendations in the 1968 Master Plan were not fully realized because "public policy discouraged the extension of public water and sewer service ... in order to encourage development south of Clarksburg, in Germantown or Gaithersburg." Many zoning changes were not adopted, and the new master plan of 1994 is striving to preserve a "town scale of development" as well as farmland and historic resources.⁴⁸

Suburban and Exurban Corporate Design in the United States

Pelli's Comsat stands squarely in the camp of outstanding research commissions undertaken by master architects of the Modern Movement. Architects approached these projects in a manner of ways, depending upon the program. If laboratories were located in the same compound as head offices, they could be fairly lavish and spectacular. A case in point is the research tower (1945-1949) Frank Lloyd Wright designed adjacent to the Johnson Wax Administration Building (1936-39) in Racine, Wisconsin. If erected separately, laboratories were generally built economically and adopted streamlined, mechanical forms; however, both corporate clients and designers were aware that highly qualified lab workers demanded pleasant and hospitable surroundings and decent services, such as a well-lit cafeteria. After World War II, companies involved with state-of-the-art technology started to establish office and research centers in the far suburbs or the countryside. Decentralization was dictated by security reasons; to minimize land cost; and for the benefits of employees, who enjoyed restful surroundings and worked close to their suburban homes.

Eero Saarinen, Cesar Pelli's long-time employer, played a considerable role in giving form to the corporate and research campus. Monumental and dignified, a Versailles for high technology, his General Motors Technical Center in Warren, Michigan (1948-56) is an epochal work, which inspired many laboratory designers to group rectangular wings along open landscaped courtyards, to use angular profiles and crisp detailing in metal and glass. It included a glazed elevated breezeway, which anticipated COMSAT's catwalks.⁴⁹ At GM, Saarinen used a standard module for all the buildings, and "embraced a new thin-skin technology based on manufacturing techniques. Technical innovations included development of a thin, porcelain-faced sandwich panel serving as both exterior skin and interior finish ... and the use of neoprene gaskets for all window glazing, modeled on the system used for the installation of car windscreens."⁵⁰

An elegant interpretation of the GM model was IBM's Engineering & Development Laboratory in Poughkeepsie, N.Y., designed by Elliott Noyes and Associates and completed in 1956: it featured a two-story glass bridge connecting the wings.⁵¹ Another is the research lab and office building designed by Skidmore, Owings and Merrill for Wyeth in Radnor, PA.⁵² The Thomas J. Watson Research Center (1956-61), which Saarinen designed for IBM in Yorktown Heights, N.Y., was a crescent-shaped structure - one side

⁴⁷ Thomas W. Lippman, "Clarksburg Seen Housing 75,000 Residents in Future", *Washington Post*, June 1, 1967, E 4.

⁴⁸ Maryland-National Capital Park and Planning Commission, *Approved and Adopted Clarksburg Master Plan & Hyattstown Special Study Area*, 1994.

⁴⁹ Reproduced in Allan Temko, *Eero Saarinen*, New York: Braziller, 1962, p. 19, fig.24.

⁵⁰ Peter Papademitriou, 'Saarinen, Eero', *The Grove Dictionary of Art Online*, (Oxford University Press,

Accessed 25 October 2004), <<http://www.groveart.com>>

⁵¹ See *Architectural Forum*, February 1957, 111.

Maryland Historical Trust

Maryland Inventory of Historic Properties Form

Inventory No. MC-13-59

Name

Continuation Sheet

Number 8 Page 18

entirely glazed, the other principally of stone - where circulation was rejected at the periphery. Although this extraordinary "machine in the garden" was not a direct inspiration for COMSAT Laboratories, it certainly emboldened Cesar Pelli to leave the beaten paths of laboratory design. One new direction he decided not to take was the "fortress look" adopted by some companies, out of programmatic or functional necessity or for budgetary or aesthetic reasons. Opaque, "brutalist" exteriors were rarely pleasing to the eye; one exception was Philadelphia architect Vincent Kling's award-winning Molecular Electronic Division for Westinghouse Electric Corporation, located in Maryland's Anne Arundel County, within view of the Baltimore-Washington Parkway.⁵³

The Designer, Cesar Pelli, and his Associates

For its new laboratories, COMSAT hired Daniel, Mann, Jackson, Mendenhall (thereafter referred to as DMJM) headquartered in Los-Angeles, in great part because of the familiarity of this large architecture and engineering (A/E) firm with space race-related programs and its excellent track record in project management. COMSAT also gained the services of a uniquely cosmopolitan and gifted architect, in the person of DMJM's Director of Design for domestic operations, Cesar Pelli.⁵⁴

Cesar Pelli was born in San Miguel de Tucuman, Argentina, in 1926 and earned a Diploma of Architecture from the National University of Tucuman in 1949, where his schooling was influenced by the teachings of the French architect Le Corbusier and the Congrès Internationaux d'Architecture Moderne (CIAM).⁵⁵ The following year, while in the employ of a government organization, he married Diana Balmori, a landscape architect who has achieved professional prominence in the United States. In the late 1940s, Argentina boasted a sizable number of progressive and talented architects, aware of the pitfalls of functionalism and yearning for a more humanistic and contextual form of modernism. Pelli stressed that he enjoyed the "great intellectual effervescence" surrounding his studies.⁵⁶ In the *Contemporary Architects* encyclopedia, Pelli acknowledges to have been influenced several of his professors: Jorge Vivanco (1912-1990, a member of the avant-garde Grupo Austral), Eduardo Sacriste (1905), who was the leading modernist figure in Tucuman, and the renown Italian architect Ernesto Rogers (1909-69 BBPR).⁵⁷

In 1952, Cesar Pelli moved to the United States to study at the University of Illinois at Urbana-Champaign, from which he received a Master of Science degree in Architecture two years later. Upon graduation, he found employment as Associate Architect for Eero Saarinen and Associates, one of the country's most prestigious firms, based in Bloomfield Hills, Michigan. Pelli acted as project designer for two masterworks: the TWA Terminal (1956-62) at Idlewild (now John F. Kennedy) Airport, New York, and for the Samuel B. Morse and Ezra Stiles colleges (1958-62) at Yale University. The two designs have apparently little in common, the "expressionist" airport building reminiscent of a bird in flight; the dormitories evoking "the image of a medieval community of scholars."⁵⁸ Working for such a protean employer, Pelli learned how to be both demanding and pragmatic:

Never directly committed to the International Style, Saarinen's systematic, almost engineer-like insistence on analyzing the nature of a project suggested the possibility of an autonomous architecture for each building, a concept of "the Style for the

⁵² See *Buildings for Research*, New York City: F.W.Dodge Corporation, 1958, 105-110.

⁵³ "Miniature Circuits," *Progressive Architecture*, November 1964, 158-161. See also "Turreted Modules for Ultra-fine Manufacturing," *Architectural Record*, July 1964, 165. The design received an Award of Merit from the Baltimore Association of Commerce and Baltimore Chapter of the AIA.

⁵⁴ DMJM also had a Director of Engineering.

⁵⁵ Cesar Pelli, "Transparency - Physical and Perceptual," *A+U* 71 (November 1976), 77

⁵⁶ Pelli interviewed by Michael Crosbie, in *Cesar Pelli: selected and current works* Mulgrave, Victoria: Images Pub. Group, 1993, 7.

⁵⁷ Muriel Emanuel, ed., *Contemporary Architects*, New York: St. Martin's Press, 1980, 613.

⁵⁸ Peter Papademitriou, 'Saarinen, Eero'

Maryland Historical Trust Maryland Inventory of Historic Properties Form

Inventory No. MC-13-59

Name
Continuation Sheet

Number 8 Page 19

Job". He sought to direct contemporary technology in diverse architectural expressions to the advancement of the symbolic and environmental content of that tradition through the exploration of special architectural vernaculars for each project.⁵⁹

In 1961, Saarinen died unexpectedly and Kevin Roche, a longtime employee, took charge of the office, which was named after him five years later. Cesar Pelli realized it was time "to make his own architectural decisions."⁶⁰ In 1964, he moved to Los Angeles to become Director of Design at DMJM, in the company of another former Saarinen employee, Anthony Lumsden, who was born and trained in Australia and became his assistant. The pace at which essentially utilitarian projects needed to be delivered was dramatically faster than for Saarinen's prestige commissions, and construction budgets were far less generous, but Pelli rose to the challenge and enjoyed having so many in-house services, and a close relationship with DMJM's engineering department.

DMJM finds its origins in 1945, when architects Philip Daniel, a graduate of the University of Southern California, and Arthur Mann, trained at the Beaux-Arts Institute of Design and the Chouinard Art School, established an office in Santa Maria, California. They were soon joined by S. Kenneth Johnson, another USC architecture graduate. In 1947, sensing major opportunities for work in this city, the young firm moved to Los Angeles, as did one of their professional acquaintances, civil engineer and UC-Berkeley graduate Irvan Mendenhall. The Daniel, Mann & Jackson firm officially merged with that of Mendenhall in 1949.

In its first years, DMJM produced its share of public schools, necessitated by Southern California's migratory and baby boom: grouping elementary, junior and senior high schools, the sprawling plant for Culver City, illustrated by *Architectural Record* in November 1951, as well as the Seaside School in Torrance, published by *Progressive Architecture* in September 1952, demonstrate a good command of the modernist syntax. However, the multi-disciplinary A/E firm had greater ambitions and began attracting a variety of significant public and corporate clients. DMJM specialized in large scale construction, as evidenced by its "Wonder Palace" convention center in Anaheim.

DMJM's involvement with space age activities started in 1954, with the construction, in Santa Susana, Calif., of a rocket engine test stand for the U.S. Atomic Energy Commission. On the same site, the firm also built an atomic accelerator and facilities for the storage and disposal of radioactive waste. In 1958, DMJM (in joint venture with The Rust Engineering Co., Leo A. Daly Co., Architects and Engineers and Hanger-Silas Mason Co., Inc., engineers and Contractors) was asked to establish "design criteria for all U.S. training and operational bases for the Titan I missile program."⁶¹ DMJM designed several launch pads, including at Cape Canaveral, as well as the Donald W. Douglas Engineering Development Center in Huntington Beach, a compound of nine buildings on 245 acres built for the Missile and Space Systems Division of the Douglas Aircraft Company.⁶²

As "DMJM became more and more involved in the design of missile bases, it became apparent to the firm that it needed to provide itself with capabilities for research and development work in the fields of the missile themselves, and the related sciences." It decided to acquire an existing company, Systems Laboratories, Inc., which performed "research, consulting work, and development work in aeronautics, nucleonics, missile systems, automatic control and computer systems, physics, chemistry, mathematics, and similar fields." Other major commissions included master plans for several U.S. Air Force bases, urban renewal proposals for several cities in California (including Santa Monica and Sacramento) and a flood and water supply study on behalf of the Southern California Rapid Transit District. DMJM was also involved in the design of zoological parks, including the Great Flight Cage at the National Zoo in

⁵⁹ Ibid.

⁶⁰ Cesar Pelli, quoted in Esther McCoy, "Reflections on Cesar Pelli," *A+U*, July 1985, 15.

⁶¹ Clinton A. Page, "Names [The firm of Daniel, Mann, Johnson and Mendenhall] *Architecture and Engineering Record* 9 (June 1967), 104.

⁶² "Space Industries' Demanding Criteria," *Architectural Record* (July 1964), 169.

Maryland Historical Trust

Maryland Inventory of Historic Properties Form

Inventory No. MC-13-59

Name

Continuation Sheet

Number 8 Page 20

Washington, D.C. In addition, many commissions for corporate offices and public works (road or flood control) went its way.⁶³ In 1960, as DMJM had “performed professional services for well over \$ 2 billion of construction,” the partnership was transformed into a corporation, which extended its reach to industrial engineering (statistics, electronics) and real estate activities.⁶⁴ By the time the COMSAT commission was under construction, DMJM had offices in Washington, D.C, San Francisco, Portland, Las Vegas, as well as in Hawaii, Venezuela, Vietnam, England, Thailand and Indonesia.

Before hiring Pelli and Lumsden, DMJM’s reputation was based less on design excellence than on the diversity and quality of its services. Pelli’s designs earned DMJM many accolades from the architectural press and profession. In 1966, the “megastructural” Urban Nucleus for Sunset Mountain Park in Santa Monica (commissioned by the Sunset International Petroleum Corporation, but never built) received a First Design Award from the magazine *Progressive Architecture* - the highest distinction granted in this prestigious, peer-reviewed competition and the only award of this kind given that year. The city’s spectacular renderings found their way (with a very positive description) in the prestigious French journal *L’Architecture d’Aujourd’hui* in 1967. *Progressive Architecture* also published Pelli’s and Lumsden’s colorful and glamorous vaulted interiors for the Jewelers Center on Beverly Hills’ Wiltshire Boulevard, Pelli’s powerful entrance for the Third Street Bunker Hill Tunnel, and the Worldway Postal Center at Los Angeles International Airport, completed in late 1968 (this project received an Honor Award from AIA Southern California). The well respected Italian magazines *Lotus* and *Domus* also published Pelli’s work for DMJM, as it was akin to that of young European architects they championed: issues illustrating his designs also showed work by Renzo Piano or Richard Rogers, who were to achieve international fame with their winning design for the Centre Georges Pompidou in Paris.

In the manufacturing and research facility for Teledyne Systems Co., erected in Northridge, in California’s San Fernando Valley, and completed in 1967, Pelli “rehearsed” his design for COMSAT Laboratories. The Teledyne lab was reviewed by the noted California critic Esther McCoy in the July-August 1968 issue of *Architectural Forum*. McCoy praised Pelli’s “controlling hand” which insured aesthetic success despite successive cost trimmings. Located in an agricultural setting (a 36-acre citrus grove, which Pelli was able to safeguard almost completely) along a highway, the structure comprised 165,000 square feet of offices and assembly labs for microelectronics elements, and was built at a cost of \$ 2,850,000, including landscaping. The plan was controlled by a circulation spine, a wide corridor acting as informal meeting space, which was lined with continuous reflective glass on one side; as many of Teledyne’s activities were classified, the workspaces were lit indirectly with interior corridor windows. In this project, Pelli began exploring ideas of spatial flexibility inherent to the electronic industry. McCoy quoted Pelli:

It is seldom possible to predetermine growth, and the problem is how to plan for undetermined growth without throwing the architecture away.

McCoy rightly perceived the lineage between ideals of pioneering modernists - such as the German architect Walter Gropius at the Fagus Factory (1911-12) in Alfeld an der Leine and Bauhaus buildings (1925-26) in Dessau - and Pelli’s concern “with the development of tools for flexible solutions for the present,” his differentiation between skin and support, his use of standardized parts. This philosophy and the idea of building a “complex” as opposed to a “building,” Pelli confided to McCoy, was foreign to many of his U.S. colleagues. McCoy’s article concluded: “Commonsense architecture is lifted above dullness and it becomes the means through which the city is refreshed.”⁶⁵ In 1968, Teledyne Systems Laboratories received an Honor Award from the American Institute of Steel Construction.

⁶³ In 1969, DMJM prepared a study for an industrial airpark sponsored by the Commissioners of Prince George’s County. See Lawrence Meyer, “Bowie Airpark Cost Pur at \$ 58 Million,” *Washington Post*, November 7, 1969, B4.

⁶⁴ “Office organization and procedures for present-day practice: organization for efficient practice 2: Daniel, Mann, Johnson and Mendenhall, archts. & engrs.,” *Architectural Record* 127 (June 1960), 190.

⁶⁵ Esther McCoy, “Planned for Change: Cesar Pelli Designs an Adaptable Electronics Plant,” *Architectural Forum* 129 (July-August 1968), 102-107.

Maryland Historical Trust Maryland Inventory of Historic Properties Form

Inventory No. MC-13-59

Name
Continuation Sheet

Number 8 Page 21

In 1969, while COMSAT Laboratories were nearing completion, Cesar Pelli left DMJM to become partner in charge of design at Victor Gruen Associates, a Los Angeles firm internationally known for its pioneering work in shopping center design.⁶⁶ That same year, he won the International Architectural Competition for the United Nations City in Vienna, Austria (unbuilt). In his designs for the San Bernardino City Hall (1969-72) the Columbus Commons (1970-73), the US Embassy office in Tokyo (1970-75), and the Pacific Design Center in Los Angeles (1975, nicknamed the Blue Whale), Cesar Pelli perfected his "investigation of the gestural and sculptural possibilities of the cladding, particularly the nature of glass as a transparent and reflective material."⁶⁷

In 1977, Cesar Pelli moved East to become Dean of the School of Architecture at Yale University, a coveted academic position he held until 1984. At the same time he launched his own practice in New Haven. Very large and prestigious commissions went his way at an increasingly faster pace, marking the skyline of major cities the world over: in New York City, the Museum of Modern Art extension and residential tower (1978-84), and the World Financial Center and Winter Garden (1982-87); in Charlotte, N.C., the Bank of America Corporate Center; in Minneapolis, the Wells Fargo (formerly Norwest) Center; in London's Canary Wharf district, One Canada Square (completed 1991), Britain's tallest building at the time of its construction; in the Hague, Netherlands, the Zurich Tower; in Tokyo, headquarters for NTT Shinjuku (1990-95) and the Mori Tower; in Osaka, the NHK Osaka Headquarters and Broadcast Center; in Hong Kong, the Cheung Kong Center; in Buenos Aires, the Edificio República (1993-96) and BankBoston Argentina Headquarters; and in Kuala Lumpur, the twin 1483-foot high Petronas Towers, the world's tallest buildings at the time of their completion in 1997.

Pelli's firm received many commissions for healthcare and research facilities, such as the Lerner Research Institute in Cleveland and Yale University's Boyer Center for Molecular Medicine; and for departments of physics, astronomy, mathematics, engineering and computing sciences at the Institute for Advanced Study in Princeton (1989-93), the University of Washington-Seattle (1989-94), Trinity College in Hartford, CT and the University of Houston. A recent area of expertise has been performing arts centers. Several master plans - for Bilbao, Fukuoka in Japan and Cordoba in Argentina - have also come Cesar Pelli's way. A crowning achievement of his firm has been the Washington National Airport (1990-97).

Cesar Pelli's firm was the recipient of many professional awards, including the extremely prestigious firm award from the American Institute of Architects in 1989.⁶⁸ As an individual, he was awarded the Arnold Brunner Memorial Prize from the National Institute of Art and Letters in 1978 and was elected Associate of the National Academy of Design in 1978. Receiving the Gold Medal of the American Institute of Architects in 1995 placed Cesar Pelli at the very top of his profession. In 2001-2002, his work was the subject of an extensive retrospective exhibition organized by the National Building Museum in Washington, D.C.

Other persons associated with the design and construction of COMSAT laboratories were DMJM's S. Kenneth Johnson (Partner-in-Charge) and Philo Jacobsen (Design Associate). The general contractor was J.W. Bateson (presently Centex Bateson Construction Company, Inc.) based in Dallas, which had already built a large section of the National Bureau of Standards between

⁶⁵ Esther McCoy, "Planned for Change: Cesar Pelli Designs an Adaptable Electronics Plant," *Architectural Forum* 129 (July-August 1968), 102-107.

⁶⁶ At DMJM, Pelli's position was filled for the next 25 years by Lumsden, who brought to completion the Federal Aviation Agency Building, initially planned by Pelli, a radical exercise in "light weight sculptural surface" in reflective glass and aluminum, "where the building goes over the top, the building comes under the bottom, and also goes around the corner" (Lumsden, quoted in Ross, "The Development of an Esthetic System at DMJM," *Architectural Record*, May 1975, 117). In the 1970s, DMJM produced striking high rise office structures in Los Angeles and bold, linear designs for academic campuses, including the Community College of Baltimore, Harbor Campus, as well as Holyoke (Massachusetts) and Northlake (near Dallas, Texas) Community College.

⁶⁷ Gavin Macrae-Gibson, "Pelli, Cesar," *The Grove Dictionary of Art Online*, (Oxford University Press, Accessed 15 October 2004), <<http://www.groveart.com>>

⁶⁸ A list of awards can be consulted at www.cesar-pelli.com

Maryland Historical Trust

Maryland Inventory of Historic Properties Form

Inventory No. MC-13-59

Name
Continuation Sheet

Number 8 Page 22

1963 and 1965.⁶⁹ The landscape architect for COMSAT Laboratories was also highly accomplished and respected among his peers: Lester Collins (1914-1993) received a master's degree from the prestigious Landscape Architecture program at Harvard University in 1942, which he also directed before moving to Washington, D.C. in 1954, where he lived until 1981. His office (named for a time Collins, Simonds and Simonds) was involved with urban, campus and school design, as well as with projects for public parks and private gardens from Maine to Florida, some close to his Georgetown residence. Among his most important projects were the redesign of the sunken Hirshhorn Sculpture Garden at the Smithsonian Institution (completed in 1981), Inisfree, "a 1,000-acre public garden with oriental overtones in New York state," and the plan for the new town of Miami Lakes in Florida.⁷⁰ Mr. Collins spent time in Kyoto, Japan on a Fulbright fellowship and was elected Fellow of the American Society of Landscape Architects.

Pelli's Forward-looking Design Concepts

Cesar Pelli evaluates his design for COMSAT Laboratories as "a successful investigation in esthetics, technology and building planning."⁷¹ He also recalls that the "influences that were most in my mind at that time were not as much architectural, but aircraft construction and esthetics (...) I was pushing the envelope of avant-garde ideas of the moment." Indeed, COMSAT Laboratories reflects Pelli's emerging, and enduring commitment to "an architecture that celebrates life," that emphasizes "perception, lightness and change," that "is not in the empty building but in the vital interchange between building and participant."⁷² Reflecting on the COMSAT commission, Pelli also confides:

Perhaps the most significant aspect of this building is that it is now a very early example of high-technology design; an architectural direction that has become very strong, perhaps dominant in the last 20 years.⁷³

According to the renown critic and historian Reyner Banham, "High Tech" is a "stylistic term applied to the expressive use of modern technology, industrial components, equipment or materials in the design of architecture, interiors and furnishings."⁷⁴ This denomination was first used in print in 1977 (a decade after COMSAT Laboratories was designed) and was popularized the following year by Joan Kron and Susan Slesin in a book entitled *High-Tech: The Industrial Style and Source-book for the Home*. Arguing that "the industrial aesthetic in design ... is one of the most important design trends today," Kron and Slesin cited a number of buildings, most notably the Centre Georges Pompidou (1971-7) in Paris.

According to Banham, High Tech finds philosophical and aesthetic roots in London's Crystal Palace, built for the Great Exhibition of 1851 and one of Pelli's favorite building. This movement is "linked to the prestige of recent advanced engineering, as represented by space-vehicles for example"⁷⁵; it challenges concepts of compactness and pure geometry expounded by the Modern Movement's most famous exponents, Walter Gropius, Le Corbusier and Ludwig Mies van der Rohe. Instead, it borrows ideas and imagery from less well-known futurist, expressionist and constructivist architects. Banham saw High Tech as an essentially British movement, coming of

⁶⁹ "Dallas Firm Gets Big Area Contract," *Washington Post*, August 16, 1963, B6. Bateson also built the Nimitz Library at the U.S. Naval Academy (John Carl Warnecke architect, 1970-73).

⁷⁰ <http://www.jgarden.org/biographies>. Patricia Dane Rogers, "Appreciation; Even Mother Nature Bowed to Lester Collins," *Washington Post*, July 29, 1993, T 10. Marion Lynn Clark, "The 10-point Lester Collins garden plan," *Washington Post*, April 11, 1971.

⁷¹ E-mail interview with Cesar Pelli by Historic Preservation Section, September 21, 2004.

⁷² Cesar Pelli, *Contemporary Architects*, 614

⁷³ E-mail interview with Cesar Pelli by Historic Preservation Section, September 21, 2004.

⁷⁴ Reyner Banham, "High Tech," *The Grove Dictionary of Art Online*, (Oxford University Press, Accessed 15 October 2004), <<http://www.groveart.com>>

⁷⁵ Cesar Pelli. "Joseph Paxton's Crystal Palace," *A + U (Architecture and urbanism)*, n.2(113), February 1980, 3-14.

Maryland Historical Trust Maryland Inventory of Historic Properties Form

Inventory No. MC-13-59

Name
Continuation Sheet

Number 8 Page 23

age with the Reliance Controls Factory at Swindon, Wiltshire, completed in 1967 (the factory's designers, Richard Rogers and Norman Foster have become, like Cesar Pelli, internationally known and appreciated). Generally imbued with optimism, either whimsical or serene, High Tech became a viable alternative to Post-Modern Classicism, a movement often characterized by nostalgia and irony. While "PoMo" has few followers at present, High Tech has adapted to new imperatives of sustainability and still inspires many young architects throughout the world, as evidenced, for instance by the *Light Construction* exhibit held at the Museum of Modern Art, New York, in 1996.

Three major concepts associated with the High Tech ethos and esthetic inform Cesar Pelli's design for COMSAT Laboratories: first, the "machine in the garden"; second, linear composition; and, third, "skin tectonics." A fourth, superimposed, theme, is also of crucial importance: transparency.

The "Machine in the Garden"

Cesar Pelli passionately wanted the COMSAT complex "to feel as a man-made object carefully placed on a natural area."⁷⁶ He therefore interpreted and rejuvenated the modernist idea of placing a self-referential, free-standing "object-piece" in an unspoiled landscape, an idea that finds one of its most striking and endearing illustrations in Le Corbusier's Villa Savoye (1930) in Poissy.⁷⁷ In the United States, the concept of the "machine in the garden" began to take hold with the advent of suburban sprawl. An early example, albeit far from avant-garde in its styling, is Bethesda's Naval Hospital, which opened in 1942 - a pristine, mirage-like, construction on a sea of emerald grass.

Enhancing the dialectic between "nature" and "culture" - between Clarksburg's pastoral setting and the laboratories' mechanistic character - was of the utmost importance for Cesar Pelli:

Although the structure will not blend with nature, it is set up not against it but rather working with it. The landscape will retain the existing look of the Maryland countryside with no exotic plants or manicured areas. The courts will be fully planted and each court will be different in density of trees and earth forms.⁷⁸

Cesar Pelli specified the saving of isolated mature trees, including maple, sycamore, and beech woods. Aided by landscape architect Lester Collins, he deliberately sought to place the building halfway within a small forest so that the trees could be experienced from much of the building and screen the south parking lot and receiving yard. The landscape plan avoids long straight rows of trees or any formal plantings in favor of small groupings and strategically placed trees, indigenous to the area. Historical photographs indicate that the grass was tractor-mown from the beginning. (A test to leave part of the landscape in a more wild state did not have good results.) Despite being mown, the landscape is decidedly pastoral, not manicured.

Cesar Pelli wanted to carry into the interiors the machine aesthetic, what he called the "'advanced technology' man-made quality of the exterior," and to avoid all hand crafted elements and materials. With the exception of occasional and "carefully segregated" wall paneling in wood, as in the conference rooms, white reigned supreme inside COMSAT Laboratories: it had white walls and ceilings, white steel staircase rails, and white 9" vinyl asbestos tiles.⁷⁹ The interior has references to ocean liners, including the north lobby's white-pipe rail stair and the corridor's mezzanine railing. These types of allusions had been popularized in the 1920s by Le Corbusier.

⁷⁶ Original programmatic language from Cesar Pelli, 1967. Obtained from Cesar Pelli Associates, New Haven, Connecticut.

⁷⁷ A historical landmark, this house is presently owned by the French Ministry of Culture.

⁷⁸ Original programmatic language from Cesar Pelli, 1967. Obtained from Cesar Pelli Associates, New Haven, Connecticut.

⁷⁹ Cesar Pelli memorandum to Ben Frank Worley, October 20, 1967. The display cases in the main corridor, fabric banners, and red replacement vinyl floor tiles are all additions from the 1980s.

Maryland Historical Trust

Maryland Inventory of Historic Properties Form

Inventory No. MC-13-59

Name
Continuation Sheet

Number 6 Page 24

Linear Composition

Cesar Pelli also explained that the “complex and differentiated functions of the laboratories are organized along a public spine that allows each of the constituting elements to take a form suitable for its need, and to grow and change independently of the rest of the building.”⁸⁰ The sequence of captioned diagrams included in an original memorandum show his systematic and thoughtful consideration of programmatic and aesthetic needs. As indicated by the first diagram, the plan is generated by a “basic circulation” through a central spine, entered on one side by visitors and on the other by employees. Since COMSAT Laboratories is a “complex” as opposed to a discrete “building,” this longitudinal corridor is its “most important space:

This is the common room, the meeting room, the room away from work. It should therefore have its own life in the plan. It should not be a leftover. It deserves the best views and the better materials.

Adding rectangular unit blocks of varying sizes on either side of the spine, diagram # 2 clearly shows how “the complex is an aggregate of spaces off a main circulation line.” Diagram # 3 superimposes “secondary circulation lines,” including the ubiquitous catwalk that is viewed from I-270. Diagram # 4 locates mechanical services in one of the blocks and through the spine, making them “flexible, capable of growth and easy to service.” Diagrams # 5 and 6 indicate the occurrence of “predetermined growth” on the lower side of the spine (visible from I-270), by repeating existing units at regular intervals, and the free development of “undetermined growth” in the back of the spine. The final diagram shows how views, both to the surrounding countryside and to internal landscaped courts, were afforded from the central spine and the catwalk.

Although the facade along I-270 is finite at its northern and more public end, with its exhibition rotunda / porte cochère motif, the overall composition rejects traditional notions of centralized spatial hierarchy. In this regard, it relates to utopian projects of “linear cities” envisioned by Soviet Constructivists in the 1920s, by Los Angeles architect Richard Neutra in “Rush City, Reformed” (1923-27) and explorations by European contemporaries of Cesar Pelli, in particular the Italian architects Giancarlo De Carlo, Vittorio Gregotti and members of the Superstudio group. The lobby is integral to the glazed spine “rather than the usual wall-in sanctuary.”⁸¹ Glass walls sheath the primary corridors, lobby, library and cafeteria. The importance of the western glass corridor, the “catwalk” that is seen from I-270, was twofold: 1) it served as a connector between all of the laboratory wings, and 2) it closed the landscaped courts, but its distinctly glazed, narrow presence allowed the courts to remain visually open from the central spine. Pelli’s program noted: “From the exterior, and depending on the light conditions, the building will sometimes look like a single streamlined shape and sometimes like a sequence of courts and wings.”⁸² To stress linearity, Cesar Pelli specified the direction of joints: “We want to maintain continuity on the lines and surfaces (for example, the long fascia on the balcony in the main corridor should not be interrupted with any applied element or strong joints.) Long lines of light should align perfectly. Floor and ceiling tile should have the pattern direction running with the long axis of the space.”⁸³

Skin Tectonics

Cesar Pelli also clearly explains how he enclosed COMSAT Laboratories “in a skin of aluminum and glass” independent of the structural frame:

⁸⁰ Special Cesar Pelli issue, *A + U*, Tokyo, July 1985, 29.

⁸¹ McCoy, “Planned for change”

⁸² *Ibid.*

⁸³ *Ibid*

Maryland Historical Trust Maryland Inventory of Historic Properties Form

Inventory No. MC-13-59

Name
Continuation Sheet

Number 8 Page 25

The windows of the private offices are "punched holes" in the aluminum panels. The windows in the public and common spaces form continuous bands. The aluminum skin turns over, under and around in the three dimensional planes, suggesting a continuous wrapping of the complex volume and making visible its role independent from the structure. I arrived at the decision to design the modular skin of aluminum and glass not only because of its intellectual and aesthetic appeal but also because of the suitability of its character to the purpose of the building: to be a place where research, experimentation and construction of telecommunication satellites takes place.⁸⁴

While designing the project, Cesar Pelli specified:

The glass walls should be as flush as possible. . . . The same quality of flushness, of everything in one plane, is also needed in the aluminum walls. Actually the character of tight skins is not only important in each material but also as they come together: we want the aluminum to be flush with the glass and with the concrete, avoiding all unnecessary reveals. The joints in the aluminum wall should be as tight and crisp as we can get them.⁸⁵

In the same way as the "machine in the garden" concept and linear composition inform COMSAT's site plan and interior layout, respectively, the facades are direct expressions of the use of aluminum in thin prefabricated panels and slender, geometrical, mullions. Without aluminum, COMSAT Laboratories would not have looked so light and elegant. Using facade elements in aluminum was not unprecedented, though. Three of the most spectacular designs of the interwar period - the Cathedral of Learning in Pittsburg (Day and Klauder, 1925), the Chrysler (William van Alen, 1930) and Empire State (Shreve, Lamb and Harmon, 1931) Buildings in New York City - used "cast- or pressed-sheet aluminum spandrels (...) set in into a masonry back up."⁸⁶ A benchmark in the popularization of all-aluminum, non load-bearing, facades was a research and engineering building in Milwaukee, designed by Chicago architects Holabird and Root. Upon completion, it was published in the December 1931 issue of *Architectural Record*, with the following introduction:

Aluminum, as one of the metals and alloys which can be easily formed into many shapes and patterns and which eliminate many maintenance items from the consideration of costs, has these characteristics to recommend its use in architecture:

1. Availability in quantity and in all forms known to metal working.
2. Uniform physical and chemical properties.
3. Lightness (aluminum and aluminum alloys weigh only one-third as much as the other metals commonly employed in architecture).
4. Workability.
5. Comparative low costs as a raw material.
6. Reasonable freedom from attacks by the elements.
7. Strength (...)
9. Finish in varying shades of gray and with different surface textures
10. Plating and coloring.⁸⁷

⁸⁴ Cesar Pelli, "Architectural Form and the Tradition of Building" A+U, 1985, 29.

⁸⁵ Memorandum from Cesar Pelli to Ben Frank Worley, 20 October 1967. Obtained from the office of Cesar Pelli & Associates, New Haven, Connecticut.

⁸⁶ Stephen J. Kelly, "Aluminum," in Thomas Jester, ed., *Twentieth-century building materials: history and conservation* (New York, 1995), 47. The Empire State Building's aluminum spandrel panels were 4 feet 6 tall and 5 feet wide.

⁸⁷ Harold W. Vader, "Aluminum in Architecture," *Architectural Record* 70 (December 1931), 459.

Maryland Historical Trust

Maryland Inventory of Historic Properties Form

Inventory No. MC-13-59

Name
Continuation Sheet

Number 8 Page 26

However, in all the above-mentioned examples, aluminum was used in conjunction with other, non-metallic, materials and/or was ornamented. The French inventor-manufacturer Jean Prouvé (1901-1984), whom Cesar Pelli credits as his source of inspiration for COMSAT Laboratories, was the first to propel this material into the mainstream of Modernism.⁸⁸ According to noted historian Jean-Louis Cohen, his plain-looking facade panels for the Maison du Peuple (Beaudouin et Lods architects, 1936-9), in Clichy near Paris, "completely revolutionized" curtain-wall techniques.⁸⁹ In his foundry in the Lorraine region, Prouvé, who was "fascinated by the thin shells used in the car and aviation industries," produced prototypes for steel and aluminum components, metal furniture and lightweight housing units. He "established a range of construction possibilities using stamped or folded sheet-metal, which allowed him to cover vast surfaces both elegantly and cheaply." Prouvé's panelized aluminum facades for the Fédération du Bâtiment (Gravereaux and Lopez, architects, 1951) and an apartment building Square Mozart (Lionel Mirabeau architect, 1953), both in Paris, and for an exhibition hall (Paul Herbé and Maurice Gauthier architects, 1951) in Lille all anticipate those used at COMSAT Laboratories.⁹⁰

After World War II, the glass curtain wall became the signature of International style architects and many transparent facades were detailed with aluminum mullions, forming elegant patterns. A good example is the United Nations Secretariat Building (1947-53) in New York City, by Harrison and Abramovitz. Completed in 1948, the Equitable Building (Pietro Belluschi architect) employed war production surplus and borrowed from aircraft manufacturing methods to devise a minimalist but supremely elegant curtain wall of low aluminum spandrels and large glass panes. This epochal International Style design was an eye opener for many architects and manufacturers.

Indeed, the Aluminum Company of America played a crucial role in giving aluminum an architectural edge. As early as 1931, ALCOA had sponsored the revolutionary "Aluminaire House" (A. Lawrence Kocher and Albert Frey architects), "constructed with aluminum-pipe columns carrying a steel floor deck and clad with thin aluminum panels fixed to the frame with aluminum screws and washers."⁹¹ After the war, ALCOA commissioned several designs to Harrison and Abramovitz showcasing its products. Completed in 1948, the administration building for the Davenport, Iowa, plant producing rolled sheets and plates was a "gleaming package" in a rural setting. Its facade alternated ribbon windows and cast aluminum panels, measuring 4 ft x 7f 3 ¼ in., which were bolted to the steel frame and then placed against precast concrete panels.⁹² Completed in 1953, the head office in Pittsburgh was a skyscraper entirely sheathed with one-story high prefabricated panels. Each panel comprised a diamond-shaped sculptural spandrel in aluminum (anodized and pressed) and a punctured window with rounded corners, which anticipated those at COMSAT laboratories: "Rather than resting on a masonry parapet wall, the panels could be bolted to the structural frame. Aluminum's light weight meant the panels could be quickly hoisted into place and assembled with a minimum of heavy equipment."⁹³ At the same time, techniques to manufacture anodized aluminum "by building up the natural aluminum oxide coating in an electro-chemical bath" were perfected. Used also at COMSAT, anodic coating possessed an "outstanding resistance to atmospheric corrosion."⁹⁴

⁸⁸ (9/21/04)

⁸⁹ Jean-Louis +Cohen, "Prouvé, Jean," *The Grove Dictionary of Art Online*, (Oxford University Press, Accessed 15 October 2004), <<http://www.groveart.com>> The panels were executed with the help of structural engineer Vladimir Bodi who would later collaborate with Le Corbusier

⁹⁰ "Eléments de façade en aluminium étudiés et réalisés par les ateliers Jean Prouvé," *L'Architecture d'Aujourd'hui*, February 1955, 2-3.

⁹¹ Dennis P. Doordan, "From precious to pervasive : aluminum and architecture," in Sarah Nichols, *Aluminum by design* (Pittsburgh, 1 Carnegie Museum of Art ; New York : Harry N. Abrams, 2000), 97.

⁹² "New Alcoa administration building at the Davenport plant is a gleaming package," *Architectural Forum* June 1949, 76-80.

⁹³ Doordan, 104.

⁹⁴ Kelly, "Aluminum," 48.

Maryland Historical Trust Maryland Inventory of Historic Properties Form

Inventory No. MC-13-59

Name
Continuation Sheet

Number 8 Page 27

However, in the late 1960s, sharp angles were all the rage among American architects working for large corporations and only their most adventurous European and Japanese colleagues were venturing into sleek, High-Tech curvatures.⁹⁵

Cesar Pelli (who also wanted aluminum on the Environmental Test Laboratory, but settled for painted corrugated steel due to budgetary constraints) explains that the purpose of the aluminum skin was not only esthetic. It certainly gave the building "an exciting technological look appropriate to its purpose," but it also "served the needs of COMSAT that required that the building be built in an extremely short time" and by keeping out signals that might interfere with the technology being developed inside.⁹⁶ COMSAT Laboratories featured other state-of-the-art technical characteristics, such as dropped ceilings sheltering large service areas and automatic temperature control in each office. In true High-Tech mode, Pelli made sure that technical, economical and aesthetic concerns harmonized and sustained each other: for instance, the separate mechanical penthouses shorten the length and width of ducts while relieving the monotony of horizontal lines and enlivening the silhouette. COMSAT was also a landmark achievement in fast track design.⁹⁷ Cesar Pelli ventured that the speed with which the building was designed accounts for at least a part of its success story:

"It's an interesting footnote that this adventurous design of the COMSAT Building was produced in an incredible short period of time. I completed the design in one and a half months and the building started construction five months after DMJM was engaged."⁹⁸

Critical Fortune and Posterity

COMSAT Laboratories was in the limelight as early as its plans were made public. In 1968, it received a citation in the prestigious *Progressive Architecture* annual design award, which was in its fifteenth year. This was indeed an outstanding accomplishment: out of 671 submissions, only 12 were selected for awards or citations. That year, the jury was chaired by Lawrence B. Anderson, Dean of the School of Architecture and Planning at MIT, and included Gunnar Birkerts (a former Saarinen employee) and Romaldo Giurgola, two highly respected architects, as well as the maverick structural engineer Falzur Khan, the man behind Chicago's Sears Tower. Their comments were reproduced in *Progressive Architecture*:

- The wall impresses me, the skin of the building.
- It's a very rational building. The different functions in the whole building are expressed quite well by the different materials in the wall system.
- Very superior plan, organization, and a fine cross-section for providing mechanical services for the laboratories.⁹⁹

A photogenic building, which had no parallel in the United States, COMSAT Laboratories was extensively published in magazines targeted to a specialized, but diverse, audience. In December 1968, *Architecture & Engineering News*, a technically-oriented

⁹⁵ In particular the facades of COMSAT Laboratory are related to those of the Olivetti training school designed by British architect James Stirling in 1968 and built in 1971-72. The "wraparound" metallic look of COMSAT Laboratories is not unprecedented, as it was already present in Art Deco diners.

⁹⁶ E-mail interview with Cesar Pelli, September 21, 2004.

⁹⁷ One of the more well-known "fast-track" designed buildings in American history is the Pentagon, which was designed in just a few months. That building is not only listed on the National Register of Historic Places, but is a National Historic Landmark as well.

⁹⁸ Ibid.

⁹⁹ "Clarksburg, Maryland." *Progressive Architecture*. v. 49, January, 1968, 125. Cesar Pelli would earn another citation from *Progressive Architecture* in 1977, for the Winter Garden at the World Financial Center and a design award, in 1987, for his extension to the Pacific Center.

Maryland Historical Trust

Maryland Inventory of Historic Properties Form

Inventory No. MC-13-59

Name
Continuation Sheet

Number 8 Page 28

publication, gave a well informed account of its aesthetic and constructional characteristics. In August 1970, *Progressive Architecture* did not hesitate to devote a second article to COMSAT, with the attention-grabbing title "Technological Imagery: Turnpike Version." The article congratulated Pelli for devising "elements - organization, expansion, capabilities, and skin treatment - which elevate COMSAT to an 'image' building at less-than-image-price:"

Because the plan is fundamentally quite simple, it was relatively easy to allow things to occur where they wanted to. Stairs are where stairs should be, and they are boldly expressed. The same happens for offices, laboratories or loading dock - nothing is slighted, little is in excess. There is no hint of a temple about this building, and therein lies one of its greatest strengths.¹⁰⁰

The fact, as stated by *Progressive Architecture*, that COMSAT Laboratories had "broken out of supercontrolled haute architecture, within the visual tradition" led to its publication in Japan and Italy, two countries which, at the time, were at the cutting edge of architectural theory and practice.

COMSAT laboratories was the summation of Cesar Pelli's tenure at DMJM and represents an important breakthrough in his career. Dear to the heart of its designer, it has been extensively featured in the first three monographs devoted to Cesar Pelli. The special issue published in 1985 by the trend-setting Japanese journal *A+U (Architecture and Urbanism)* included an essay by critic John Pastier, with the following comments on COMSAT Laboratories:

It is Pelli's first built example of a metal skin, and its lightness, tautness and continuity embody his views of external walls as pure enclosing membranes freed from structural duties. This was also a major concern of the architectural culture of the period, as was the notion of expandability and capacity for change, effected here by open-ended spines serving individual functional modeules. Purpose too is nicely served by a High-Tech wrapping for a High-Tech use, and by a rational layout in which the main spine articulates zones of research and production.¹⁰¹

In a 1990 monograph, Pastier maintained that the Teledyne and COMSAT laboratories "became architectural metaphors for logical planning and orderly growth."¹⁰²

Reflecting the optimistic and experimental state of mind of the late 1960s, Pelli's design for COMSAT Laboratories anticipates that of another Modern Master, also at the beginning of his career: Richard Meier's Bronx Developmental Center, designed in 1970 and completed in 1977 boasted a linear layout and a panelized, aluminum skin (placed lengthwise, however), which had a clear anodized finish and was punctured by gasketed and rounded window. It had ocean liner details in the transparent lobby, and glazed bridges linking separate wings. The Bronx Developmental Center received many accolades when it was first completed, but was partially demolished in 2002.¹⁰³ Richard Meier, himself an AIA Gold Medal recipient, has made slick, square, panels (clad in white enamel) and large glazed surfaces, in the "COMSAT vein," his trademark. COMSAT Laboratories emboldened young architects who deemed sterile either a nostalgic return to pre-modern forms or pure "Miesian" geometry. For instance, Chicago's Stanley Tigerman used

¹⁰⁰ "Technological Imagery," 72.

¹⁰¹ John Pastier, "Cesar Pelli: The Architect as Servant," 86.

¹⁰² John Pastier, "The Evolution of an Architect," 15

¹⁰³ See Suzanne Stephens, "Bronx Development Center, New York, N.Y., Architecture cross-examined," *Progressive Architecture* 58 (July 1977), 43-54.

Maryland Historical Trust Maryland Inventory of Historic Properties Form

Inventory No. MC-13-59

Name
Continuation Sheet

Number 8 Page 29

Alcoa's aluminum facade panels, and "zipper-gasketed windows" to build a space age home (completed 1975) in Glencoe, complete with a domed observatory.¹⁰⁴

The sleek skin, metal and glass aesthetics reigned almost supreme in England in the 1970s, and has remained a strong direction among British architects. In his authoritative survey on *High Tech Architecture*, Colin Davies illustrates Sir Norman Foster's amenity building for the Fred Olsen shipping line in the London Docks (1971), as a "sleek skin of glass and Neoprene." Two examples of light, curved metallic "machines in the garden" comparable to COMSAT, also found in Davies' book, are Foster's Sainsbury Centre for Visual Arts (completed 1977) at the University of East Anglia, Norwich and Nicholas Grimshaw's Office and Workshop for Ladkarn Ltd. (completed 1985) in London.¹⁰⁵

Cesar Pelli noted that elements of COMSAT's design were used in later buildings: "The lineal organization of the COMSAT Building reappeared in several of my buildings, and so did the unitized construction of its walls."¹⁰⁶ He explored the idea of lining separate and movable pavilions along a luminous corridor in two experimental house designs: one drawn at the request of the organizers of the prestigious Venice Biennale, in 1976; the other for a "Houses for Sale" exhibition presented at the trendy Max Protext / Leo Castelli Gallery Galleries in October 1980.¹⁰⁷ The concept (humanized by details such as hipped roofs and trellises) became a reality in a 1979 commission for a large house in Montgomery County, one of the very few private residences ever designed by Cesar Pelli.¹⁰⁸ The four-story garden hall Pelli added to New York's Museum of Modern Art (1978-84), retained the luminous and linear quality as well as the ocean liner atmosphere of the COMSAT Laboratories. The corporate campus for Owens Corning World Headquarters (1994-96) in Toledo, Ohio is an "assemblage of component parts linked together by glass-enclosed connectors."¹⁰⁹

One cannot understand Pelli's Ronald Reagan Washington National Airport without knowing COMSAT Laboratories. The user-friendly airport concourse was conceived like the Laboratories' spine with its views to the landscape (in this case, the airfield and the Potomac River), thus celebrating life.

In sum, one cannot study Cesar Pelli's contribution to world architecture without being fully aware of his groundbreaking work at COMSAT. The work of all master architects is an evolving process; as cultural resource historians, we have an obligation to preserve not only works of their mature years, but also their youthful, forward looking experiments – especially those that were deemed successes from a functional and aesthetic standpoint.

¹⁰⁴ See Joan Kron and Susan Slesin, *High-Tech: The Industrial Style and Source-book for the Home*, New York: C.N. Potter, 1978, 19.

¹⁰⁵ Colin Davies, *High Tech Architecture*, New York: Rizzoli, 1988, 19, 58-6, 98-99

¹⁰⁶ *Ibid*

¹⁰⁷ Special Cesar Pelli issue, *A + U*, Tokyo, July 1985, 47-49 and 90-93.

¹⁰⁸ Michael Webb, "Architecture: Cesar Pelli," *Architectural Digest* 47 (July 1990), 124-129, 178.

¹⁰⁹ www.cesar_pelli.com/textOnly/projects

Maryland Historical Trust

Maryland Inventory of Historic Properties Form

Inventory No. MC-13-59

Name
Continuation Sheet

Number 8 Page 30

List of Figures

Fig. 1- Site plan for COMSAT Laboratories (Cesar Pelli for DMJM architect), Clarksburg, MD, prepared 1967
Source: Cesar Pelli & Associates Architects

Fig. 2- View from I-270, COMSAT Laboratories (Cesar Pelli for DMJM architect), Clarksburg, MD, taken c.1970
Source: Cesar Pelli & Associates Architects

Fig 3 - Photograph of model showing topography, COMSAT Laboratories (Cesar Pelli for DMJM architect), Clarksburg, MD, taken 1967
Source: Cesar Pelli & Associates Architects

Fig.4 - Photograph of model, COMSAT Laboratories (Cesar Pelli for DMJM architect), Clarksburg, MD, taken 1967.
Source: Cesar Pelli & Associates Architects

Fig.5 - Satellites behind the east side of the parking lot, COMSAT Laboratories, Clarksburg, MD, photograph taken 2002
Source: Mary Corbin Sies

Fig.6 - Axonometric View of exterior, COMSAT Laboratories (Cesar Pelli for DMJM architect), Clarksburg, MD, delineated 1967
Source: Cesar Pelli & Associates Architects

Fig.7 - Floor plans, COMSAT Laboratories (Cesar Pelli for DMJM architect), Clarksburg, MD, delineated 1967
Source: Cesar Pelli & Associates Architects

Fig.8a - Diagrammatic plans (from top to bottom # 1 - "basic Circulation" ; # 2 - "corridor and spaces"; # 3 "other circulation"), COMSAT Laboratories (Cesar Pelli for DMJM architect), Clarksburg, MD, delineated 1967
Source: Cesar Pelli & Associates Architects

Fig.8b - Diagrammatic plans (from top to bottom # 4- "service distribution" ; # 5 "predetermined growth"; # 6 "undetermined growth"), COMSAT Laboratories (Cesar Pelli for DMJM architect), Clarksburg, MD, delineated 1967
Source: Cesar Pelli & Associates Architects

Fig.8c - Diagrammatic plan showing "views," COMSAT Laboratories (Cesar Pelli for DMJM architect), Clarksburg, MD, delineated 1967
Source: Cesar Pelli & Associates Architects

Fig.9 - Transverse section across laboratory wing, COMSAT Laboratories (Cesar Pelli for DMJM architect), Clarksburg, MD, delineated 1967
Source: Cesar Pelli & Associates Architects

Fig.10 -Penthouses above laboratory wings, COMSAT Laboratories (Cesar Pelli for DMJM architect), Clarksburg, MD, photograph taken 2002
Source: Mary Corbin Sies

Maryland Historical Trust

Maryland Inventory of Historic Properties Form

Inventory No. MC-13-59

Name
Continuation Sheet

Number 8 Page 31

Fig. 11- Aerial view showing additions to original structure, COMSAT Laboratories (Cesar Pelli for DMJM architect), Clarksburg, MD, photograph taken c. 2004
Source: www.COMSAT-Legacy.org

Fig. 12 -Exterior view of Wing 4, COMSAT Laboratories (Cesar Pelli for DMJM architect), Clarksburg, MD, photograph taken 2002
Source: Mary Corbin Sies

Fig.13 - North Facade, COMSAT Laboratories (Cesar Pelli for DMJM architect), Clarksburg, MD, photograph taken 2002
Source: Mary Corbin Sies

Fig 14 - Facade studies for the office wing and the catwalk, COMSAT Laboratories (Cesar Pelli for DMJM architect), Clarksburg, MD, delineated 1967
Source: Cesar Pelli & Associates Architects

Fig.15 – Photograph from the central spine through the landscape to the catwalk, COMSAT Laboratories (Cesar Pelli for DMJM architect), Clarksburg, MD, taken 2002
Source: Mary Corbin Sies

Fig.16 - Construction details for parapet, base, and wall section, COMSAT Laboratories (Cesar Pelli for DMJM architect), Clarksburg, MD, delineated 1967-68
Source: Cesar Pelli & Associates Architects

Fig.17 - Interior photograph of lobby, COMSAT Laboratories (Cesar Pelli for DMJM architect), Clarksburg, MD, taken c.1970
Source: Cesar Pelli & Associates Architects

Fig.18 - Photograph of the Environmental Test Laboratory upon completion, COMSAT Laboratories (Cesar Pelli for DMJM architect), Clarksburg, MD, taken October 3, 1969
Source: John Gerace, Emcor Facilities Services and Mike Smith, LCOR Incorporated

Fig.19 - Photograph of the exhibition pavilion and northern facade under construction, COMSAT Laboratories (Cesar Pelli for DMJM architect), Clarksburg, MD, taken July 3, 1969
Source: John Gerace, Emcor Facilities Services and Mike Smith, LCOR Incorporated

Fig.20 - Photograph of the catwalk and wings under construction, COMSAT Laboratories (Cesar Pelli for DMJM architect), Clarksburg, MD, taken November 15, 1968.
Source: John Gerace, Emcor Facilities Services and Mike Smith, LCOR Incorporated

Fig.21 - Photograph of the office spaces under construction, COMSAT Laboratories (Cesar Pelli for DMJM architect), Clarksburg, MD, taken February 27, 1969.
Source: John Gerace, Emcor Facilities Services and Mike Smith, LCOR Incorporated

Fig.22 - President Kennedy signing the Communications Satellite Act in August 1962 that established COMSAT.
Source: www.COMSAT-legacy.org

Maryland Historical Trust Maryland Inventory of Historic Properties Form

Inventory No. MC-13-59

Name
Continuation Sheet

Number 8 Page 32

Fig.23 – Photograph of the “Calypso,” Jacques Cousteau’s boat. Cousteau used mobile satellites developed by COMSAT Laboratories on his voyages.

Source: www.COMSAT-legacy.org

Fig.24 - Cesar Pelli for DMJM, Teledyne Laboratories, Northridge, California, completed 1967

Source: *Architectural Forum*, July-August 1968.

Fig.25 - Examples of prefabricated aluminum panels devised by Jean Prouvé

Source: *L'Architecture d'Aujourd'hui*, February 1955

Fig.26 - Axonometric view, House (Cesar Pelli architect), Montgomery County, Maryland, delineated c. 1986

Source: *Architectural Digest*, July 1990.

Figure 27 – Aerial View Showing additions to Original Structure, COMSAT Laboratories. Hatching shows original, 1969 structure.

Maryland Historical Trust Maryland Inventory of Historic Properties Form

Inventory No. MC-13-59

Name
Continuation Sheet

Number 8 Page 33

BIBLIOGRAPHY – Section 7

- "Aluminum Membrane Envelops Satellite Laboratory," *Architecture & Engineering News* 11 (December 1968), 76-8.
Architectural Record. *Buildings for Research*. (New York: F.W. Dodge, 1958).
Architectural Review (Nov. 1969) (reprint of article on Teledyne and COMSAT buildings, photocopy from Cesar Pelli & Associates)
"Architecture of Cesar Pelli," (special issue), *Architecture and Urbanism* 71 (November 1976)
At the End of the Century: One Hundred Years of Architecture. (Los Angeles: The Museum of Contemporary Art and New York: Harry Abrams, 1998).
Banham, Reyner, "High Tech," *The Grove Dictionary of Art Online*, (Oxford University Press, Accessed 15 October 2004), <<http://www.groveart.com>>
Bredemeier, Kenneth, "I-70S: How Cow Country became Corridor City," *Washington Post* (December 31, 1973), A1.
Bylinsky, Gene. *High Tech: Window to the Future*. (Hong Kong: Intercontinental Publishing, 1985).
Cesar Pelli: Architecture of Response, (Tokyo, Japan: Delphi Research Inc., 1994)
"Clarksburg, Maryland," *Progressive Architecture* 49 (January 1968), 122-5.
Cohen, Jean-Louis, "Prouvé, Jean," *The Grove Dictionary of Art Online*, (Oxford University Press, Accessed 15 October 2004), <<http://www.groveart.com>>
Communications Satellite Corporation. COMSAT at 10: The First Decade of the Communications Satellite Corporation. (Washington, D.C.: The Corporation, 1973).
"Communication Satellite Corporation," *Kenchiku Bunka* (Tokyo) (October 1968).
"COMSAT Laboratories," (Vital Statistics of the Commission, photocopy from Cesar Pelli & Associates), n.p.
"COMSAT Laboratories, Citation: Progressive Architecture 15th Annual Design Awards (*Progressive Architecture*, 1968), 88ff.
"COMSAT Laboratories," (Miscellaneous plans, sketches, and details, photocopies from Cesar Pelli & Associates, New Haven, CT), n.p.
Crosbie, Michael J. *Cesar Pelli: recent themes*. (Basel, Switzerland: Birkhauser, 1998).
Davies, Colin. *High-Tech Architecture*. (New York: Rizzoli, 1988).
Doordan, Dennis P., "From precious to pervasive : aluminum and architecture," in Sarah Nichols, *Aluminum by Design*. (Pittsburgh, Pa.: Carnegie Museum of Art; New York: Harry N. Abrams, 2000).
DR, "Technological Imagery: Turnpike Version," *Progressive Architecture* 51 (August 1970), 70-5.
"Eléments de façade en aluminium étudiés et réalisés par les ateliers Jean Prouvé," *L'Architecture d'Aujourd'hui* (February 1955), 2-3.
Emanuel, Muriel, ed., "Cesar Pelli," in *Contemporary Architects* (New York : St. Martin's Press, 1980), 613.
Forgey, Benjamin , "Alluring Curves: Cesar Pelli's K Street Beauty is a Welcome Sight," *Washington Post* (August 3, 1996), C 1.
Galfund, Allan, *Satellite Pathways* 3 (November-December 1978), n.p.
Gandelsonas, Mario and John Pastier. *Cesar Pelli: Buildings and Projects, 1965-1990*. (New York: Rizzoli International Publications, Inc., 1990), 22-25.
Graham, Katherine. *Personal History*. (New York: Vintage Books, 1997), 295.
"High Tech" (special issue), *Space Design I* (1985)
<http://www.cesar-pelli.com> (Accessed October 2004)
http://www.nbm.org/Exhibits/Cesar_Pelli.html
<http://www.overturefoundation.com/pelli.htm>
Kautz, Ryan D. "Cesar Pelli's Comsat Laboratories: Form Implies Function," (unpublished seminar paper for ARCH 635, Prof. Isabelle Gournay, School of Architecture, University of Maryland, Spring 2002)
Stephen J. Kelly, "Aluminum," in Thomas Jester, ed., *Twentieth-century building materials: history and conservation* (New York: McGraw-Hill, 1995)

Maryland Historical Trust Maryland Inventory of Historic Properties Form

Inventory No. MC-13-59

Name

Continuation Sheet

Number 8 Page 34

-
- Kousoulas, Claudia D. and George W. Kousoulas, *Contemporary Architecture in Washington, D.C.* (Washington, D.C.: The Preservation Press; New York: Wiley, 1995), 251-2.
- "Laboratori in Campagna," *Domus* #496 (March 1971), 7-10.
- Lippman, Thomas W. "Clarksburg Seen Housing 75,000 Residents in Future", *Washington Post* (June 1, 1967), E 4.
- Maryland-National Capital Park and Planning Commission. *Approved and Adopted Clarksburg Master Plan & Hyattstown Special Study Area.* (M-NCPPC, 1994).
- Gavin Macrae-Gibson, "Pelli, Cesar," *The Grove Dictionary of Art Online*, (Oxford University Press, Accessed 15 October 2004), <<http://www.groveart.com>>
- McCoy, Esther, "Planned for Change: Cesar Pelli Designs an Adaptable Electronics Plant," *Architectural Forum* 129 (July/August 1968), 102-107.
- Esther McCoy, "Reflections on Cesar Pelli," *A+U* (July 1985), 15.
- Musolf, Lloyd D. *Uncle Sam's Private, Profitseeking Corporations: COMSAT, Fannie Mae, Amtrak, and Conrail.* (Lexington, Mass.: Lexington Books, 1983).
- "Office organization and procedures for present-day practice: organization for efficient practice 2: Daniel, Mann, Johnson and Mendenhall, archts. & engrs.," *Architectural Record* 127 (June 1960), 190.
- Page, Clinton A. "Names [The firm of Daniel, Mann, Johnson and Mendenhall], *Architecture and Engineering Record* 9 (June 1967), 104.
- Pastier, John. *Cesar Pelli* (New York: Whitney Library of design, 1980), 44-49.
- Cesar Pelli, "Architectural Form and the Tradition of Building" *A+U* (1985), 29.
- Pelli, Cesar. *Cesar Pelli: selected and current works.* (Mulgrave, Victoria : Images Publishing Group, 1993) 86-87
- Cesar Pelli, "Cesar Pelli," (Special issue), *A + U* (Tokyo) (July 1985), 29, 34-37 and 86.
- Cesar Pelli, Email communication with Modern Movement in Maryland (MOMOMA) team (21 September 2004).
- Cesar Pelli. "Joseph Paxton's Crystal Palace," *A + U (Architecture and urbanism)* 113 (February 1980), 3-14
- Pelli, Cesar. "Memorandum from Cesar Pelli to Ben Frank Worley). (20 October 1967. Obtained from the office of Cesar Pelli & Associates, New Haven, Connecticut).
- Pelli, Cesar. *Observations for Young Architects.* (New York, New York: Monacelli, 1999).
- Pelli, Cesar. "Pieces of the City," *Architectural Digest* (August 1988): 29-36.
- Pelli, Cesar, "Transparency - Physical and Perceptual," *A+U* 71 (November 1976), 77
- Pelli, Cesar, and Diana Balmori. *Global Architecture: Bell Telephone Corporation Research Laboratories, New Jersey, 1957-62; Deere & Company Headquarters Building, Illinois, 1957-63.* (Tokyo: A.D.A. Edita, 1971).
- "Plans Set for IBM Gaithersburg Unit," *Washington Post* (May 31, 1965), D10
- Ross, Michael Franklin. "The Development of an Esthetic System at DMJM," *Architectural Record* 57 (May 1975), 111-120.
- Smith, Herbert L., Jr., ed. *An Architectural Record Book: Buildings for Research.* (New York: F.W. Dodge Corporation, 1958).
- "Space Industries' Demanding Criteria," *Architectural Record* (July 1964), 169.
- Sween, Jane and William Offutt. *Montgomery County: Centuries of Change.* (Sun Valley, California: American Historical Press, 1999)
- Tedeschi, Anthony Michael. *Live, Via Satellite: The Story of COMSAT and the Technology that Changed World Communication,* (Washington, D.C.: Acropolis Books, Ltd., 1989).
- Temko, Allan. Eero Saarinen. (New York: G. Braziller, 1962).
- Three Centuries of Maryland Architecture: a selection of presentations made at the 11th Conference of the Maryland Historic Trust.* (Crownsville: Maryland Historical Trust, 1982), 226
- United States Department of State, *Department of State Bulletin* (January 16, 1961), 77.
- Vader, Harold W. "Aluminum in Architecture," *Architectural Record* 70 (December 1931), 459.
- Webb, Michael "Architecture: Cesar Pelli," *Architectural Digest* 47 (July 1990), 124-129, 178.

Maryland Historical Trust Maryland Inventory of Historic Properties Form

Inventory No. MC-13-59

Name
Continuation Sheet

Number 8 Page 35

BIBLIOGRAPHY – Section 8

Communications Satellite Corporation, *Comsat at 10 : the first decade of the Communications Satellite Corporation*, Washington : The Corp., [1973]
Allan Galfund, *Satellite Pathways* 3 (November-December 1978), cover, no pag.
Lloyd D. Musolf, *Uncle Sam's Private, Profitseeking Corporations: COMSAT, Fannie Mae, Amtrak, and Conrail*. Lexington, Mass.: Lexington Books, 1983
Anthony Michael Tedeschi, *Live via Satellite* Washington, D.C.: Acropolis Books, 1989

Articles on COMSAT Laboratories

“Clarksburg, Maryland.” *Progressive Architecture*. v. 49, January, 1968, pp. 122-5, illus. Plans, diagrams.
“Communication Satellite Corporation,” *Kenchiku Bunka* (Tokyo), October 1968, 49.
“Aluminum Membrane Envelops Satellite Laboratory.” *Architecture & Engineering News* 11 (December 1968) 76-78.
D.R. ., “Technological Imagery: Turnpike Version.” *Progressive Architecture*. v. 51, August, 1970, 70-75.
“Laboratori in Campagna,” *Domus* n. 496, March, 1971, 7-11..
J. Pastier: *Cesar Pelli* (New York, 1980), 44-49.
Three Centuries of Maryland Architecture, Maryland Historical Trust; 1982. p.226
Special Cesar Pelli issue, *A + U*, Tokyo, July 1985, 29, 34-37 and 86.
Gandelsonas, Mario and John Pastier, *Cesar Pelli: Buildings and Projects, 1965-1990*, New York: Rizzoli International Publications, Inc., 1990, 22-25.
Cesar Pelli : selected and current works Mulgrave, Victoria : Images Pub. Group, 1993, 86-87
Ryan D. Kautz, *Cesar Pelli's Comsat Laboratories: Form Implies Function*, seminar paper ARCH 635 (Prof. Isabelle Gournay), School of Architecture, University of Maryland, Spring 2002
<http://www.cesar-pelli.com>

MATERIALS FROM CESAR PELLI & ASSOCIATES ARCHITECTS

Photographs of:

Original plans
Original models
Original renderings

Correspondence

Materials from COMSAT Laboratories Building Management Company, Emcor Facilities Services

Original construction photographs taken by Stewart Bros. For Bateson Construction Company, circa 1969

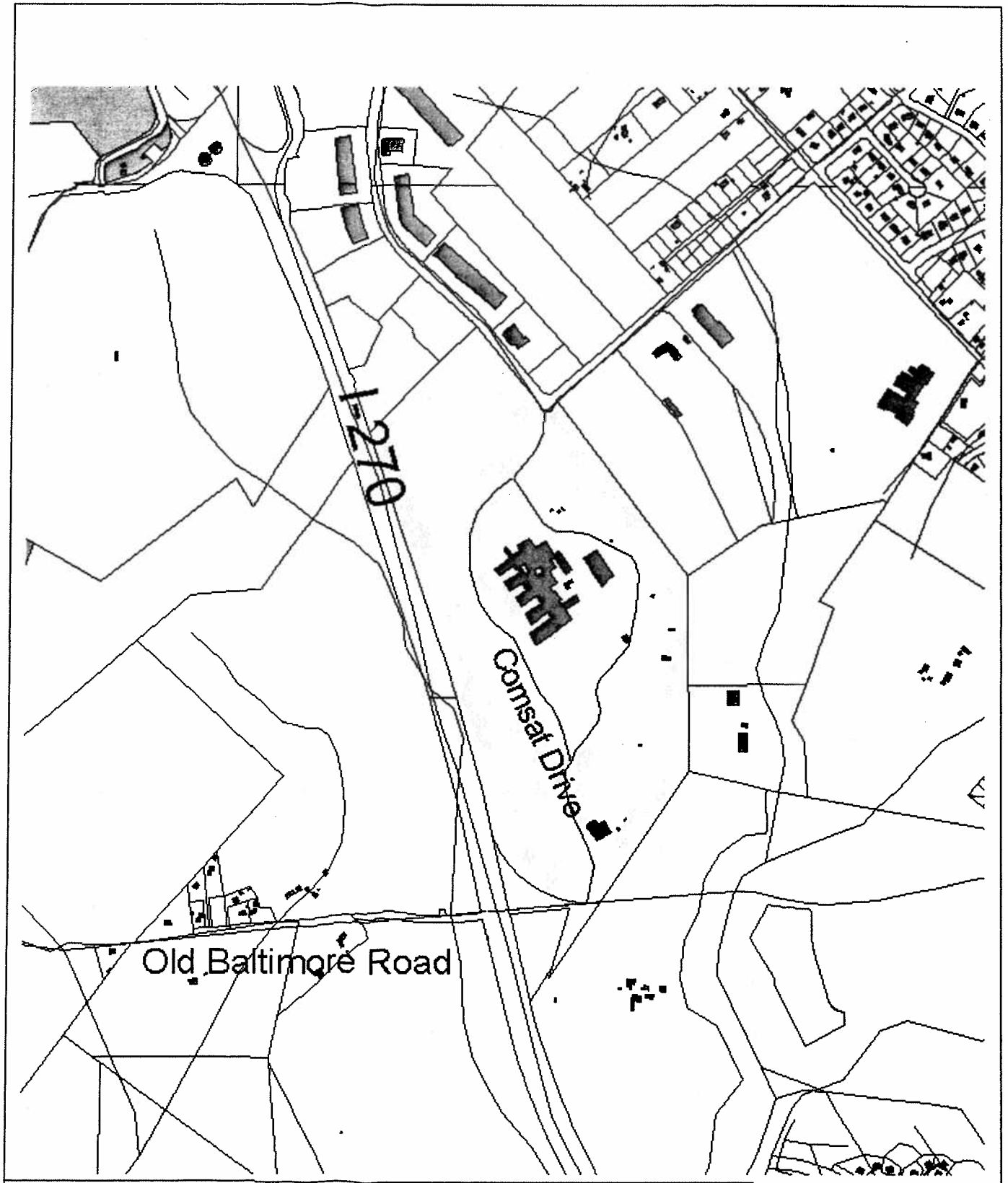

Cursor User Application

COMSAT Laboratories, 22300 Comsat Drive, Clarksburg



GIS Site Map

Map 1

7.5 MINUTE SERIES (TOPOGRAPHIC)

5564
DAMAC

HAGERSTOWN 36 MI.
FREDERICK 40 12 MI
302 17'30"

1720 000 FEET

304

2.5 MI. TO MD. 123

305

77°15'

39°15'

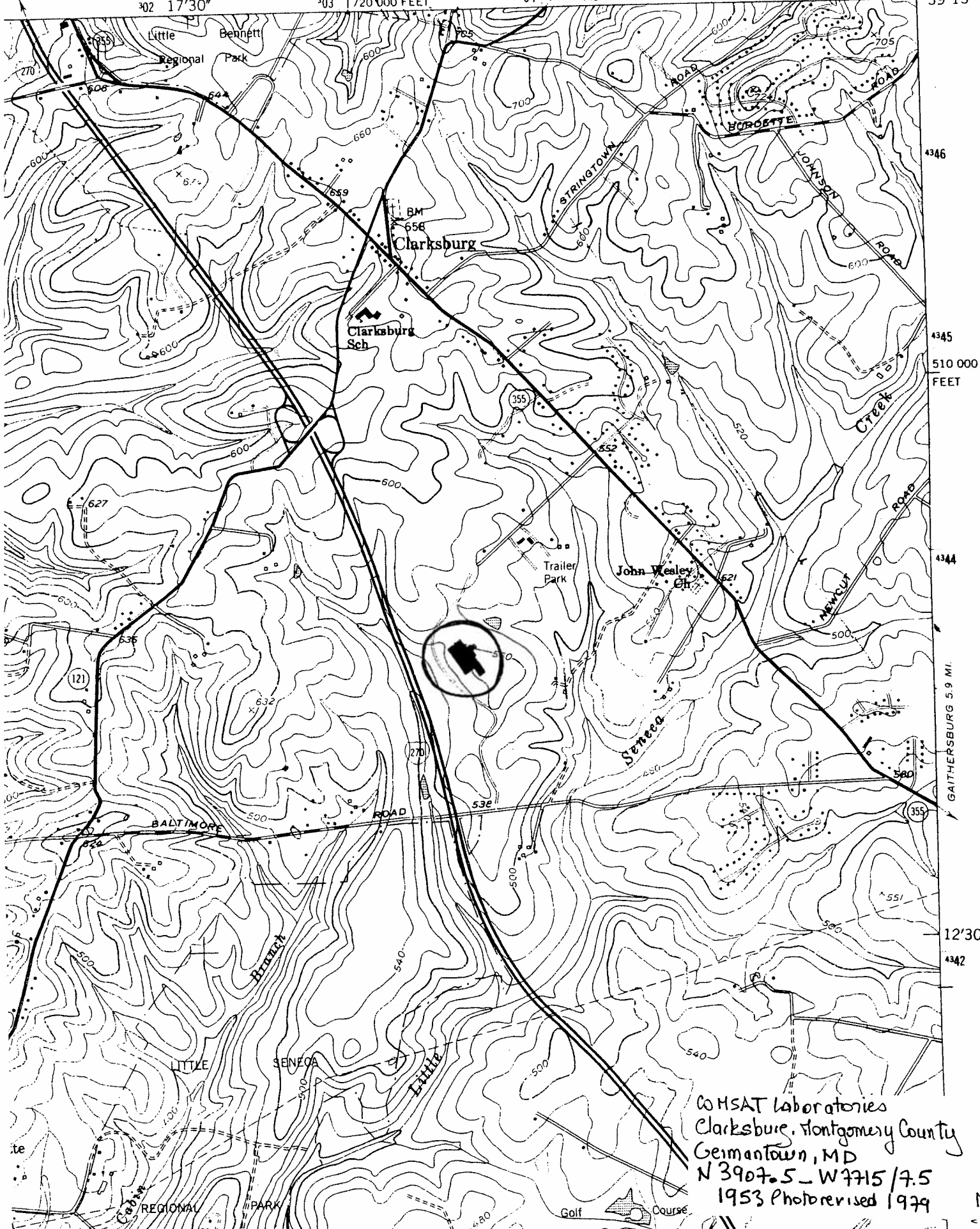

COMSAT Laboratories
Clarksburg, Montgomery County
Germantown, MD
N 3907.5 - W 7715 / 7.5
1953 Photorevised 1979

Map:



Fig. 1- Site Plan for COMSAT Laboratories (Cesar Pelli for DMJM architect), Clarksburg, MD
prepared 1967
Source: Cesar Pelli & Associates Architects

Fig. 2 - View from I-270, COMSAT Laboratories (Cesar Pelli for BSM architects),
Clarksburg, MD, taken 1967. Source: Cesar Pelli & Associates Architects

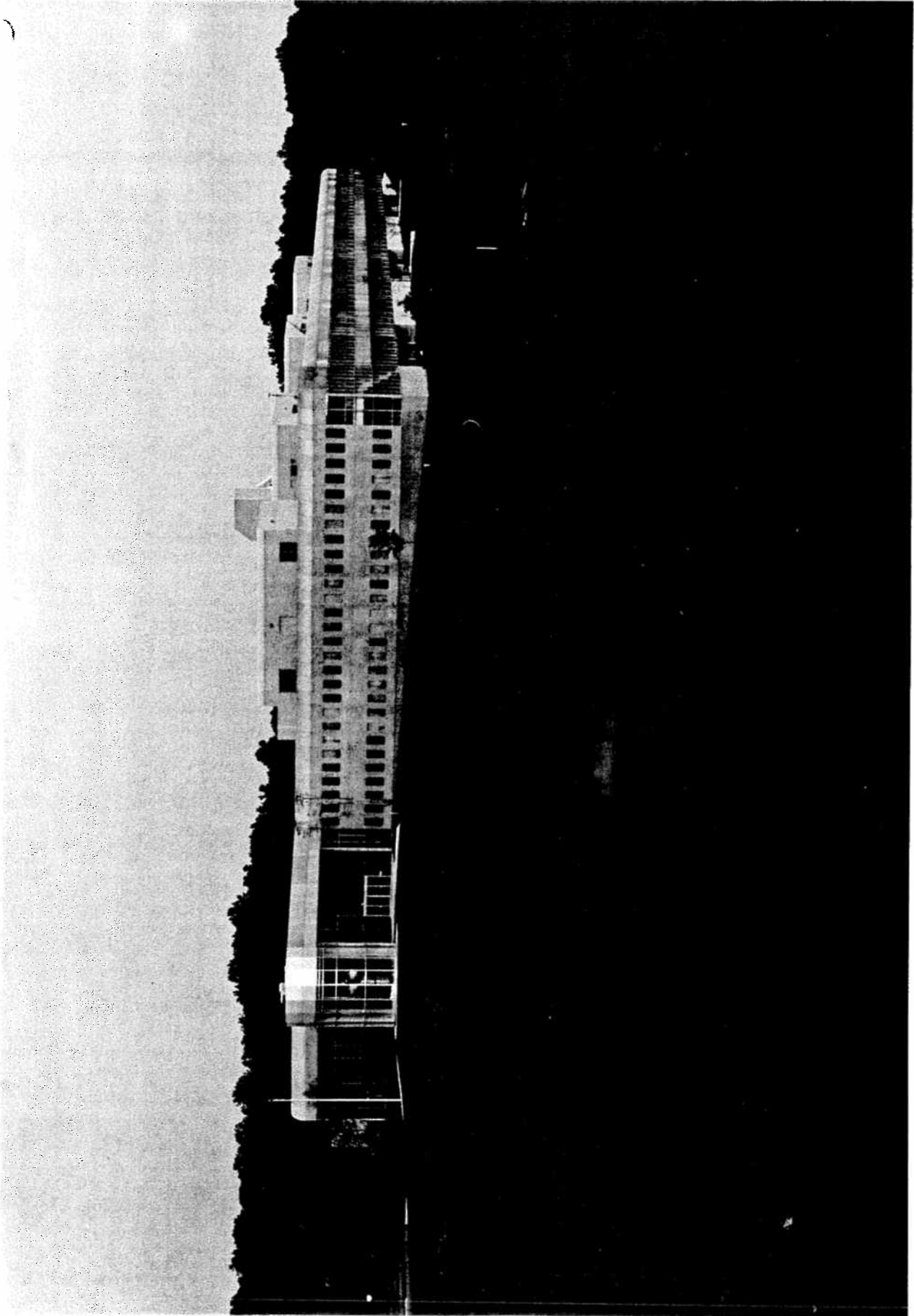

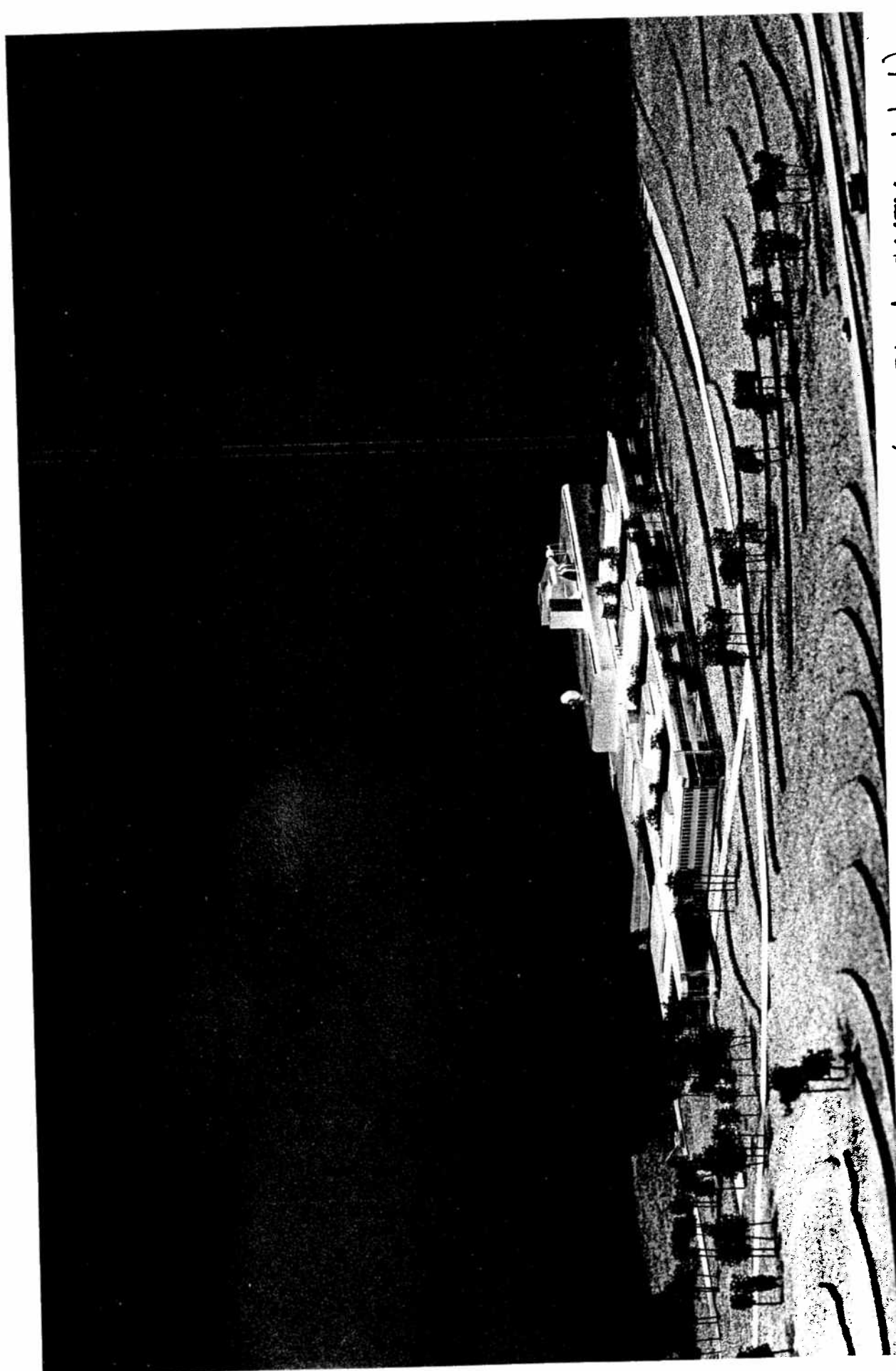

Fig. 3 - Photograph of model showing topography, COMSAT Laboratories (Cesar Pelli for DMJM architect), Clarksburg, MD, taken 1967 - Source: Cesar Pelli & Associates Architects

Fig. 4 - Photograph of model, COMSAT Laboratories (Cesar Pelli for DMSM Architect), Clarksburg, MD
taken 1967 - Source: Cesar Pelli & Associates Architects

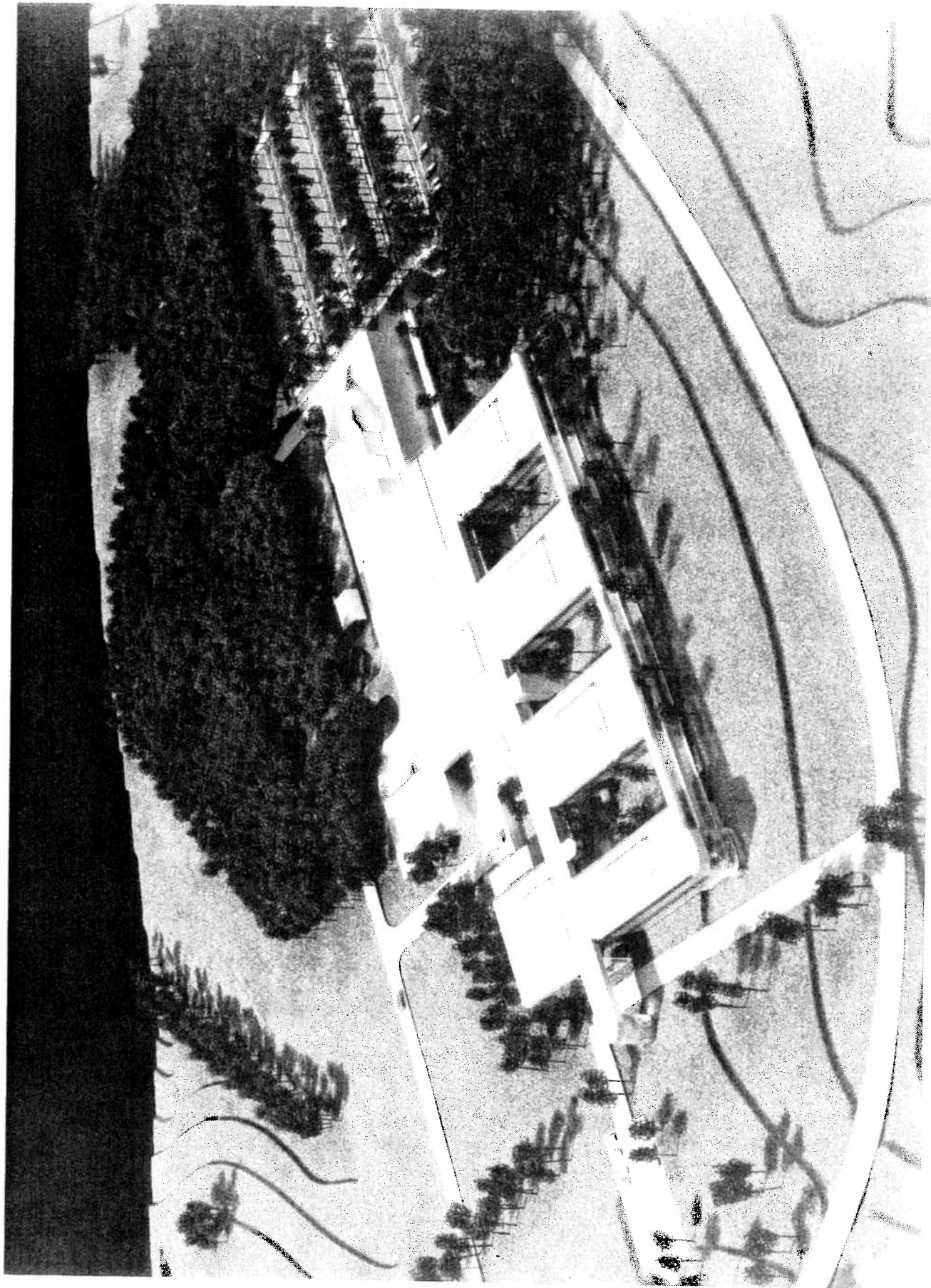



Fig.5 - Photograph of Satellites behind the east side, COMSAT Laboratories (Cesar Pelli for DMJM architect) Clarksburg, MD. Source: Mary Corbin Sies, 2002

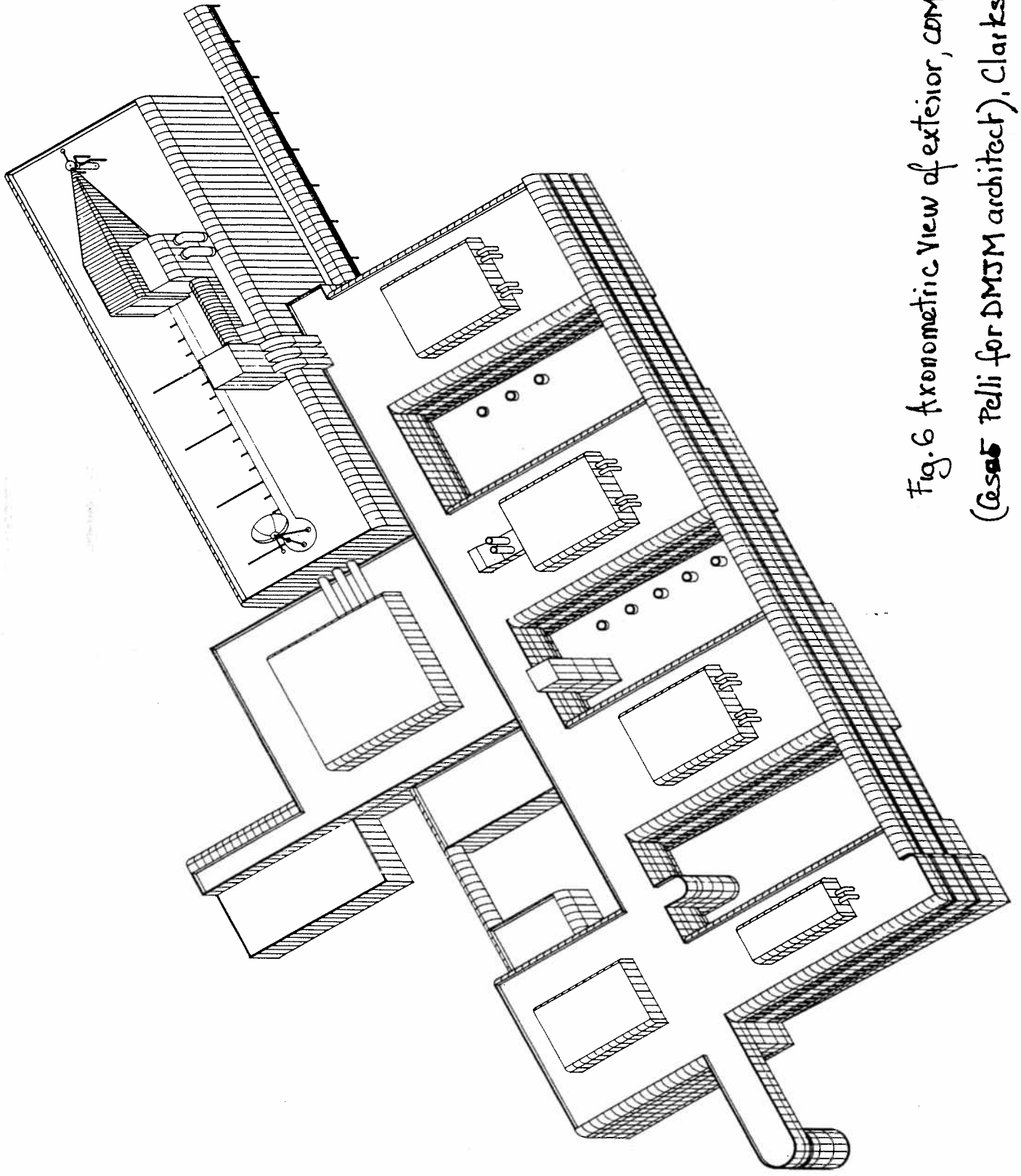
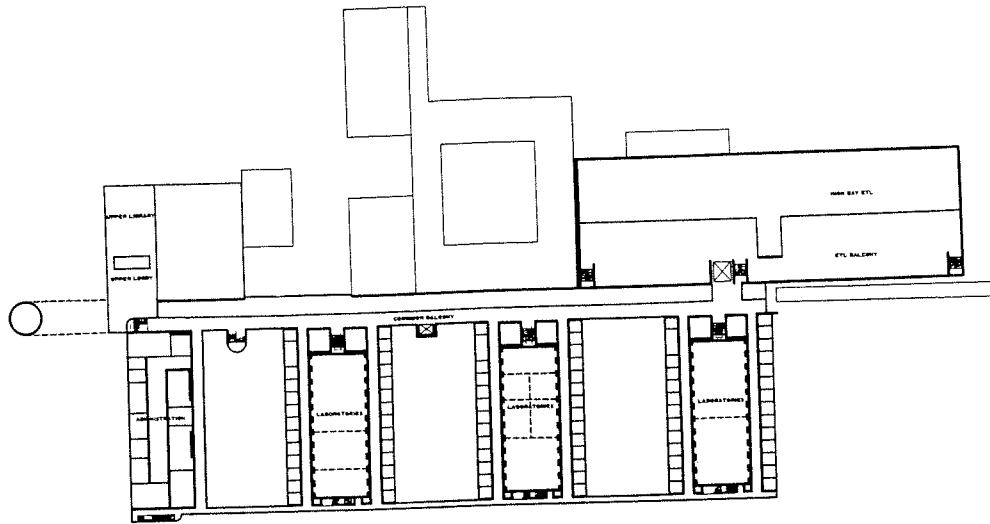
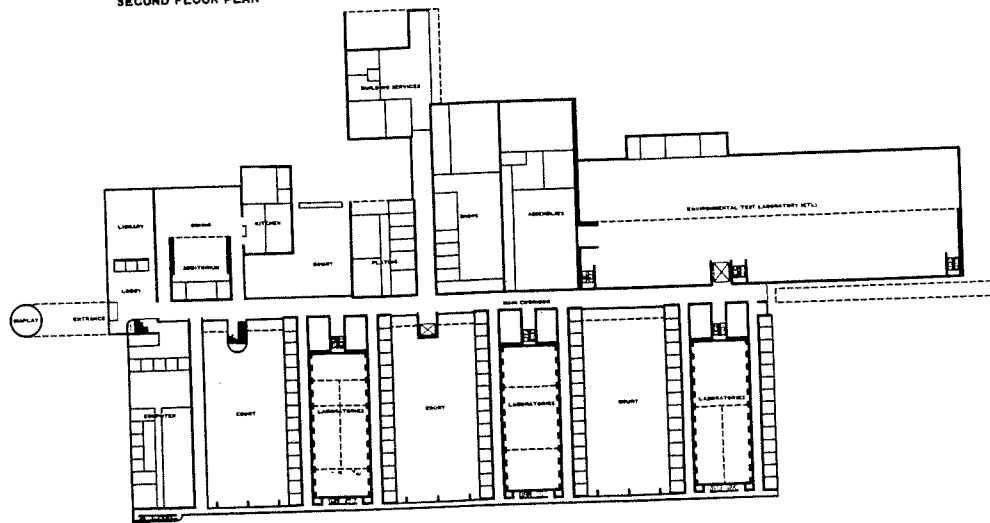

Fig. 6 Axonometric View of exterior, COMSAT Laboratories
(Cesar Pelli for DMJM architect), Clarksburg, MD,
delineated 1967. Source: Cesar Pelli & Associates Architects



SECOND FLOOR PLAN



FIRST FLOOR PLAN

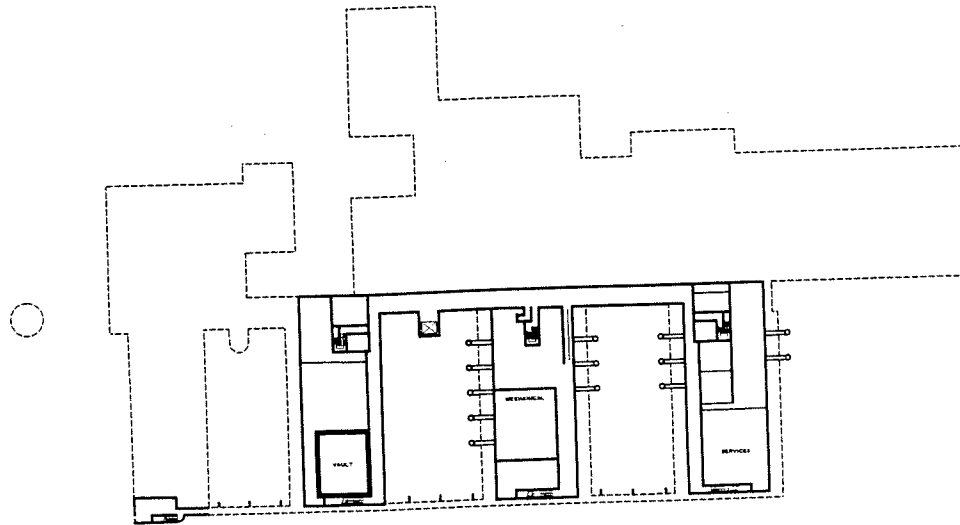

BASEMENT PLAN

Fig 7 - Floor plans, COMSAT Laboratories (Cesar Pelli for DMJM architect)
 Clarksburg, MD, delineated 1967 - Source: Cesar Pelli & Associates Architects

PLAN

The plan is generated by the circulation.

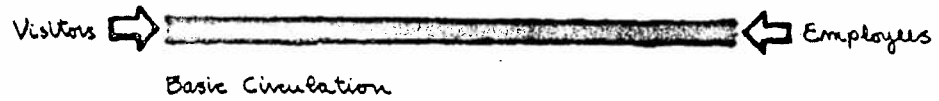

There are spaces and there are circulation lines.

The complex is planned as an aggregate of spaces off a main circulation line.

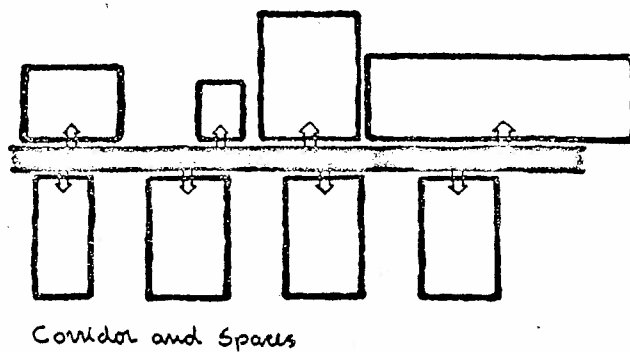

Secondary circulation lines complete the network.

The circulation is for people and for materials.

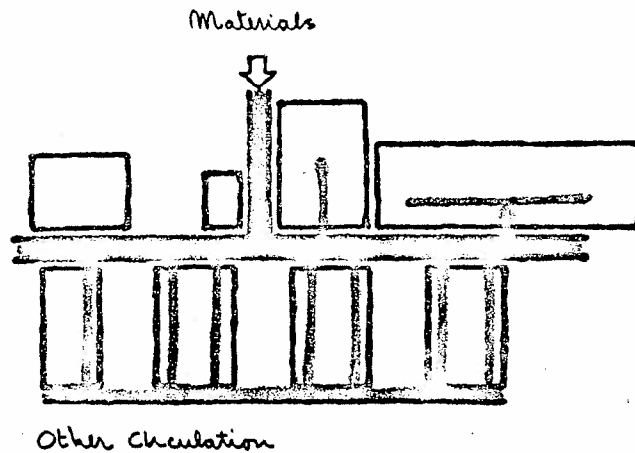
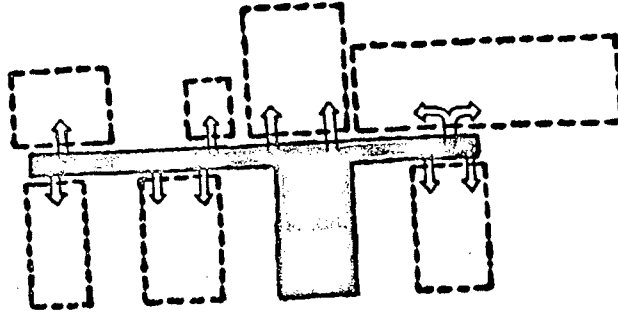

Fig. 8 a. Diagrammatic plans (from top to bottom # 1 - "Basic circulation"; # 2 - "Corridor and spaces"; # 3 "other circulation"), COMSAT Laboratories, Clarksburg MD (Cesar Pelli for DMJM architect) delineated 1967 (Source: Cesar Pelli's Associates Architects)

Mechanical services follow the same pattern and are therefore flexible, capable of growth and easy to service.



Service distribution

Some functions will expand in a predetermined order. Its needs are clear; growth can be anticipated.

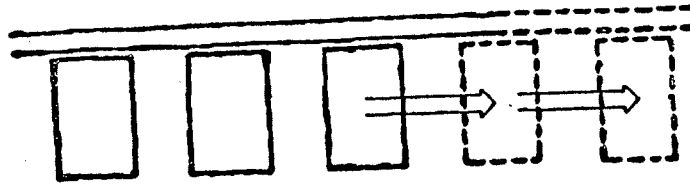

Predetermined growth

Some functions will need expansion but the specific future needs cannot be foreseen. The plan is purposely not composed and it is therefore unfinished, open ended.

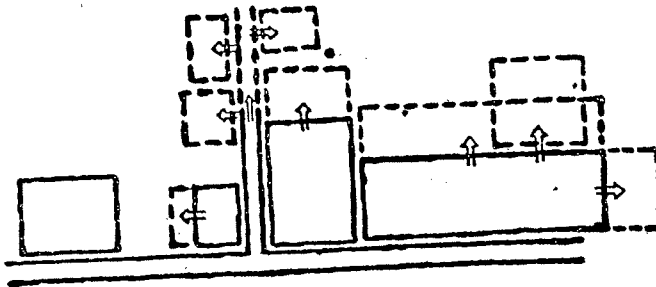

Undetermined growth

Fig. 8-b - Diagrammatic plans (from top to bottom #4 - service distribution; #5 "predetermined growth"; #6 "undetermined growth") COMSAT Laboratories, Clarksburg, MD (Cesar Pelli for DMJM architect), delineated 1967
Cesar Pelli & Associates Architects

A complex is different from a building. In a complex, the corridor is the most important space. This is the common room, the meeting room, the room away from work. It should therefore have its own life in the plan. It should not be a leftover. It deserves the best views and the better materials.

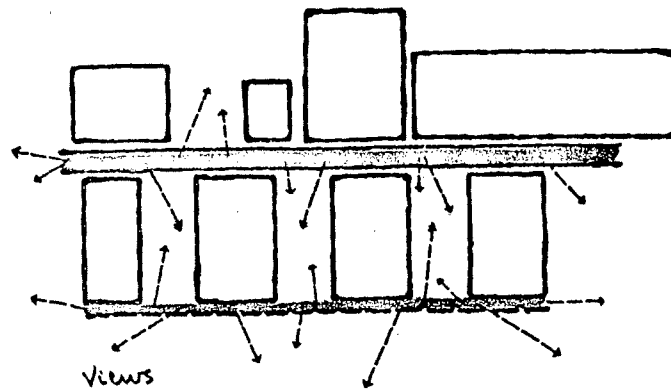

Fig. 8C - Diagrammatic plan showing "views", COMSAT Laboratories (Cesar Pelli for DMJM architect), COMSAT Laboratories, Clarksburg, MD, delineated 1967
Source: Cesar Pelli & Associates Architects

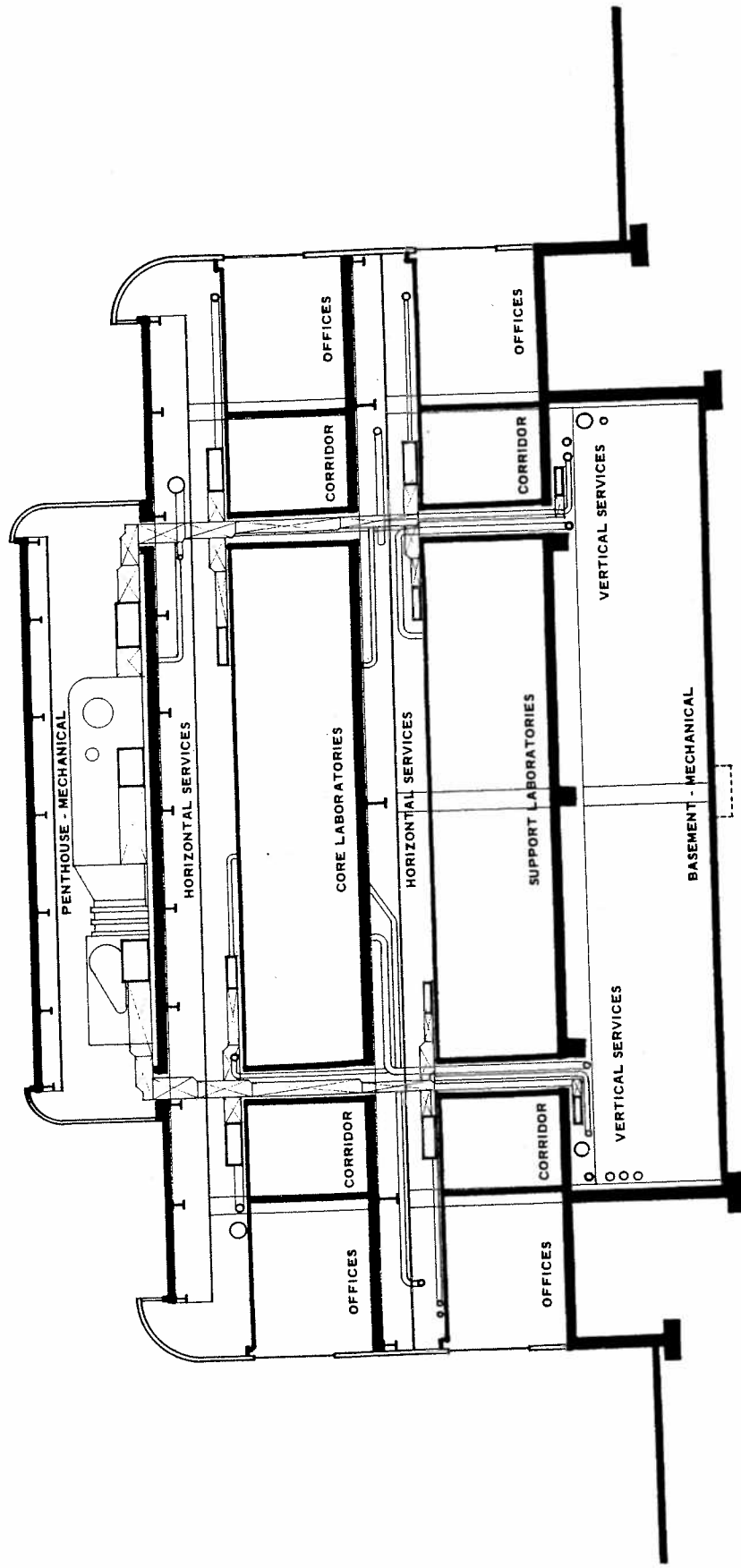

Fig. 9 - Transverse section across laboratory wing, COMSAT Laboratories
 (Cesar Pelli for DMJM architect), Clarksburg, MD, delineated 1967
 Source: Cesar Pelli & Associates Architects

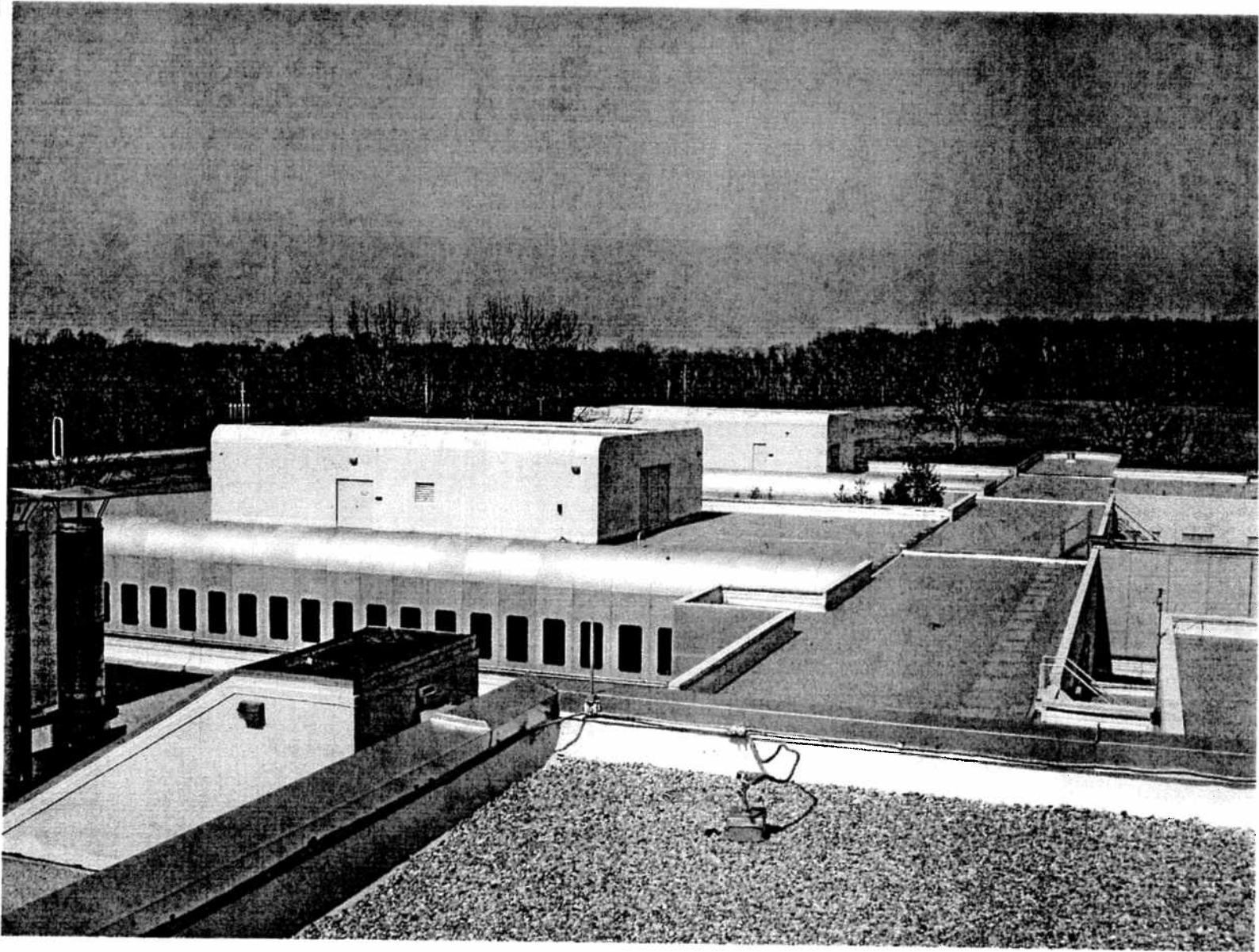

Fig. 10 - Penthouses above laboratory wings, COMSAT Laboratories (Cesar Pelli for DMO) architect, Clarksburg, MD, photograph taken 2002 - Source: Mary Corbin Sies

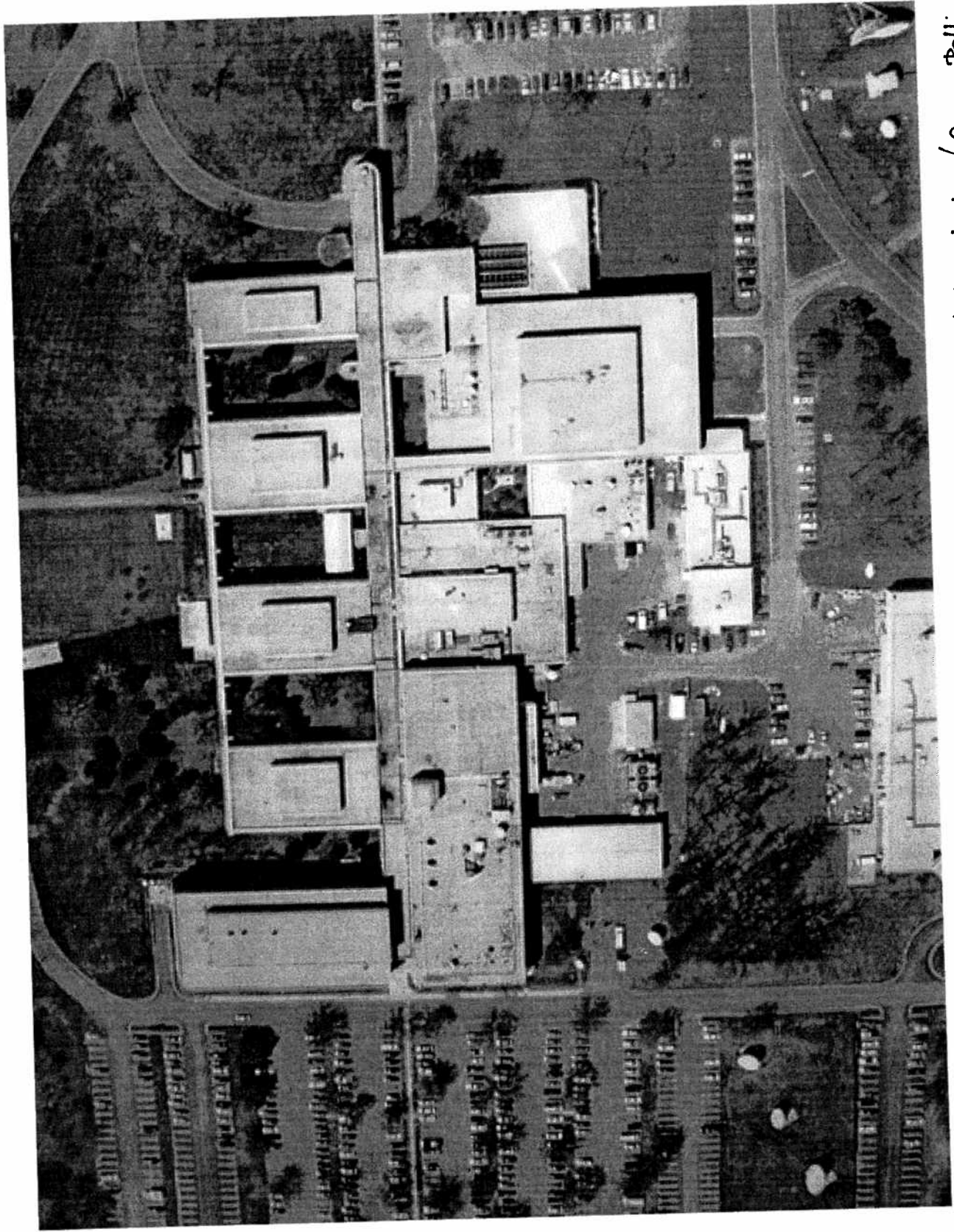

Fig. 11. Aerial view showing additions to original structure, COMSAT Laboratories (Cesar Pelli for DMJM architect) Clarksburg MD, photograph taken c. 2004 Source: www.COMSAT-Legacy.org

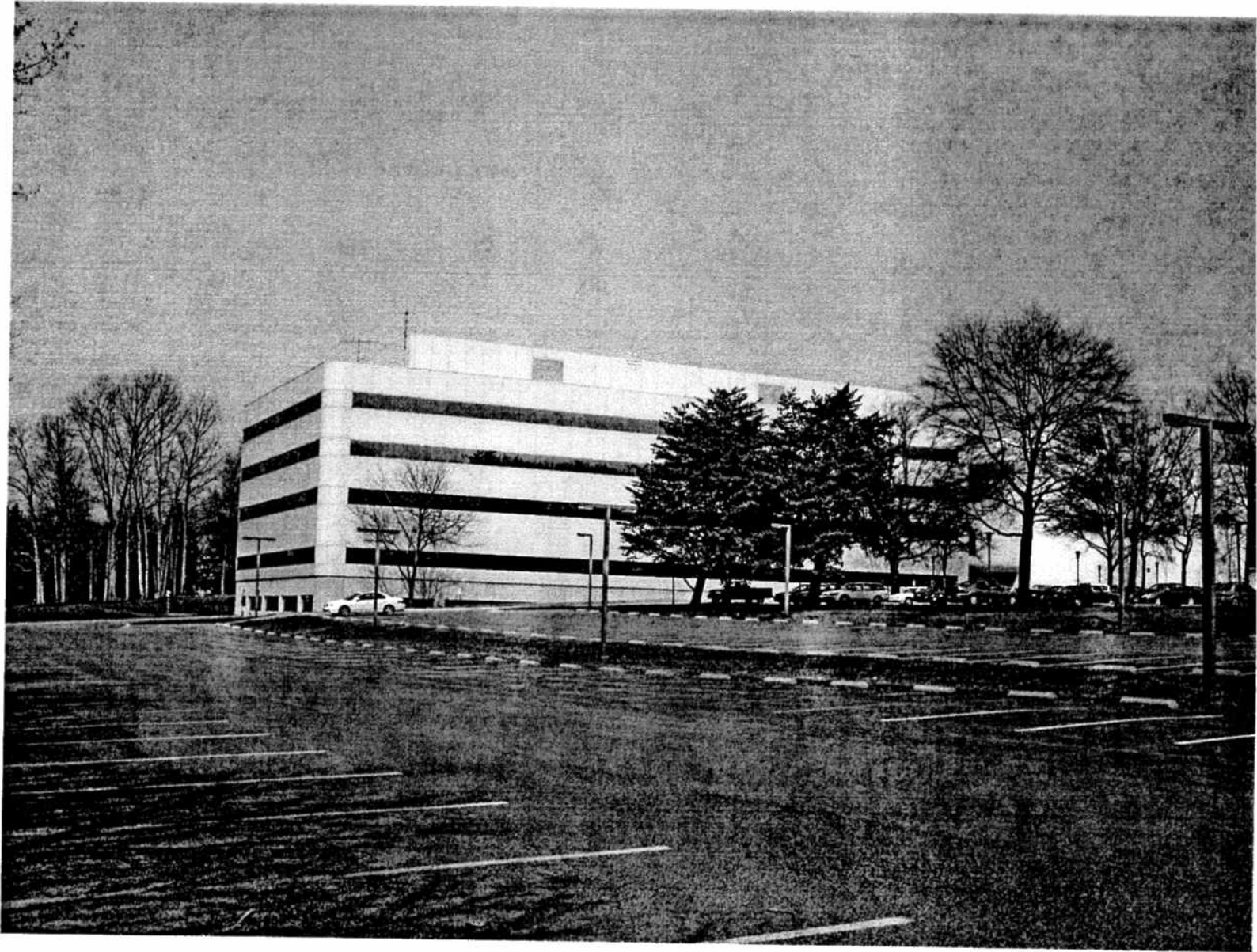

Fig. 12 - Exterior view of Wing 4, COMSAT Laboratories (Cesar Pelli for DMJM architect).
Clarksburg, MD, photograph taken 2002 - Source: Mary Corbin Sies

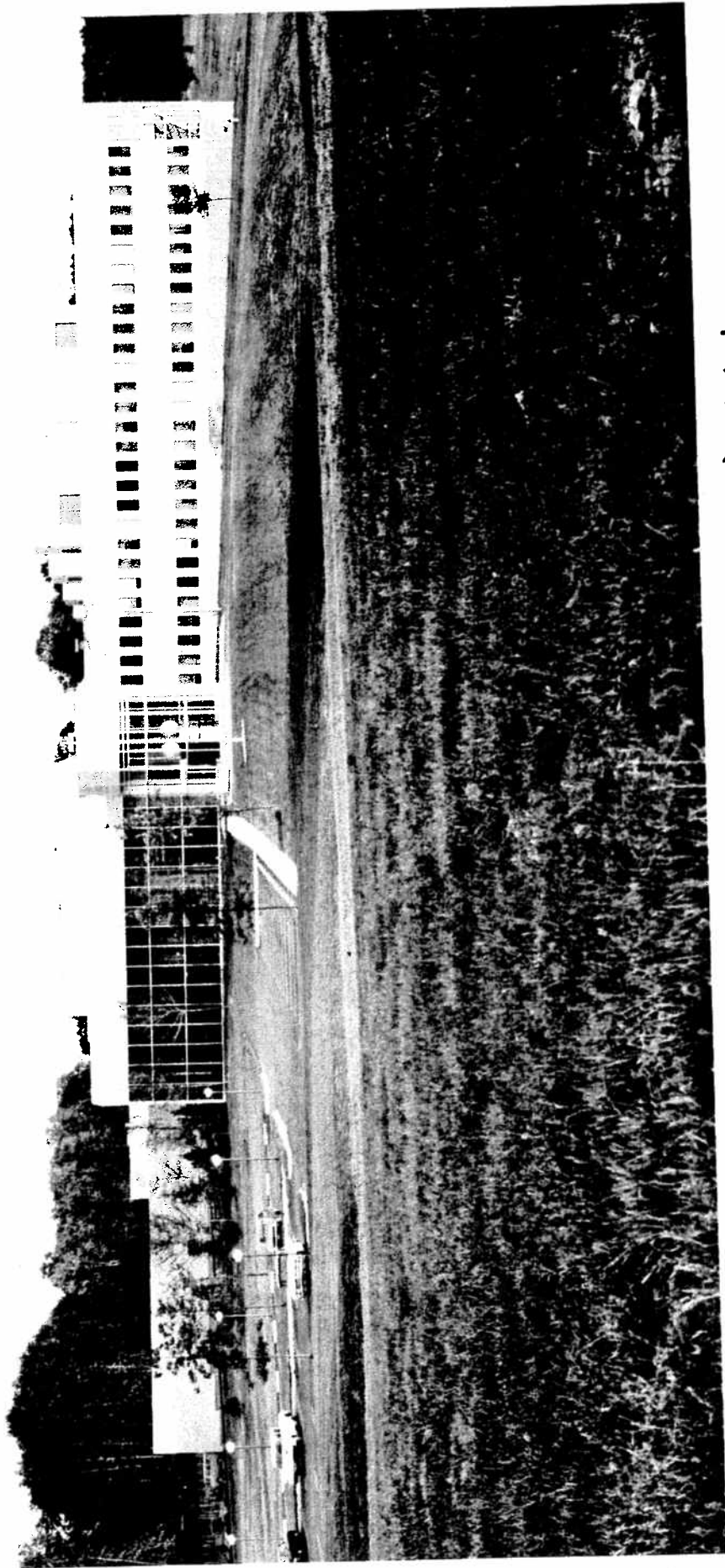

Fig. 13 - North facade, COMSAT Laboratories (Cesar Pelli for DMJM architect), Clarksburg, MD
Photograph taken 2002 - Source: Mary Corbin Sies

Fig. 14 - Facade Studies for the office wing and the eatwalk, COMSAT Laboratories (Cesar Pelli for PHS Architects)
Clarksburg, MD, delineated 1967. Source: Cesar Pelli & Associates Architects

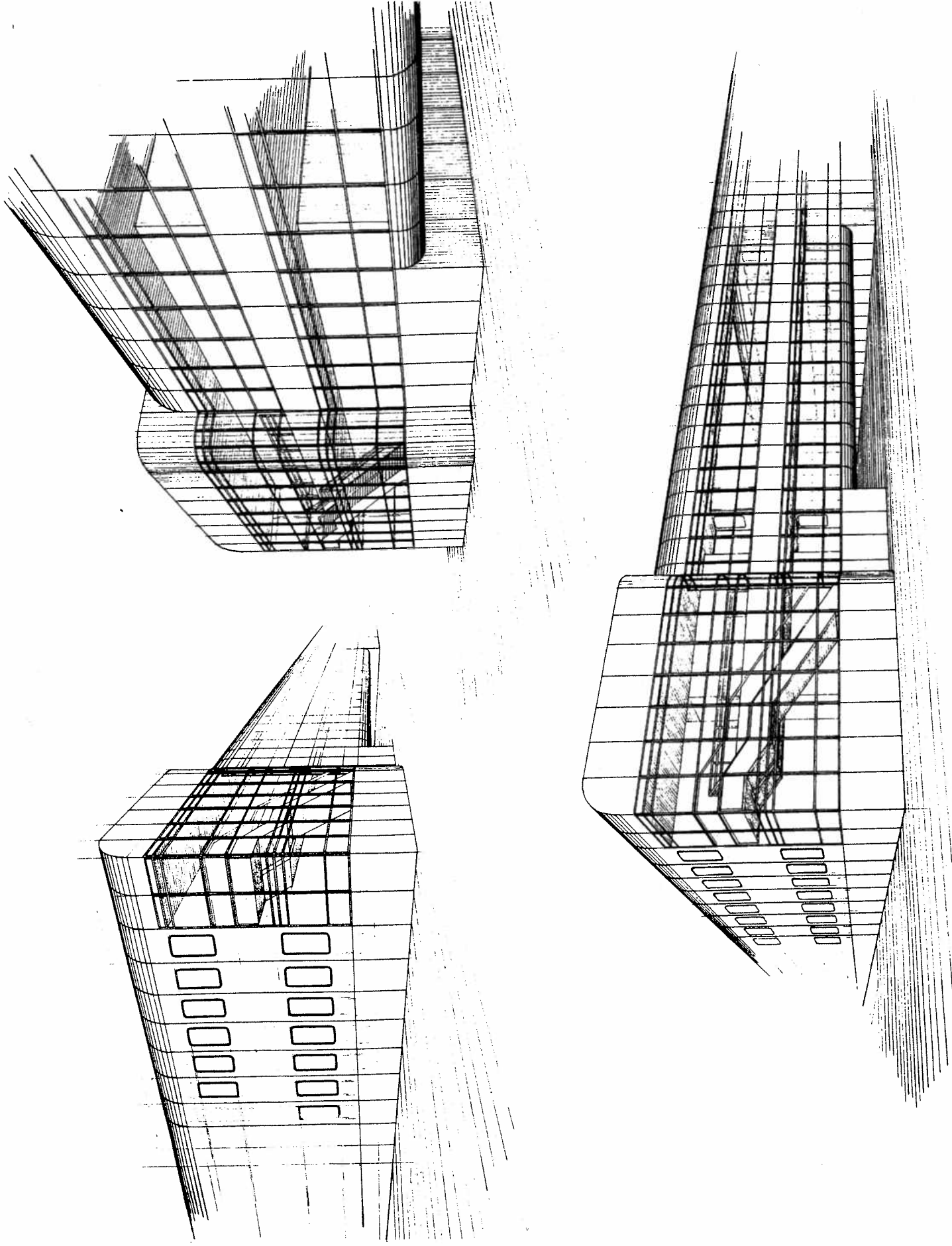
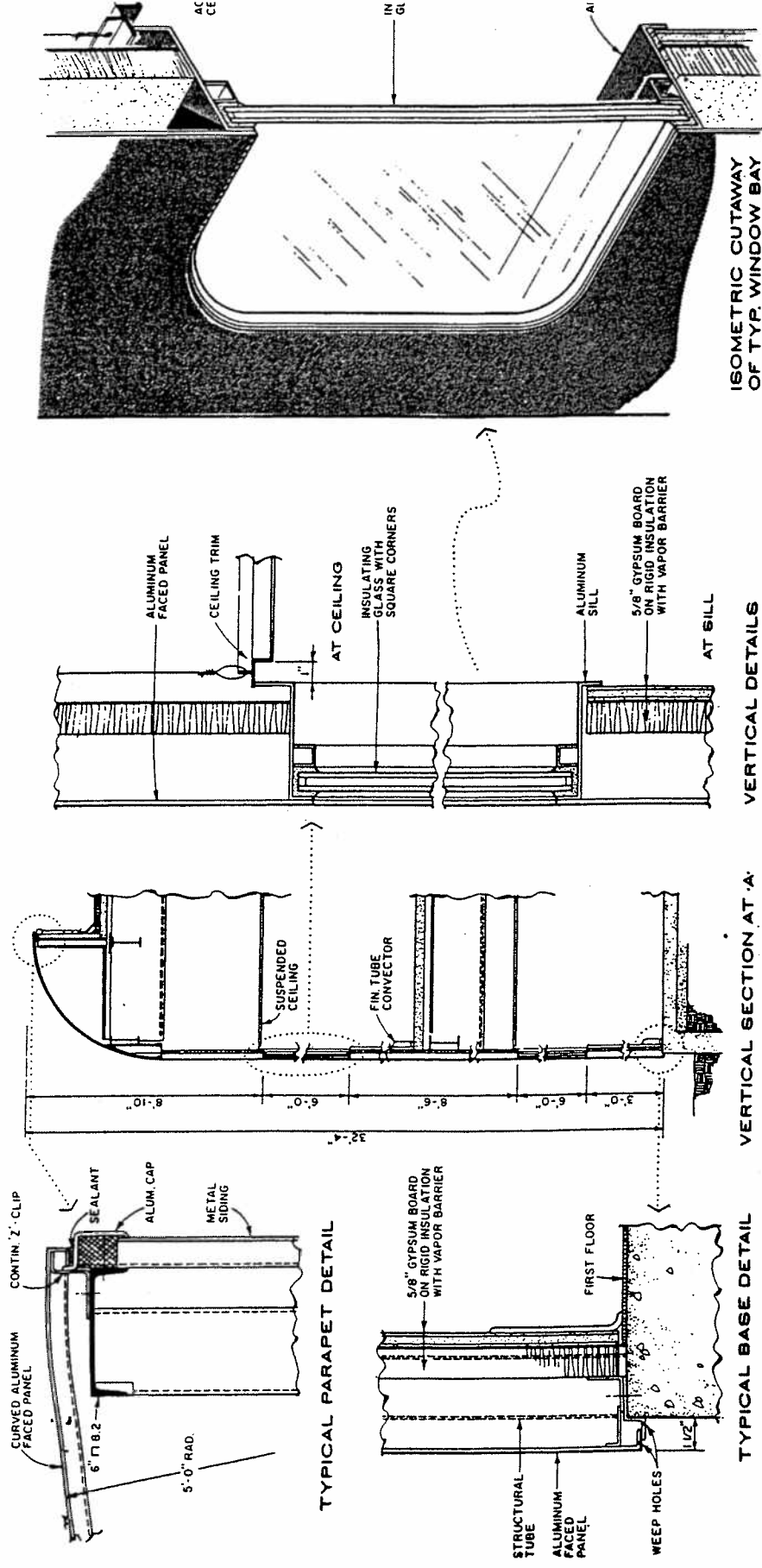



fig. 15. Photograph from the central spine through the landscape to the catwalk, COMSAT Laboratories (Cesar Pelli for DMJM architect), Clarksburg, MD, taken 2002.
Source: Mary Corbin Sies



ISOMETRIC CUTAWAY OF TYP. WINDOW BAY

VERTICAL DETAILS

VERTICAL SECTION AT 'A'

TYPICAL BASE DETAIL

TYPICAL PARAPET DETAIL

Fig. 16 - Construction details for parapet, base and wall section, COMSAT Laboratories (Cesar Pelli for DMJM architect) Clarksburg, MD, delineated 1967 Source: Cesar Pelli & Associates architects

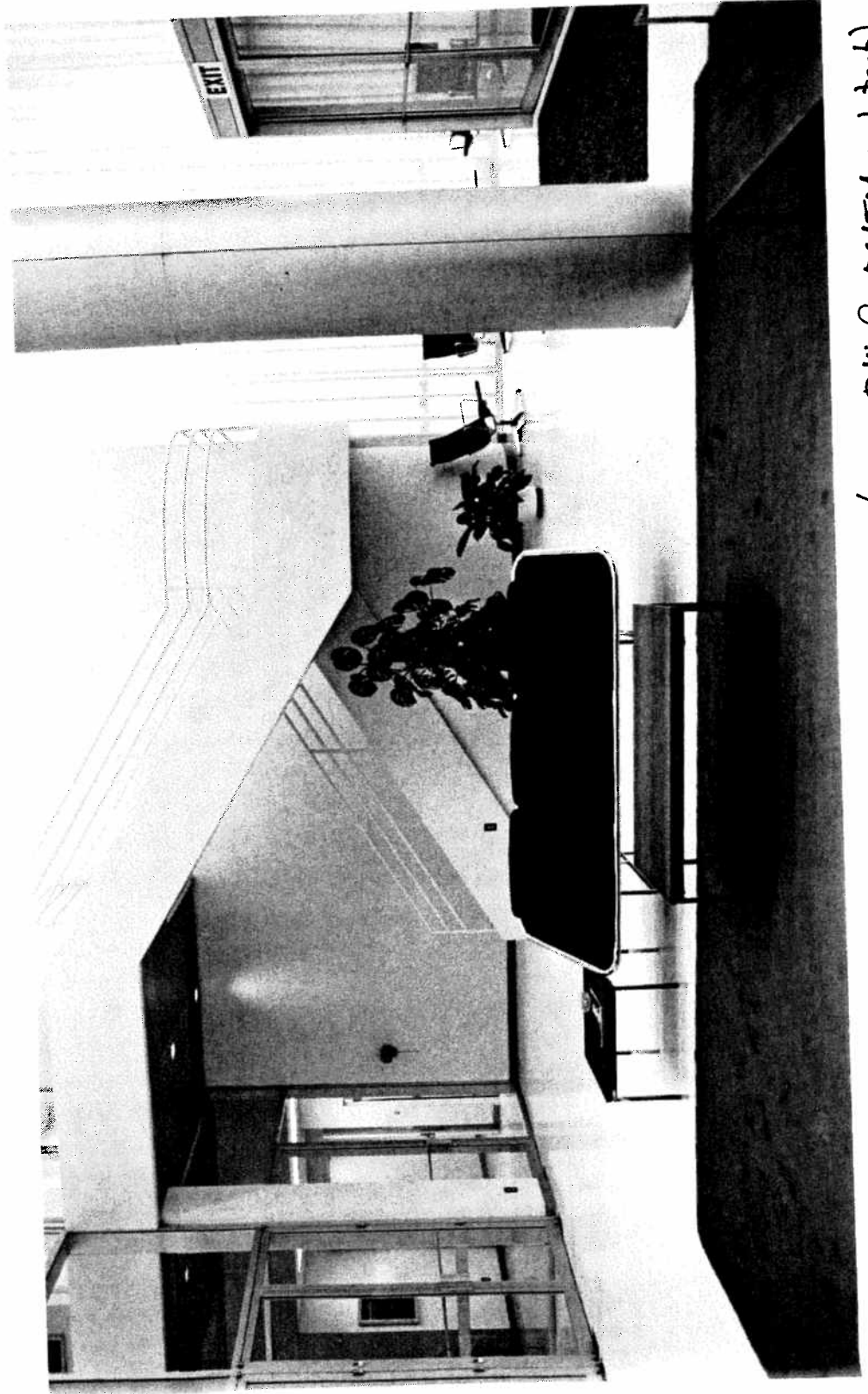
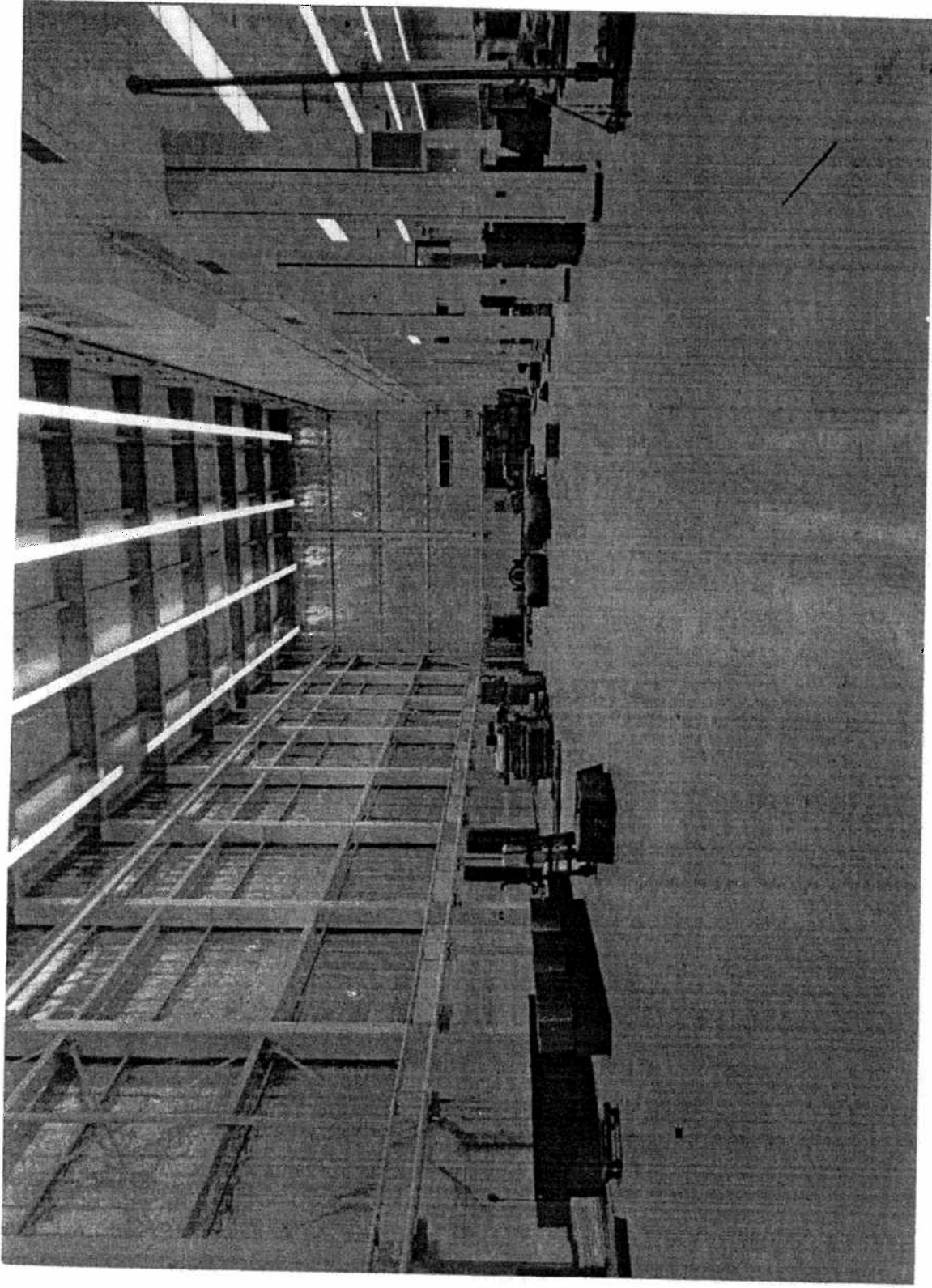

Fig. 17. Interior photograph of lobby, COMSAT Laboratories (Cesar Pelli for DHJM architect)
Clarksburg, MD, taken c. 1970 Source: Cesar Pelli & Associates Architects



COMSAT LABORATORIES
CLARKSBURG, MARYLAND
CONTRACTOR

J. W. BATESON COMPANY, INC.,
HIGH BAY AREA LOOKING SOUTH
OCTOBER 3, 1968

NO. 139

Fig. 18 - Photograph of the Environmental Test Laboratory upon completion, COMSAT Laboratories (Cesar Pelli, for DHSTH architect), Clarksburg, MD. take October 3, 1969. Source: John Gerace, Senior Facilities and Mike Smith, WOR Inc.

Fig. 19. Photograph of the exhibition pavilion and nettem facade, COMSAT LABORATORIES (see also p. 101) taken July 3, 1969. Source: John Grace, EMOOR Facilities and Mike Smith, LCOR. Imported.

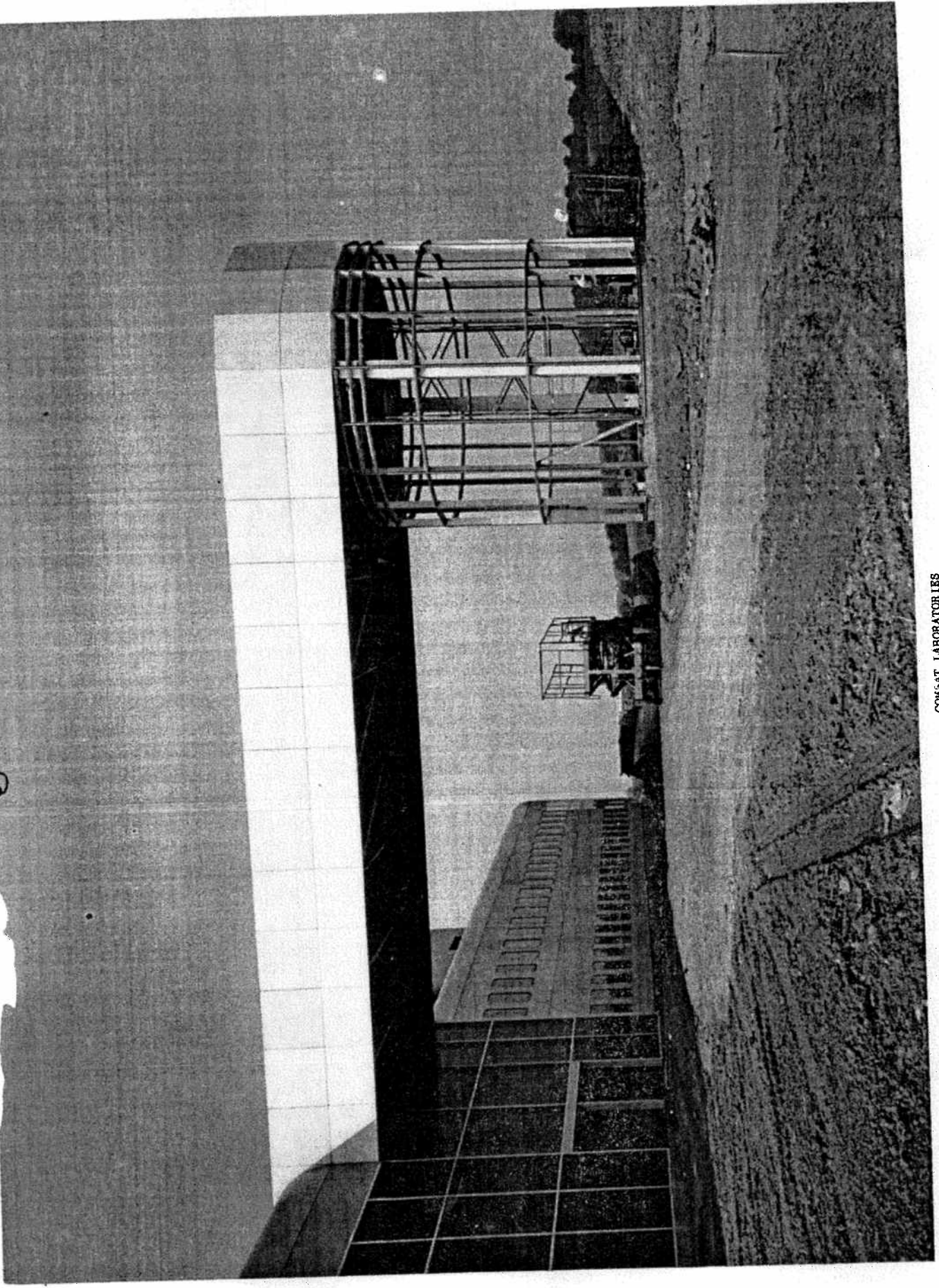

J. W. BATESON COMPANY, INC., CONTRACTOR
DISPLAY AREA
JULY 3, 1969

COMSAT LABORATORIES
CLARKSBURG, MARYLAND

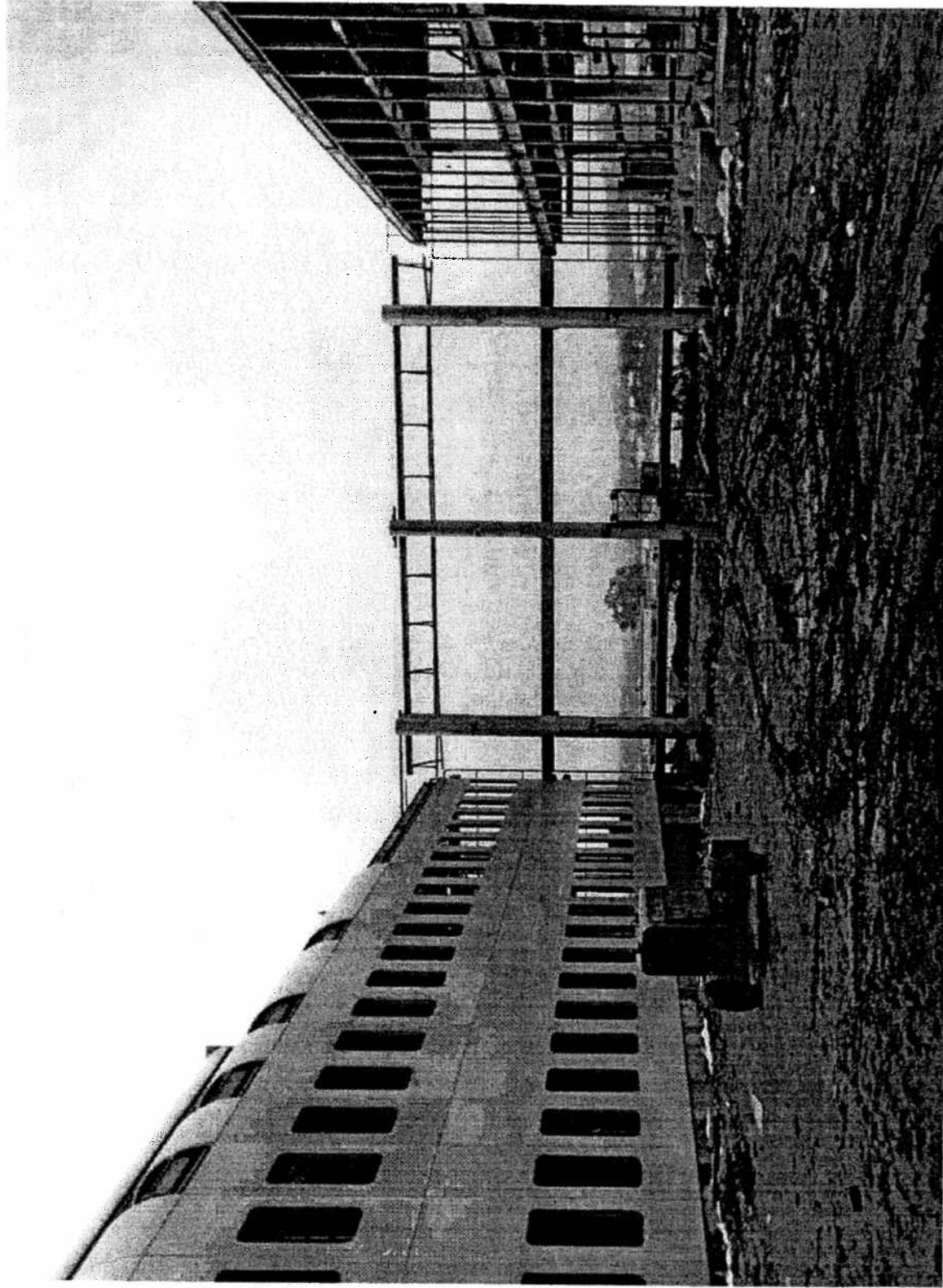

COMSAT LABORATORY
CLARKSBURG, MARYLAND
J. W. BATESON COMPANY, INC., CONTRACTOR
COURT BETWEEN WINGS 2 AND 3 LOOKING WEST
NOVEMBER 15, 1968

NO. 63

Fig. 20. Photograph of the catwalk and wings under construction, COMSAT Laboratories (Cesar Pelli for PHJM architect)
Clarksburg, MD, taken November 15, 1968, Source: John Gerace, Emcor Facilities and Mike Smith, WOR Inc.

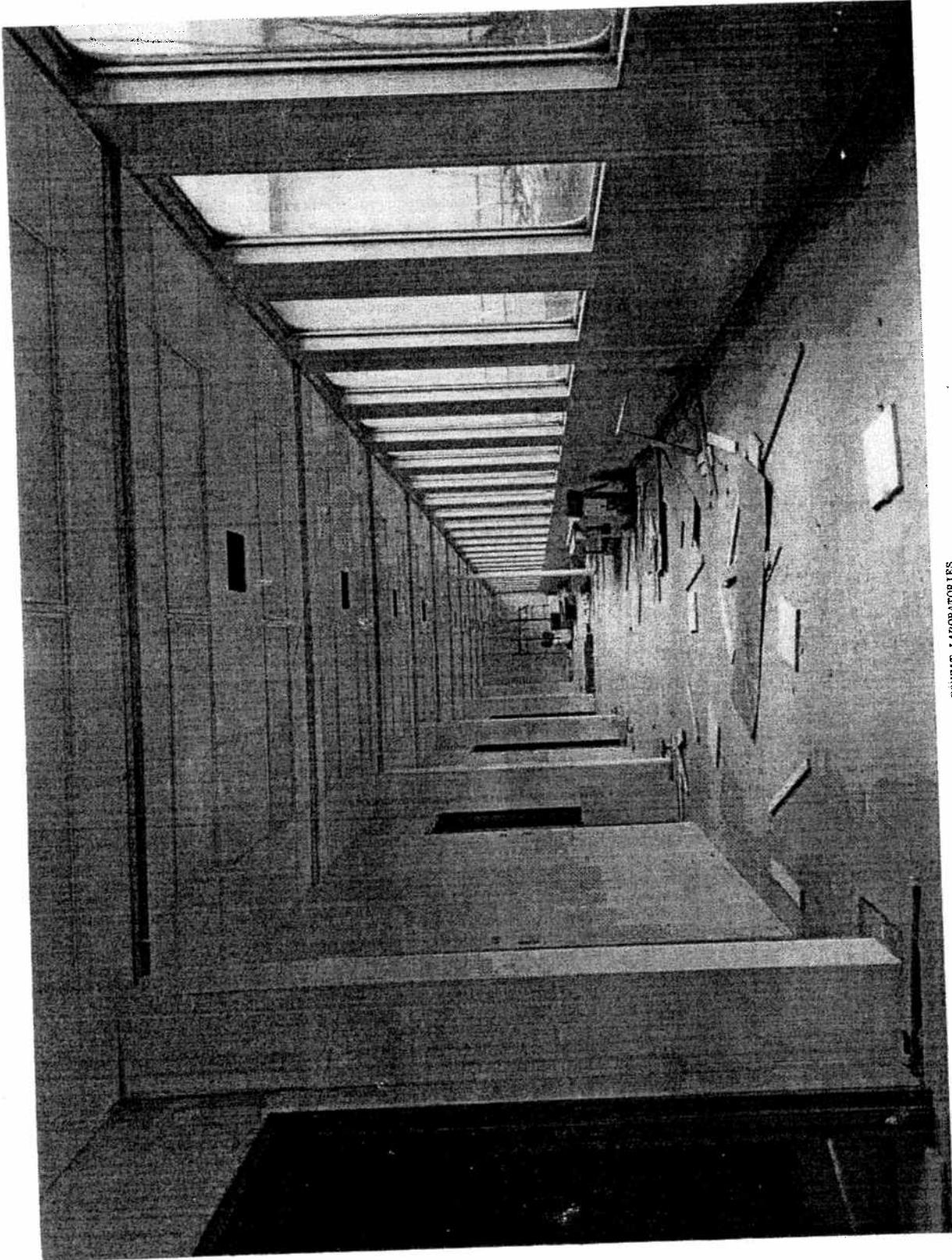

COMSAT LABORATORIES
CLARKSBURG, MARYLAND
CONTRACTOR

NO. 86

J. W. BATESON COMPANY, INC.,
WING 3, 1ST FLOOR
FEBRUARY 27, 1969

Fig. 21 Photograph of the office spaces under construction, COMSAT Laboratories (Cesar Pelli architect for DMM) Clarksburg, MD, taken February 27, 1969. Source: John Gerace, Emcor Facilities Services and Mike Smith.



Fig. 22. President Kennedy signing the Communications Satellite Act in August 1962 that established COMSAT
Source: www.COMSAT-legacy.org

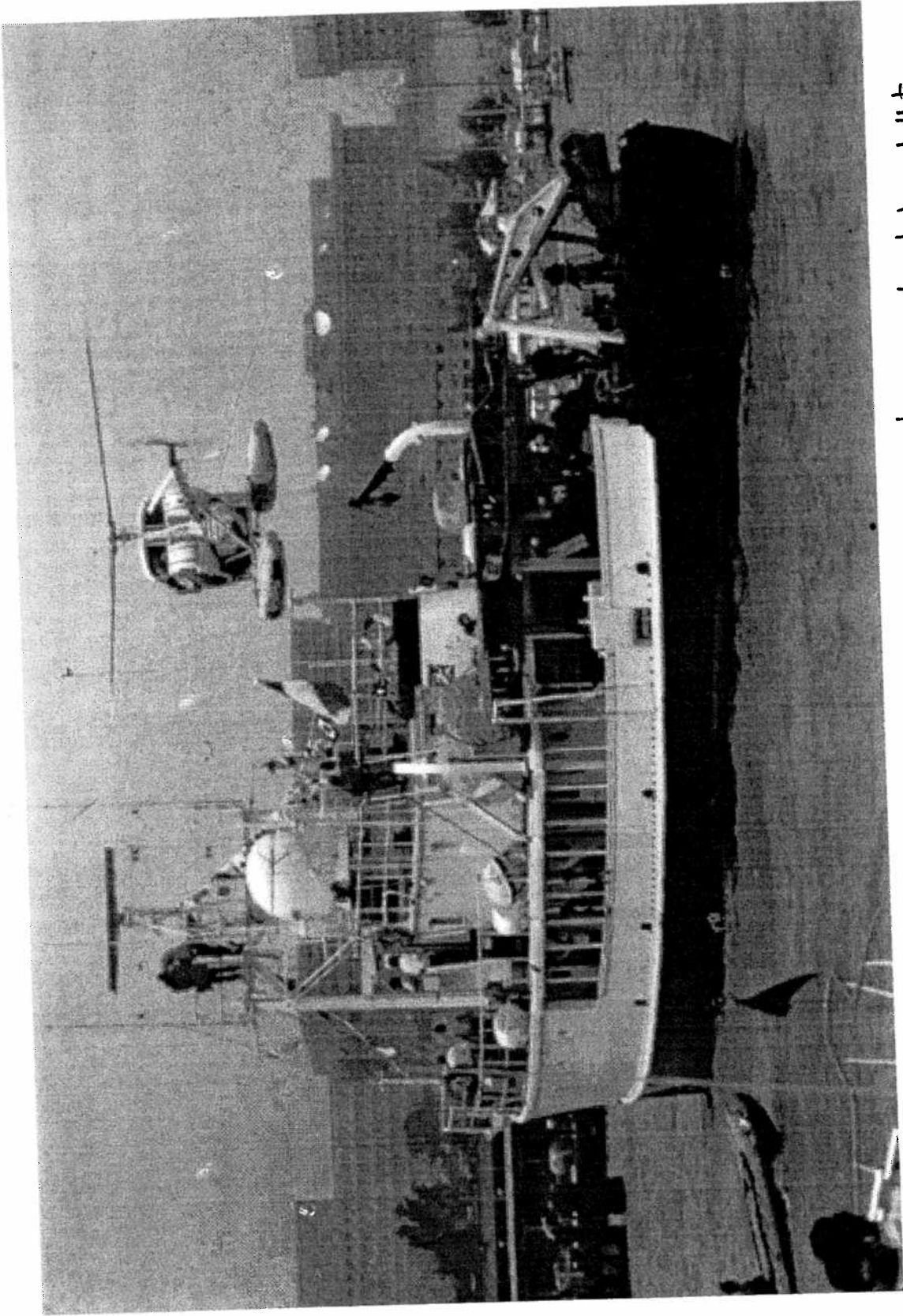

Fig. 23. Photograph of the "Calypso", Jacques Cousteau's boat. Cousteau used mobile satellites developed by COMSAT Laboratories on his voyages. Source: WWW.COMSAT-LEGACY.ORG

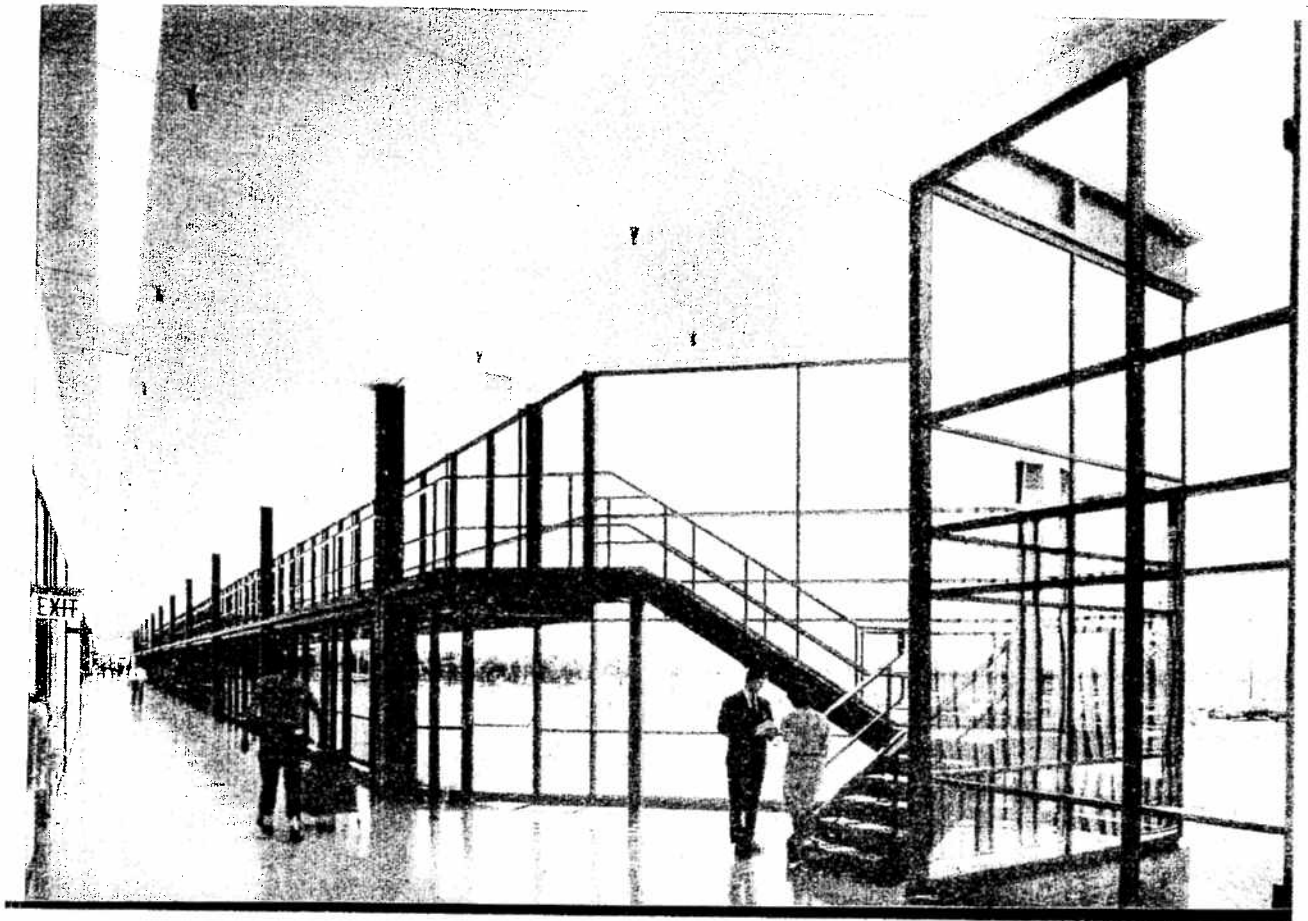
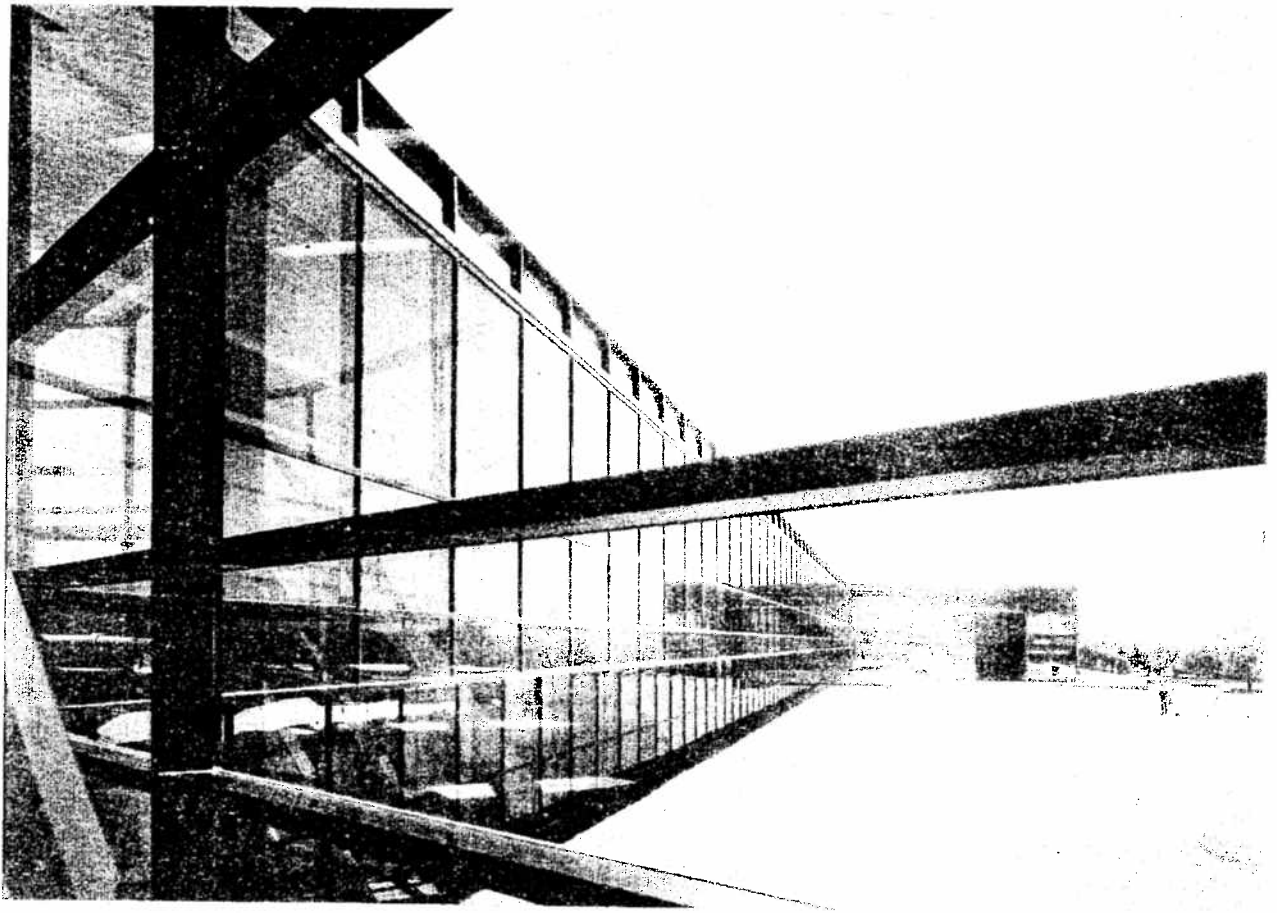
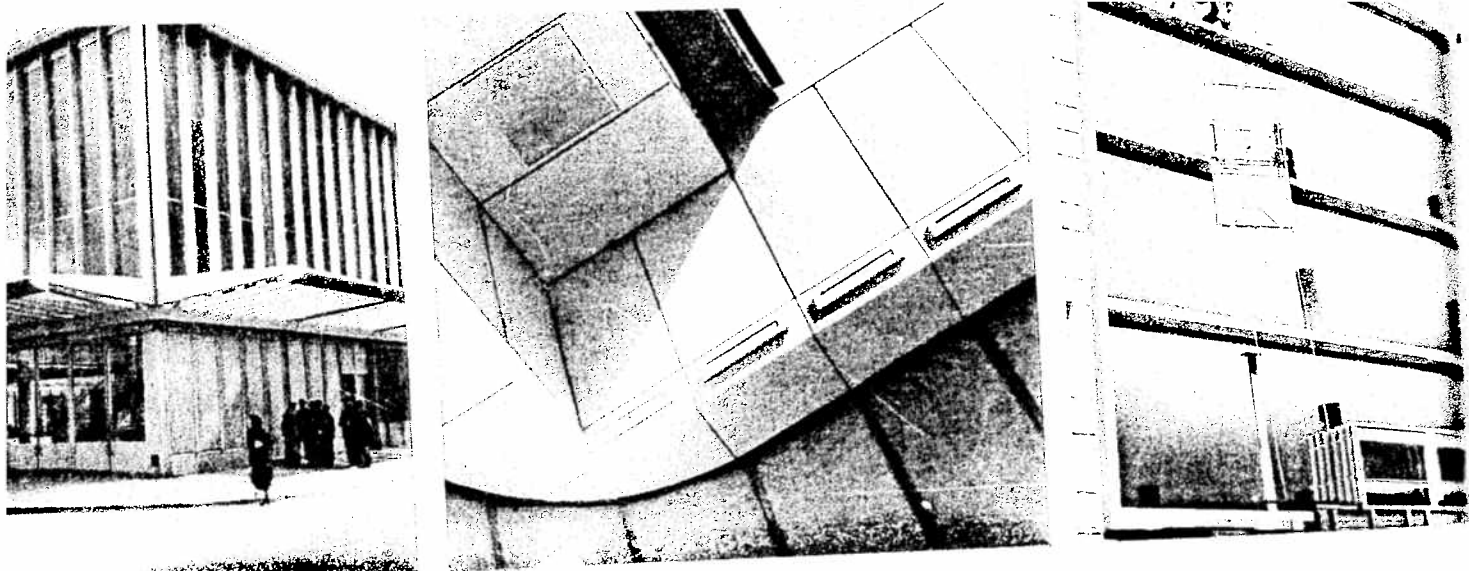

Fig. 24.—Cesar Pelli for DMJM, Teledyne Laboratories, Northridge, California, Completed 1967. Source: Architectural Forum, July-August 1968.



ÉLÉMENTS DE FAÇADE EN ALUMINIUM ÉTUDIÉS ET RÉALISÉS PAR LES ATELIERS JEAN PROUVÉ

1	2	3	4
			5
6	7	8	9

1 et 2. 1937. Le marché couvert de Clichy utilisé comme marché, salle de cinéma ; façade principale et détail intérieur montrant le toit ouvert. Beaudouin et Marcel Lods, architectes. 3 et 4. 1951. Fédération du Bâtiment de Laperouse à Paris ; mise en place des éléments de façades préfabriquées de la façade sur le jardin, Gravereaux et Lopez, architectes. 5. 1955. Habitation d'habitation, square Mozart à Paris, Lionel Mirabaud, architecte. 6. 1955. de la Foire de Lille, Paul Herbé et Maurice Gauthier, architectes. 7. 1955. Panneaux de revêtement vis de l'intérieur et de l'extérieur, études de l'ensemble d'habitation de Bron-Parilly, Grimal et Gagès, architectes, et études de le groupe d'habitation de Saint-Jean-de-Maurienne, Blanc, architecte. Préfecture de Nevers, M. Robert, Architecte.

Ces diverses études ont fait l'objet de publications dans nos précédents numéros : Le Marché couvert de Clichy, n° 3-4, 1940, page 40. Fédération du Bâtiment de Laperouse, décembre 1951, page 58, et n° 47, février 1953, page 73. Immeuble Mozart à Paris, ce numéro, page 80. Palais de la Foire de Lille, n° 35, page XXIX, et n° 38, décembre 1951, page 53.

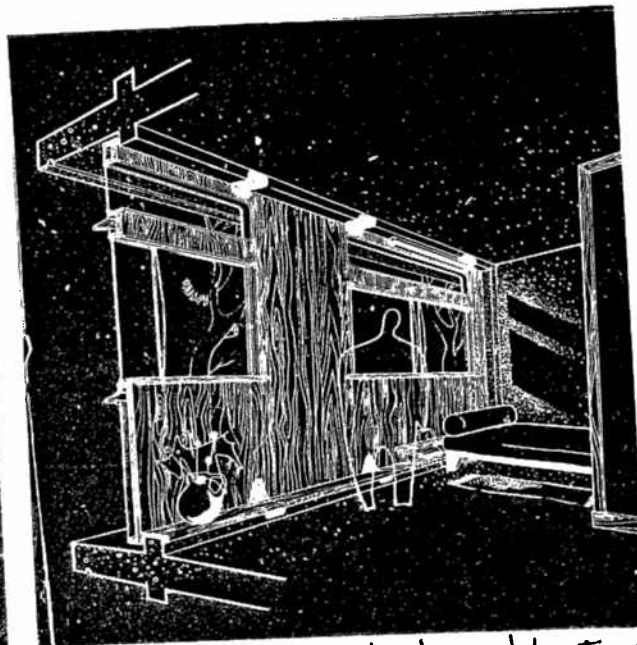
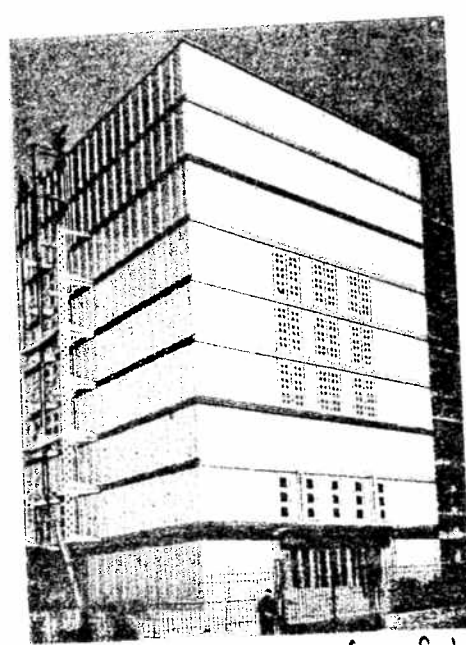

Fig. 25. Examples of prefabricated aluminum panels devised by Jean Prouvé
 Source: L'Architecture d'Aujourd'hui, February 1955

1. ENTRANCE PORCH
2. LIVING ROOM PAVILION
3. GARAGE / DRESSING ROOM /
MASTER BATH PAVILION
4. GALLERY
5. KITCHEN / SITTING ROOM PAVILION
6. DINING ROOM PAVILION
7. GUEST BEDROOM PAVILION
8. SCREEN PORCH

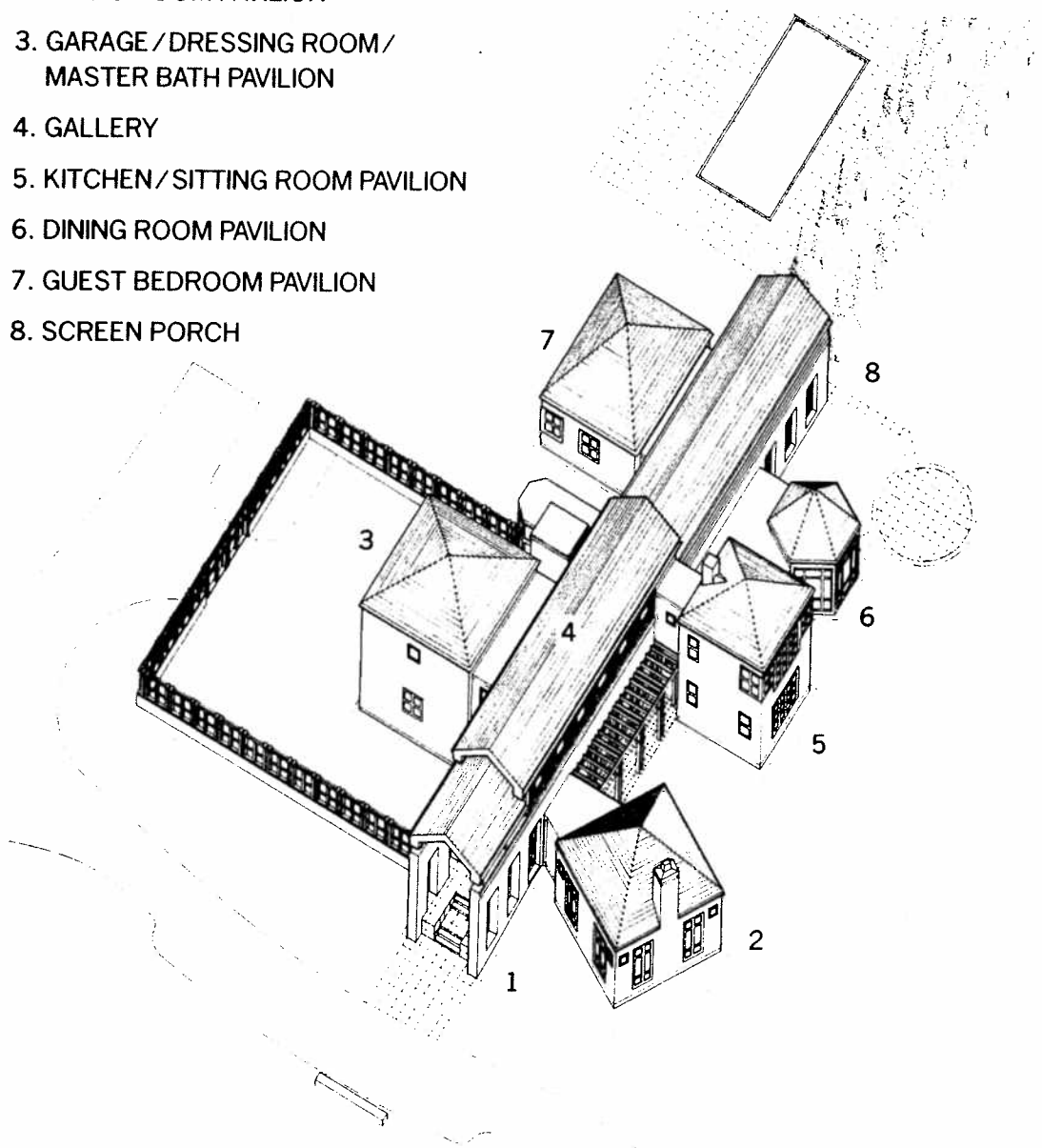

fig.26 - Axonometric view, House (Cesar Pelli architect), Montgomery County, MD, delineated c. 1986
 Source: Architectural Digest, July 1990

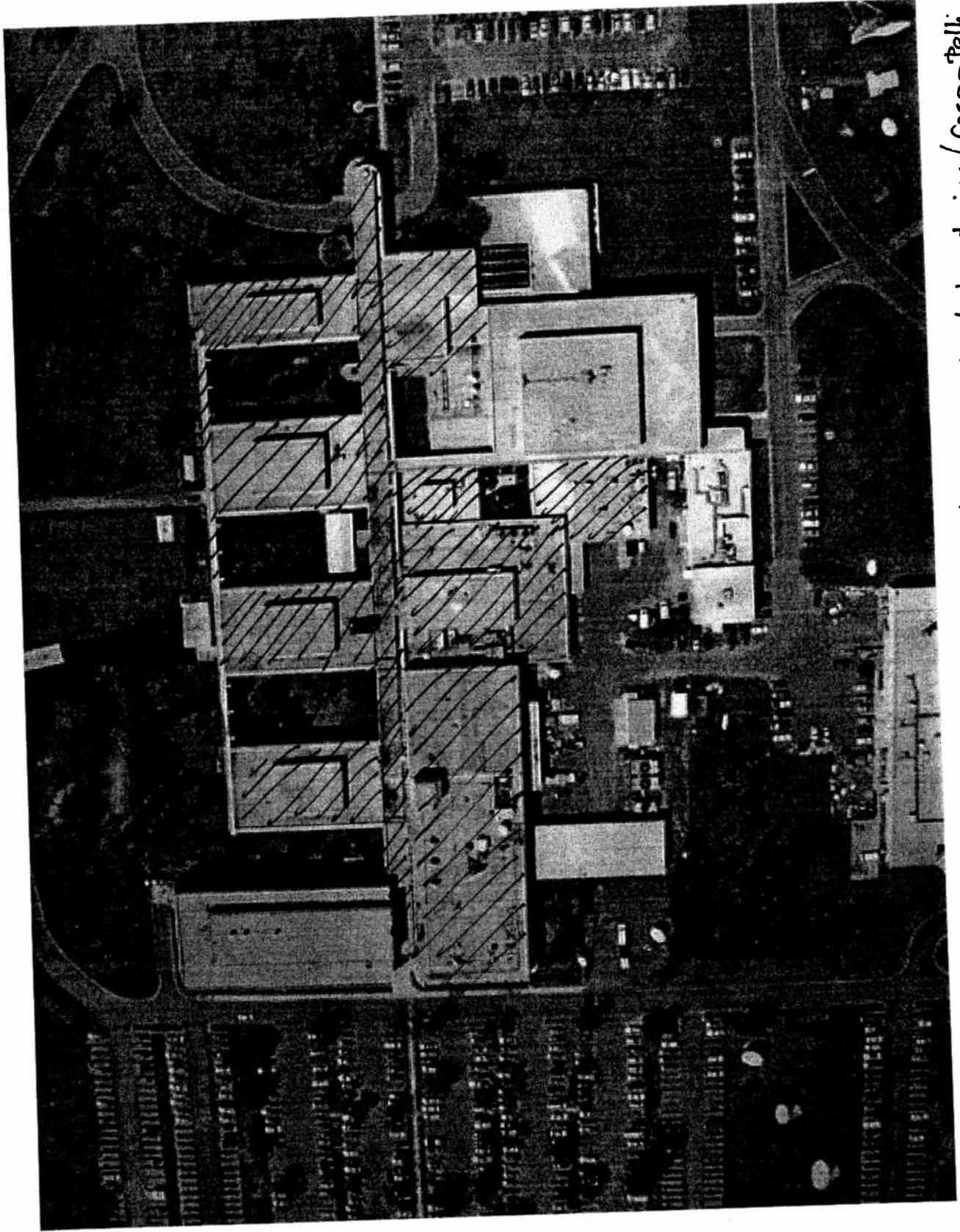

Fig. 17. Aerial view showing additions to original structure, COMSAT Laboratories (Cesar Pelli for DMJM architect) Clarksburg MD, photograph taken c. 2004 Source: www.COMSAT-Legacy.org

Attachment C: Letter from the Maryland Historical Trust

Wes Moore, Governor
Aruna Miller, Lt. Governor



Rebecca L. Flora, AICP, LEED ND / BD+C, Secretary
Elizabeth Hughes, MHT Director and
State Historic Preservation Officer

Maryland
DEPARTMENT OF PLANNING
MARYLAND HISTORICAL TRUST

September 12, 2024

Ms. Rebeccah Ballo
Historic Preservation Supervisor
Montgomery County Planning Department
2425 Reedie Drive, 13th Floor
Wheaton, MD 20902

Re: Montgomery Planning Request – COMSAT Building National Register Eligibility

Dear Ms. Ballo:

Thank you for reaching out to request assistance from the Maryland Historical Trust (MHT) regarding a determination of National Register of Historic Places eligibility for the COMSAT Laboratories at 22300 Comsat Drive, Clarksburg, MD 20871, pursuant to Title 8 of the Land Use Article, §8-205(2)b. We are responding primarily based on the draft National Register nomination you provided but would be happy to evaluate any additional information as needed.

MHT has determined that the COMSAT Laboratories building in Clarksburg (M:12-59) is eligible for listing in the National Register of Historic Places under Criterion C as the work of a master at the state level of significance. Designed by architect Cesar Pelli in 1967, the building is an early example of “High-Technology” design with many features that would come to characterize the style, particularly along Montgomery County’s technology research corridor. The COMSAT Laboratories building features aluminum cladding (contemporaneously referred to as “metal skin”) in the metal-glass based curtain walls set in a pastoral landscape, characteristics that are consistently repeated in other High-Tech designs. The building is one of four Pelli-designed buildings in the region and Pelli’s only commercial design still standing in Maryland. The building is also eligible for listing in the National Register under Criterion A in the areas of Science, Engineering, and Communications at the national level of significance. COMSAT Laboratories opened in 1969 as the research division of the COMSAT corporation, which was founded in February 1963, as a result of the Communications Satellite Act of 1962, to establish a commercial communications satellite system. The research undertaken at COMSAT Laboratories developed modern communication technology that was revolutionary at the time.

Maryland Historical Trust • 100 Community Place • Crownsville • Maryland • 21032

Tel: 410.697.9591 • toll free 877.767.6272 • TTY users: Maryland Relay • MHT.Maryland.gov

When the draft National Register documentation was prepared in 2005, COMSAT Laboratories held over 100 patents, with many more pending. Accomplishments by researchers at the building include the broadcast of the moon landing on television in 1969, the development of antennae that could be used for ship-to-ship communication, echo suppressor and echo cancellers that allowed for voice calls over satellite, videoconferencing, and the hydrogen-nickel oxide battery, which extended satellite battery power.

The proposed Period of Significance for the building extends from 1969 when construction on the building was completed through 1974. However, additional comparative research and documentation of the accomplishments of the COMSAT Laboratories may extend the period of significance beyond the fifty-year mark. Because of the significance of accomplishments of the COMSAT Laboratories, Criterion Consideration G will likely be met.

We hope this satisfies your request. If you have any additional questions, please contact Nell Ziehl, Chief of Planning, Education and Outreach, at nell.ziehl@maryland.gov or (410) 697-9592.

Sincerely,

A handwritten signature in cursive script that reads "Elizabeth Hughes". The signature is written in black ink and includes a long horizontal flourish at the end.

Elizabeth Hughes
Director

cc: Jessica French, Administrator, National Register Program

Attachment D: COMSAT Laboratories: 1985 Annual Report

COMSAT Laboratories

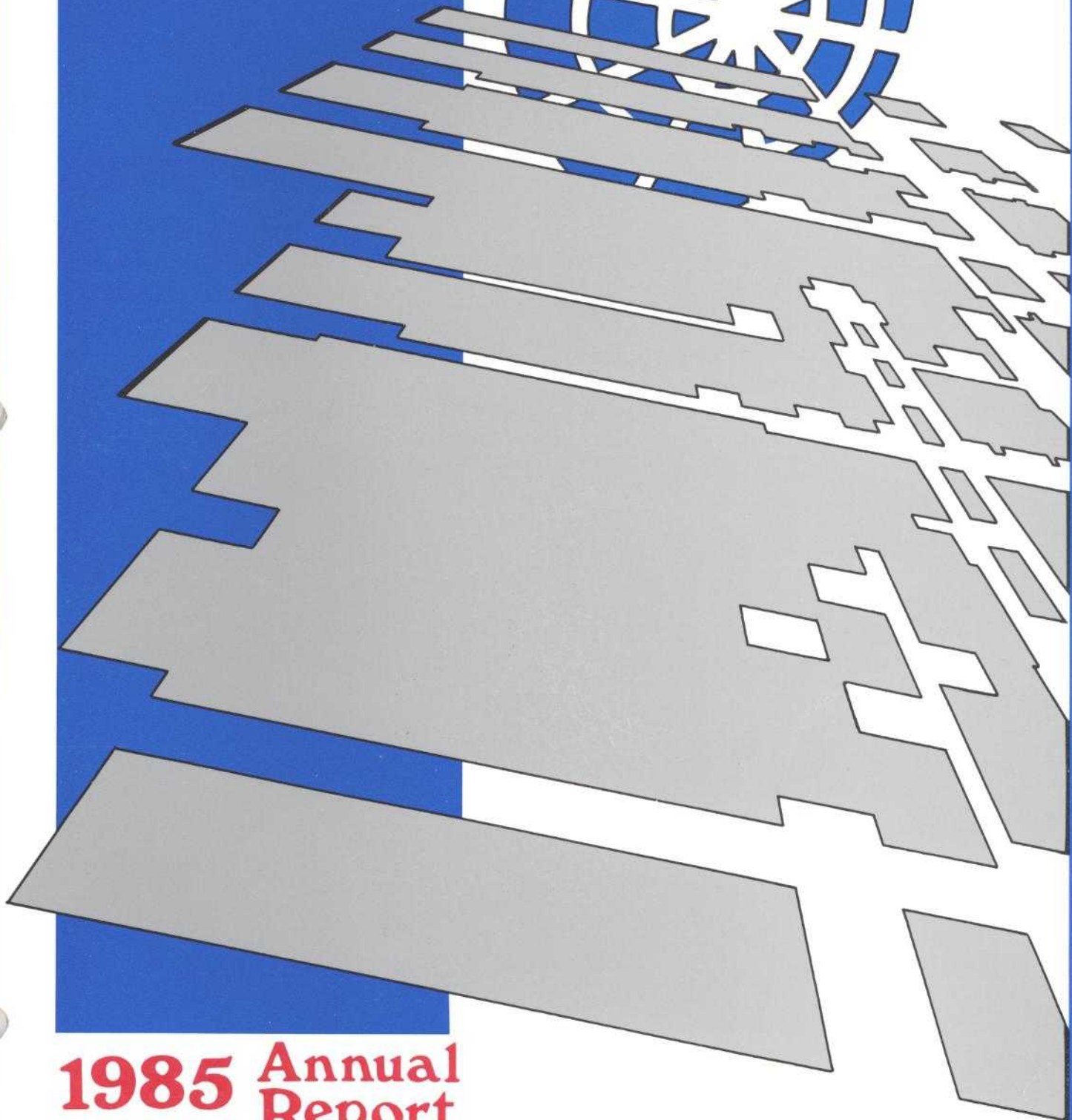
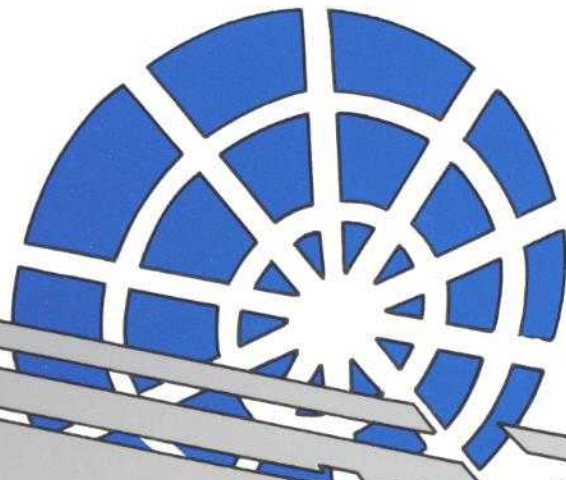

**1985 Annual
Report**

**COMSAT LABORATORIES
1985 ANNUAL REPORT**

August 1986

COMSAT Laboratories
Communications Satellite Corporation
22300 COMSAT Drive
Clarksburg, MD 20871



Comsat Laboratories conducts a program of basic research and development to advance satellite communications technology. Elements of the program are funded by the INTELSAT Satellite Services, COMSAT International Communications and Maritime Services divisions (all formerly parts of the World Systems Division), and as such are paid for from revenues derived from international communications services carried via the INTELSAT and INMARSAT organizations. Other work is funded by non-regulated components of the corporation. Documentation concerning jurisdictional work (that is, work wholly or partly funded by the rate-payer) is made available to the public through

a catalog that announces the availability of published papers and reports. In addition, a précis is published to summarize the scope of all jurisdictional projects being undertaken in each calendar year.

During 1984 the Federal Communications Commission ruled (in its Structure Order dated April 20, 1984) that the program of basic research previously funded wholly by the rate-payer must henceforth be paid for in part by the rate-payers and in part by the Corporation's shareholders. The prescribed formula that sets the ratio between these sources results in two-thirds of the cost being assigned to the shareholders. Since this work still must be put in the public domain, it affords the shareholders no proprietary advantage. The result has been a steady decrease in the overall size of the program. In 1985 the Laboratories' funding for research fell to 20 percent of its total budget (approximately \$40 million) and the balance of the effort consisted of work undertaken for Corporate and external customers approximately in the ratio 5:4. The largest effort undertaken for external customers is our involvement in the NASA Advanced Communications Technology Satellite Program (ACTS).

Commencing with calendar year 1983 we began publishing an annual report summarizing the results of our research and development program. This report provides a summary of all of the R&D work undertaken with Corporate support during 1985 and is the third in the series.

A handwritten signature in dark ink that reads "J. V. Evans". The signature is fluid and cursive.

J. V. Evans
June 1986

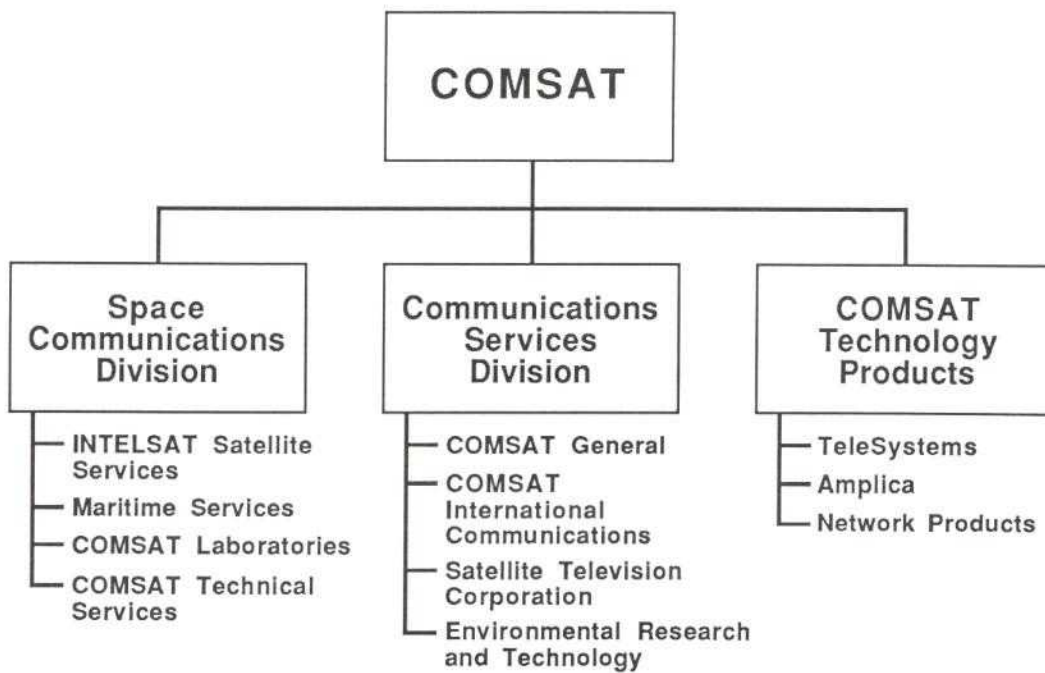

COMMUNICATIONS SATELLITE CORPORATION

Organization Circa Mid-1985

CONTENTS

This report summarizes the Laboratories' R&D activities for 1985: corporate research and support, INTELSAT support, and work funded by the Federal Government and other outside sources

1

The Network Technology Division develops satellite networks and systems that exploit satellite routing flexibility to provide new services at competitive cost. The division investigates data communications protocols and techniques for efficient data transmission via satellite, and operates and maintains small earth terminals to provide satellite access for development projects and to develop monitor and control capabilities for unattended operation

3

The Communications Techniques Division conducts exploratory investigations of communications systems and subsystems and implements and tests proof-of-concept and prototype equipment for transmissions, video, and voice-frequency band processing. The increasing use of microelectronics components has greatly extended the scope of complex systems designed and implemented with high reliability and lower cost than previously possible

9

The Microwave Technology Division performs research, development, and support functions over aspects of satellite communications that include monolithic microwave integrated circuits (MMICs) for both satellite and earth station applications, MIC and waveguide filters, on-board repeater processing techniques, satellite monitoring and in-orbit testing, new earth station and satellite antennas, propagation evaluation, and fiber and free space optical communications

23

The Microelectronics Division performs research leading to the development of state-of-the-art microelectronic components for improved and expanded satellite and other telecommunications. Efforts are directed toward improved electronics performance at higher frequencies and operating speeds, and, of particular importance to spacecraft applications, enhanced life and reliability

39

The Spacecraft Technology Division provides a broad range of engineering capabilities including controls, dynamics, propulsion, and telemetry, tracking and command, as well as structures, mechanisms, materials, thermal control, power systems, reliability and quality assurance, space environmental testing, and flight qualification. Programs are directed toward improving satellite reliability, extending satellite lifetime, and advancing communications antenna technology

55

The activities of the System Development Division encompass the development of computer-based systems including the design and implementation of software and the acquisition, installation, and integration of hardware. Other projects involve development of digital hardware and microprocessing firmware, development of analysis and simulation techniques, distributed processing systems, and establishment of standards and methodologies for software products

69

During the past year, the COMSAT ACTS Program team has actively participated as a major force in the system-level formulation of the overall ACTS architecture as well as pursuing objectives in its own area of responsibility, the NASA Ground Station/Master Control Station

75

COMSAT Laboratories publishes literature and holds patents on all aspects of satellite communications technology

81

Employees of COMSAT Laboratories received honors and awards for their work

85

INTRODUCTION

COMSAT Corporation was created in 1963 following the passage of the Communications Satellite Act, which President Kennedy signed into law in late 1962. Subsequently, in 1964, INTELSAT was established as a result of efforts by COMSAT and the U.S. State Department to facilitate international communications between fixed points by satellite. Initially, INTELSAT had 11 participants. This has since grown to 110 member countries, and the organization presently provides service to 170 nations. COMSAT is the U.S. Signatory and representative to INTELSAT.

Until 1978, COMSAT also acted as Technical Manager of INTELSAT. In this role, COMSAT encountered many technical problems, and COMSAT Laboratories was formed in 1966 to help meet these challenges. Initially located in Washington, D.C., the Laboratories moved to its present quarters in Clarksburg, Maryland, in 1969.

COMSAT Laboratories presently has a staff of approximately 480, and occupies buildings which afford approximately 400,000 square feet of space. These facilities are located on a 210-acre tract along Route I-270 north of Gaithersburg, Maryland.

In 1973, COMSAT formed the COMSAT General Corporation with the expectation of branching into domestic satellite communications. In 1975, in partnership with IBM and Aetna Casualty Co., the Satellite Business Systems Corporation was formed. In 1979, as a result of successful demonstrations, using the MARISAT system, of maritime mobile satellite communications, COMSAT and the U.S. State Department joined with other nations to form INMARSAT, for which COMSAT again serves as U.S. Signatory and representative. The Satellite Television Corporation was formed in 1980 to promote direct broadcast television. The Corporation exited from the SBS partnership in late 1984. During the first half of 1985, following an FCC order requiring the separation of the space- and earth-segment activities, the Corporation reorganized its divisions. The Laboratories, along with INTELSAT Satellite Services, the U.S. INTELSAT Signatory; Maritime Services, the U.S. INMARSAT Signatory; and COMSAT Technical Services, became the constituent parts of the Space Communications Division, while the international earth segment activities, COMSAT International Communications, Inc., are part of the Communications Services Division.

In 1985, the largest part of the work at COMSAT Laboratories remained that performed for the

regulated activity of international satellite communications, either directly for COMSAT or indirectly for INTELSAT. Additional work was performed for COMSAT General, and COMSAT's manufacturing arm—Technology Products. Effort funded entirely by sources outside of COMSAT/INTELSAT includes activities for the Federal Government (NASA or DARPA) or for commercial companies, and in particular, a significant amount of work performed on the Advanced Communications Technology Satellite (ACTS) ground segment program.

During 1985, the Laboratories was organized into six technical divisions: Communications Techniques, Microelectronics, Microwave Technology, Network Technology, Spacecraft Technology, and System Development. Of these, the first five divisions participate in a research program funded by the Corporation. This program constituted about one-third of the Laboratories' activities and includes jurisdictional (WSD) business, as well as the non-jurisdictional activities of COMSAT. The former must, perforce, be made public while the latter can be held proprietary. The balance of the Laboratories support comes from projects performed for and directed by various corporate elements, INTELSAT, INMARSAT, or other outside organizations, each of which is separately negotiated and has specified deliverables and delivery dates. The System Development Division, which is chiefly occupied in writing computer software, works almost exclusively on such specific tasks.

This report summarizes the Laboratories' R&D activities in 1985. It is organized by technology, as defined by the six technical areas represented by each of its constituent divisions. The work is further subdivided into the following categories:

- Corporate Research (Jurisdictional);
- Corporate Research (Non-Jurisdictional);
- Work performed for various COMSAT divisions in response to specific requests;
- Work performed for INTELSAT; and
- Other work.

Of these categories the most advanced work is that undertaken as part of the research program. This program is decided upon through a process of Laboratory management review of ongoing efforts and proposed new ones leading to a tentative program that is subject to critique by the WSD and the approval of COMSAT's Corporate R&D Committee—a subcommittee of the COMSAT Board of Directors.

NETWORK TECHNOLOGY DIVISION

INTRODUCTION

The focus of the Network Technology Division (NTD) is to develop satellite networks and systems that fully utilize satellite routing flexibility to provide new services at competitive cost. This concept is implemented through COMSAT's research and development program.

The NTD is responsible for research and development activities pertaining to communications network design, satellite multiple access, network control, and protocol development. The division also operates and maintains small earth terminals, both permanently mounted and transportable, to provide satellite access for COMSAT Laboratories' development projects and to develop monitor and control techniques and equipment for unattended earth terminals. In these areas of endeavor, the NTD has been engaged in systems research and development activities in support of the Corporation and its various lines of business.

Since the early 1970s, the NTD has been engaged in the development of time-division multiple-access (TDMA) systems and equipment for satellite communications. Support was provided to INTELSAT in the development of system specifications for the 120-Mbit/s TDMA/DSI (digital speech interpolation) system currently deployed in the INTELSAT global satellite network. In addition, the NTD has been actively engaged in researching data communications protocols and techniques for efficient data transmission via satellite.

In addition to hardware and system development activities, other efforts include continued enhancement of the COMSAT multiprocessor operating system (COSMOS) that was initially developed within the NTD. This software operating system, together with both single and multiprocessor hardware architectures which form the basis for most implementation tasks carried out by the division, allow common

hardware and software development for different projects.

COMSAT R&D

Non-Jurisdictional

Expert Systems

Recent developments in knowledge-based systems and expert systems hold promise for application to communications networks and their control as well as satellite systems. Currently available expert systems development environments encompass a wide range of capabilities, performance, and cost. With the use of a special-purpose LISP computer, along with the requisite software tools (including expert system shells), a concept feasibility prototype could be developed rapidly.

The required computer hardware environment was determined to be one of a number of available "LISP machines." These computers were designed using an architecture specifically developed to efficiently and effectively execute software written in the LISP programming language, which is the predominant language of artificial intelligence research and applications in the United States. The most powerful software development tools that are commercially available are compatible only with computer hardware of this category.

It was decided that NTD expert systems research and development could best be designed, applied, and supported using computer hardware of the LISP machine variety. It was also determined that the cost and delay associated with complete in-house development of the required software tools was restrictive, and would delay the implementation of useful applications. Following a detailed exploration and comparison of available LISP machines, expert systems software development tools, and the combined computer hardware and software performance, a computer and software combination was chosen and procured.

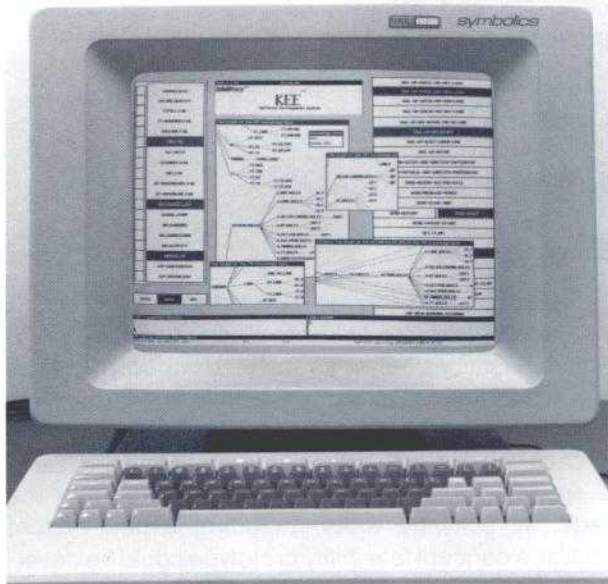

Figure 1. Expert system prototypes, such as this intelligent network-alarm management system, are developed by the NTD

Figure 1 shows an intelligent network-alarm management system, one of the expert system prototypes being developed in the NTD.

COMSAT SUPPORT

Space Communications Division

NBS/COMSAT Data Communications Experiment

Since late 1983, COMSAT and the National Bureau of Standards (NBS) have been engaged in a joint program to examine and test the performance of data communications protocols (specifically, high-level protocols) over satellite links. The first phase of the program, concluded in early 1985, focused on the normal data flow procedures of the International Standards Organization/International Telegraph and Telephone Consultative Committee (ISO/CCITT) class-4 transport protocol. The satellite experiment demonstrated satisfactory performance for computer communications via satellite transmission paths for a wide range of bit rates (32, 64, 384, and 1544 kbit/s) and bit error rates. The performance degradation of the class-4 transport protocol due to degraded bit error rate and the satellite propagation delay was shown to

be alleviated by minor modifications in the current specification of the international standard of the protocol.

The above modifications were presented to the ISO/TC97/SC6 meeting in October 1985. The working group dealing with the transport protocol approved the modifications and forwarded them to all member bodies of TC97/SC6.

The second phase of the program deals with the expedited data flow procedure, duplex and multiplexed connections, and their operation over satellite links. Modifications to the expedited data flow procedures were tested over satellite links and a considerable performance improvement was demonstrated.

The remaining functions of the transport protocol and other higher level protocols and appropriate modifications will be implemented and tested over satellite links during 1986.

T1D1 Summary

The subcommittee for Integrated Services Digital Network (ISDN), T1D1, of the American National Standards Institute (ANSI) formulates ISDN standards for the North American telecommunications system and recommends U.S. positions to international standards bodies—CCITT and ISO. The 72 voting members of T1D1 represent exchange carriers (e.g., Bell Operating Companies), interexchange carriers (e.g., AT&T and COMSAT), equipment manufacturers (e.g., IBM), and general interest representatives (e.g., FCC and NTIA).

The NTD has been actively involved in the T1D1 process to safeguard satellite interests in the evolving ISDN standards. In 1985, items considered by T1D1 included ISDN access protocols [e.g., link access procedure on D-channel (LAPD)], interworking of ISDN access protocols with common channel signaling system 7, new ISDN services, and packet mode operation of LAPD for end-to-end communication.

NTD scored a major success this year. Of particular interest to COMSAT was the "Primary Rate Access Minimal Subset" for ISDN access, the first ANSI standard completed this year by T1D1 for the U.S. ISDN environment. In formulating the standard, other carriers advocated a timer value which would have precluded the use of satellite links for ISDN access. After very difficult negotiations, NTD finally won support for a value that would ensure satellite access. It has since been incorporated into the final ANSI standard, securing COMSAT's interests for the future.



CCITT

During 1985, the NTD was involved in the activities of Study Groups VII, XI, and XVIII (ISDN matters).

For Study Group VII, a report was generated on the quality of services in public data networks. The specific parameters chosen for defining the quality of service and the range of allowable values for these parameters are important in accommodating satellite transmission paths in public data networks.

The NTD was also involved in Study Group XI activities for ISDN signaling. Various procedures and parameters for ISDN signaling protocol (D-channel protocol) were chosen to ensure its successful operation over a satellite link.

The NTD has been an active participant in Study Group XVIII (ISDN matters) to ensure that satellite circuits are not excluded from ISDN and that the full range of satellite communications capabilities are utilized. Satellite services were threatened by efforts to limit certain ISDN specifications based on low transmission delays. Nevertheless, a number of specific issues were resolved in favor of satellite communications:

- a. the Layer 1 ISDN interface timer for activation/deactivation procedure has been changed from 500 ms to 1 s to allow ISDN access via satellite;
- b. the routing procedures do not preclude two-hop satellite links; and
- c. ISDN circuits will not be categorized on the basis of transmission delays.

COMSAT Technology Products

Low-Rate TDMA

The NTD has been selected by COMSAT TeleSystems, Inc. to provide hardware and software development for the DST 2000 low-rate time-division multiple-access (LR-TDMA) system. The DST 2000 supports global and spot-beam service and as such is capable of operation both within the INTELSAT Business Services (IBS) environment and within domestic satellite systems. The system is physically compact and can be scaled to RF service between 3.0 and 20.0 Mbit/s; it utilizes quadrature phase-shift keying (QPSK) modulation and supports up to 255 TDMA terminals in the network. Network synchronization is achieved by means of centralized reference stations and network management; monitoring and control is

achieved by means of a low-cost microcomputer at a network control center co-located with, or remote from, a reference station.

The terminals support synchronous or asynchronous networking with 2.4-kbit/s minimum channel spacing. Services include preassigned, reservation, and point-to-multipoint connectivity; an optional demand-assignment capability is also available. Terrestrial interface modules (TIMs) presently include the T1 (1.544-Mbit/s) TIM and the multipoint variable rate (8.0-Mbit/s aggregate maximum) data TIM. Forward error correction is available for selected TDMA satellite channels. Fully redundant equipment configurations can accommodate high availability requirements; redundancy on the TIMs is provided in a 1-for-N manner.

The DST 2000, shown in Figure 2, is a hardware-programmable, low-cost TDMA terminal. It is implemented using COSMOS, the COMSAT multiprocessor operating system developed within the NTD. With this proprietary operating system, any process in any terminal in the network can communicate directly with any other process in any other terminal in the network. The network management system for DST 2000 is implemented using UNIX. Both terminal and network management software is written in C.

STARCOM Baseband Processor and Network Control Software

STARCOM is a satellite-based data communications system developed by the Network Products Division of CTP. The NTD has played a key role in the inception and development of this product. This program represents a significant commitment by COMSAT Laboratories to apply technology developed in the labs to solutions required for satellite data networks.

STARCOM is based on a star network topology, in which a central hub station is linked to numerous low-cost remote stations. Data are transmitted from the hub on multiple time-division multiplexed (TDM) outbound 256-kbit/s carriers, which are broadcast to all remote stations. Remote stations use multiple 56-kbit/s inbound carriers to send data to the hub; an in-bound carrier is either allocated to a specific remote station or shared by multiple stations in a random-access TDMA mode. Satellite transmission capacity is dynamically allocated based on requirements of the remote stations under an effective network management system.

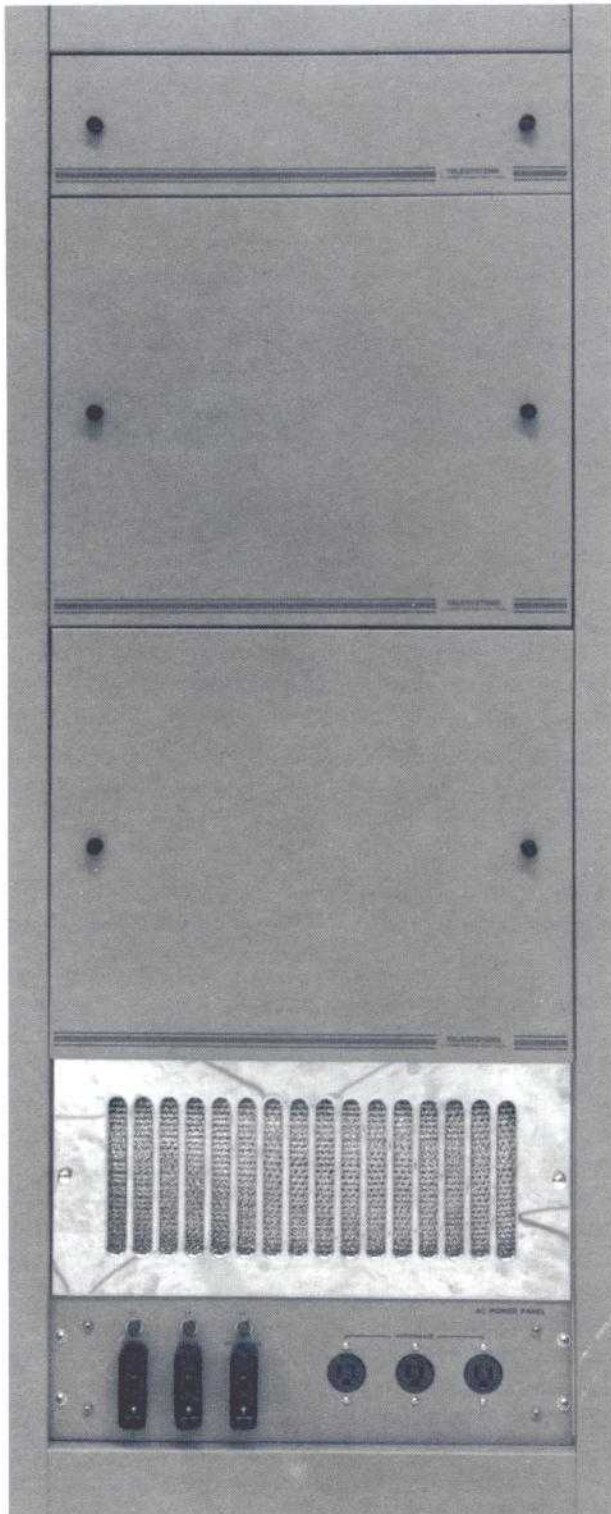

Figure 2. The hardware-programmable, low-cost DST 2000 is implemented using COSMOS, the NTD's proprietary operating system

User equipment interfaces to this network through standard interfaces. Currently, X.25 and IBM System Network Architecture (SNA) protocols are supported. Highly efficient protocols, developed in prior years at the NTD, are used over the satellite. These protocols are transparent to user protocols, but provide considerably improved performance.

The baseband processor and software technology for STARCOM was developed by the NTD in 1983 and 1984 as part of the research and development program in data communications. The software is based on the COSMOS operating system, which has been developed by NTD for use in high-speed, real-time control and data communications applications.

During 1985, the NTD continued to play a central role in systems and software development for STARCOM. Numerous new software functions were developed and integrated in an effort to assemble the first working STARCOM network. The SNA/SDLC (Synchronous Data Link Communications) and X.25 protocol implementations were completed and the communications protocol for efficient and reliable transfer over the satellite was designed and implemented. The network management subsystem was designed to monitor, control, and effectively allocate resources in the network. The network management subsystem, which resides in the hub, continuously monitors the entire network and automatically assigns extra capacity to stations that are carrying more traffic by allocating a dedicated inbound channel to the station for a temporary period. It also monitors the health of the network and down-line loads remote stations to bring them on-line.

The efforts culminated in a successful beta test at a customer site. The beta test consisted of a transportable hub and four remote stations. The user equipment consisted of IBM computers at the hub and IBM 3274 type cluster controllers and terminals at the remote stations. The user equipment intercommunicated using SNA/SDLC protocols. A clear circuit service was also demonstrated, providing 56-kbit/s dedicated synchronous channels between the hub and remote stations and between remote stations using double-hop transmission.

Communications Services Division

Traffic Configuration and Monitor System

Since 1984, the NTD has been involved in investigations of earth station management and control



systems for interconnecting terrestrial traffic to various satellite access equipment. During 1985 work continued to focus on the development of a traffic configuration and monitor system (TCMS) for COMSAT International Communications, Inc. (CICI) that would serve both small and, with incremental units, large earth stations.

The TCMS permits terrestrial traffic to be interconnected at the individual channel level with frequency division multiplex (FDM), single-channel-per-carrier (SCPC), or TDMA equipment. As such, the TCMS is an integrated communications switching controller that offers satellite/terrestrial telecommunications interfacing and switching functions. In addition, the basic architecture contains capabilities for monitoring and control of a network of such controllers from a central location.

Service capabilities of the TCMS include multiplexing and demultiplexing functions, X.25 packet data, and other future trunk services. Satellite Doppler buffering and terrestrial clock recovery functions are also provided. Additional service capabilities include digital voice compression, companding conversion (μ -law to A-law and vice versa), and video conference control. During 1985, the bus controller, which is a key element of the modular architecture of the microprocessor-based TCMS, was designed and implemented.

INTELSAT

SUPPORT

IBS Open Network Support

The NTD has continued its support of INTELSAT's Director General in the design, development, and specification of the IBS network. The IBS network is a fully digital network designed to operate with small earth stations which may be located on or near a customer's premises, and which can carry all types of telecommunications services including video, teleconferencing, high- and low-speed data, packet-switched data, electronic mail, and telex.

Two basic classes of IBS networks have been specified. The IBS closed network characteristics are based on a standardization of data rates and RF performance. The IBS open network is intended to ensure compatibility among all of its users. It extends the closed network performance characteristics to include additional features, capabilities, and detail of specification.

Prior to 1985, the NTD played an active role in the conceptual design and development of the closed network performance characteristics and the open network design. In 1985, the open network performance characteristics were refined and formulated into documents and specifications and presented to the INTELSAT Technical Committee for review and acceptance. Specific elements of the specifications included the support of the evolving ISDN recommendations by the IBS open network. The IBS open network was designed to provide services compatible with ISDN users and networks in terms of interfaces, maintainability, alarms, and other related elements.

A detailed option to prevent degraded performance of many data communications protocols when used with satellite communications media was developed, specified, and included in the accepted IBS open network performance characteristics. This capability, known as satellite delay compensation, can be used to ensure acceptable data communications performance by the users of the IBS open network.

Also, selected refinements of previously developed portions of the specifications were added. For example, a technique to provide a supervisory communications path between IBS earth stations was developed using existing transmission overhead available in IBS transmitted channels. Techniques to provide conversion among regionally supported communications standards were also developed to ensure global capability.

The NTD played an active role in the presentation and acceptance of the IBS performance characteristics by the INTELSAT Technical Committee. The IBS open network performance characteristics were finalized at the fifty-fourth meeting of the INTELSAT Technical Committee and subsequently approved for immediate implementation at the June 1985 meeting of the INTELSAT Board of Governors.

COMMUNICATIONS TECHNIQUES DIVISION

INTRODUCTION

The work of the Communications Techniques Division ranges from exploratory investigations of communications systems and subsystems to the implementation and testing of proof-of-concept and prototype equipment for transmissions processing, video processing, and voice-frequency band processing. The advent of microelectronics components such as special purpose large-scale integration (LSI) chips and very large-scale integration (VLSI) chips has greatly extended the possibilities for the design and implementation of complex systems, providing high reliability at a potentially lower cost than previously possible. Examples of such development in 1985 include a variable low-rate time-division multiple-access (LR-TDMA) modem and forward error correction (FEC) codec, an adaptive equalizer for 120-Mbit/s TDMA, low-rate digital speech encoding, and on-board digital transmission processing.

Other significant projects in 1985 involved work toward major advances in communications system techniques to improve spectral and power efficiency of satellite transmission. These efforts to meet future international needs included coded 8-ary phase-shift keying (COPSK) modulation systems, a modified National Television System Committee (NTSC) television transmit/receive processor, and a time-multiplexed television transmission method. In addition, laboratory simulations and field measurements contributed significantly to improved understanding of the performance of 120-Mbit/s TDMA with digital speech interpolation (DSI), compressed television for transmission to small shipboard antennas, and companded single-sideband (CSSB) modulation performance in a co-channel interference environment.

Finally, in an effort to reduce end-to-end international communications satellite system costs, concepts for advanced satellite system architectures have been investigated.

COMSAT R&D

Jurisdictional — INTELSAT Related

140-Mbit/s COPSK Modem Development

The performance of the rate 7/9 COPSK modulation system was investigated and evaluated by computer analysis and simulation in 1984. This system hardware is now being implemented for sending information at 140 Mbit/s over a single 80-MHz INTELSAT transponder. With this technique, four INTELSAT 80-MHz transponders can restore the entire transatlantic telephone, version 8 (TAT-8) fiber optical cable. In addition, 140-Mbit/s trunking service for the Integrated Services Digital Network (ISDN) can be provided over a single INTELSAT 80-MHz transponder.

To achieve the 140-Mbit/s information rate over the 80-MHz INTELSAT channel, the uncoded 8-ary PSK modem must operate at 180 Mbit/s. Integral parts of the 8-ary PSK modulation system are the rate 7/9 convolutional encoder at the transmit end along with a 16-state Viterbi algorithm decoder which is used in conjunction with an 8-ary PSK demodulator at the receiver end to reproduce the data stream sent over the channel.

During the past year, a breadboard of such a modem was fabricated. Figure 1 shows the results of initial performance measurements. Also initiated in 1985, implementation of the high-speed, rate 7/9, 16-state Viterbi codec is crucial to the overall combined modulation and coding system. Completion of the equipment development phase of the project is expected in 1986.

Adaptive Equalizer Development

In 1985, the final construction and testing of an adaptive equalizer for use with 120-Mbit/s TDMA was completed. This equalizer, which can improve system performance and simplify link equalization, has the ability to compensate for amplitude and group

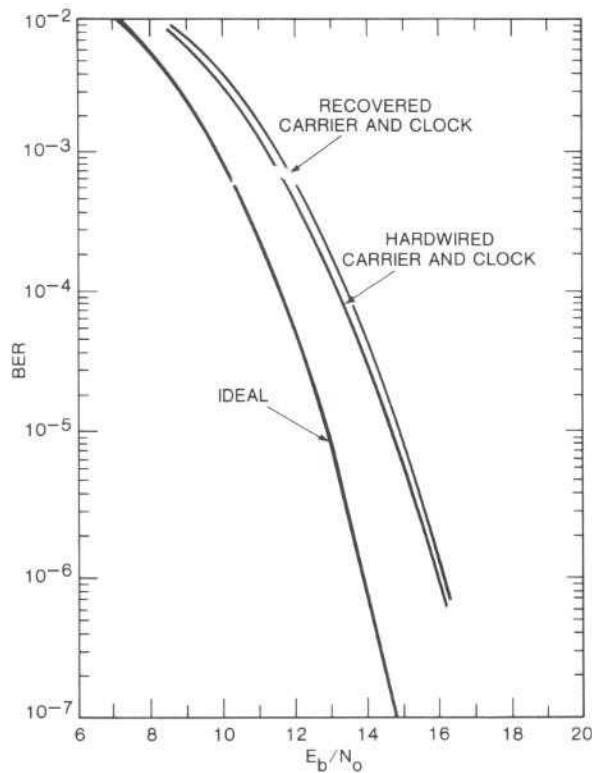

Figure 1. COPSK modem performance

delay distortions typically encountered in earth station and satellite environments. Analysis of on-line data provides channel distortion information so that equalization can be carried out without interruption of traffic. The equalizer functions in a burst mode,

thereby providing individualized equalization for each burst, which is especially significant for future systems which may employ transponder hopping.

The equalizer was designed to be inserted into the current 120-Mbit/s INTELSAT TDMA system with a minimum impact on the existing system hardware. It performs equalization at IF just prior to demodulation, as shown in Figure 2. (A manually controlled transversal equalizer is currently in place in the U.S. TDMA traffic terminal). For operation, it requires that the baseband signals and clock be taken from the modem. In addition, timing signals, which consist of a start-of-frame and start-of-burst pulse, are needed as inputs from the present TDMA terminal.

Equalizer performance was determined by inserting known amplitude and group delay distortions in both linear and nonlinear channel test setups, and measuring bit error rate (BER) with and without the adaptive equalizer. Figure 3 displays the results of one such measurement taken over a linear channel with 12 ns of linear group delay across the 72-MHz bandwidth. This figure, which also shows the modem IF loopback performance without distortion and the INTELSAT linear channel specifications, indicates that the equalizer is capable of bringing performance back to within specification for distortion of this magnitude and type. Measurements taken in a nonlinear channel show improvements similar to those of Figure 3 when the distortion is added to the down-link. For the up-link, the amount of improvement varied with the type of distortion and the degree of nonlinearity.

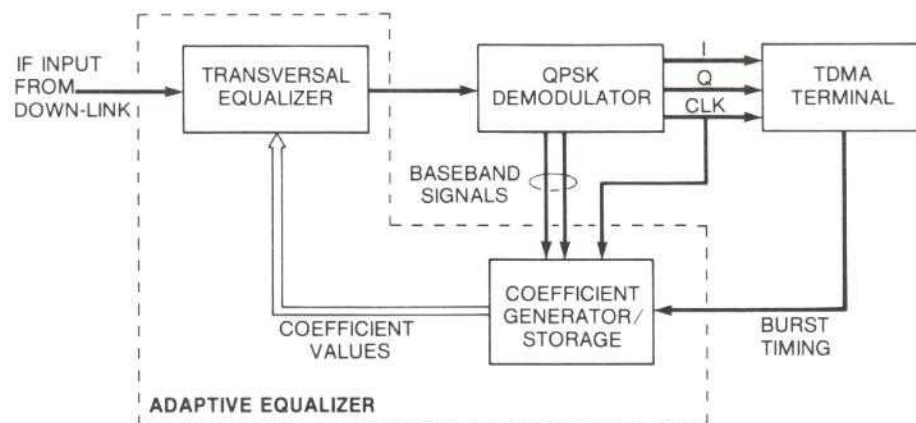

Figure 2. Adaptive equalizer for the TDMA down-link improves system performance and simplifies link equalization

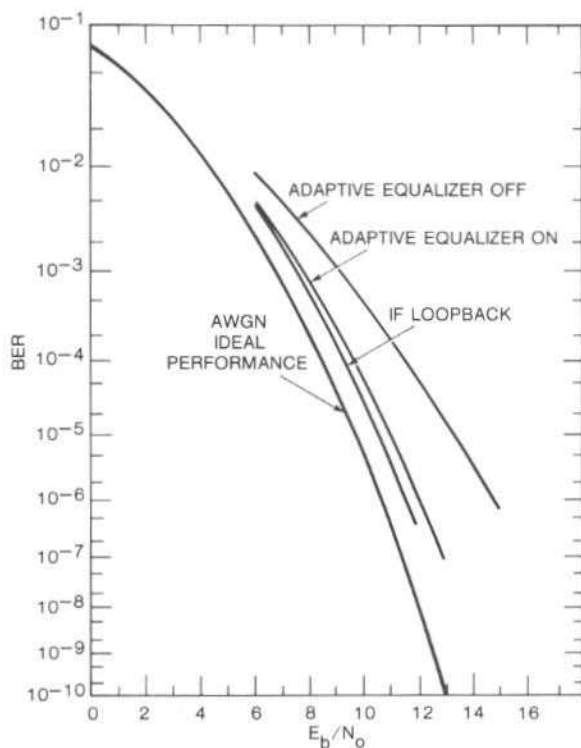

Figure 3. Adaptive equalizer performance

In the operational TDMA system, differences in up-link equalization such as variation in modem filter characteristics may cause the coefficients required for each burst to vary. The down-link characteristics for each burst may also vary when transponder hopping is employed. A microprocessor controller has been designed and tested which stores the coefficients for up to 64 bursts in a 2-ms frame and loads the transversal equalizer with the proper coefficients for the upcoming burst. The coefficient memory is updated at the rate of one burst per frame, based on information obtained during that burst from the adaptive equalizer. Measurements comparing the continuous and burst mode show nearly identical BER performance.

16-kbit/s Low-Rate Encoded Voice

This ongoing research effort intends to develop codecs that achieve toll-quality speech at a transmission rate of 16 kbit/s. At present, for toll-quality transmission, speech is encoded using 64-kbit/s pulse code modulation (PCM) or 32-kbit/s adaptive differential PCM (ADPCM). The approach being pursued is based on waveform coding of speech, particularly

using ADPCM codecs similar to those at 32 kbit/s. The lower bit rate is achieved by removing a greater amount of redundancy from the speech signals with sophisticated predictors which adapt to the speech characteristics more rapidly than predictors used previously. In addition to removing the short-term redundancy as in conventional ADPCM, long-term redundancy caused by pitch periodicity can also be removed, resulting in more efficient coding.

An experimental 16-kbit/s codec was developed based on a more rapidly adapting predictor known as the lattice structure. This codec was simulated in 1985 and its performance was studied by objective segmental signal-to-noise ratio (S/N) measurements as well as informal listening tests. The performance observed was superior to that of the conventional 16-kbit/s ADPCM codec and compared well with an experimental codec based on sub-band coding.

Even though the codec improved 16-kbit/s performance, toll quality speech was not achievable using the short-term predictor alone. Hence, the codec is being further enhanced by adding a second long-term predictor, which is in its early stages of simulation. Preliminary tests indicate that long-term prediction is indeed effective in achieving further improvement in voice quality.

Modified NTSC Video Transmission

The vast majority of satellite video communications employ analog frequency modulation (FM) techniques based on well-established technologies. Modifications to NTSC video transmission methods for FM satellite communications links are directed toward providing a simple, low-cost, baseband processing technique which improves both objective and subjective video performance over that of standard NTSC transmission and provides additional audio and data transmission capability. The performance improvements which result may also be translated into power and bandwidth savings.

As described in the *1984 Annual Report*, the feasibility of modifying the signal transmitted over the satellite was investigated using hardwired synchronization. During 1985, a prototype modified NTSC transmit/receive processor was constructed. This low-cost unit provides improved video and synchronization performance as well as a 1.8-Mbit/s one-way digital channel in the horizontal blanking interval. This data channel can be divided, as desired, in any fraction between program audio and other data services. Figure 4 shows the receiver hardware.

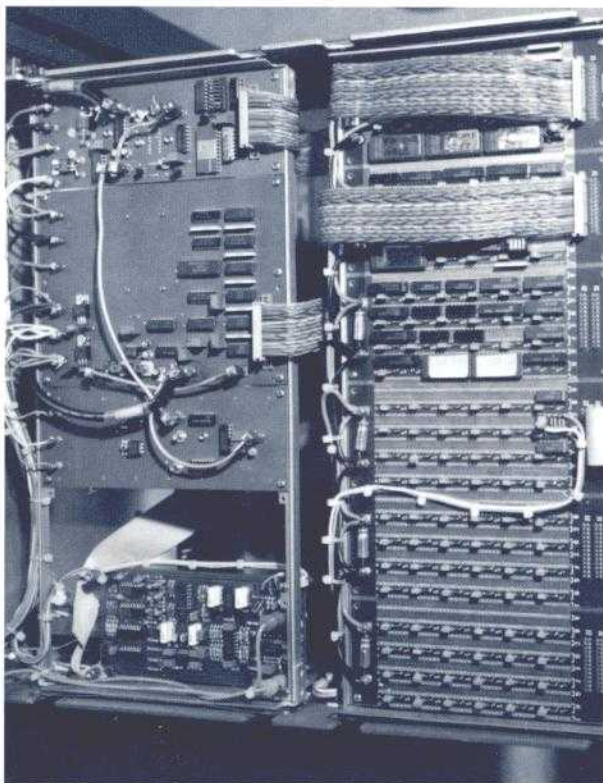

Figure 4. NTSC receiver hardware

Test results indicated a 2- to 3-dB improvement in objective video S/N relative to that of a standard NTSC video link operating in accordance with International Radio Consultative Committee (CCIR) standards. The system also demonstrated impressive improvement in subjective video performance at a low carrier-to-noise ratio (C/N).

In the prototype unit, a delta modulation codec at 220 kbit/s provides high-quality program audio. Up to eight channels can be accommodated. An optional rate 1/4 FEC and an interleaver are also included in the prototype for enhanced operation at low C/N. With coding enabled, the data channel provides two channels of high-quality program audio at a C/N down to 6 dB. Synchronization is extremely robust. The receiver remains synchronized at -3 -dB C/N and will acquire synchronization at -2 -dB C/N. This prototype unit successfully demonstrated that synchronization overhead can be reduced in the NTSC format while simultaneously achieving improved video quality and synchronization performance with a digital channel capacity close to 2 Mbit/s.

On-Board Digital Transmission Processing

On-board processing can provide additional system margins to lower the cost of earth stations and to enhance satellite capacity. With multibeam satellites, on-board baseband switching also allows efficient interconnectivity.

An on-board digital demultiplexer/demodulator that processes frequency-multiplexed carriers of mixed sizes and modulation types was studied. Two viable alternatives emerged in addition to the straightforward filtering and demodulation technique. The first method involves block demultiplexing all channels, while the second consists of a channel-by-channel demultiplexing approach. Different algorithms and architectures were investigated to determine their suitability for the on-board processing requirements. The effect of quantization and finite precision arithmetic on the overall performance was analyzed, but a more accurate assessment requires detailed simulation study, which is planned for 1986. Definition and evaluation of a base-line on-board demultiplexer/demodulator with breadboard circuit designs of critical components will be initiated in 1986.

Video Transmission Processing

Currently the most efficient television (TV) transmission standard in the INTELSAT system consists of two TV carrier signals per 36-MHz transponder in a frequency-division multiple-access (FDMA)/FM mode, which is referred to as half-transponder TV. With this type of transmission, the transponder is typically operated with 2-dB output backoff to reduce intermodulation and other nonlinear distortions, including crosstalk effects. To improve transmission efficiency, the development of a time-multiplexed analog television (TMATV) transmission scheme was initiated in 1984.

The TMATV system is designed to allow transmission of three frequency-modulated broadcast-quality TV signals through a single 36-MHz transponder in a multipoint-to-multipoint TDMA mode. Besides improved efficiency in spectrum utilization, the received signals are free from intelligible crosstalk and other undesirable distortions inherent to FDMA/FM operation. The TMATV system also incorporates a digital channel capable of carrying more than two high-quality audio programs per video channel.

The TMATV processes the video image within a video frame to reduce the signal bandwidth for transmission. At the transmit end, the signal first passes



through a spatial and temporal filter and is then time-compressed on a frame-by-frame basis before transmission. At the receiving end, the signal is interpolated and time-expanded. A field store is used for each TV channel at both the transmit and receive ends.

Computer simulations using standard test pictures (Figure 5) demonstrated the feasibility of the spatial and temporal filtering and interpolation processes. Proof-of-concept transmit and receive processors are currently under development. This technique for broadcast quality TV transmission could evolve as a near-term, low-cost alternative to digital TV for the INTELSAT system.

Future Satellite System Study

In 1985 a system study was initiated to define future satellite systems which could compete economically with fiber-optic systems for the provision of international services. A number of system architectures were examined and compared on a cost basis with the TAT-8 and other even more advanced fiber-optic systems. To remain competitive with transoceanic cables, systems which fully exploit the unique characteristics of satellites need to be developed. For example, satellites offer point-to-multipoint communications and direct interconnection of end users without long terrestrial links, capabilities unavailable with transoceanic cables.

Implementation of this type of satellite system will likely draw upon technologies such as on-board processing, multibeam antennas, digital transmission and encoding techniques, and possibly even inter-satellite links.

Multibeam satellites can reduce earth station costs. For example, Figure 6 shows that a multibeam satellite with 1° spot beams can provide satellite antenna beams with extremely high gain on the links to earth stations, enabling the use of smaller antennas and smaller high-power amplifiers (HPAs) at the earth station and thereby decreasing costs.

Beam interconnectivity on multibeam satellites may be achieved using on-board processing with baseband switching. Each carrier, regardless of size (bit rate), is demodulated on-board the satellite with all interconnection and switching done at baseband, i.e., at the channel or higher multiplexed level. Such on-board demodulation and remodulation isolates uplinks and down-links, resulting in link improvements which can be used to reduce earth station antenna size and hence cost.



(a) Original



(b) Processed

Figure 5. Spatial-temporal filtering and interpolation provides more efficient broadcast-quality TV transmission

On-board processing also permits earth stations to operate in an FDMA mode, with a single transmit carrier per earth station. This allows the earth station's HPA to be sized proportionally to the amount of traffic carried by the station rather than by the maximum bit rate of the transmission system, leading to additional earth station savings, especially for medium- and thin-route communications links.

On-board processing can include demultiplexing and remultiplexing (baseband formatting) of the satellite baseband channels for retransmission back to the receiving earth stations. All traffic destined for transmission via a given down-link beam can be multiplexed onto a single down-link carrier, thereby providing the traffic to each earth station destination in a time-division multiplex (TDM) format. This results in reduced on-board power and additional savings in earth station antenna size because intermodulation

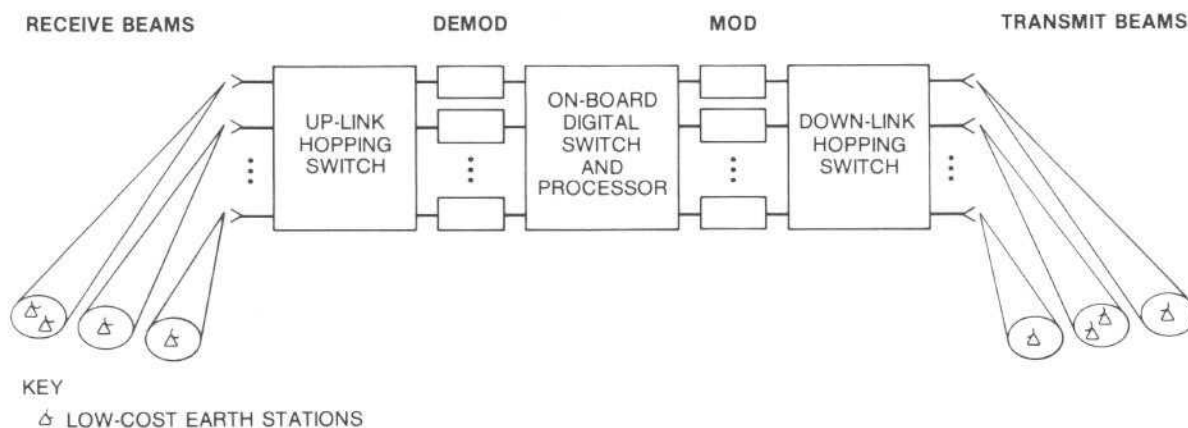

Figure 6. Multibeam satellite with baseband processing reduces earth station costs

noise is eliminated by the single-carrier-per-power-amplifier operation. Additionally, earth station communications hardware is simplified by eliminating the need for multiple down-chains and demodulators.

The study conducted during the past year has examined the cost benefits of employing this type of satellite system in the INTELSAT network. Significant savings can be envisaged in the earth station costs.

Jurisdictional — INMARSAT Related

FM Voice Channel Monitor System

Figure 7 shows the FM voice channel monitor system implemented at COMSAT Laboratories and

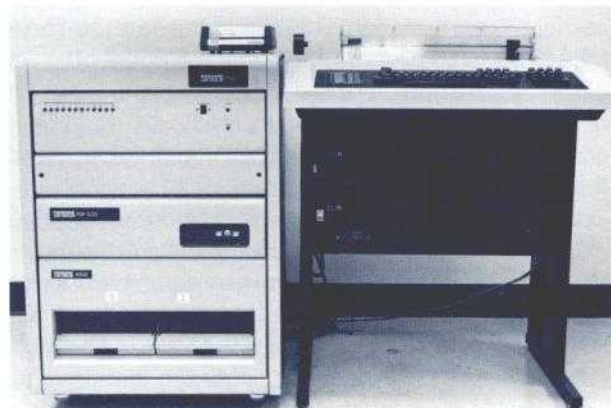

Figure 7. FM voice channel monitor system improves accuracy of future traffic predictions

installed at the Southbury INMARSAT coast earth station. This system monitors the traffic channels designated for voice to determine their in-band data loading. The data base created by this system will be used to improve the accuracy of predicting future traffic requirements.

The monitor system consists of a set of fixed threshold signal detectors whose output is sampled and stored in a computer file for analysis to determine whether the traffic is voice or data and to collect call duration statistics for the data signals. A variety of table and graphic outputs can be generated to help interpret the measurements.

A test scenario, loaded via a computer terminal, assigns each input channel to one of three pools and then specifies the test duration, sampling resolution, and data boundaries used in computing the call-duration histograms. Data storage is provided on a floppy disk and data within each pool may be analyzed separately or combined.

COMSAT SUPPORT

Space Communications Division

Shipboard TV Experiment for Maritime Services

COMSAT has undertaken the task of integrating and demonstrating a system to transmit television programs such as news and sports highlights to ships



at sea. Initial examination indicated that it was not feasible using the INMARSAT satellites to transmit unprocessed, full-motion video to ships via conventional means. However, further examination indicated that limited-motion video programs could be transmitted to ships at sea via the INMARSAT satellite by using compressed video (i.e., highly source-encoded video) and FEC coding on the digital carrier.

COMSAT proposed, and in 1986 will conduct, an experiment using this latter technique. COMSAT Laboratories undertook a preliminary experimental investigation of the system hardware and system performance. Figure 8 is a block diagram of the system which was simulated in the laboratory. The video signal, compressed with a video codec (furnished by Compression Labs, Inc.), produced a 768-kbit/s digital stream of multiplexed audio and video. This digital stream was modulated with quadrature phase-shift keying (QPSK) after being encoded by a rate 1/2 convolutional FEC coder. The output of this modulator was then combined with thermal noise to simulate actual channel conditions and then connected to the input of the QPSK demodulator, which used soft-decision detection and sequential decoding. The resulting digital stream was connected to the input of

the video decoder, which produced a composite NTSC video signal and companion audio signal for evaluation.

Laboratory results show that the achieved video performance is sufficient for shipboard use under all but the most severe operational conditions. Based upon these results, the system hardware will be installed and tested on board a transoceanic passenger ship in early 1986.

Communications Services Division

120-Mbit/s TDMA/DSI Subjective Tests for COMSAT International Communications, Inc.

COMSAT Laboratories and Martlesham Laboratories, U.K., conducted a two-way active talker subjective experiment during the preoperational testing of the 120-Mbit/s TDMA/DSI system. Full-period, unconditioned, leased circuits were used between the earth stations (Etam, West Virginia, and Madley, United Kingdom) and the Laboratories. The purpose of the experiment was to evaluate the performance of the DSI system under stressed, controlled loading conditions. Identical loading was provided in both

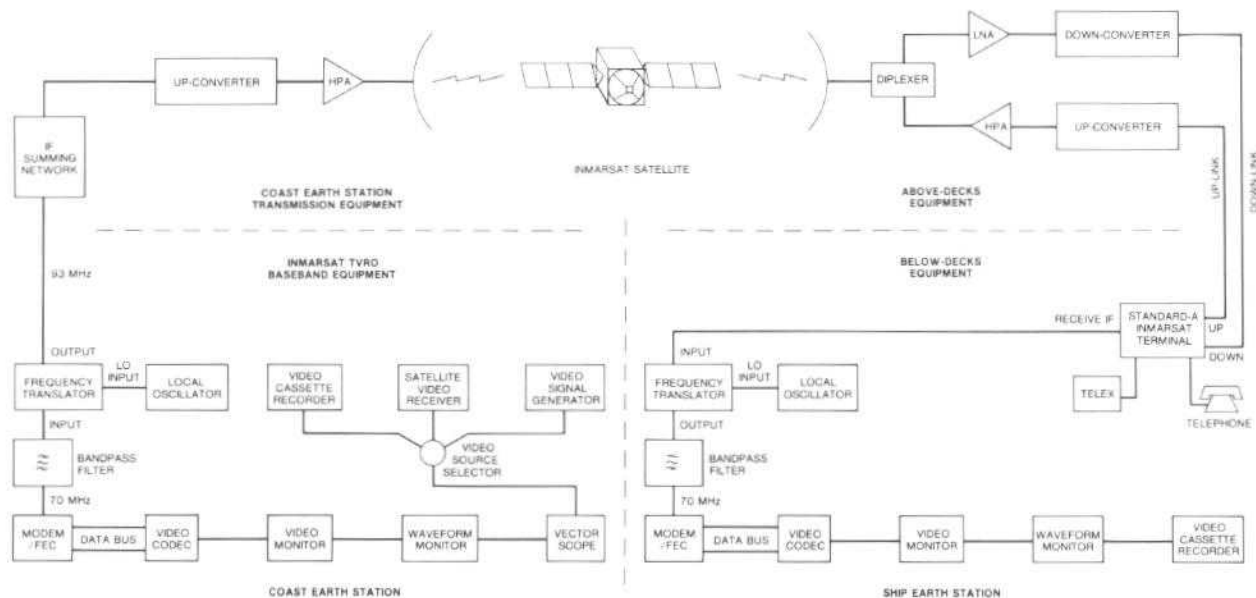

Figure 8. COMSAT/INMARSAT shipboard TVRO experiment has been simulated at COMSAT Laboratories

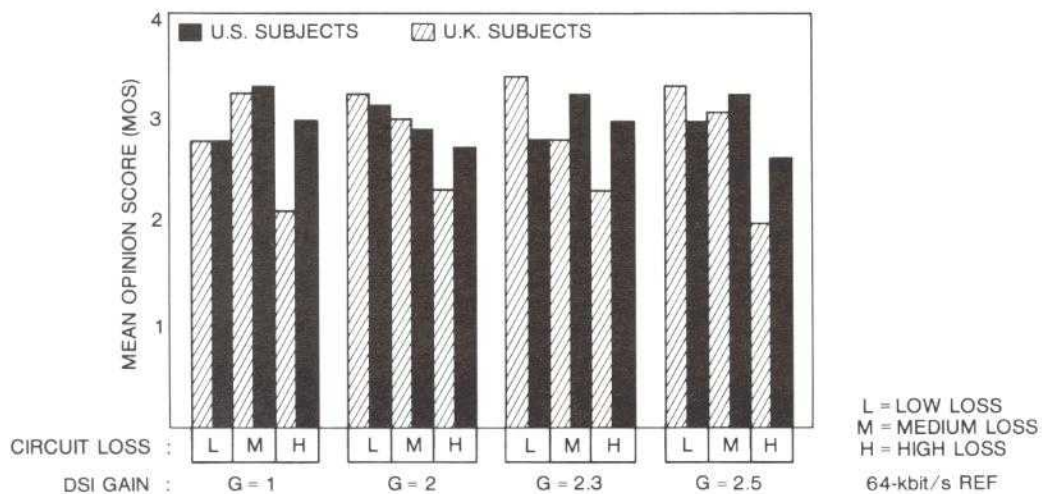

Figure 9. Subjective evaluation indicates that TDMA/DSI quality is affected by terrestrial extension conditions more than by DSI gain

transmission directions by a speech activity simulator located in the U.S. This simulator output, with 40-percent activity, was sent to the U.K. on a separate, noninterpolated TDMA/DSI sub-burst, where it was looped and used to load the DSI system on the U.K.-to-U.S. link.

A 12 x 12 Greco-Latin square experimental design was used where DSI gains of 2.0 (60/30), 2.3 (120/52), and 2.5 (120/48) were tested with terrestrial extensions having low, medium, and high loss. The reference circuits used were 64-kbit/s PCM digital noninterpolated channels (DNI) with the same low, medium, and high terrestrial extension loss conditions. Echo cancellers were used at the U.S. end and echo suppressors at the U.K. end.

The experimental results illustrated in Figure 9 show minor differences between DNI channels and the interpolated channels. The observed differences appeared to be associated with the terrestrial extension conditions rather than DSI gain. The tests show that the TDMA/DSI system performed well and that subjective quality is influenced primarily by factors such as terrestrial extension loss rather than DSI gain.

HI-NET System Simulation

In 1984 COMSAT entered into an agreement with the Holiday Corporation to establish the HI-NET network, a satellite transmission system to distribute video and audio program material to 1,500 Holiday

Inns in the United States. HI-NET will provide entertainment programming, video teleconferencing, and teleseminar services among the Holiday Inns.

As the design of the system evolved, extensive laboratory tests were conducted on behalf of COMSAT General to provide proof-of-concept and link design information, and to evaluate equipment for potential use in the system. Of particular significance was a series of tests which measured video and audio crosstalk, differential phase and gain, and noise transmission at the HPA and transponder outputs for two carriers in the HPA and transponder. These measurements were performed for amplitude and group delay equalization optimized at the HPA and transponder traveling wave tube amplifier (TWTA) inputs.

Table 1 gives test results. The data for cases A and B were observed at the HPA and transponder outputs, respectively, for the optimized gain and delay. Table 1 indicates no major degradations in any of the test parameters evaluated.

COMSAT Technology Products

LR-TDMA Modem and FEC Codec

COMSAT Laboratories is developing a modem and codec for use in a LR-TDMA system for COMSAT Technology Products, Inc. Intended to operate in the 2-to 20-Mbit/s range, the system has been designed



Table 1. System Performance Test Results

	Case			
	A		B	
Configuration				
System	HPA		HPA/Transponder	
Equalization ^a	HPA/Transponder		HPA/Transponder	
IF Bandwidth	18 MHz		18 MHz	
HPA _{P_{out}} (W)	1,000	500	1,000	500
Transponder Input Backoff (dB) ^b	N/A	N/A	-1.5	-1.5
C/N (dB)	32.0	31.8	29.8	29.9
Video Measurements ^c				
Subjective Crosstalk	NM	NM	Faint	Fainter
Measured Crosstalk Amplitude (IRE pk-pk)	NM	NM	1.6	NM
Chromo Phase ^d (deg pk-pk)	NM	NM	2.0	1.0
Diff Phase (deg)	1.1	1.4	1.2	0.8
Diff Gain (%)	0.5	0.5	1.0	0.75
S/N _w (dB) ^e				
Theory	62.3	62.1	60.1	60.2
Measured	61.8	61.7	57.8	57.7

^a Equalization added as needed so that amplitude and group delay as flat as possible at transponder TWTA input (HPA/transponder).

^b Total input backoff referenced to single carrier saturation.

^c NM indicates quantity unobservable or so small it is not measurable.

^d Includes 0.5° present in measurement setup, exclusive of HPA and transponder.

^e Peak-to-peak luminance to weighted rms noise.

with sufficient flexibility to handle most of the requirements that arise in the business service marketplace. Besides variable data rate, the system has frequency-synthesized channel selection and is capable of hopping between channels on a burst-to-burst basis.

By the close of 1985, the entire modem had been designed, the printed circuit board layout for the modulator completed, and the modulator debugged from baseband to its first intermediate frequency (IF) at 42.8 MHz.

Digital signal processing (DSP) techniques were used as extensively as possible in the design of the

modulator and demodulator to obtain a cost-effective, manufacturable design. The DSP approach allows great flexibility as it is a digital implementation scaled with the data rate. In addition, many of the operational parameters are programmable.

Figure 10 is a block diagram of the LR-TDMA modulator. The critical spectral shaping of the transmit signal is performed digitally at baseband and channel selection synthesis is facilitated by a double frequency conversion IF. The demodulator is shown in Figure 11. Like the modulator, it also has a double conversion IF and processes the in-phase and

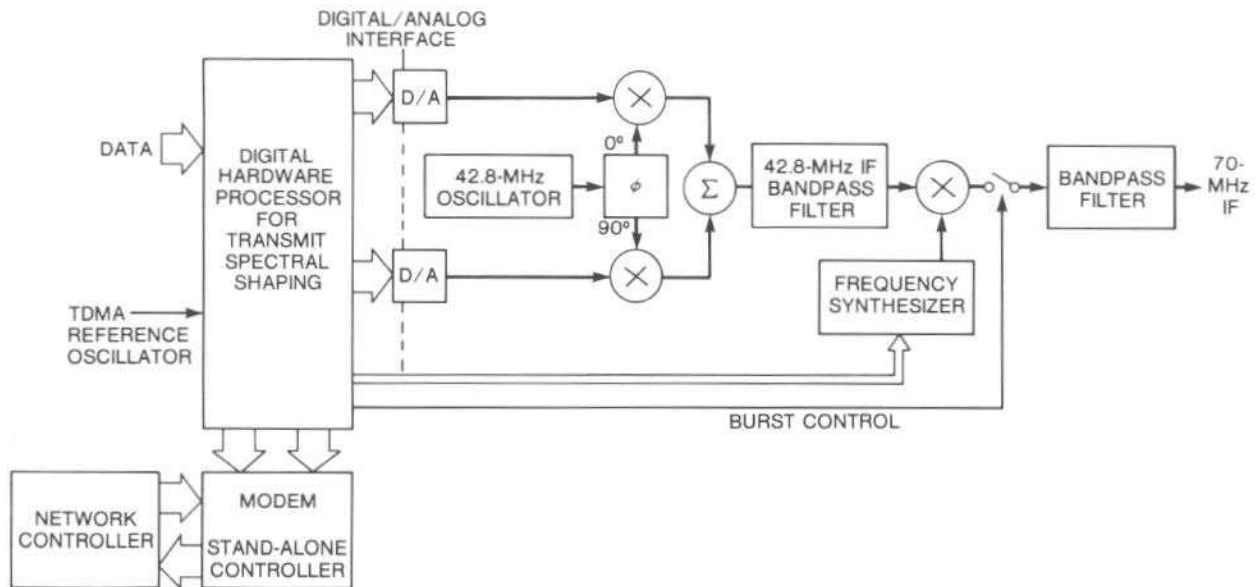

Figure 10. LR-TDMA modulator

quadrature I and Q channels digitally at baseband for automatic gain control and coherent carrier and clock recovery.

An FEC coder/decoder (FEC codec) for the (128, 112) Bose-Chaudhuri-Hocquenghem (BCH) code is being developed for the COMSAT Technology Products, Inc., LR-TDMA system. The low-bit-rate BCH codec employs a modified version of a unique 8-bit parallel architecture. The codec corrects all 1- and 2-bit error combinations within a code block and detects all 3-bit errors. The resulting 2.6 dB of coding gain at a BER of 10^{-6} is accomplished with only 12.5-percent redundancy in the transmitted data.

In addition to the novel parallel feedback shift register implementations of the encoder and syndrome generator, several other innovations are used in the decoder. A special pipelined structure processes both ordinary code blocks and the short blocks which occur at the ends of TDMA bursts, while minimizing the hardware. A ping-pong random-access memory requires only about one-fourth the circuitry of previous shift-register input buffers, and only four erasable programmable read-only memory chips are needed to store the 2^{14} error location numbers, cor-

responding to the syndrome patterns for all single and double bit errors.

INTELSAT

SUPPORT

Companded Single-Sideband Co-Channel Interference Investigation

CSSB amplitude modulation (AM) is being introduced into satellite communications as a means for transmitting a large number of voice channels in a given transponder bandwidth. Four types of co-channel interfering carriers (QPSK, FDM/FM, FM with energy dispersal frequency waveform only, and CSSB) were used to interfere with a CSSB test carrier transmitting speech or voiceband data. Measurements of S/N were made at the test channel output. BER measurements were made using a 4,800-bit/s modem.

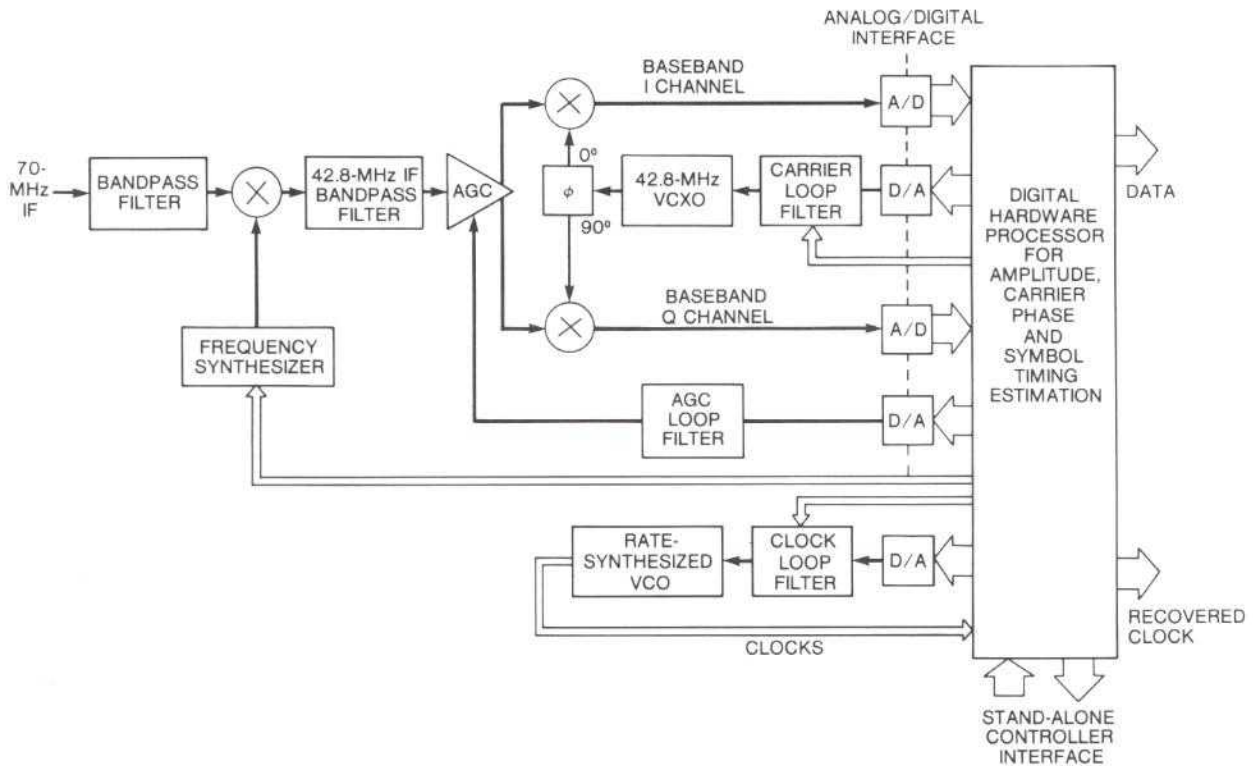

Figure 11. LR-TDMA demodulator

The S/N results indicate good agreement between measured and predicted performance, showing that wideband interferers affect the CSSB carrier in the same manner as thermal noise. Since narrowband interferers (i.e., CSSB voice and signaling) were more "intelligible," they were objectionable at interference levels lower than equivalent amounts of thermal noise.

The BER results on CSSB voiceband data transmission similarly indicated that the interferers resembling random noise (QPSK, FDM/FM, and CSSB voiceband data) had the same effect as an equivalent amount of thermal noise, while tonal type interferers (energy dispersal frequency and CSSB signaling tones) caused varying, and at times severe, BER degradations, depending upon the exact interferer spectrum and level.

A limited subjective evaluation indicated that the relative severity of the degradation was consistent

with the S/N for the same interferer type. Interferers which resembled incoherent noise tended to blend with the background thermal noise, while those which resembled tones or speech tended to be much more noticeable. Frequency offsets and spectral inversions reduced or eliminated the intelligibility of interfering CSSB speech, although they also affected the relative noticeability of the CSSB interferer by altering the audio frequency at which the interferer appeared within the test channel.

These tests indicate that CSSB can be used for voice and data services over satellite systems in which the level of narrow-band interference is low. In satellite systems with a high degree of frequency reuse, special care may be required to achieve acceptable performance.



OTHER

NASA

MSAT-X Land Mobile System Ground Terminal Design

Various commercial land mobile satellite systems have been proposed in the U.S. and abroad to supplement the terrestrial cellular radio systems for providing services to rural and remote areas. Potential mobile satellite services include telephony, voice and alphanumeric message dispatch, paging, data broadcasting, position polling of vehicles, electronic mail, and distress and emergency messages. To accelerate the introduction of commercial mobile satellite services in the U.S. and ensure future growth, NASA has formulated the Mobile Satellite Experiment (MSAT-X) program in cooperation with the industry to develop high-risk technologies. Emphasis is on the development of space segment and ground segment technologies to efficiently utilize the limited spectrum and orbit resources allocated for land mobile satellite use.

COMSAT Laboratories, under Contract 957113 from NASA/Jet Propulsion Laboratory, is conducting a detailed system design and performance specification study effort for the UHF mobile transceiver, the SHF base station, and the SHF gateway station which interfaces with the public switched telephone network.

Major technical issues addressed by COMSAT include the following:

- frequency stability control
- modulation techniques
- error control methods
- 2,400-bit/s linear predictive coding (LPC) vocoder algorithms
- transceiver architecture and interface design.

Figure 12 shows a flexible, modular transceiver architecture designed and specified for the MSAT-X system. The transceiver consists of a microprocessor control unit, antenna, RF/IF units, modem, vocoder, FEC codec, and input/output peripheral modules. The choice of a binary FM modulation technique allows for low-cost, 2,400-bit/s information rate transmission over the land mobile satellite channel in the presence of multipath fading. Convolutional coding with Viterbi algorithm decoding minimizes the antenna size and channel degradations. The LPC vocoder is specifically

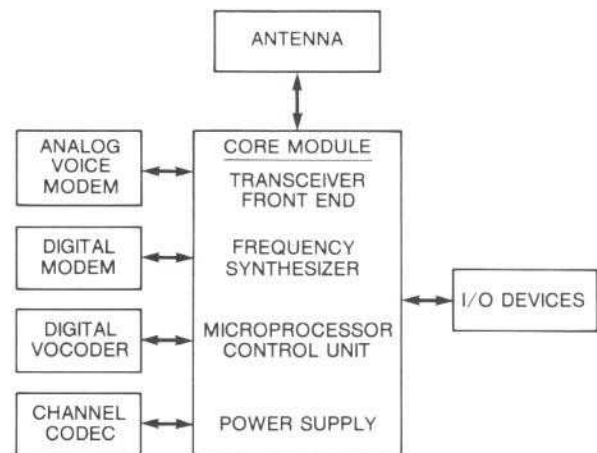

Figure 12. Mobile transceiver features flexible, modular design

designed to minimize performance degradation due to acoustically coupled background noise, channel distortion, and multipath fades.

INMARSAT

Standard-B Communications Subsystem Test Bed

INMARSAT is currently planning an all-digital transmission system to augment its current one in the 1990s. Designated as Standard-B, the system supports 16-kbit/s adaptive predictive coding (APC) voice, as well as 300- and 600-bit/s and 1.2-, 2.4-, 4.8-, 9.6-, and 16-kbit/s circuit and packet-switched data services. With efficient filtered QPSK or offset QPSK (O-QPSK) modulation, and powerful convolutional coding and soft-decision Viterbi decoding, the single-channel-per-carrier voice and data channels are modulated on 24-kbit/s carriers which will be spaced only 20 kHz apart as compared to the 50-kHz spacing in the current system. Each of these 24-kbit/s channels requires substantially lower power than the current system. With a single type of modulation at the same data rate, a single modem can transmit and receive access control and signaling messages as well as voice and data traffic, thus lowering the below-the-deck equipment cost of the ship earth stations (SESS).

To help determine the transmission schemes and to optimize the system parameters for the Standard-B

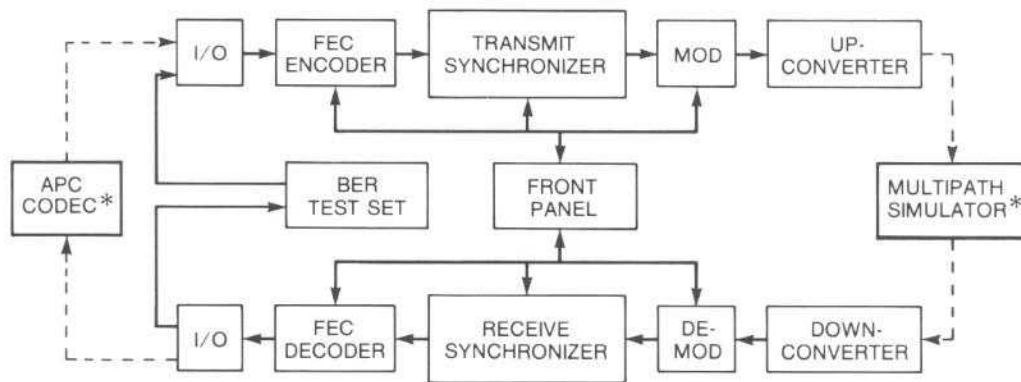

* NOT INCLUDED IN TEST BED

Figure 13. Standard-B test bed unit being developed at COMSAT Laboratories

system, COMSAT Laboratories has been studying the transmission techniques for voice, data, and signaling of the Standard-B system and is developing a test bed for INMARSAT under contract INM 84-101 to finalize the system design and parameters with measurements and tests. The Standard-B test bed (shown in Figure 13) consists of a coast earth station test bed unit and an SES test bed unit, each including a DSP-based modem, a Viterbi algorithm FEC codec, transmit and receive synchronizers, and an up- and down-converter channel selector. The DSP-based modem can be operated in binary phase-shift keying

(BPSK) mode at 12 kbit/s, QPSK mode at 24 kbit/s, and O-QPSK mode at 24 kbit/s. The Viterbi decoder is capable of decoding rate 1/2, constraint-length 7 or 9, convolutional codes, or rate 3/4 punctured convolutional codes derived from the rate 1/2 codes. The up- and down-converter channel selector converts between the very low IF suitable for DSP processing and the standard IF of 21.4 MHz. The test bed units are designed to interface to a multipath simulator and APC voice codec which INMARSAT is procuring from different sources.

MICROWAVE TECHNOLOGY DIVISION

INTRODUCTION

The Microwave Technology Division (MTD) of COMSAT Laboratories performs research, development, and support functions in a wide range of technical areas encompassing all aspects of communications systems. These areas include the development of monolithic microwave integrated circuits (MMICs) for both satellite and earth station applications, MIC and waveguide filters, on-board repeater processing techniques, satellite monitoring and in-orbit testing, new earth station and satellite antennas, propagation evaluation, and fiber and free space optical communications.

In the R&D area significant progress has been made in MMICs and miniaturized microwave active circuits (MMACs), antennas, feeds and components, microwave multicoupled cavity filters, propagation modeling, optical intersatellite link analysis, and hardware development. In the support function, the MTD has participated in antenna measurements at Southbury, an aeronautical data link experiment, and studies for INMARSAT. Finally, design efforts and consultancy have been successfully performed for companies such as RCA, GTE, and Selenia Spazio.

COMSAT R&D

Jurisdictional — INTELSAT Related

Optical Transceiver Subsystems for Intersatellite Links

As in previous years, advanced communications research has continued in both hardware development and experimental demonstration of communications performance relevant to optical intersatellite links (ISLs). A bipolar temperature controller and digital thermometer circuits were developed and tested for active control of the core temperature of a diode laser. Test facilities established in-house were used to characterize a high-power single transverse mode diode laser [Hitachi HLP-1400, 30-mW continuous wave (CW) output] and a 10-diode laser array (Spectra Diode Laboratories SDL-2410, 100-mW CW out-

put) for output power, modal (spatial), wavelength, and thermal stability. A second compact laser transmitter module was developed to test the feasibility of the laser power combining schemes. Using two orthogonally polarized lasers and beam-shaping optics, an overall power combining efficiency of ~84 percent was measured at the output of the combiner. This efficiency could be further improved by using anti-reflection coated optics.

A high-speed, high-current digital laser driver module capable of driving two 50- Ω complementary loads with currents up to 100 mA and data rates of 420 Mbit/s was developed and tested (Figure 1). A clock recovery circuit to relock the received data with the clock recovered from the data at 420 Mbit/s was also developed and transmission tests performed. Because of slow, homogeneous degradation in diode lasers, the output power at a fixed drive current as well as the slope of the output power vs drive current curve are reduced with aging. Thus, for long-life operation of the link, both the average and the peak output power must be maintained at their preset values. Laser drivers with active opto-electronic feedback control circuits to compensate for such aging effects were designed, constructed, and tested.

A low-noise broadband preamplifier was developed for the 4-GHz microwave high-speed analog transmission optical link, and the link was characterized with respect to amplitude and phase noise performance. The noise level of this link was measured to be 3 dB greater than that of the link containing the

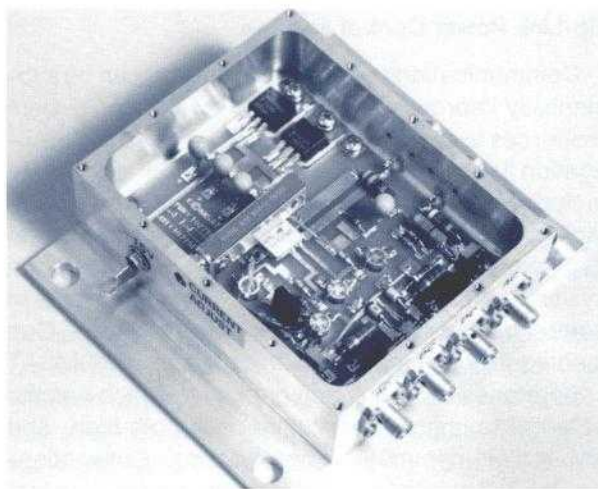

Figure 1. High-speed, high-current digital laser driver operates at 420 Mbit/s

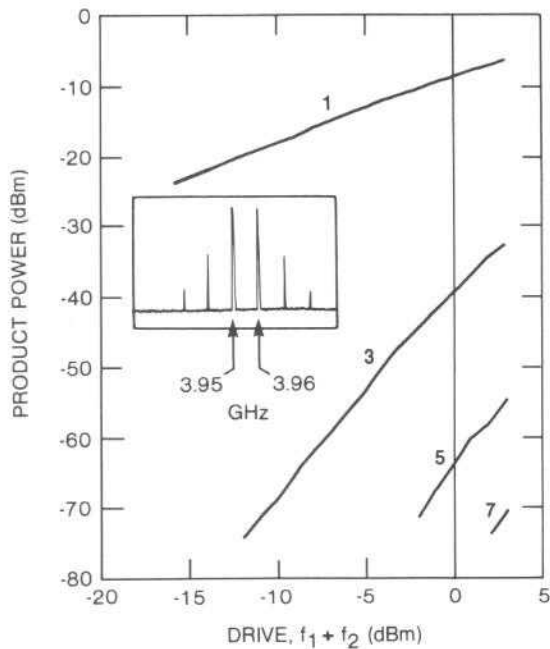

Figure 2. Two-tone intermodulation characteristics of diode lasers at ~4 GHz

Hitachi HLP-1400 diode laser. Measurements of the frequency response and two-tone intermodulation characteristics are shown in Figure 2. This link was also used at 4 GHz to test the suitability of wideband FM subcarriers vis-à-vis direct baseband analog transmission.

Up-Link Power Control Analysis

Communications system performance can be substantially improved by adaptively distributing system resources to restore performance on impaired propagation paths. Examples of mitigation techniques include transmit (up-link) power control to overcome fading, adaptive depolarization compensation to maintain polarization isolation in dual-polarization systems, and adaptive forward error correction to control bit error rates (BERs) in digital systems. One technique now under active investigation at COMSAT Laboratories is up-link power control, which has the potential to improve performance in both high- and low-margin communications systems. Conventionally, up-link power control is implemented by monitoring the down-link attenuation, and then scaling attenuation to the corresponding up-link frequency.

Measured data on the correlation of path fading at different frequencies were compiled and analyzed to estimate the attainable performance of up-link power control networks. Because down-link beacons are not permitted in the up-link (14-GHz) region of the K_U -band, concurrent 14- and 11-GHz attenuation data were collected in the loopback mode; these data are particularly sensitive to measurement errors. The most useful data were concurrent 30- and 20-GHz fade statistics, obtained, for example, from dual down-link beacons on the COMSTAR satellites. The analysis was performed by investigating the instantaneous attenuation ratio vs down-link attenuation, as illustrated with specified measurement error bounds in Figure 3.

For the 30- and 20-GHz bands, the study indicated that atmospheric rainfall variations will impose uncertainties of about 2 dB in 30-GHz attenuation scaled from 20-GHz measured fades. To achieve these accuracies, it will probably be necessary to employ an algorithm that approximately subtracts out gaseous (non-rain) path losses (i.e., by baseline removal), and to filter out most short-term (≤ 1 -s) fluctuations in down-link fade level.

MMIC Design Technology

The long-range goal of this task is the development of monolithic satellite receivers consisting of low-noise amplifiers (LNAs), fixed and variable gain blocks, mixers, and oscillators. It is conducted in close cooperation with the Microelectronics Division, which fabricates all MMAC and MMIC circuitry. These modules

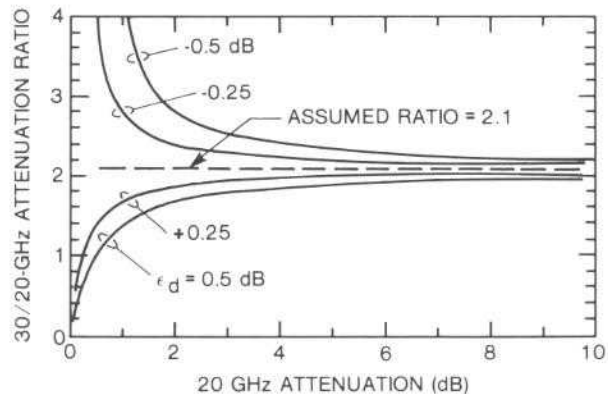

Figure 3. Effect of variation (E_d) in down-link measurement accuracy on corresponding attenuation ratio at 30/20 GHz

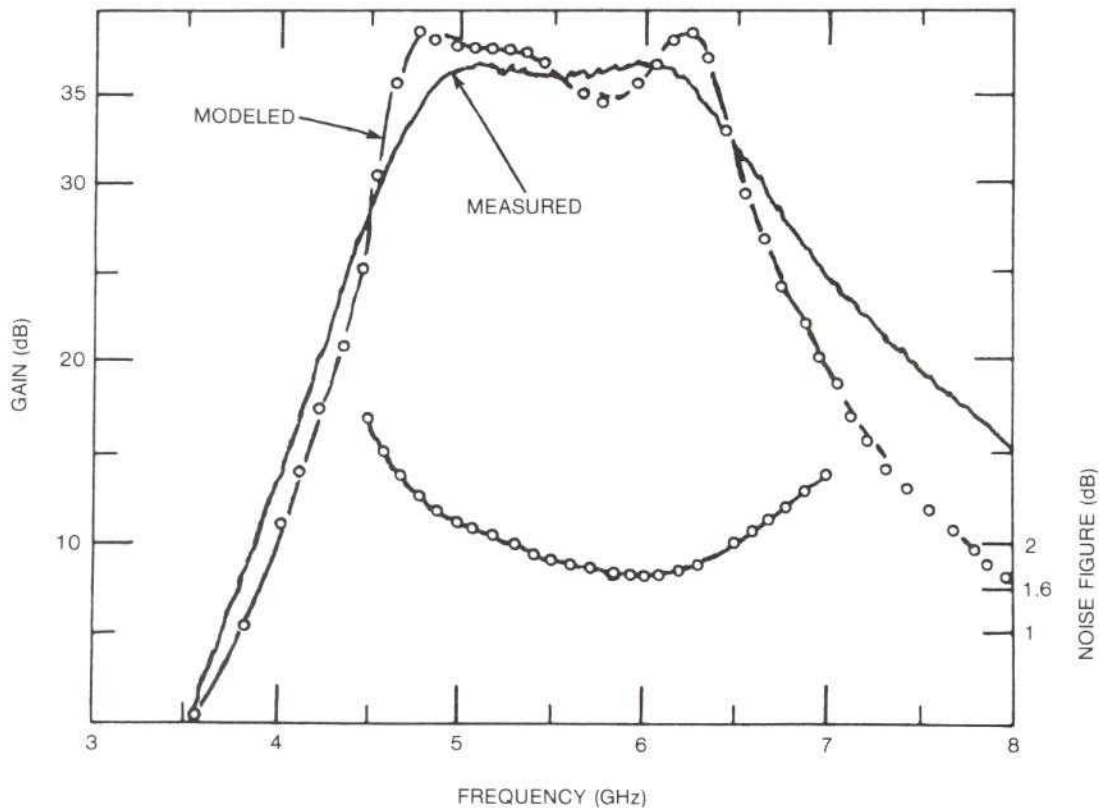
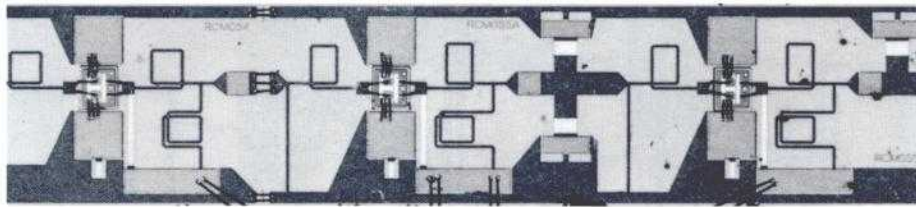

Figure 4. Measured performance of 6-GHz, three-stage quasimonolithic amplifier exhibits close correlation with computed response

were realized in MMAC form during 1984 and 1985; future emphasis will be on a fully monolithic realization.

In the first half of 1985, a 3-stage 6-GHz MMAC LNA having a gain greater than 35 dB and a noise figure of 1.6 dB was designed and fabricated on a gallium arsenide (GaAs) substrate. The close correlation between computer-modeled and measured responses is shown in Figure 4. This background work has led to the development of 6-GHz MMIC amplifiers such as a two-stage, 2- × 3.5-mm, 6-GHz

MMIC LNA with predicted gain of 20 dB and a noise figure of 1.8 dB.

In addition, a two-stage 4-GHz MMAC amplifier was realized during 1985. Measured results from this amplifier have led to the design of a two-stage monolithic amplifier using feedback techniques. The predicted gain and noise figure are 12 dB and 3.5 dB, respectively.

Development of a highly reliable, compact, lightweight microwave switch matrix using MMIC tech-

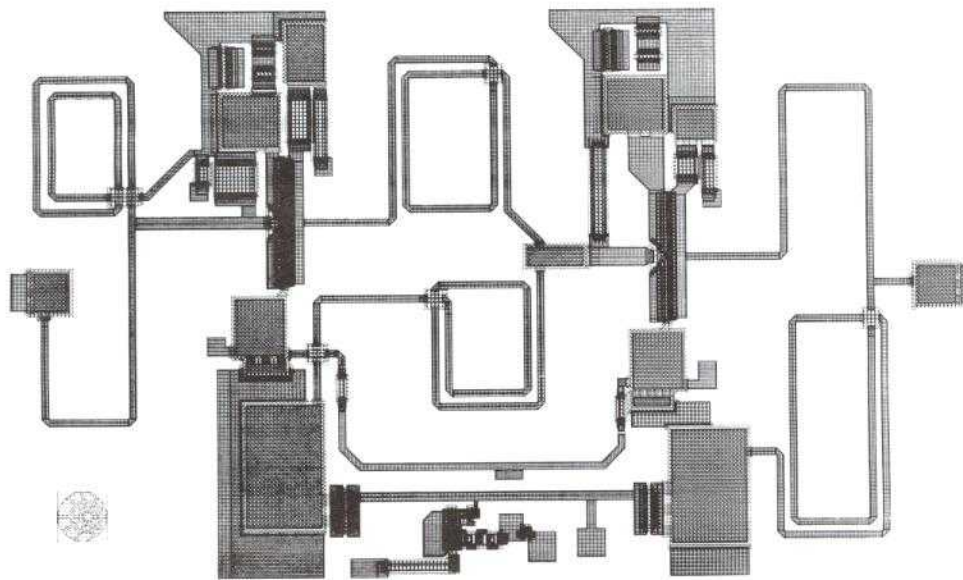

Figure 5. Fully monolithic dual-gate FET switch operates over 3.5 to 6.5 GHz

nology continued during 1985. Figure 5 shows a layout of a fully monolithic dual-gate field effect transistor (FET) switch circuit for operation over 3.5 to 6.5 GHz. The chip, which is compatible with transistor-transistor logic (TTL) control, is self-biased with a single positive power supply. The control logic has been integrated in the RF circuit and the chip size is 1.5×2.5 mm.

A novel monolithic matched switch circuit consisting of single-gate active and passive FETs has also been implemented. This circuit, shown in Figure 6, is matched over 3.5- to 6.5-GHz bandwidth in both ON and OFF states of the RF switch.

The above module designs are based on the lumped element models for the FETs (single-gate active, single-gate passive, and dual-gate FETs) developed in-house. These models have been derived from device physics and geometry and have been validated by measurements on FETs fabricated in-house.

Antenna and Feed Components

The potential for increasing the frequency bandwidth of the 4/6-GHz circular diplexer was investigated. This diplexer was originally developed for the INTELSAT V frequency bands, and design modifications are necessary to accommodate the broader INTELSAT VI bands. The conclusion of the study was

that there would be no performance problems in the expanded 6-GHz transmit band, but that performance in the expanded receive band would degrade rapidly below 3.62 GHz. Additional investigation indicates that modification of the circularly polarized diplexer for use in the "Second Generation" INMARSAT bands (3.60 to 3.62 GHz and 6.425 to 6.441 GHz) also appears promising. Other diplexer developments consisted of a high-quality transmit reject filter that can be fabricated by a lower cost casting technique and an investigation of the use of thicker irises in the corrugated coupling region to reduce fabrication costs.

K_U -band diplexers were studied as an essential component of 11/14-GHz dual-polarized feeds. A "Y" junction diplexer separating 11- and 14-GHz signals from a common WR75 waveguide into separate WR75 waveguides was completed. This project included evaluation of various filter geometries that not only provide good electrical performance but also are amenable to low-cost fabrication techniques.

Microwave Filter Technology

Mode frequency degeneracy in cylindrical cavities was investigated by writing a computer program which would permit dual, triple, and quadruple mode degeneracies to be identified as a function of frequency spacings between the upper and lower

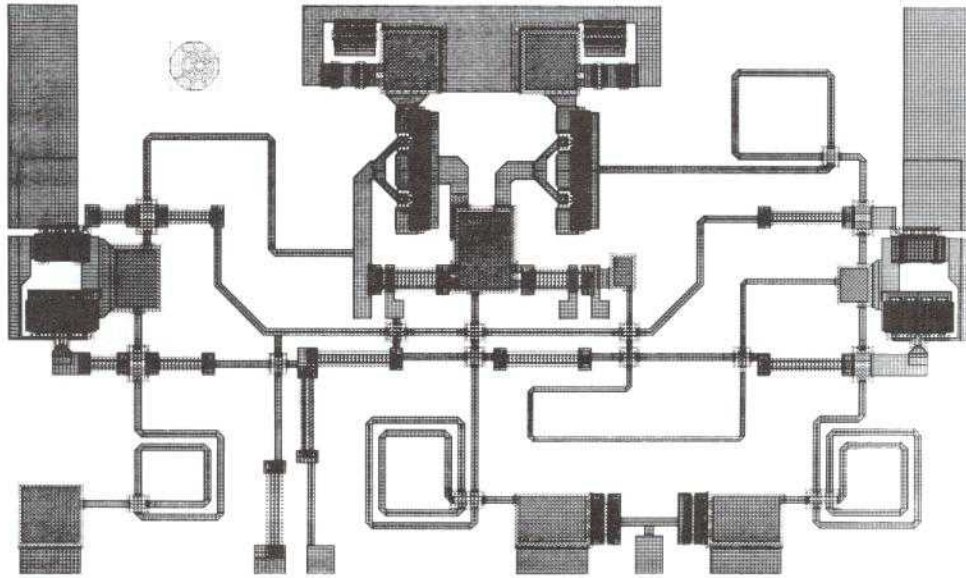

Figure 6. Novel monolithic matched switch circuit consists of single-gate active and passive FETs

spurious modes. Weight and volume estimates along with cavity Q's of the degenerate modes were computed. The application of this program resulted in the following fundamental conclusions:

- The dual TE_{11n} mode is practical only for $n = 1$ to 4. For $n > 4$, the frequency width of the windows is too small to justify the small Q improvement (see Figure 7).
- A number of triple mode degeneracies that allow practical filters to be realized have been identified. Triple mode degeneracies occur for the dual mode TE_{11n} and TM_{1mn} modes, and the fundamental triple mode degeneracy occurs for the dual TE_{111} and TM_{010} modes.
- Dual modes can also be realized in the TM_{1mn} modes. Filters of this type have been realized although they do not seem to offer any significant advantages over the dual TE_{1mn} modes.
- Quadruple mode degeneracy occurs when the dual TE_{11n} and dual TM_{1mn} modes resonate at the same frequency. A number of useful operating modes have been identified, for example, the TE_{112} and the TM_{110} modes. A four-pole elliptic filter function has been realized at 4 GHz using these modes and a Q of 15,000 was achieved. The filter is shown in Figure 8 along with its transmission and return loss.

Solid-State Power Amplifier Development

As part of an ongoing effort aimed at the realization of low-cost, highly reliable, miniaturized solid-state power amplifiers (SSPAs) for application in future satellites, the MTD is developing a family of MMIC amplifiers at 4, 11, and 20 GHz. Each amplifier design is intended to emphasize a unique potential or address a problem area unique to MMIC amplifiers in that frequency range.

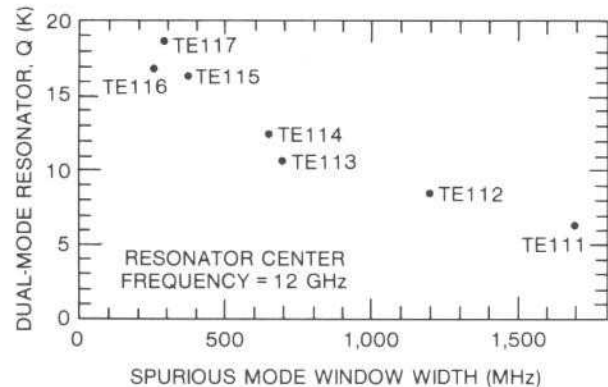

Figure 7. Spurious mode window vs Q for various dual TE_{11n} modes

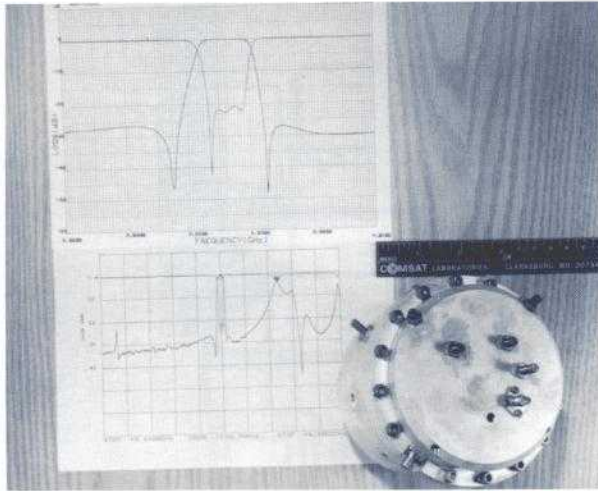

Figure 8. Quadripole elliptic function filter realized at 4 GHz achieves a Q of 15,000

At 4 GHz, where FET gain is relatively high, the emphasis is on increasing efficiency and linearity. To this end, amplifiers operating in class B or AB are being developed. Class B operation is theoretically capable of increasing amplifier efficiency by about 50 percent over that which is achievable with class A. To fully exploit this operating mode, both single-ended

and push-pull circuits are being developed. The advantage of the push-pull version is that it is significantly more linear, especially at low input levels, than the single-ended circuit. The main disadvantage is that it requires the use of a *balun* to convert the usually encountered "unbalanced" transmission mode into a "balanced" mode. This disadvantage can be converted into a partial advantage if the amplifier is connected directly to a radiating element, which is usually "balanced." A lumped element balun has been developed which will allow a significant reduction in the size of push-pull amplifiers. Circuits have also been designed for a 0.5-W single-ended amplifier and for a 1.0-W push-pull amplifier, both for the 3.7- to 4.2-GHz frequency band.

At 11 GHz, the emphasis is on developing accurate FET and passive component models. Work in this area has focused on the measurement of COMSAT-developed FETs under well-defined and controllable circuit conditions.

At 20 GHz, the goal is to develop low-loss impedance matching techniques which will not degrade significantly the maximum available gain of the FET devices being used. Both single- and two-stage designs have been completed and masks designed (see Figure 9). The single-stage version should deliver 0.5 W with about 4-dB gain, while the two-

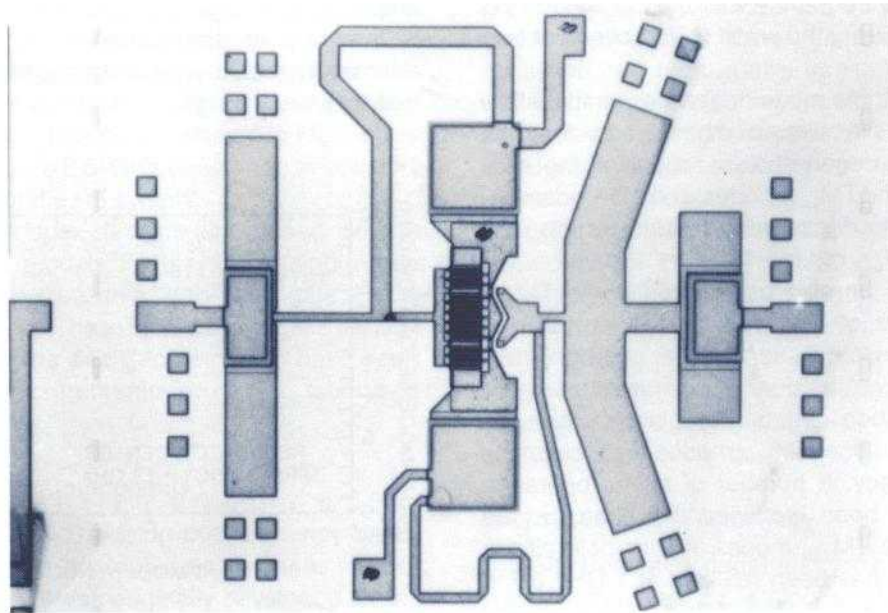

Figure 9. Single- and dual-stage 20-GHz MMIC amplifiers deliver 0.5 W at 4- and 8-dB gain, respectively

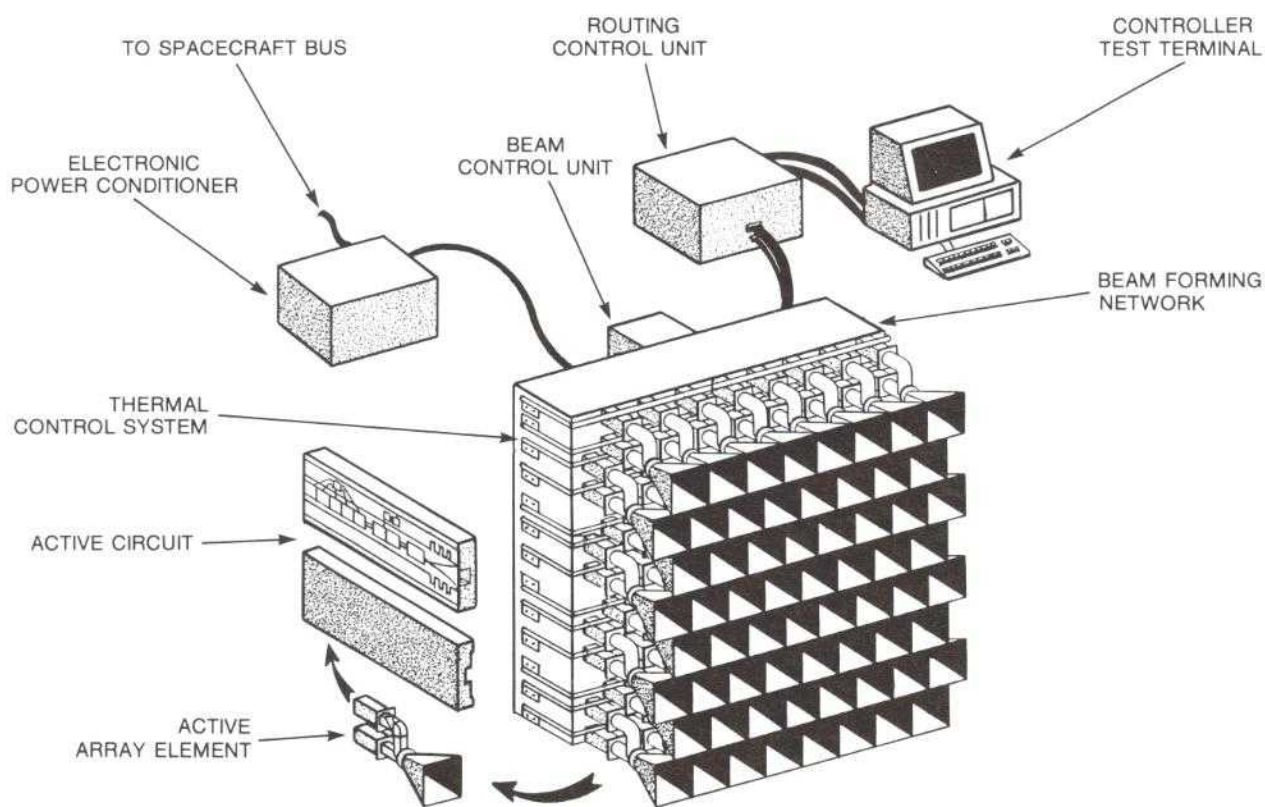

Figure 10. Active phased array contains 64 radiating elements

stage version will deliver the same power with about 8-dB gain.

Multibeam Phased-Array Antennas

Multiple rapidly scanned or hopping beams can be used to enhance the capacity of future satellite systems. This concept is being investigated by fabricating a high-power active phased-array antenna that can operate in a direct radiating mode or as a feed for a dual reflector system. Figure 10 is a conceptual drawing of the active phased array. This multidisciplinary effort involves building two arrays. The first is a 64-element dual-polarized low-power array fed by variable phase shifters and variable attenuators. The second is an array of 32 radiating elements, 16 of which will be fed by high-power amplifiers as well as variable phase shifters and variable attenuators fabricated with MMIC technology. The active circuits are controlled using a high-speed digital controller. Thermal and mechanical considerations constitute an essential part of the overall design. Fabri-

cation of various elements in the array began in 1985, with assembly and testing to be completed in 1987.

Dual Reflector Optics Study

This study consisted of three phases: a configuration study, an aperture synthesis study, and a study of shaped confocal reflector systems. The configuration study was to determine the advantages and disadvantages of a confocal Cassegrain system and a confocal Gregorian system for 9° scanning. A two-dimensional ray-tracing program was written to compare the performance of these two systems in terms of feed and subreflector blockage, spillover energy loss, and physical dimensions. Since the Gregorian system was found to have less blockage and less spillover while scanning up to 9° with comparable reflector sizes, it was chosen as the antenna configuration for the aperture synthesis study.

To synthesize the aperture field on the feed plane, the General Antenna Program (GAP) has been modified so that the near field of a reflector antenna can be



calculated on a specified planar surface. By using a receiving mode analysis in which a plane wave is incident on the main reflector with a given angle from boresight, the resulting near field on the feed aperture synthesizes the feed coefficients of the feed array. This array would produce a scanned beam in the opposite direction of the incident plane wave with minimum degradation, since the phase aberrations created by the reflectors have been compensated by the synthesized coefficients. However, because of the difference in the incoming and outgoing wave fronts on the feed plane, the synthesized coefficients compensate only part of the aberration errors. Still, an improvement of more than 0.5 dB has been observed in some scanned beams.

Finally, a surface-shaping technique based on the concept of bicollimated reflector designs has been investigated. With this technique, both the main reflector and the subreflector of a confocal antenna system are shaped so that the scan losses of the specified scanned beams are improved at the expense of the boresight gain. Preliminary results show that this technique indeed improves scan performance. Additional software to simulate the shaped surfaces in GAP is being developed for more accurate analyses.

Advanced Antenna Software Development

Two new computational techniques have been implemented to enhance the capability of the existing antenna analysis software package, GAP. Both of these methods allow pattern computations in a fraction of the time required by conventional direct integration techniques.

The first method improves the efficiency of antenna far-field computations by employing a sampling and reconstruction technique based on Shannon's sampling theorem. The far field is first computed along a small number of directions dictated by the theorem and then reconstructed at a number of user-specified points. The accuracy of the technique is excellent (0.03 dB). The central processing unit (CPU) usage of this technique is a factor of 15 times smaller than that of analogous computations performed by direct current integrations.

The second method involves performing a discrete Fourier transform (DFT) of the aperture distribution of a reflector antenna to obtain the far field. Software has been developed to perform this DFT efficiently through the use of fast Fourier transform algorithms. The

computational advantage of this technique over other direct methods is a factor of 10 to 15.

In addition, software utilities have been added for device-independent graphics, optimization of coefficients for beam shaping, aperture field plots, and feed definition by specifying measured data.

On-Board Demodulation/Remodulation

Development of a 120-Mbit/s, coherent quadrature phase-shift keying (CQPSK), 3.95-GHz regenerative repeater for on-board satellite applications continued during 1985. The repeater receives the digitally modulated microwave signal, and without intermediate frequency conversions, demodulates the baseband information. The circuit contains carrier and symbol timing recovery loops and pulse shaping filters.

A breadboard model was successfully tested for probability of bit error, cycle slipping, and probability of burst acquisition. The BER and receiver filter transfer characteristic are shown in Figures 11 and 12. Integration of the various parts of the breadboard

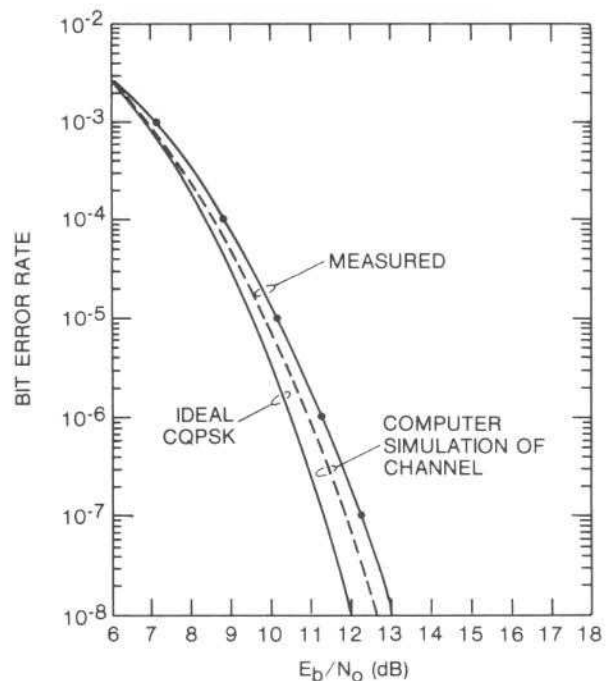

Figure 11. BER vs E_b/N_0 performance of the transmission channel is measured by the reverse modulation-loop demodulator

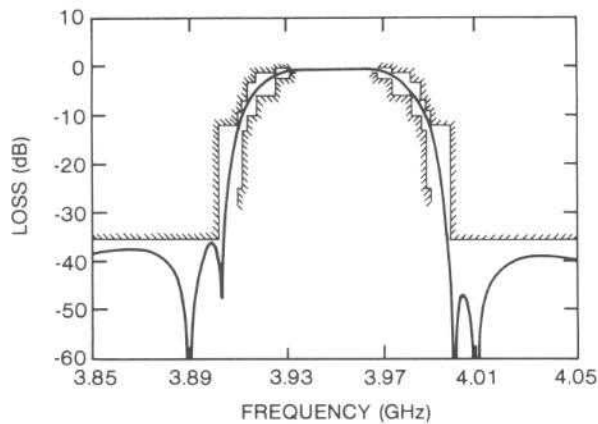

Figure 12. Response of dual-mode dielectric resonator receive filter

model into a single lightweight engineering unit is continuing.

Earth Station Antenna Technology

The Automated Antenna Measurement System (AMES) was further enhanced during 1985. The K_U -band measurement system was upgraded with an yttrium iron garnet (YIG) filter to produce a simpler receiver system, thus eliminating a cumbersome mixer system. L-band measurement software was written and used to test the Southbury INMARSAT station. An extensive set of flow charts and data subroutine descriptions were compiled in an operator's manual. To measure the performance of small aperture antennas, procedures were developed and are being implemented for the AMES to measure gain and G/T using the moon. Moon ephemeris programs have been written and are presently being installed in the AMES software. A verification program using the moon as a flux source to measure gain of C- and K_U -band antennas has also been completed.

Computer-Assisted Filter Tuning

This project consists of a system of computer-controlled test (microwave) equipment interacting with specialized computational subroutines to provide both characterization of a microwave circuit in its present state, and directions for tuning the circuit to another arbitrary state.

A prototype system has been developed to guide the tuning process, as well as to provide an estimate of the best response that could be achieved, given the con-

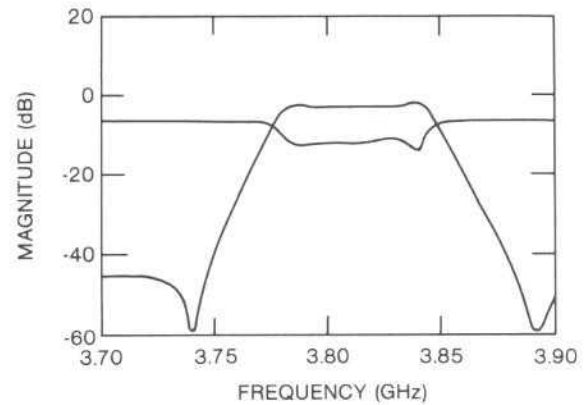

(a) Response before error function has been minimized

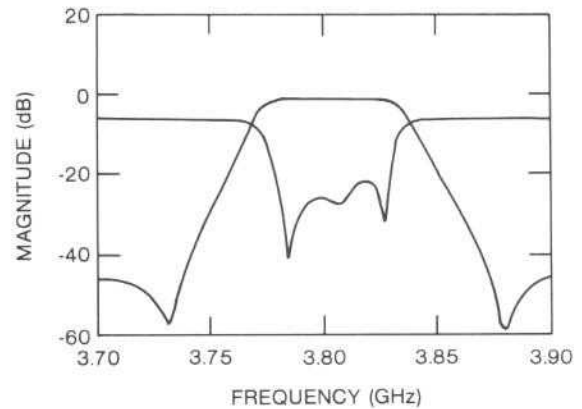

(b) Response after error function has been minimized

Figure 13. Computer-assisted equipment tunes filters faster and more economically

straints and/or limitations of the circuit being tuned. This will assist both in tuning filters (circuits) faster and more economically and in achieving realizations of complex structures and functions that were previously impractical.

The prototype system is presently capable of assisting in tuning a microwave filter from an untuned to a fully tuned state, given the data describing the fully tuned state. The operator adjusts the tuning screws of the filter to minimize an error function which is displayed vs frequency or as a single numeric value on the screen. Figure 13 shows the response before and



after the error function has been minimized. The system is relatively easy to use with repeatable results. A patent application for this method has been filed.

Non-Jurisdictional

Circuit Development for Amplica

A novel 3-dB hybrid coupler with 50 to 20- Ω impedance transformation was developed for balanced amplifier applications over the 3- to 5-GHz band. The coupler, shown in Figure 14, was built on 10-mil-thick alumina substrate with dimensions of 0.39 x 0.16 in. and results in a significant reduction in the size of balanced amplifiers.

Low-loss and compact interdigitated hybrids for 4 to 8 GHz and 8 to 12 GHz were developed in a coplanar waveguide (CPW) configuration for application to CPW balanced amplifiers. The insertion loss and amplitude flatness of the 4- to 8-GHz CPW coupler are 0.1 dB and ± 0.25 dB, respectively; those for the 8- to 12-GHz couplers are 0.35 and ± 0.3 dB.

A feedback broadband amplifier using quasimonolithic technology has been developed. This amplifier and its measured and predicted performance are shown in Figure 15. The gain across the 2- to 6-GHz bandwidth is 15 dB \pm 0.4 dB and its input and output return losses are better than 12 dB. The 2- x 3.5-mm module uses two self-biased stages and operates on a single +3-VDC bias.

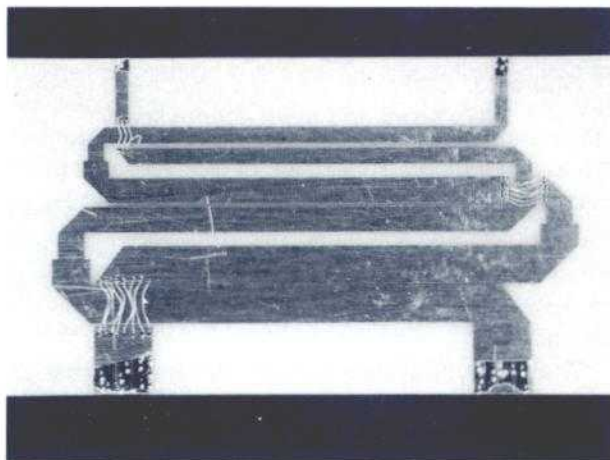

Figure 14. Novel 3-dB hybrid coupler results in a significant reduction in the size of balanced amplifiers

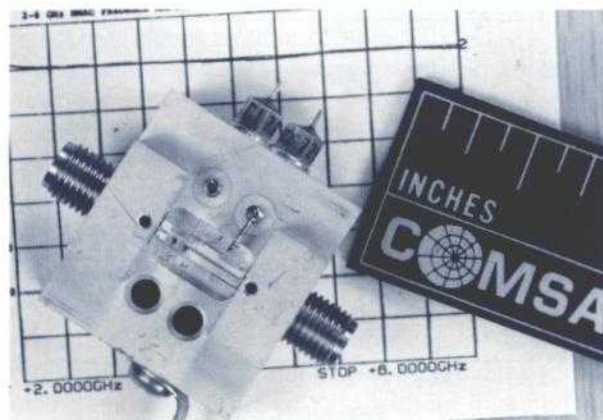

Figure 15. Feedback broadband amplifier uses quasimonolithic technology

K-Band Diplexer for COMSAT General

A dual polarized receive/single polarization transmit K_U-band feed system was designed and breadboarded. This diplexer was developed for use in the Hi-NET 4.5-m terminals, located at Holiday Inn motels. Primary design objectives for the feed system were compatibility with the existing Scientific Atlanta receive-only terminals and good performance with amenability to low-cost fabrication techniques.

The feed system design has been completed. When the schedule, quantities, and mounting requirements are defined, a tooling and fabrication study will commence. The fabrication and tuning cost of the feed is projected to be lower than the design goal.

COMSAT SUPPORT

Space Communications Division

Southbury Antenna Measurements

An extensive series of measurements was conducted on behalf of Maritime Systems at the Southbury, Connecticut, earth station complex to determine the modifications required to operate with the "Second Generation" space segment. Both the MARISAT and full performance antennas, low-noise amplifiers, and interfacility links were tested at L-band and in the 6- and 4-GHz bands. The principal intent of the measurement series was to evaluate the present operating conditions of the antennas to determine which components could be retained and which would have to



be replaced or retuned. This approach, which significantly reduces costs and minimizes station downtime, is an alternative to a complete retrofit of the stations.

Many of the measurements were straightforward. However, measurement of the on-site swept frequency feed system axial ratio required the design and fabrication of a special axial ratio test fixture that mounted between the subreflector and the corrugated feed horn.

Accurate radio star gain-to-noise temperature ratio (G/T) measurements were made at both L-band and C-band, by using the COMSAT Laboratories AMES, described previously.

Aeronautical Data Link Experiment

Mobile satellite systems such as INMARSAT may be the most attractive and effective means of implementing commercial transoceanic aeronautical voice and data communications. To test the feasibility of such a system and to examine the properties of the aeronautical satellite channel, COMSAT (Maritime Systems supported by COMSAT Laboratories) participated in a joint experiment with the MITRE Corporation, Rockwell International Corporation, Ball Aerospace Systems Division, and AvanteK, Inc. The general configuration of the demonstration experiment, performed during August 1985 and intended to evaluate operational performance for severe conditions at low-path elevation angles, and the actual flight test route are shown in Figure 16.

One of the most useful results was the discovery that multipath effects did not severely impair performance for most of the flight path. However, along the path segment north of Iceland, there was noticeable degradation in link performance, although communications were not lost. The BER distribution statistics indicate that the errors were uncorrelated, suggesting mostly diffuse multipath components. Other observed higher error concentrations, some of which exhibited a cyclical pattern, were attributed to inherent system impurities and differential PSK (DPSK) demodulator performance near threshold. It was also found that the system carrier-to-noise ratio was more sensitive to aircraft antenna gain pattern variations due to aircraft motions than to other experiment parameters.

The experimental results show that inexpensive low-gain modems can be practical and can serve the aeronautical community by substantially improving navigation accuracy, enhancing safety standards, and by facilitating other communications capabilities such as weather updates and public correspondence.

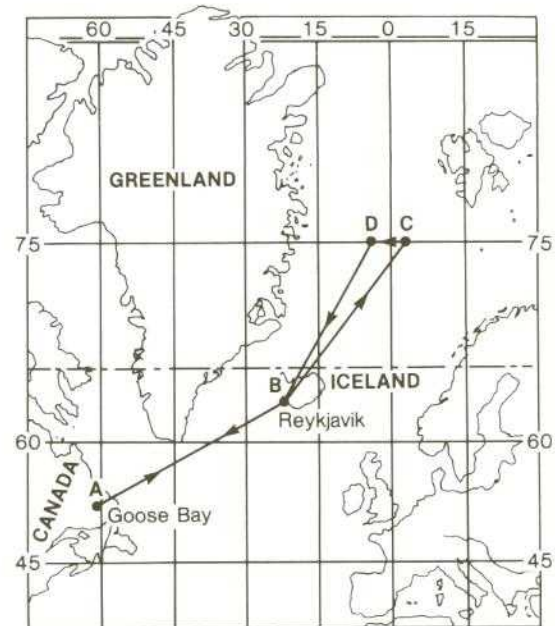
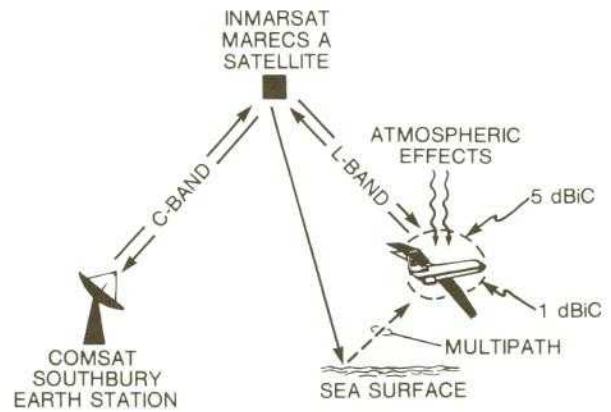

Figure 16. Aeronautical data link experiment evaluates performance of mobile satellite systems for severe conditions at low path elevation angles, using path shown

Global/Spot Beam System

The MTD investigated the techniques, feasibility, advantages and cost of modifying the INMARSAT II satellite to provide a spot-beam coverage. This investigation led to an efficient approach for modifying the present INMARSAT II antenna/transponder design. This approach, presented to INMARSAT through COMSAT's Maritime Services unit, adds spot-beam capability to the present all-global system with minimum additions to mass and power. The L-band

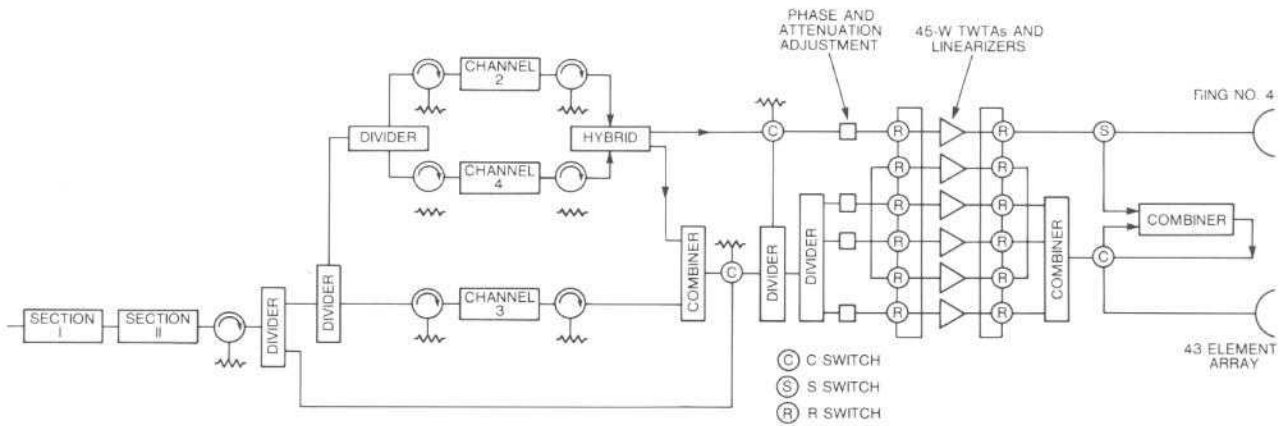

Figure 17. INMARSAT transponder configuration increases satellite capacity by more than 50 percent

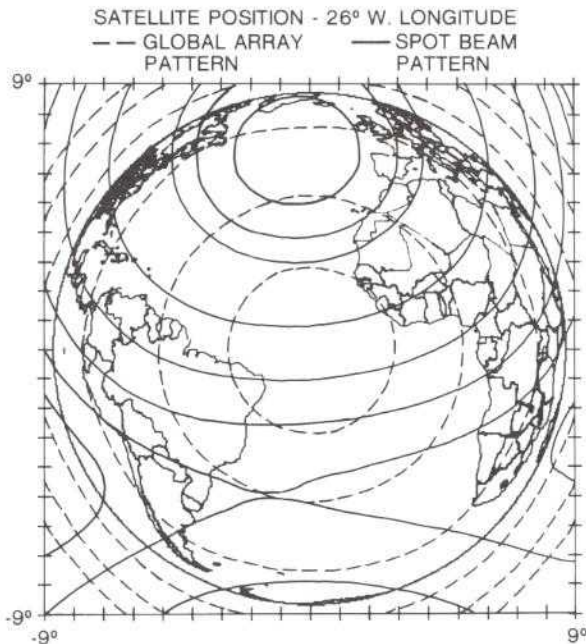

Figure 18. Global and spot beam contours are generated simultaneously by the same array

transmit antenna array presently used for global coverage, along with the same number of traveling wave tube amplifiers (TWTAs) in the transponder, is used to produce global and spot beams at the same time and thus increase the satellite capacity by more than

50 percent. Figure 17 is the transponder schematic, while Figure 18 shows typical global and spot-beam contours generated simultaneously by the same array.

The MTD also provided support for the monitoring of INMARSAT II communications payload fabrication by Hughes Aircraft Company.

COMSAT Technology Products

Antenna and Feed

In cooperation with the Network Products Division of Communications Technology Products (CTP), the MTD has developed a 1.8-m K_U -band offset reflector antenna system demonstrating superior sidelobe performance (see Figure 19). A K_U -band transmit and receive feed system consisting of a corrugated feed horn, halfwave polarizer, vertex orthomode transducer, and transmit bandpass and transmit reject filters was designed (see Figure 20). The feed components were specifically designed to be amenable to high-quantity/low-cost fabrication techniques such as die casting.

The superior sidelobe performance is a result of the offset reflector geometry which eliminates blockage, as well as the careful design of the corrugated feed horn illumination function and control of the rms surface tolerance of the reflector surface. Agreement between calculated and measured performance has been excellent.

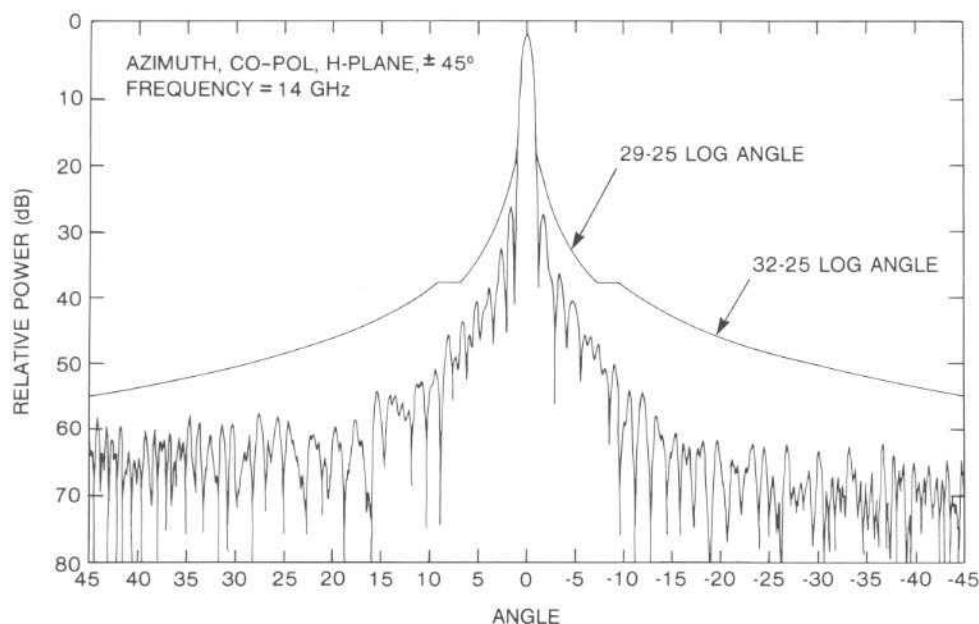

Figure 19. 1.8-m K_U -band offset reflector system demonstrates superior sidelobe performance

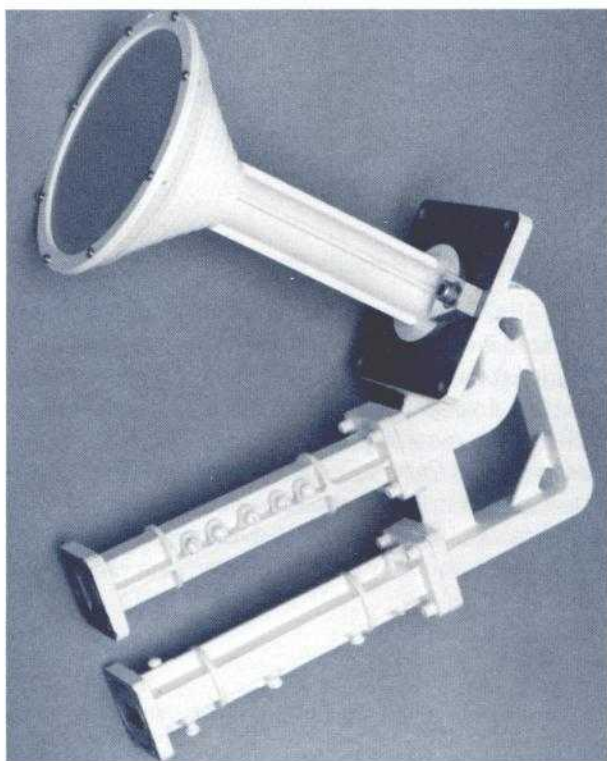

Figure 20. K_U -band feed system components are amenable to high-quantity/low-cost fabrication

INTERNATIONAL

Undersea Fiber-Optic Systems

The competitive position of satellite communications relative to that of fiber-optic systems in the Atlantic Regions was critically assessed. Studies of the current state-of-the-art and predictions of future trends provided the basis for cost estimates for point-to-point undersea communications and terrestrial extensions by fiber-optic cables to the International Switching Centers and the Bell operating companies. The satellite system alternatives were investigated by the Communications Technology Division.

INTELSAT

Optical Intersatellite Link

An on-board optical transceiver package for full-duplex 36-MHz analog or 360-Mbit/s digital transmission capability between two geosynchronous satellites spaced 60° apart was investigated under INTELSAT Contract INTEL-384. Six different optical systems using carbon dioxide (CO_2), neodymium-doped yttrium aluminum garnet (Nd:YAG), indium gallium arsenide phosphide (InGaAsP), and gallium



aluminum arsenide (GaAlAs) lasers were evaluated with respect to their performance characteristics, and mass, volume, and prime power requirements. As indicated in the final report submitted to INTELSAT, the GaAlAs systems offer the most potential. In the near term, a direct detection system with one or a few optical carriers in each direction seems practically feasible with power combining of two orthogonally polarized lasers. In the longer term, the use of optical heterodyne detection would probably be feasible with wavelength division multiplexing. This will require development of frequency stabilized GaAlAs lasers and associated drive circuits.

In-Orbit Test Set Upgrade

The objective of INTELSAT Contract INTEL-497 is to upgrade the INTELSAT V control software that runs the in-orbit tests (IOT) on the series V satellites. Both the original hardware and software were implemented by COMSAT Laboratories for INTELSAT. The upgrade will allow INTELSAT to perform IOT for the series V and V-A, as well as the V-B business system satellites, which use an expanded frequency band. To accommodate this band, INTELSAT modified its ground equipment hardware and COMSAT upgraded existing software so that it is compatible with the modified hardware while maintaining the existing user interface and measurement strategy.

Miniaturized Solid-State Power Amplifier Modules

The purpose of the program conducted for INTELSAT under Contract INTEL-454 is to investigate various approaches to the design and fabrication of miniaturized SSPAs which have simultaneously high efficiency and linearity. During Phase I, each of three different circuit approaches is being studied and breadboards designed and built. In Phase II, one of the approaches will be chosen and several multistage versions will be built in breadboard form. Finally, in Phase III, 15 amplifiers (30-dB gain each) will be built and evaluated.

Three basic approaches are being studied in Phase I:

- class B/AB operation
- negative feedback (in the Microelectronics Division)
- dynamic bias.

In all three cases, a quasimonolithic approach in which discrete FETs are combined with an otherwise

monolithic circuit is being used.

The class B/AB design has been completed and is being transferred to artwork. It is expected to deliver about 0.5 W with about 9-dB gain.

Tests are also in progress on both COMSAT-developed and commercially available FETs to evaluate the sensitivity of third-order intermodulation distortion and efficiency to DC bias levels.

Phased Array for Shaped Beams

Under Contract INTEL-428B with INTELSAT, the MTD performed analytical studies and will fabricate an experimental model to demonstrate the use of direct radiating phased arrays for reconfigurable shaped beams. The experimental model will have 64 radiating horn elements fed by active circuits consisting of variable phase shifters and variable gain amplifiers, which are in turn fed by a stripline power-dividing network. A digital controller will also be fabricated to reconfigure the shaped beam on command. In 1985, the key passive components, including ortho-mode transducers, radiating elements, and the beam-forming network, were built in breadboard form. Designs for the active MMIC modules (phase shifter, variable attenuator, and amplifiers) will be completed in 1986.

OTHER

RCA

Direct Broadcast Satellite Feeds

In 1984, two flight-qualified 12/17-GHz circularly polarized feed modules were built for use with a direct broadcast satellite (DBS). The inclusion of an additional up-link spot beam on the DBS satellite required building two more flight units. These units were completed and all four modules were integrated into the antenna feed array for the RCA satellite in 1985. The modules exhibited less than 0.6-dB axial ratio across the usable frequency bands.

GTE

In-Orbit Automatic Test Equipment

GTE Contract GD-83-010 for IOT Automatic Test Facilities was initiated in 1984. Work in 1985 consisted of further refining a very powerful interactive graphics

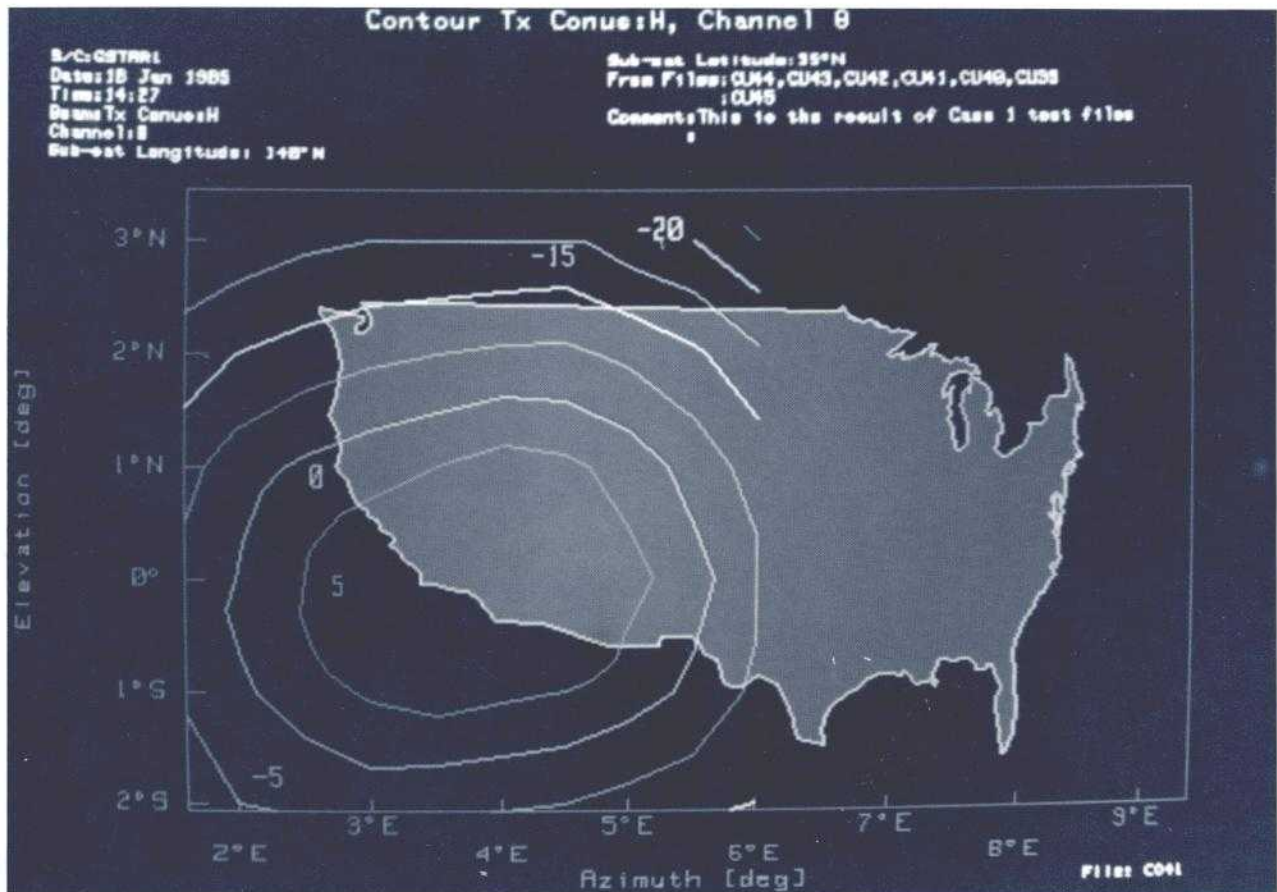

Figure 21. Antenna pattern and coverage area can be displayed in spacecraft or geometric coordinates

editor and implementing contour generating algorithms from sparse data. The editor and contour generator as well as database management comprise the antenna analysis package of the GTE facility, which can display antenna patterns together with the coverage region in either spacecraft (Figure 21) or geometric (earth) coordinates. Extensive documentation for both the IOT and antenna analysis packages was completed and delivered.

SBS

Antenna Measurement

An axial ratio study was performed on the Satellite Business Systems (SBS) 12.5-m IOT antenna at Castle Rock, Colorado, under Contract MTA-94. The

purpose of the measurement study was to evaluate the polarization performance of the antenna and recommend the necessary modifications to upgrade it for measuring the new SBS dual-polarized satellites. Selected tests were designed to characterize the polarization performance of the antenna without requiring removal of the feed or necessitating extensive down-time. A rotating RF probe assembly and subreflector absorber shield were designed and installed at Castle Rock to measure the on- and off-axis feed system axial ratio. With this assembly, accurate swept frequency axial ratio measurements of the installed feed system axial ratio were made. The results demonstrated that the antenna is capable of 40-dB axial ratio with a new four-port diplexer and polarizer while retaining the existing tracking system and corrugated feed horn. Measurements of the gain,



G/T, and antenna and low-noise amplifier (LNA) noise temperature of the SBS station were also made.

NASA

TDAS Laser Intersatellite Link

During 1985 a separate optical ISL study, "TDAS Laser Intersatellite Communications," was begun under subcontract 01232 with NASA Goddard Space Flight Center. The objectives of this study were to perform trade-off analyses of the optical power budget for various high-speed geosynchronous to geosynchronous (GEO-to-GEO) links (2 Gbit/s, satellites spaced 160° apart) and low earth orbit to geosynchronous (LEO-to-GEO) data links (1 Gbit/s) using semiconductor diode lasers, and to identify critical system parameters so that baseline configurations of the focal plane layout and complete systems designs including RF/optical interfaces could be made.

Power budget calculations for GEO-to-GEO and LEO-to-GEO forward and return links have been completed for the following modulation formats:

- on-off keying with Manchester coding and direct detection
- quaternary pulse-position modulation (QPPM) with direct detection
- quaternary frequency shift keying with heterodyne detection.

Link performance degradation due to solar conjunction on the GEO-to-GEO links and due to sunlit earth on the LEO-to-GEO links was estimated. The designs

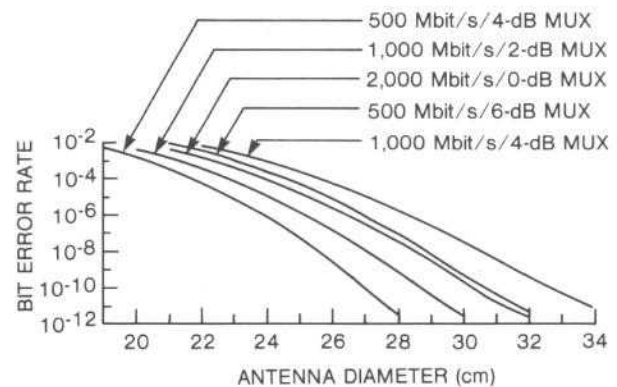

Figure 22. GEO-to-GEO crosslink: accumulated BER vs antenna diameter

of optical communications transceiver terminals were also completed. Figure 22 shows the typical results of optical power budget calculations for GaAlAs laser ISLs using QPPM with direct detection. A $0.85\text{-}\mu\text{m}$, 1-W optical transmitter was chosen for the 2-Gbit/s link to allow a 4-dB margin and $0.3\text{-}\mu\text{rad}$ noise equivalent angle in the system design.

The following work is planned to be completed by the summer of 1986:

- RF/optical interface definition and technological approach
- system control and monitoring concepts
- communications and command sequence from launch through orbital operation of TDAS satellites
- in-orbit communications test scheme
- a schedule for the hardware development phase.

MICROELECTRONICS DIVISION

INTRODUCTION

The mission of the Microelectronics Division (MED) is to perform research leading to the development of state-of-the-art microelectronic components for improved and expanded satellite communications systems and services and other aerospace applications. These components consist of discrete devices such as field effect transistors (FETs), microwave integrated circuits (MICs), miniaturized microwave active circuits (MMACs), monolithic microwave integrated circuits (MMICs), and digital integrated circuits. Efforts are directed toward improved electrical performance at higher frequencies and operating speeds and, of particular importance to spacecraft applications, enhanced life and reliability. Related to reliability is the investigation of radiation effects on both active and passive spacecraft components. Because of the importance of reliability, the division maintains an analytical facility that not only supports its own development projects, but also performs analytical services for other groups within the corporation.

FACILITIES

New Class-100 Clean Room

To fabricate MMICs with submicron geometry, a new clean room facility, shown in Figure 1, has been built. This facility enables critical microlithography processes to be conducted in a controlled clean environment, with a maximum of 100 half-micron particles per cubic foot. Several pieces of microlithography equipment have been installed, including an electron beam lithography system, a deep ultraviolet (UV) and an infrared mask aligner, and automated machines for photoresist coating and developing. In addition, a scanning electron microscope (SEM) has been installed for in-line monitoring, allowing devices and MMICs with submicron features to be fabricated with high quality and good yield. An additional thin film processing clean room facility, scheduled for completion in 1986, will further enhance the semiconductor processing facility.

Submicron Electron Beam Patterning

With the completion of the new class-100 clean room, the Cambridge Instruments, Inc. Electron Beam



Figure 1. Class-100 clean room permits fabrication of MMICs with submicron geometry.

Pattern Generator was relocated as shown in Figure 2. The programming graphics and jobfile preparation equipment were situated to improve utilization of the system and accelerate development of submicron devices and MMICs.

The patterning of wafers for development of half-micron gates has been accomplished exclusively using electron beam writing technology. This power FET and low-noise amplifier (LNA) development could not have been completed without the use of electron beam writing. Techniques were developed to provide fast turnaround (typically less than one day) for gate writing.

Development of the technology required to write 0.25-micron patterns in resist and to fabricate complete gate structures has been initiated, and integration with the remainder of device and circuit processing continues. Figure 3 shows a scanning electron micrograph of a completed quarter-micron gate structure.

Research has also begun to develop techniques for more accurately placing gates in ion-implanted

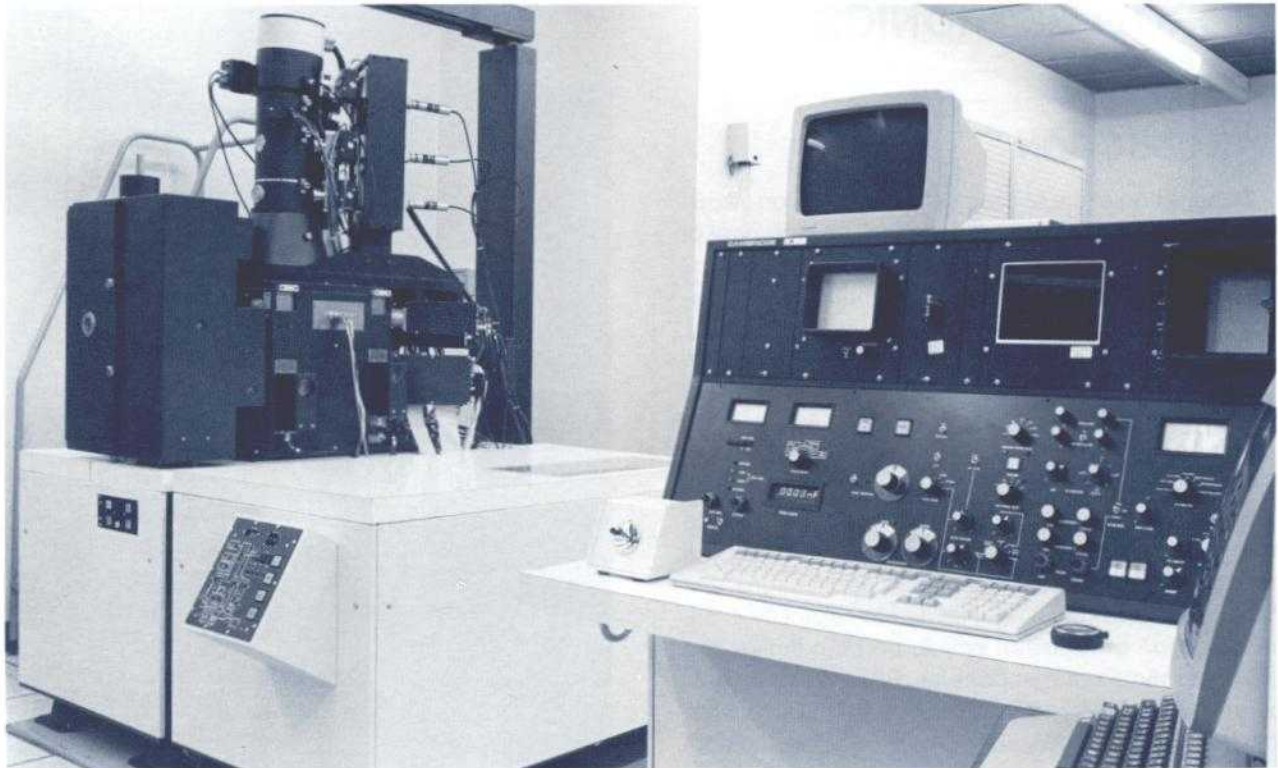

Figure 2. Operating console of the Cambridge Instruments, Inc., Electron Beam Pattern Generator

devices for low-noise applications without requiring electron beam writing on multiple levels. This process requires the combination of optical and electron

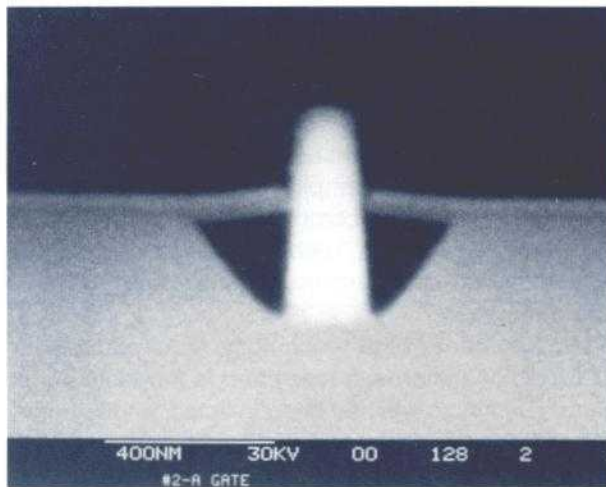

Figure 3. Quarter-micron, recessed, metal gate structure fabricated using electron beam lithography

beam technology and two layers of resist on the substrate at the same time. Initial experiments have been very promising and will permit the fabrication of better LNA MMICs and FETs. A technique is being investigated for the double exposure (optical and electron beam) of a single layer of polymethyl methacrylate (PMMA). This will significantly improve the writing time for MMICs having large area metallization on the gate level for capacitor baseplates. Experiments have proven that the double exposure and development of the single resist layer can be completed satisfactorily. Integration with the remainder of the gate formation process is under investigation.

Automated 50-mm-Diameter Halide GaAs Reactor

A computer-controlled halide epitaxial reactor with 50-mm-diameter gallium arsenide (GaAs) wafer capability was constructed and placed into operation during 1985. This reactor is shown in Figure 4. Wafers are processed singly with a maximum throughput of two wafers per 8-hour work day. The reactor design

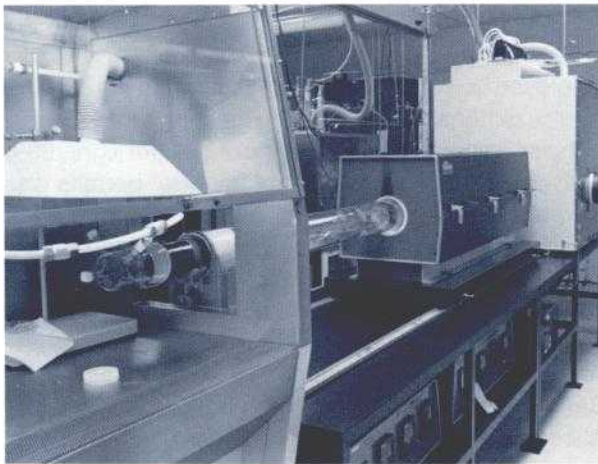

Figure 4. Computer-controlled halide epitaxial reactor for growing epitaxial layers on 50-mm-diameter GaAs wafers

permits the growth of layers with uniform electrical characteristics (I_{DSS} values vary by less than 8 percent from the average value) and reproducible and predictable characteristics from run to run. The addition of this reactor permits fabrication of state-of-the-art microwave devices and circuits from GaAs epitaxial layers on 50-mm-diameter wafers as opposed to the previously available 2×2 -cm² wafers. Aside from the advantage of obtaining more devices and/or circuits for each wafer, 50-mm-round wafers simplify fabrication steps involving lithography.

Molecular Beam Epitaxy System

A Riber molecular beam epitaxy (MBE) system, shown in Figure 5, was ordered in September 1985 for delivery in June 1986. The system will permit COMSAT Laboratories to develop the next generation of microwave and digital devices and circuits. The most promising of these are based on gallium arsenide/gallium aluminum arsenide (GaAs/GaAlAs), heterostructures. The high electron mobility transistor (HEMT) and heterojunction bipolar transistors have already demonstrated performance superior to that of the GaAs metal semiconductor FET (MESFET) for low-noise application. Theoretical formulations predict such devices will perform at frequencies in excess of 100 GHz.

The MBE system is computer controlled so that the deposition process permits extremely fine control of layer thickness (≤ 1 nm), layer abruptness (one mono-

layer), alloy composition, and multiple layer structures. This capability will allow the scientists at COMSAT Laboratories to produce novel materials with unique electrical and mechanical properties which are fundamental to the development of advanced semiconductor devices.

Inductively Coupled Plasma Facility

A sensitive new analytical capability was brought on line in 1985 with the installation of the Perkin-Elmer inductively coupled plasma (ICP) spectrometer. The ICP method is considered an "ultra trace" technique because its detection limit for most elements is about 1 to 100 parts per billion. The combination of an argon plasma high-temperature (8,000-K) excitation source and a sophisticated dual grating spectrometer gives higher sensitivity and speed than other emission techniques, and interference-free spectra for more than 70 elements. The instrument, shown in Figure 6, injects the liquid samples into the plasma, where they are excited to ionic species; the spectrometer measures the ionic emission intensities of elements being analyzed and compares them to standard emission intensities to yield the concentration of elements in the sample. The system operates under control of the Perkin-Elmer 7500 Series Professional Computer, which also coordinates automatic sample injection of as many as 50 samples from the autosampler. Typical applications of the ICP include analysis of trace contamination in water, chemicals, and other unknowns.

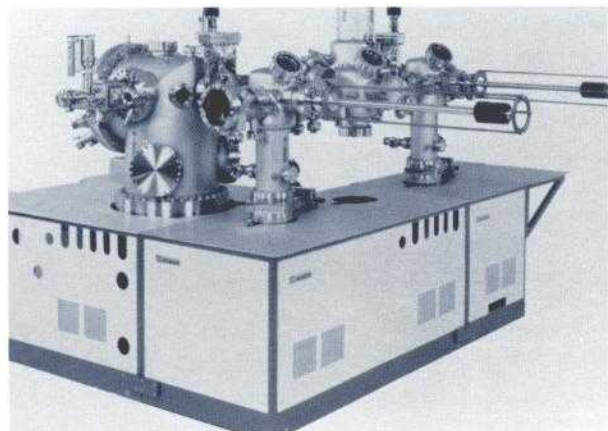

Figure 5. The Riber molecular beam epitaxy system will be used to develop the next generation of microwave and digital devices



Figure 6. Inductively coupled plasma emission spectroscopy system used for quantitative analysis of elements in concentration down to a few parts per billion

COMSAT R&D

Jurisdictional

Development of Millimeter-Wave Power FETs

Development of power FETs has made significant progress. In 1984, a device with a 1-micron gate length was reported. Using electron beam lithography, power FETs such as that shown in Figure 7 have now been fabricated with a nominal half-micron gate length and operated at 20 GHz. These devices have demonstrated state-of-the-art performance at 20 and 30 GHz, resulting from the achievement of 0.5- μm gate-length and epitaxial materials optimization for high power-added efficiency. The gates are fabricated using electron beam lithography directly on the GaAs wafer. Performance results shown in Figure 8 for a 1-W, 20-GHz and 4-dB-gain device represent state-of-the-art performance, greatly enhancing COMSAT's millimeter-wave capability.

Development of Millimeter-Wave Low-Noise FETs

Low-noise FETs for operation at frequencies up to 30 GHz or higher have been designed, and the lithographic maskset designed for use with epitaxial GaAs wafers has been delivered. The process for making quarter-micron, electron-beam-written gates is under development. Figure 9 shows one of the first FETs made using this maskset.

Epitaxial Semiconductor Technology Development

Halide GaAs epitaxial reactors have historically employed arsenic-saturated gallium melts as the source material from which the gallium is transported to the seed crystal. The use of pure gallium (0.999999) and equally pure arsenic trichloride permits the growth of the high-purity GaAs required for buffer layers. The epitaxial layer quality is very dependent upon the stability of the GaAs skin which floats on the arsenic-saturated gallium. Small variations in process parameters such as temperature and gas flow adversely affect the stability of this skin, and since the GaAs skin is not unconditionally stable, the characteristics of epitaxial layers deposited from it are not completely predictable.

In recent years, high-purity bulk-grown GaAs ingots have become available. As source material, these ingots are essentially insensitive to small changes in process parameters. In 1985, because of this advantage, high-purity bulk GaAs replaced the arsenic-saturated gallium source in both COMSAT's halide epitaxial reactors, as shown in Figure 10. The quality of the epitaxial layers grown using the solid source was found to be equal to or better than that grown using the gallium source. In addition, several advantages were quickly appreciated: the yield of usable material increased, the solid source material required recharging less frequently, and the solid source material is easier to work with.

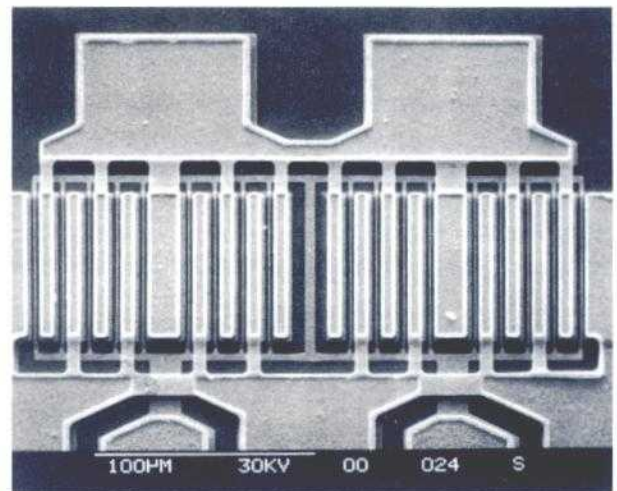

Figure 7. COMSAT Laboratories 20-GHz power FET was fabricated using electron beam lithography

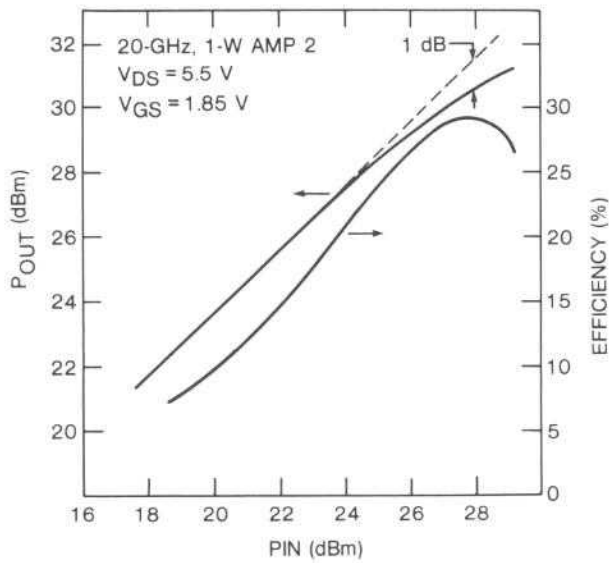

Figure 8. 20-GHz power amplifier exhibits state-of-the-art performance

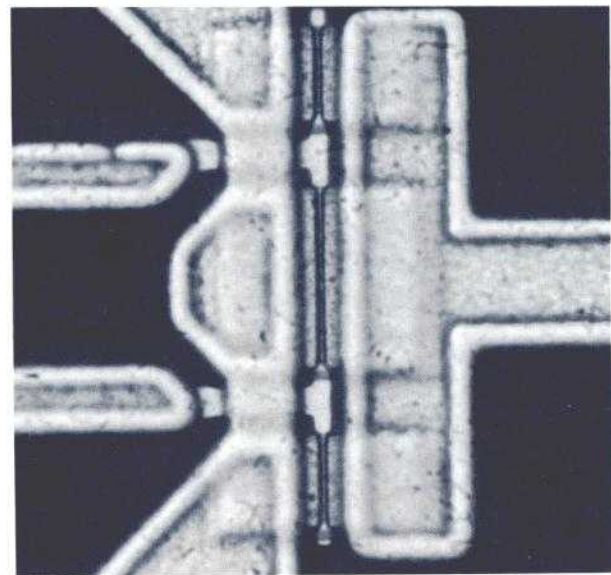

Figure 9. One of the millimeter-wave low-noise FETs designed in the MED

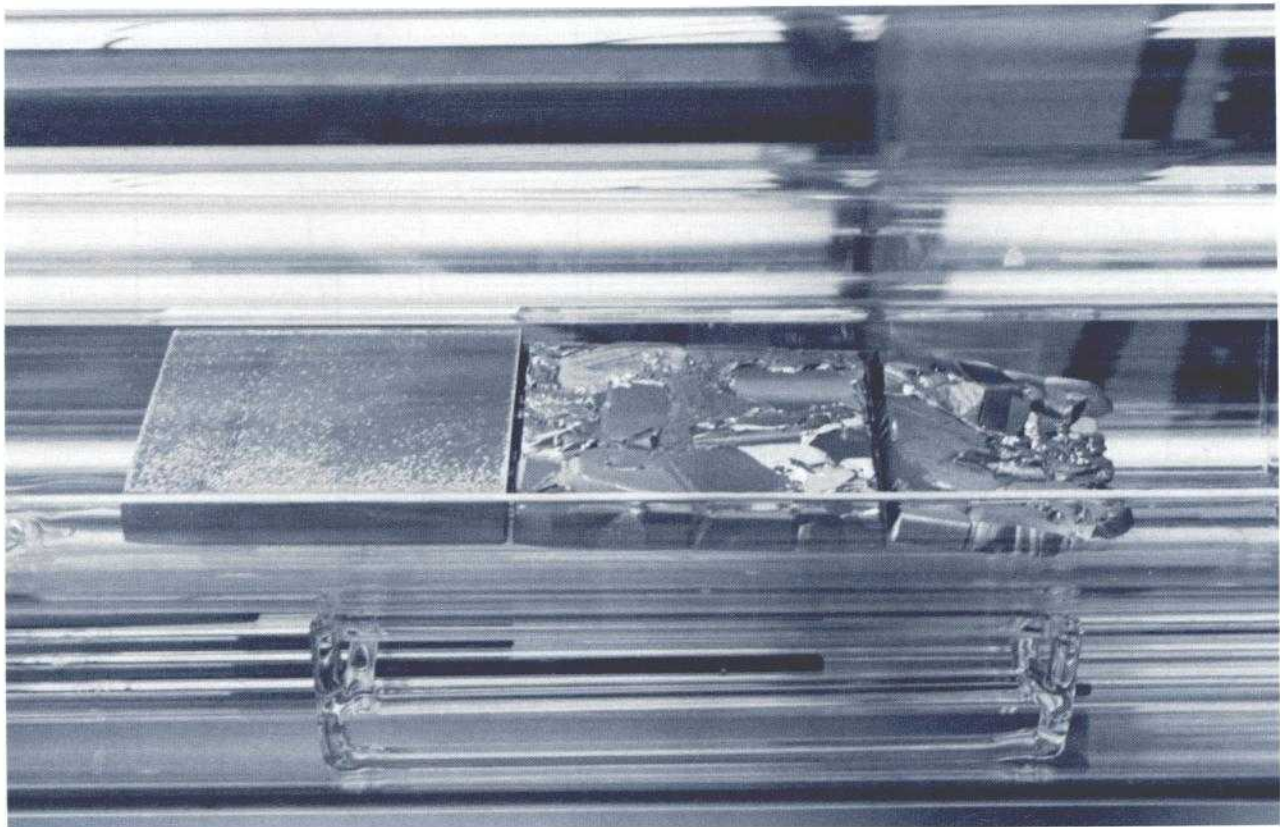

Figure 10. Solid GaAs source material is seen through the quartz wall of the epitaxial reactor



Ion Implant Semiconductor Technology

Fabrication of high-performance ion-implanted GaAs devices and integrated circuits requires good quality semi-insulating wafers into which the dopant is implanted. The characteristics of the active layer formed are directly related to the properties of the substrate material. An ongoing R&D effort to characterize GaAs material and qualify ingots for device fabrication has resulted in the establishment of an ion implant process that simulates many process steps used in circuit fabrication. A correlation between wafer properties and implanted layer characteristics was established. A set of wafer specifications was developed and implemented in procurement and acceptance of wafers. Important parameters in the specifications include mobility $\geq 5,000 \text{ cm}^2\text{V}^{-1}\text{s}^{-1}$, resistivity range of $1 \times 10^7 \leq \rho_s \leq 4 \times 10^7 \text{ } \Omega\text{-cm}$, and defect density $< 5 \times 10^4 \text{ cm}^{-2}$.

Characterization of ion implanted layers included measurements of parameters important in device design and performance such as ungated saturation current, I_{DSO} ; resistivity, ρ_s ; carrier mobility, μ_H ; carrier

profiles; and dopant activation, η . Table 1 summarizes data obtained on representative qualified ingots. Peak carrier concentrations measured from carrier profiles are listed in addition to values for the various parameters averaged over the sample wafers. Of particular significance in the table are the high carrier mobility, saturation current, and peak carrier concentrations, N_p , all of which compare very favorably with the upper limits achievable with the ion implant schedule used. The data indicate the acceptability of the starting material and confirmation of the material specifications. These results are used to provide device grade material and device design information for circuit fabrication and process monitoring.

In addition to the formation of active layers with good electrical transport properties, ion implantation offers the ability to tailor doping profiles important to device performance. A technique was successfully developed to adjust the position of maximum carrier concentration to coincide with the wafer surface by implanting through a silicon nitride layer. This technique provides an additional means to adjust and control device saturation current, I_{DSS} , and pinch-off

Table 1. Summary of Ion-Implanted GaAs Ingot Characteristics

Ingot No.	I_{DSO} (mA/mm)	ρ_s (Ω/\square)	μ_H ($\text{cm}^2\text{V}^{-1}\text{s}^{-1}$)	η (T)	N_p (cm^{-3})
1370 Slice 50	720	462	4,162	76	3.5E17
1370 Slice 156	736	407	4,251	82	3.5E17
3206 Slice 67	810	379	4,345	85	8.8E17
3206 Slice 168	803	412	4,184	83	3.9E17
860 Slice 9	752	398	4,257	83	3.5E17
860 Slice 140	680	407	4,227	80	3.5E17
789 Slice 9	677	471	4,065	80	3.8E17
789 Slice 105	774	392	4,273	88	3.9E17
Average Over Several Wafers	742	416	4,220	82	3.7E17



voltage, V_p , in conjunction with conventional recess etching. A typical carrier profile demonstrating this technique for a 100-keV, 6×10^{12} $\text{Si}^+\text{cm}^{-2}$ implant schedule and 700-Å-thick silicon nitride film is shown in Figure 11. Two carrier profiles are shown, one implanted into bare GaAs and the other through the silicon nitride film. This technique has been incorporated into the fabrication process for LNA circuits.

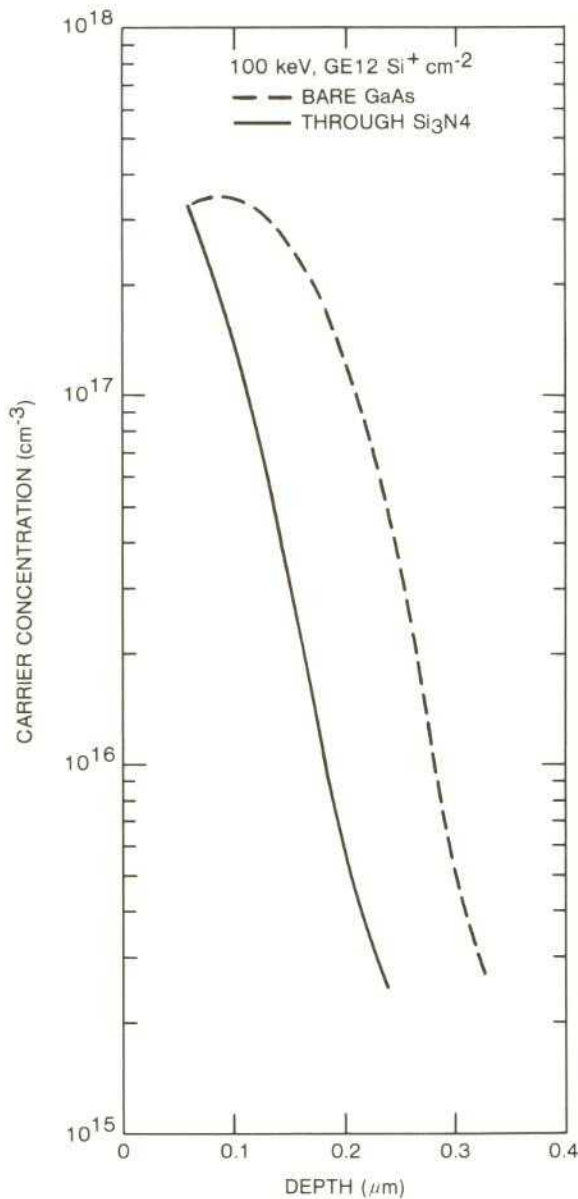

Figure 11. Two-carrier profile shows the effect of implanting through a silicon nitride layer

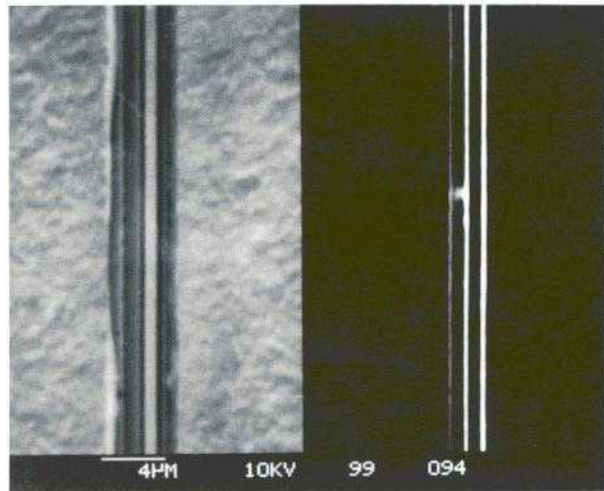

Figure 12. COMSAT-fabricated GaAs power FET operated near breakdown point
(a) Secondary electron image
(b) Electron-beam-induced current image

Electron Microscopy Techniques

A variation of scanning electron microscopy implemented during previous research at COMSAT Laboratories has been applied to in-situ analysis of voltage breakdown phenomena in GaAs FETs. The technique is known as electron beam-induced conductivity (EBIC) imaging. As the finely focused electron beam of the SEM is scanned over a biased FET, the current resulting from carriers induced in the semiconductor is conducted out of the vacuum system via electrical feedthroughs, amplified, and displayed in real time on a cathode ray tube (CRT). By raising the bias voltage on the FET to the onset of breakdown, it is possible to observe and record the formation of microplasmas in the semiconductor gap between the electrodes of the FET, e.g., gate and drain. Once the sites of microplasmas are identified in the EBIC image, as shown in Figure 12, further details about materials and device structure can be measured by other microanalytical means such as secondary electron, backscattered electron, X-ray emission, and Auger electron spectroscopy. Fed back to the design and fabrication engineers, these data relating device performance and analytical results have led to fabrication of GaAs devices which exhibit stable operation at higher bias voltages.

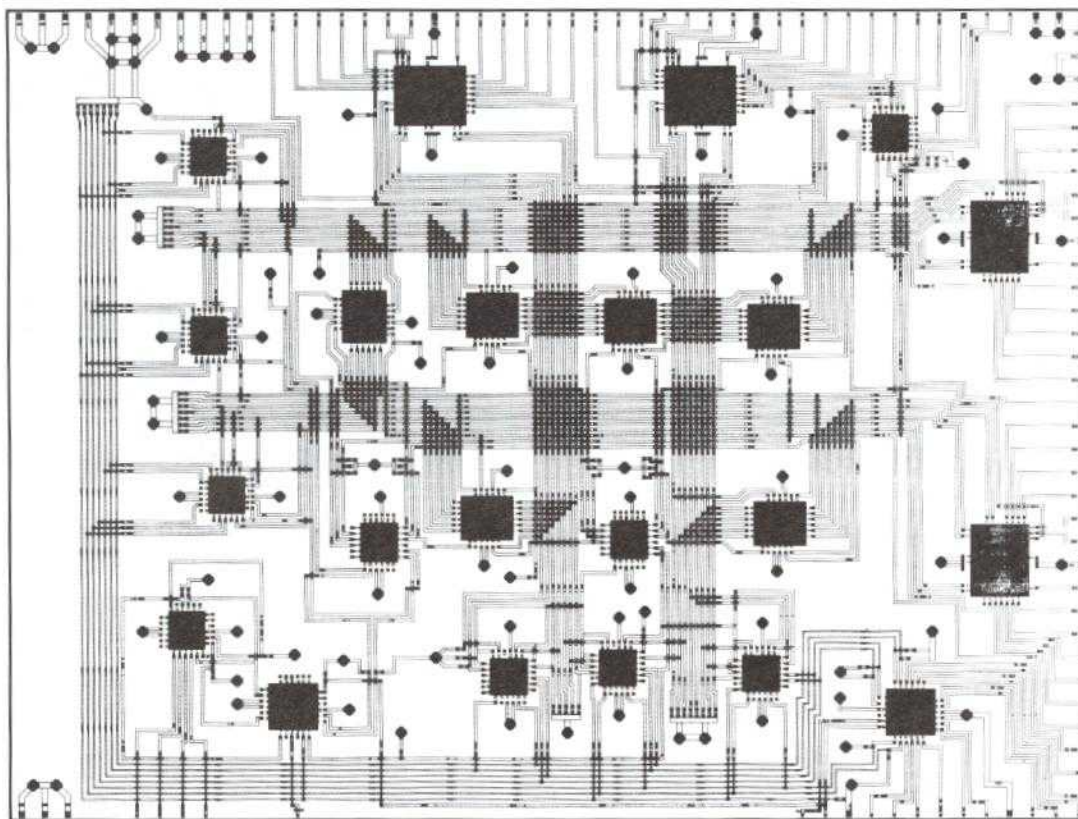

Figure 13. Add, compare, select hybrid integrated circuit for 140-Mbit/s modem

Computer-Aided Design

All of the masksets for the development of FET and MMIC technology for the Microelectronics and Microwave Technology Divisions were designed in-house. In particular, two masksets for five MMIC designs of 20- and 30-GHz power amplifiers and a combination of various types of switch and LNA circuits were completed for the Microwave Technology Division. The latter was particularly difficult as it contains several different size circuits on the same maskset.

A hybrid integrated circuit (HIC) has been designed for a coded octal phase-shift keying (COPSK) modem application of the Communication Techniques Division. The HIC is for the add, compare, select section of the modem and contains triple metal layer power and ground backplane, drilled and filled holes through ceramic substrate, and a double metal layer for signal interconnection on the top surface. This complex design was completed in record time with the masks fabricated and delivered prior to substrate delivery.

Figure 13 shows the front side metallization interconnections and the location of the emitter-coupled logic (ECL) chips to be bonded at assembly.

Non-Jurisdictional

Computer-Aided Device Modeling

A collection of computer programs has been developed to create a device modeling system designed to be user friendly, and flexible enough to accommodate the present and future needs of the MED. The system is invoked by running the master program named MODELSYS. The user supplies to MODELSYS the name of a specific model program (SMP), which may also call on other programs in the system. Interaction with the user is mainly through menus.

MAKEAFET is a particularly useful SMP because it is designed to predict the effects on performance of any changes in maskset design, materials parameters, and process parameters. Thus, it can be used for



troubleshooting, for process optimization, and for device design purposes. To enhance its usefulness for these purposes, and to help to verify the accuracy of the modeling, input parameters and computed performance parameters have been chosen to correspond to characterization measurements which can be made in the laboratory.

During initialization, MAKEAFET allows the user to specify three program names. It then executes these as part of the initialization process. One provides the basic material constants of the semiconductor. Another defines a particular device design which will typically correspond to a FET made using a particular maskset. The third program allows the user to specify a carrier profile. This is a very important, measurable material characteristic which can be established through controlled epitaxial growth or ion implantation and activation.

Figure 14 shows the User Option Table from MAKEAFET. Option 1 allows the carrier profile to be respecified without reinitializing the device design or semiconductor constants. Option 2 is for specification of materials parameters, and options 3 and 4 are for specification of geometric parameters. The gate recess depth is a particularly important geometric parameter which depends on the fabrication process. Option 5 allows the user to specify a set of gate recess depths, and then computes important DC and RF performance parameters for each depth. The remaining options shown are still under development.

COMSAT SUPPORT

Jurisdictional — INTELSAT Related

Space Communications Division

High-Energy Particle Tracks in Semiconductors

Damage from individual energetic ions has been observed in shallow junction solar cells at COMSAT Laboratories. Such damage had been considered impossible in semiconductors even though it is common in dielectrics. Cosmic rays constantly hit satellites in space; the damage track resulting from a single such collision with an integrated circuit could cause device failure and lead to loss of spacecraft performance.

Using a technique to triple the effective voltage of the MED 300-keV ion implant machine, the MED has

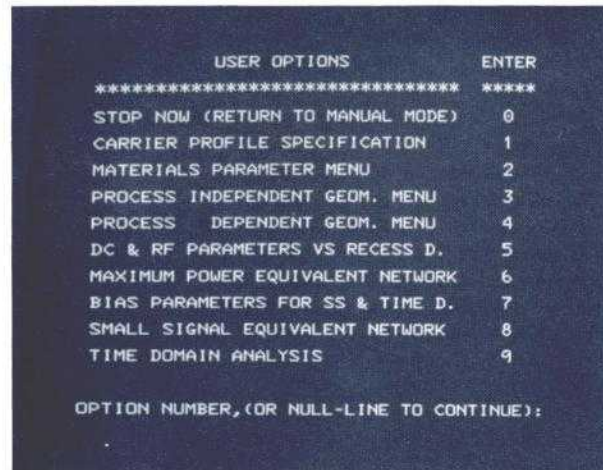

Figure 14. MAKEAFET's User Option Menu facilitates device modeling

accelerated triply ionized phosphorus to 810 keV and implanted these ions into 1-Ω-cm n/p silicon solar cells. The degradation of cell electrical characteristics was much greater than that expected from normal damage mechanisms. The electrical degradation was so great that observable damage from an individual ion was conjectured.

The COMSAT SEM, in the EBIC mode, was used to examine the implanted solar cells. Careful adjustment of the electron beam amplifiers collecting the induced current from the solar cell revealed dark spots in the induced current image (Figure 15) where ion damage

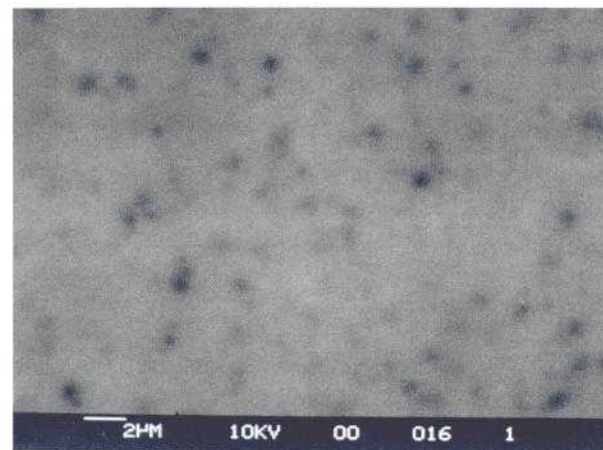

Figure 15. Electron-beam-induced current usage of silicon solar cell shows damage from 800-keV implanted ions



had reduced the number of carriers available for collection. The dark spots were as numerous as the implanted ions and did not appear in unimplanted samples. Surface studies using secondary electron emission showed that the dark spots were not the result of surface contamination.

The heavy damage from energetic ions (minority-carrier capture cross sections $> 0.5 \mu\text{m}^2$) was thus confirmed by the SEM results, which also confirmed the theoretical prediction that damage would be much less in $0.1\text{-}\Omega\text{-cm}$ material. However, a second damage mechanism observed electrically in these lower resistivity cells has not yet been seen in the SEM. Since this research impacts the reliability of future integrated circuits in space, further studies are being carried out to better define the nature and extent of this damage mechanism in silicon and to determine if it also occurs in GaAs.

Low-Temperature Radiation Hard Oxides

COMSAT Laboratories has developed a process for radiation hardening silicon dioxide films deposited at low temperatures (350°C). High-quality, radiation-resistant films are produced by etching the silicon surface prior to oxide deposition, by adding a dopant gas during deposition, and by an anneal step of 500°C after deposition. Experiments show dramatic reduction in voltage shift after radiation of COMSAT deposited oxide compared to that of typical non-radiation-hard oxides.

Oxide layers are used in most present silicon integrated circuits [not just in metal oxide semiconductor (MOS) devices]. These oxides are necessary for many of the structures being fabricated and for improved electrical characteristics. However, oxides are sensitive to radiation damage and therefore many such devices are inappropriate for space radiation environments. Oxides can be hardened by special techniques which normally require high-temperature ($>1,000^\circ\text{C}$) processes. Unfortunately for spacecraft designers, these processes are not utilized for commercial devices because of the higher cost and production changes required.

The COMSAT low-temperature, radiation-hardened oxide should appeal to manufacturers as a low-cost, process-compatible development. For most purposes, the dramatically decreased radiation sensitivity would be a relatively small advantage. However, if this oxide is incorporated into commercial devices, future spacecraft designs will be able to take advantage of the

variety and low cost of devices produced for a much larger market.

Further development of these low-temperature oxides in 1986 will broaden their application and better define the required process parameters. Reliability tests beyond radiation sensitivity will also be conducted.

Evaluation of Improved Radiation Shield

An engineering test on several types of semiconductor devices in several different radiation environments has demonstrated the effectiveness of a COMSAT-developed radiation shield. For devices that are very sensitive to radiation, the multimetal shield provides much better protection than presently available shields. With only a 20-percent increase in shield mass, an order-of-magnitude reduction in radiation dose has been confirmed in a space-like environment. The new shield permits the use of many commercial integrated circuits that would otherwise be unable to survive a 10-year mission in geosynchronous orbit.

Power Amplifier Development

There is an ever increasing need for K-band and millimeter-wave power amplifiers. With the $0.5\text{-}\mu\text{m}$ and $0.3\text{-}\mu\text{m}$ gate length technology within the MED, high-frequency power amplifiers were designed using both MIC and MMIC fabrication. Two MMIC power amplifiers were designed at 20 GHz (Figure 16) and 30 GHz for a variety of millimeter-wave applications.

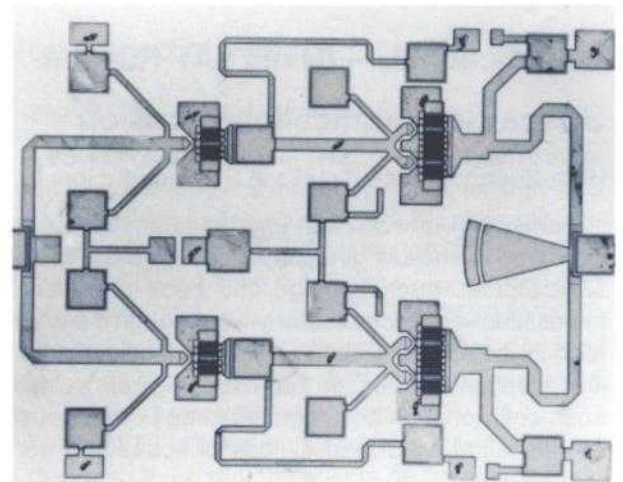

Figure 16. 20- and 30-GHz MMIC power amplifiers are fabricated on 100-micron-thick GaAs

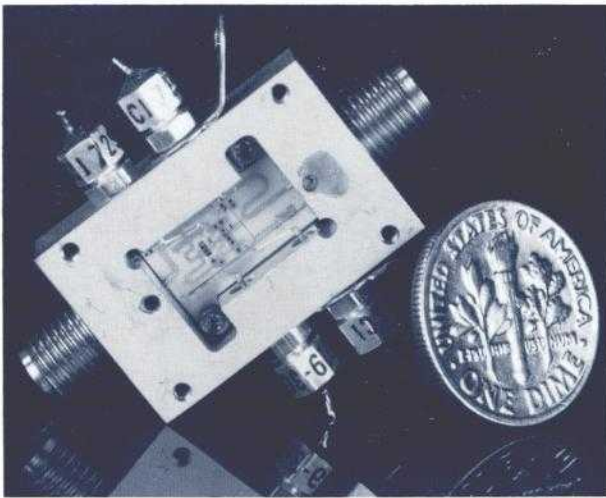

Figure 17. Proof-of-concept, C-band, feedback amplifier uses MMAC technology

These two circuits, which are being fabricated on 100-micron-thick GaAs, will achieve output power levels of 1 W at 20 GHz and 0.5 W at 30 GHz with a gain of 11 dB and 4 dB, respectively.

New circuit concepts can improve efficiency and linearity in power amplifiers. A proof-of-concept feedback amplifier is being fabricated at C-band using MMAC technology (Figure 17). This new design can improve the third-order intermodulation distortion by as much as 9 dB, which can greatly enhance the communication quality in applications requiring maximum output power for minimum possible hardware weight.

Class-B amplifiers can yield improved power-added efficiency. Computer modeling has been used to optimize GaAs FETs for Class-B operation. FETs fabricated according to the optimum parameters given by the model have in fact shown 29-percent power-added efficiency when operated Class-AB at 20 GHz. Further work is planned in this area.

Non-Jurisdictional

Communications Services Division

Low-Noise Power FET Evaluation

In support of COMSAT General, commercial semiconductor devices (low-noise and medium power GaAs FETs) being considered for use in the Satellite Business Systems flight hardware program were subjected to DC and RF evaluation. Since the FETs were

of a new design and were still undergoing space qualification, COMSAT Laboratories provided testing, analysis, and recommendations on the use of these devices.

COMSAT Technology Products, Inc.

MMAC Process Development

MMAC circuits allow high-quality microwave circuits, such as those shown in Figure 18, to be produced at low cost because all passive circuit elements, such as resistors, capacitors, and inductors, are deposited on ceramic substrates using photolithographic techniques, eliminating a large part of the assembly cost. The process development for Amplica has involved metal-insulator-metal (MIM) capacitor and via-hole interconnection technology. The plasma-enhanced chemical vapor-deposited (PECVD) silicon nitride has produced high Q-value dielectric with capacitance ranging from 100 to 500 pF/mm².

Product Development

As shown in Figure 18, several key microwave components were developed by COMSAT Laboratories for Amplica. New circuit concepts are being made possible by recently developed fabrication techniques which offer circuit designers new capabilities. A very broadband 2- to 18-GHz amplifier with a flat 6-dB gain, along with a 2-stage, 6- to 18-GHz amplifier with 8-dB gain, was developed in 1985 for Amplica. Three of these modules have been cascaded to make a 24-dB amplifier. These amplifier circuits have extremely compact dimensions (140 mils x 140 mils) and use very low-cost FETs. MMAC technology was applied to the fabrication of a 6- to 18-GHz Lange coupler, which considerably reduces the assembly time for balanced amplifiers, since the MMAC air bridges on the coupler eliminate the need for bond wires.

Other broadband components are being developed, including a 0.5-W, 12- to 18-GHz power amplifier, and a 2- to 18-GHz power amplifier. These prototype amplifiers and those to be delivered in 1986 will help to accelerate Amplica's new product development program.

Failure Analysis of Ceramic Chip Capacitors

The failure analysis expertise of the MED is available to all Corporate divisions. As an example, a failure analysis of ceramic chip capacitors used in MIC assembly was performed for Amplica. One lot of

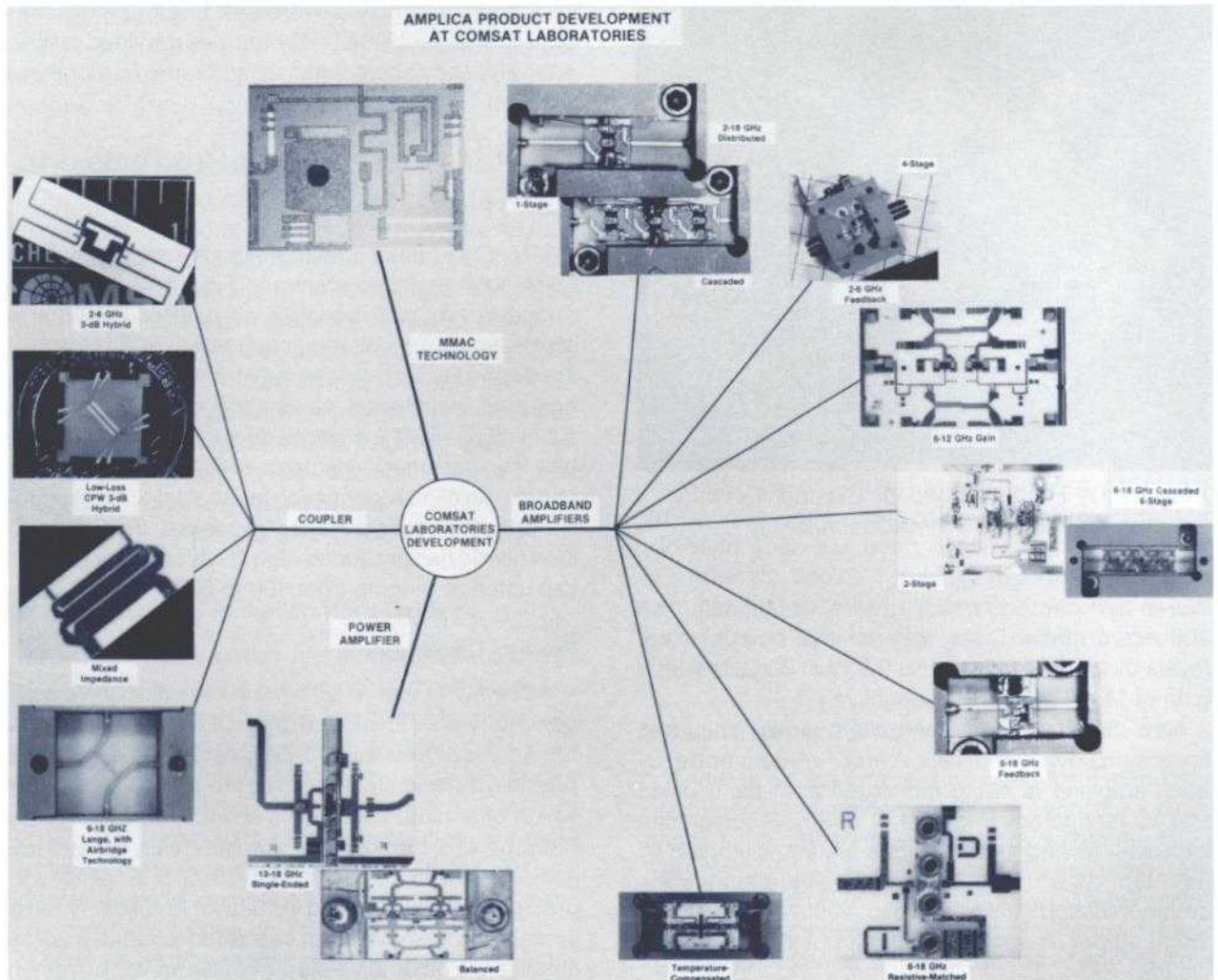

Figure 18. Several key microwave components developed at COMSAT Laboratories for Amplica

0.1- μF capacitors, each purchased part less than 2.5 mm in size, failed quality control inspection due to minute surface cracks 5 μm wide (see Figures 19a and 19b). Analysis of the problem by cross-sectional backscattered electron microscopy (Figure 19c) indicated that the cracks occurred during manufacturing (a vendor problem), when the ceramic/metal sandwich, while in a soft or "green" state, was coined by a punch and die. This pressure caused the outer ceramic layer to bend and fracture. Later hardening of the ceramic layer in a high-temperature operation arrested the propagation of the crack at the depth of the first electrode layer. However, MIL standards used for critical parts selection reject ceramic chip

capacitors if any internal electrodes are exposed by penetrating cracks or voids. In this case, replacement parts were ordered.

INTELSAT

Special Contracts

Power FET Evaluation

C-band power FETs developed with different doping profiles by another manufacturer were subjected to RF and DC performance testing for INTELSAT



under Contract INTEL-485. COMSAT conducted load-pull characterization, output power, and gain and efficiency performance testing. The FETs were divided into three categories by doping profile: flat, $1/x^3$, and spiked profile. COMSAT provided analysis of the RF performance as a function of these different processing parameters.

System Comparison of SSPA and TWTA

Under contract INTEL-485, a 10-W C-band SSPA was unit-level tested and then measured at the system level in cooperation with the Communications Techniques Division using the INTELSAT V simulator. The unit level RF performance data were obtained using the MED AMPAC measurement system. Nonlinear parameters, such as third-order intermodulation products, power-added efficiency, and AM-to-PM transfer, were evaluated.

System level tests included noise power ratio, modulation transfer, and companded single-sideband (CSSB) carrier intermodulation measurements. An INTELSAT V simulator transponder was configured with a traveling wave tube amplifier (TWTA) and characterized. Then the TWTA was replaced by the solid-state power amplifier (SSPA) and system performance

compared. The noise power ratio results showed that the SSPA clearly provides more linearity than the TWTA. The modulation transfer measurements indicate that the SSPA can achieve equivalent bit error rate results with approximately 1.1 dB lower E_b/N_0 than the TWTA. This implies that an 8-W SSPA has the equivalent communications capacity of a 10-W TWTA. The CSSB measurements show that the SSPA should provide additional channel capacity over the TWTA.

Support

Metallurgical Analysis of Ni/H₂ Battery Cases

During 1985, current leakage between the electrode stack and the case, resulting in cell discharge, was noted in the in-orbit performance of the INTELSAT V nickel-hydrogen batteries. In collaboration with the Spacecraft Technology Division, electrochemists and corrosion specialists at the National Bureau of Standards and materials scientists in the MED assisted in defining the failure mechanism. It was determined that unexpected cathodic corrosion of the Inconel battery case with localized dissolution and cratering of the thin metal wall had occurred.

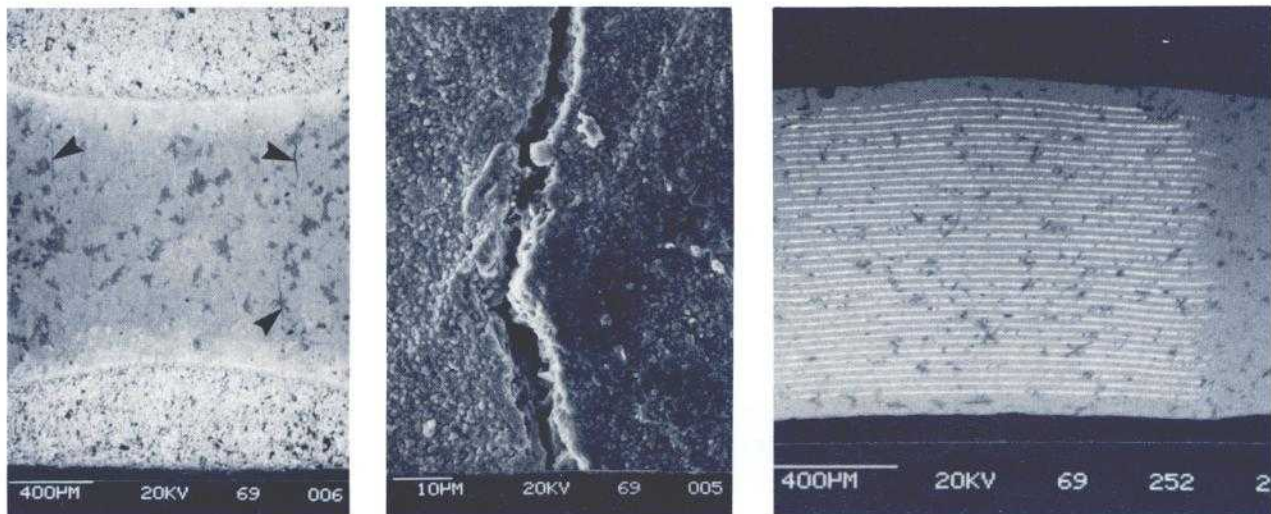

(a) Macrograph: arrows show surface cracks

(b) Closeup of a 0.002-inch crack

(c) Cross section of (a) indicates that the cracks extend through the surface defect to the first metal electrode

Figure 19. Failure analysis of 0.1- μ F ceramic chip capacitor reveals manufacturing problem



(a) Ductile (high-strength) failure resembles pulled taffy (350X)



(b) Brittle (low-strength) failure has granular appearance (350X)

Figure 20. SEM images of the fracture surface of Inconel alloy 718 following corrosion studies of Ni/H₂ battery cases define failure mechanism

In order to assess the potential impact of this new failure mode on spacecraft battery life, a set of experiments was devised involving a controlled exposure of the Inconel metal to chemical and electrical parameters simulating actual battery life conditions, followed by tensile tests and analyses for evidence of chemical attack that might weaken the battery case. Microscopic examination of the fracture surfaces of the experimental pull test samples identified the major failure mode as ductile fracture commensurate with high tensile strength, as shown in Figure 20a. Figure 20b shows a minor failure mode of brittle fracture associated with low tensile strength, which was limited to the surface region. As a result of this effort, revised battery management procedures were implemented on the satellites with the expectation that the batteries will now serve their original expected lifetime.

Failure Analysis of Ni/H₂ Positive Electrodes

In 1985 another INTELSAT battery materials problem was addressed, this one associated with INTELSAT VI. After a long period of storage, some of the positive Ni/H₂ battery plates developed green spots composed of an unknown, amorphous material. A combination of chemical analytical tests performed by the MED showed that the green material, which

had the morphology of cracked mud (Figure 21a), consisted of an unusual form of nickel-oxy-hydroxide having a higher oxide state than nickel hydroxide, a normal constituent of the positive plate. The oxide states of the hydroxides were analytically determined by using X-ray-excited electron spectroscopy to measure the binding energies of the molecular components at various places on the plate surface.

Further clues to the cause of the high nickel oxide state were revealed by Auger electron spectroscopy which indicated that there was a chloride contaminant concentrated in the microfissures of the green material (Figure 21b) and at the plate surface beneath the superficial green deposit. Under the contamination spots, corrosion of the positive plate was also documented. INTELSAT and the battery plate subcontractor have subsequently been apprised of the nature and potential consequences of the chloride contaminant problem and they are taking action to ensure that the life and performance of future INTELSAT VI batteries are not jeopardized by the effects of positive plate contamination.

INTELSAT VI Flight Hardware Evaluation

The MED's Automated Microwave Power Amplification Characterization (AMPAC) system, shown in

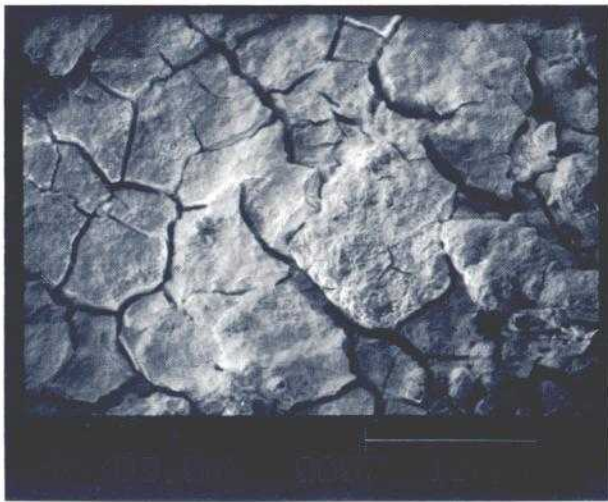

(a) Secondary electron image showing cracked mud appearance of green material

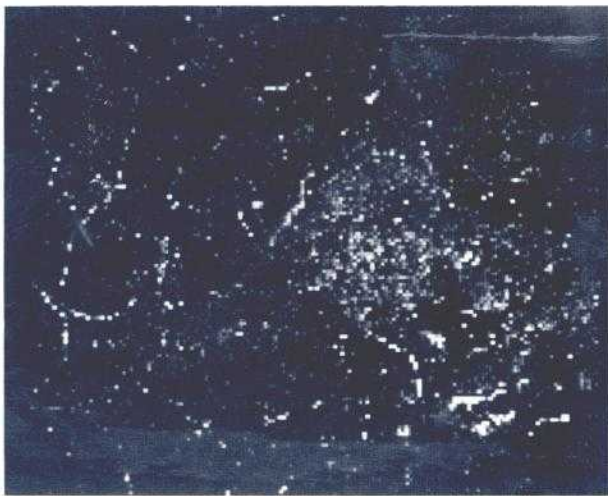

(b) Corresponding Auger electron map of chlorine

Figure 21. Secondary electron image and Auger analysis reveal chlorine in the microfissures of the green material on INTELSAT VI positive Ni/H₂ battery plate

Figure 22, consists of automated test equipment for the characterization of microwave power amplifiers and measurement control software developed at COMSAT Laboratories. In support of INTELSAT VI flight hardware development and manufacture, the AMPAC system was used to perform RF testing of INTELSAT VI SSPAs, TWTAs, and receivers. Equipment

destined for the INTELSAT VI spacecraft simulation was unit-level tested for adherence to INTELSAT performance specifications. Measurements such as power, phase shift, efficiency, voltage standing wave ratio, noise power ratio, AM/PM transfer, and intermodulation products were performed. Thermally sensitive parameters such as noise figure and gain slope were obtained through temperature cycle testing. All measured data and graphics are well documented in computer files.

Reliability Analysis of INTELSAT VI Solder Joint

The long-term reliability of a miniature electrical feedthrough for INTELSAT VI spacecraft became problematical with the discovery of the potential for formation of brittle intermetallic compounds of gold and tin in the solder joint. The MED electron probe microanalyzer was used to quantitatively analyze micron sized regions of the suspect solder joint following metallographic preparation of a cross section of the part. In the fillet on the feedthrough pin, three gold-tin (AuSn) compounds were identified by the microanalysis: AuSn, AuSn₂ and AuSn₄. The quantities and distribution of the compounds were determined along the solder/pin interface, but only at the fillet were there any measurable amounts of intermetallic compounds. From these data it was concluded that, although in general it is poor practice to solder a gold-plated pin without pretinning, in this case there was an ample



Figure 22. COMSAT Laboratories AMPAC system used for characterization of microwave power amplifiers and measurement control software



amount of solder to completely react with the thin gold layer and, further, that there is negligible chance of any additional formation of intermetallic compounds during the future life of the component.

Failure Analysis of INTELSAT VI Thrusters

INTELSAT VI spacecraft are being equipped with bipropellant thrusters which will use hydrazine fuel and nitrous oxide oxidizer. All previous INTELSAT satellites have used only monopropellant hydrazine thrusters. During hot-fire qualification tests of the INTELSAT VI thrusters by the subcontractor, some anomalies were detected which were potentially detrimental to the integrity and reliability of the thrusters. The major concern was the increased oxidizer pressure across the oxidizer orifices. In a few cases, there was burnout of the weld joint used to secure the titanium insert into the columbium faceplate. To help resolve the problem, COMSAT assembled a team from the El Segundo office, the Spacecraft Technology Division, and the MED, which assisted Hughes Aerospace Corp. and the subcontractor in analyzing the thruster design, materials choice, and weld schedules.

Thermal and stress analyses were performed and the parameters were defined which caused corrosion and oxidation of columbium and deposits of foreign material in the oxidizer orifices. The subcontractor instituted revised weld and machining schedules for

the faceplate which improved its integrity, resistance to corrosion, and thermal control. Hot-fire qualification tests with the improved design have demonstrated the success of the effort.

OTHER

Opto-Electronic Device Fabrication

Under Contract MDA904-86-M-6264 MPO to the Maryland Procurement Office of the Department of Defense, the MED has fabricated and delivered GaAs/AlGaAs solid-state laser diodes. These were made using MBE wafers furnished by the Government.

GaAs FET Chips Supplied for Evaluation

COMSAT has begun to supply a number of GaAs FET chips to potential customers for evaluation to explore the possibility of joint bidding with the established system houses on Department of Defense programs. Both X-band MMIC LNAs and power FETs have been supplied to Westinghouse, and 20-GHz power FET modules to TRW. The responses are quite positive. In fact, TRW has not only verified COMSAT's results at 20 GHz, but also in some cases claims to have seen better results on the same unit. This reflects COMSAT's conservative approach to quoting its results.

SPACECRAFT TECHNOLOGY DIVISION

INTRODUCTION

The Spacecraft Technology Division (STD) provides a broad range of engineering capabilities from controls, dynamics, and propulsion, to telemetry, tracking and command (TT&C), as well as structures, mechanisms, materials, thermal control, power systems, power electronics and solar energy storage, reliability and quality assurance, space environmental testing, and flight qualification. The division conducts R&D directed at improving satellite reliability, extending satellite lifetime, and advancing communications antenna technology. Activities include providing in-depth analysis and test support throughout COMSAT as well as under contract to INTELSAT and others.

Significant accomplishments for 1985 include R&D efforts in multibeam antenna technology, secure command systems, and momentum wheel bearing cage instability, as well as continued work on the hydrogen/nickel oxide (H_2/NiO) battery for the Department of Energy. The STD provided extensive support to both the INTELSAT VI satellite program at Hughes Aircraft and the Satellite Television Corporation satellite program at RCA. Members of the division staff carried out structural analyses and testing of the STARCOM 1.8-m antenna for COMSAT Technology Products, Inc., and completed a 600-cycle thermal vacuum test of a 220-W qualification model traveling wave tube amplifier (TWT) for Hughes Electron Dynamics Division.

COMSAT R&D

Jurisdictional — INTELSAT Related

Spacecraft Reliability Studies

During 1985, a program directed toward improving reliability analysis techniques, developing standardized procedures for product assurance programs, and providing state-of-the-art information on parts and materials was continued. The reliability analysis techniques that were developed and implemented included a computerized MIL-HDBK-217 prediction program, a computerized block diagram plus reliability prediction curve programs, and a library of data for

use in performing availability analyses. Product assurance procedures were updated and published to provide better and more cost-effective quality assurance, workmanship, and inspection requirements and programs. Data banks derived from participation in industry working groups and special tests were maintained and updated for parts radiation effects, materials properties, and parts application information.

Computerized Spacecraft Analysis

In 1984, the Computerized Spacecraft Analysis task was initiated to organize the computer software developed by the STD. A Software Library Program Catalog was produced, identifying some 76 programs used to design, analyze, evaluate, predict, and monitor spacecraft subsystems and components.

The Computerized Spacecraft Analysis task was continued in 1985 to improve the overall software capabilities of the STD. To take advantage of PATRAN-G, the capabilities of the major analysis programs were evaluated and enhanced where applicable through modification and conversion to a VAX 11/780 computer. PATRAN-G is an interactive, finite element pre-processor for creating geometric models for structural, dynamic, and thermal analyses and a postprocessor for graphically displaying the analytical results. Through this integration of programs, many labor-intensive methods were improved and made more efficient.

Several solar array and battery performance programs have been developed at COMSAT Laboratories which incorporate SPEAKEASY graphics. In addition, many industry standard computer programs such as NASTRAN, NBOD2, SINDA, TRASYS, DISCOS, and IGSPICE are in use. Some of these programs were enhanced with additional capabilities to meet specific requirements.

Through this effort an expensive software library was created as the focal point for computer program development, improvement, and maintenance.

TWT Quality Technology

During 1984, the life testing of space TWTAs was consolidated in a dedicated life-test area, and testing of six model 261H C-band TWTAs was brought under computer control. Two K_u -band TWTAs (with INTELSAT V-A TWTs, model TH 3559A) were mounted in a rack and equipped with sensors so that

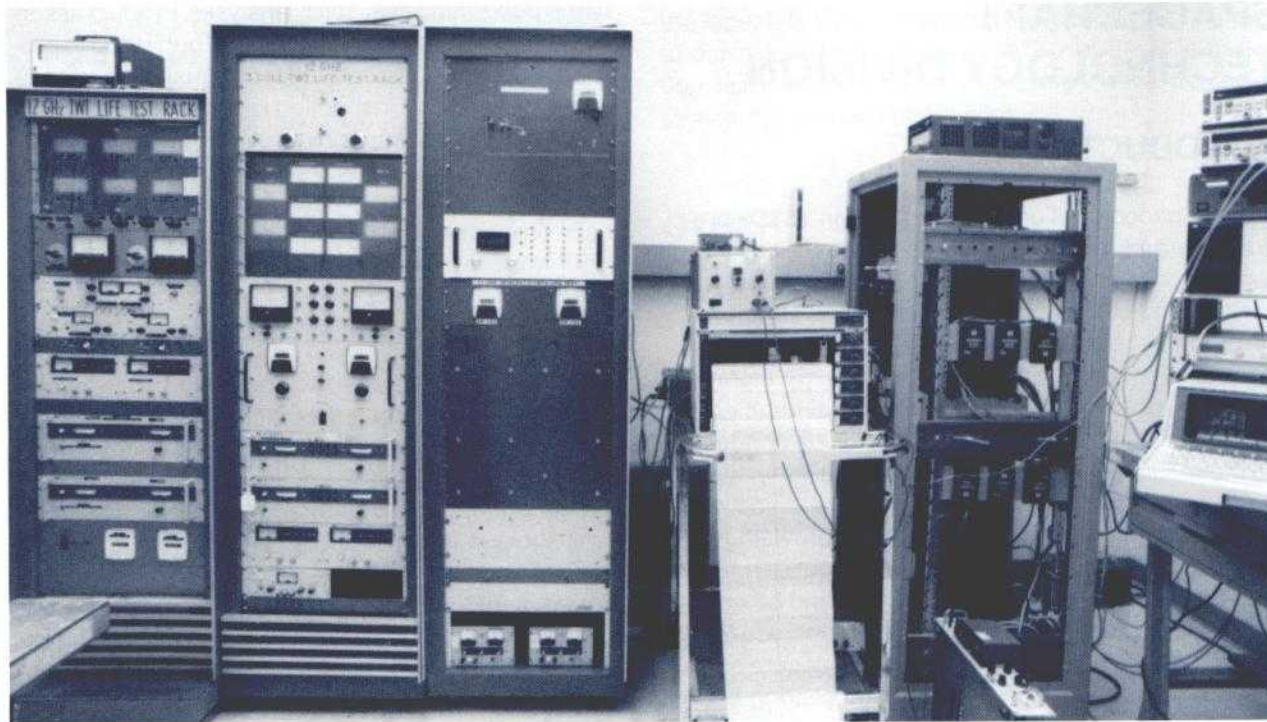

Figure 1. TWT life-test facility operates under computer control

measurements are made regularly under control of an HP87 computer, as shown in Figure 1.

In 1985, the C-band TWT life tests were interrupted to conduct a series of measurements on cathode activity. One of the TWTs appeared to be reaching end of life, with the cathode current starting to fall rapidly. After a series of measurements which involved varying the cathode temperature over a considerable range, the cathode current revived and the TWT is still operating adequately.

The two K_u -band TWTs are of interest since the cathodes are operated at an intermediate temperature between the value originally set for INTELSAT V operation and that determined for spacecraft F-13 through F-15. The anode voltage, which is automatically adjusted by the electronic power conditioner to maintain constant cathode current, is an excellent measure of the cathode state. In SN18 the voltage had been increasing at a rate twice that budgeted for the first 10,000 hours, which did not bode well for a 7-year life. However, at 16,000 hours, the rate of increase showed signs of leveling. Measurements such as these were useful in responding to the Ford Aerospace proposed modifications to INTELSAT V-A, which would have

involved sacrificing some of the TWT redundancy to allow parallel operation of TWTs in certain channels.

Power Conditioner for Solid-State Power Amplifier

During 1984, an engineering model of a lightweight power conditioner for a 10-W RF solid-state power amplifier (SSPA) was completed. A follow-on project was initiated to investigate converter concepts utilizing very high switching frequencies to reduce power conditioner size and weight, an advantage for distributed systems which may be used in multibeam antennas. Breadboards were designed and constructed for "Class E" and "resonant buck" units operating at greater than 1 MHz. Unit efficiencies exceeded 70 percent while power density is projected to exceed 120 W/kg for a 6-W output converter for a 2-W RF output SSPA.

In addition, circuitry was designed which allows gallium arsenide (GaAs) monolithic microwave integrated circuits (MMICs) to be controlled by external transistor-transistor logic (TTL) compatible signals. This circuitry will be integrated with the microwave circuitry.



Multibeam Antenna

As part of the multibeam antenna project, the STD developed thermal and mechanical design concepts for the K_U-band satellite multibeam antenna being designed by the Microwave Technology Division for use with SSPAs. Thermal control of the multibeam antenna is critical because the SSPAs are located in the waveguide directly behind the closely packed feed horns, resulting in a high concentration of heat. The SSPA is mounted directly to a heat pipe which carries the dissipated heat to a remote thermal radiator for rejection to space, providing a mechanical solution to the problem as well as permitting removal of any element in the array without disassembling the entire feed system. In 1985, mechanical and thermal analyses were performed which analytically demonstrated the feasibility of this design, as shown in Figure 2. Heat pipe performance was measured using a heat pipe with a similar construction to that proposed for the multibeam antenna configuration. In addition, electrical power requirements were integrated into the overall design and the design and development of the digital controller was continued.

Secure Command System

In conjunction with the Communications Techniques Division, the STD performed an in-depth study of secure command systems. This study emphasized

the use of various types of spread-spectrum techniques to ensure the ability to command spacecraft in the presence of significant jamming and the need for encryption to effectively counteract undesired commanding. Levels of threat, system issues, and evaluation criteria were established. Alternative systems were analyzed and compared and a hardware development program was defined which is keyed to the use of an existing demonstration model of a satellite-encrypted command system designed, developed, and tested by the STD. This system, based on a hybrid of the one-time pad and the Data Encryption Standard cipher systems method, consists of a microcomputer-based command generator/encrypter and a satellite decrypter implemented with complementary metal oxide semiconductor (CMOS) and bipolar logic integrated circuits. This general purpose data encryption system was designed to be radiation tolerant, to operate at high speed, and to consume low power.

Momentum Wheel Bearing Cage Instability

Life expectancy and reliability of bearings in rotating devices carried aboard spacecraft have long been major concerns of satellite system program managers. During 1985, design studies of momentum wheel ball bearing cages were conducted to identify factors critical to stable cage design and to determine how to optimize those factors to yield the most stable

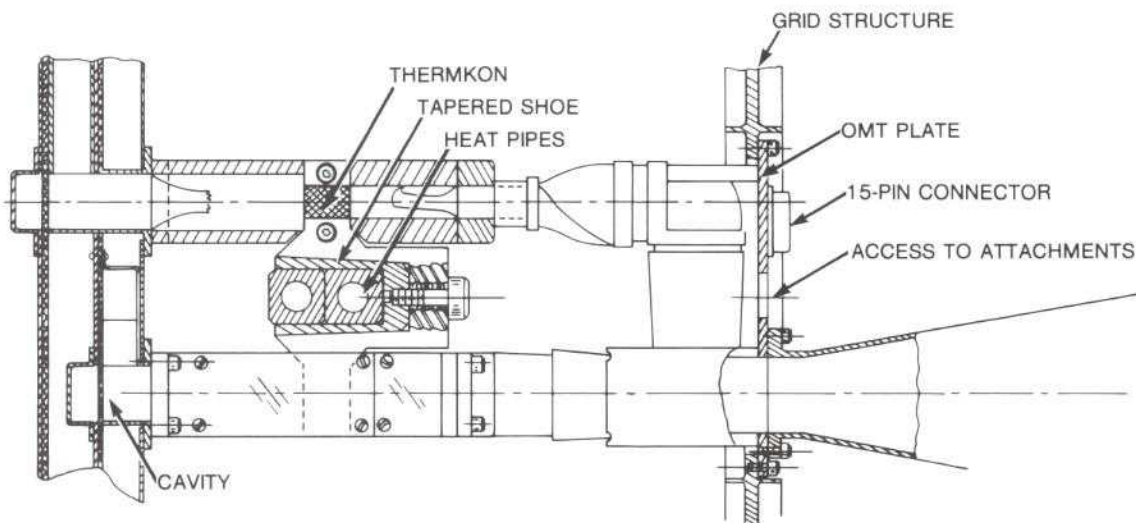

Figure 2. Mechanical/thermal design provides thermal control and facilitates disassembly of array elements



cages for the typical momentum wheel environment. Variables in this study included lubricant properties, temperature, number of balls, cage geometry, cage guidance, and cage balance. The computer program ADORE (Advanced Dynamics of Rolling Elements) was used to simulate the dynamic performance of the various cage designs and operating conditions. The design selected for experimentation was an 11-ball cage with small pocket and cage-to-race clearances and a slight mass offset or imbalance. Five different cages were machined in preparation for the experimental evaluation in early 1986.

Non-Jurisdictional

Sealed H₂/NiO Battery Development

COMSAT Laboratories is cost-sharing a development program with the Department of Energy for the design and development of the H₂/NiO battery under contract with Sandia National Laboratories. The objectives are to design and develop an H₂/NiO battery which is cost competitive with an advanced lead-acid battery for deep discharge, 20-year-life terrestrial energy storage applications.

COMSAT Laboratories conceived a new design approach to meet these objectives and engaged Johnson Controls, Inc. (JCI) as subcontractor for the design and development activity, utilizing JCI's expertise in large-scale battery manufacturing. Under the contract, COMSAT and JCI jointly designed and developed a sealed, 100-Ah, 6-V H₂/NiO battery for deep discharge, terrestrial application with a life expectancy of 20 years. Studies show that this H₂/NiO system can become cost competitive with advanced lead-acid batteries.

COMSAT SUPPORT

Space Communications Division

MARITIME SERVICES SUPPORT

The STD provided a team of specialists to review progress on the INMARSAT second-generation satellite program, as well as to assess the lifetimes of the first generation satellites currently being employed in the system. The division also assisted in the review of INMARSAT IIA spot beam antenna proposals as well as alternatives suggested by COMSAT Laboratories.

COMSAT TECHNICAL SERVICES

The STD provided support to the COMSAT Technical Services/Satellite Business Systems program office in El Segundo, California, where a new satellite is being developed by the Hughes Aircraft Co. An independent evaluation of the proposed satellite deployment scheme for shuttle launches revealed design risks which could be deleterious to the success of the program. Satellite Business Systems conveyed those spacecraft design concerns to the Hughes program office. The STD also participated in the spacecraft system critical design review.

Communications Services Division

COMSAT GENERAL

INMARSAT II Traveling Wave Tube Monitoring

The second generation INMARSAT spacecraft has imposed challenging efficiency and linearity requirements upon the TWTs (which provide 26 W at C-band and 80 W at L-band) to be used as down-link transmitters. A saturation efficiency of over 50 percent is required, and this has already been achieved at C-band by the manufacturer, Hughes Electron Dynamics Division. Particularly critical is the L-band TWT, which is to be operated in a unique four-TWT configuration which demands particular stability and reliability.

The STD monitors TWT developments and conducts independent evaluations of test data to obtain superior TWTs for INMARSAT. In addition, monitoring the manufacturing process ensures the highest technical performance of the TWTs.

ITALSAT Dynamics Analysis

During 1984, a dynamics analysis was conducted to determine the stability and performance of the complex ITALSAT spacecraft. During 1985, follow-on work was performed for Selenia Spazio using the spacecraft dynamics simulation program developed for ITALSAT by COMSAT Laboratories in 1984. The spacecraft includes pointing control systems (PCSs) for two reflectors and a three-axis attitude control system (ACS). The novel ITALSAT design employs high-bandwidth, two-axis antenna pointing mechanisms and associated control electronics to point the large reflectors based on errors measured by integral RF sensors, thereby creating high potential for deleterious interactions between the PCS and the ACS.



Complex analytical models were developed for the ACS, PCS, and structural flexibility of the solar arrays and the reflector deployment mechanisms. Generic models of both momentum wheel and thruster modes of the ACS were also developed. Software modules programmed from these models were integrated with the Dynamic Interaction Simulation of Controls and Structure (DISCOS) computer program which executes on the VAX 11/780 computer. DISCOS was used as the central executive program for the software modules. Simulations include stationkeeping, mode transition, momentum unloading, attitude acquisition, wheel failure, and wheel redundancy.

Product Assurance

The STD provided support to COMSAT Technical Services for the ITALSAT spacecraft program. The division contributed to several significant product assurance program documents, including a product assurance plan, a parts control plan, a program authorized parts list, and a parts, materials, and processes requirements specification. Specific questions and information requests were answered relative to parts, reliability, and product assurance. A high-reliability parts engineering and testing facility in Portsmouth, U.K., was surveyed for use in the program.

German Direct Broadcast Satellite Reliability Analysis

Space segment reliability tradeoff analyses were performed for the Federal Republic of Germany Bundespost. Seven different combinations of transponder and satellite configurations were considered for use in the 12-GHz television satellite. Variables included number of operational channels, number of satellites, transponder redundancy, time between launches, and mission duration. Results were provided for both a perfect launch and a launch with 90-percent probability of success.

A number of computer programs were used for this work. Reliability models were generated for the various Markov-approach satellite transponder configurations and a FORTRAN reliability program calculated the probability of success for each of the seven configurations. A graphics program plotted these data against mission length.

SATELLITE TELEVISION CORPORATION

During 1985, the STD provided extensive engineering support to the COMSAT Technical Services

program office, which has direct technical monitoring responsibility for the Satellite Television Corporation satellite program at RCA. Personnel provided on-site support for tests of major subsystems, including structures, thermal control, power, TT&C, and attitude determination and control (ADCS) subsystems. The following sections highlight some significant contributions.

Power Systems

To aid in direct broadcast satellite (DBS) spacecraft power subsystem testing, the STD designed and RCA produced electronic solar array simulators for both the housekeeping and transponder power subsystems. These simulators produce realistic operating conditions for the spacecraft power subsystem. Power subsystem regulation, impedance, stability margin, and thermal dissipation can be accurately verified without the solar array. Comparison testing with an illuminated solar array has verified the accuracy and usefulness of these simulators, which are also used during the testing of other subsystems to provide realistic power subsystem interfaces (see Figure 3).

Product Assurance

During 1985, implementation support continued for the DBS contractual product assurance program and the solution of parts, reliability, and quality assurance issues. This support was provided at RCA and its subcontractor's facilities as well as at COMSAT Laboratories.

COMSAT Laboratories personnel participated in the Parts, Materials, and Processes Control Board, including the review of the program authorized parts list, the program authorized materials and processes list, and parts and materials specifications, and the resolution of problems relative to failures, application, and availability. Product assurance support was also provided to the program in the form of quality audits, manufacturing readiness and design reviews, reliability prediction and analysis procedures, documentation, and test monitoring.

DBS Flight Simulator

In order to train DBS satellite control center operators and to deal with on-orbit control anomalies, an ADCS simulator was developed for the Satellite Television Corporation. This equipment is similar in most respects to ADCS simulators developed for the INTELSAT V and VI programs discussed in the

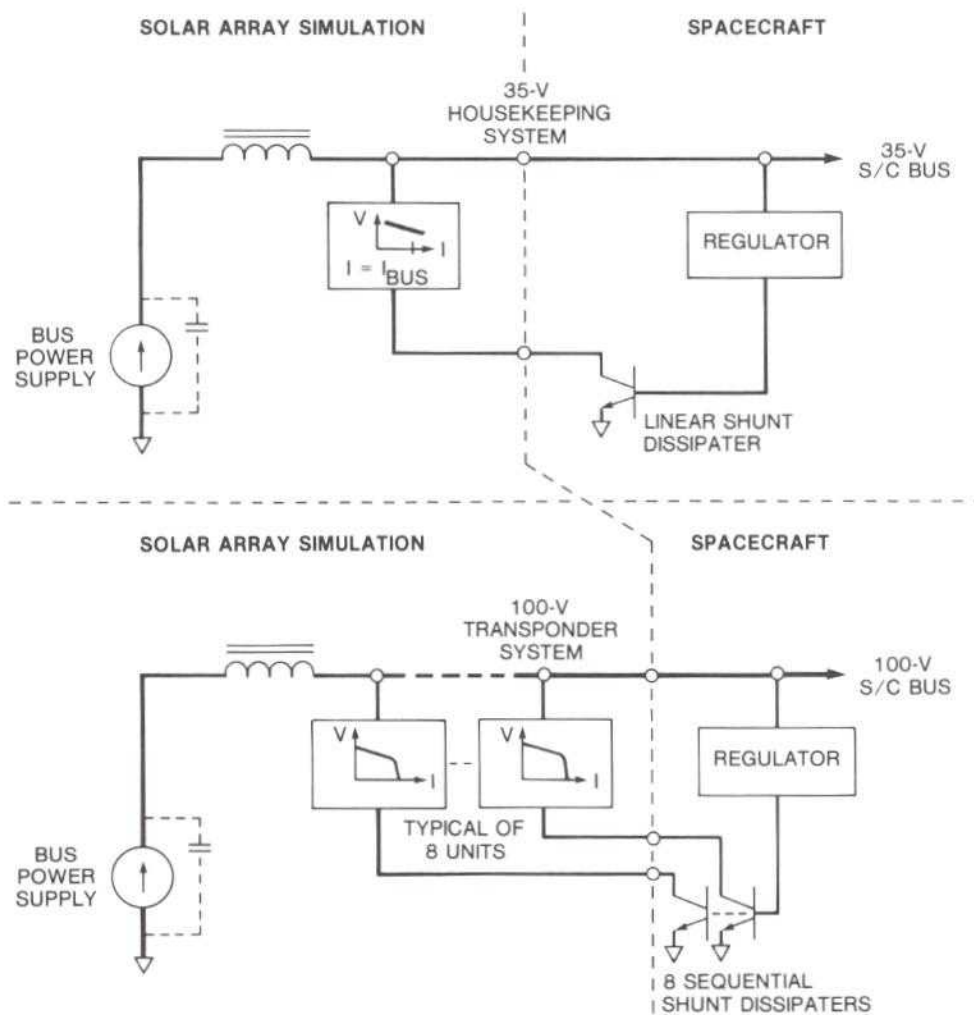

Figure 3. DBS solar array simulators produce realistic operating conditions for the spacecraft power subsystem

following subsections. The DBS flight simulator, pictured in Figure 4, includes a high-resolution video display which enables new operators to gain an understanding of the results of discrete commands more rapidly than has been possible in the past.

COMSAT INTERNATIONAL COMMUNICATIONS, INC.

Availability Analysis

Availability analyses were provided for various COMSAT International Communications, Inc. proposals for government and corporate earth stations and

satellite communications links. Figure 5 illustrates the total availability for one redundancy scheme. The work included furnishing mean-time-between-failure (MTBF) data for earth station and microwave link functions and estimates of mean time to restore (MTTR). Tradeoff studies included calculation of system availability vs MTTR.

COMSAT Technology Products

Product Assurance for Amplica

In accordance with applicable contract requirements, reliability analyses were performed to support

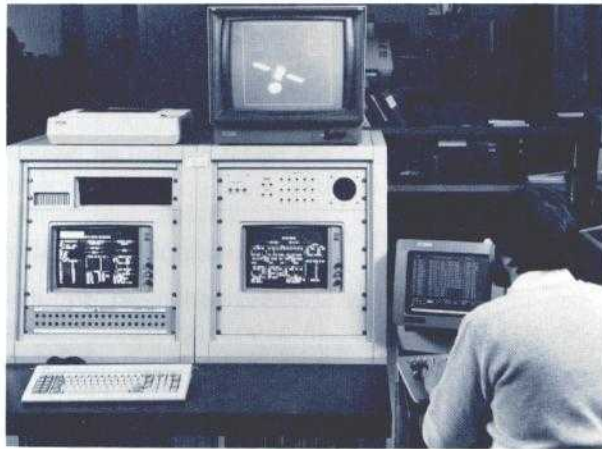

Figure 4. DBS flight simulator featuring high-resolution video display

Amplica equipment design and manufacture for military aircraft programs. The division also provided inspection and quality control of items being fabricated at COMSAT Laboratories for Amplica.

1.8-m Antenna Support for the Network Products Division

In response to a request from COMSAT Technology Products, Inc., the STD investigated the structural adequacy of the STARCOM antenna, a 1.8-m transmit and receive antenna system developed under a joint venture between COMSAT Technology Products and Reynolds Metal Company.

One evaluation unit and two production quality units were provided for RF and structural qualification. The RF performance was found to be excellent when tested on the rooftop range facility under low wind conditions. However, at moderate wind speeds of 25 to 35 mph, the system became dynamically unstable, with significant relative motion between the antenna primary components. Under these conditions, unacceptable motion occurred between the feed support structure and the antenna, along with excessive deflection of the primary support tube. The system had to be stiff enough to sustain both steady-state and gusty wind loads.

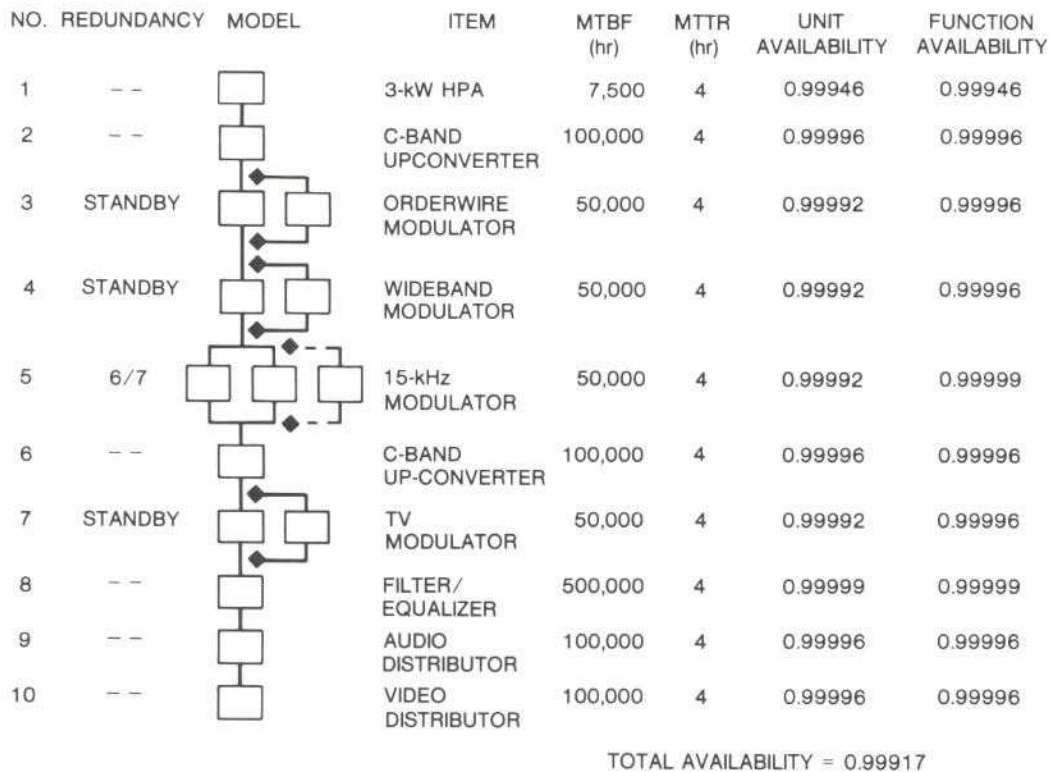

Figure 5. Availability analysis for standard B earth station shows system availability vs MTTR

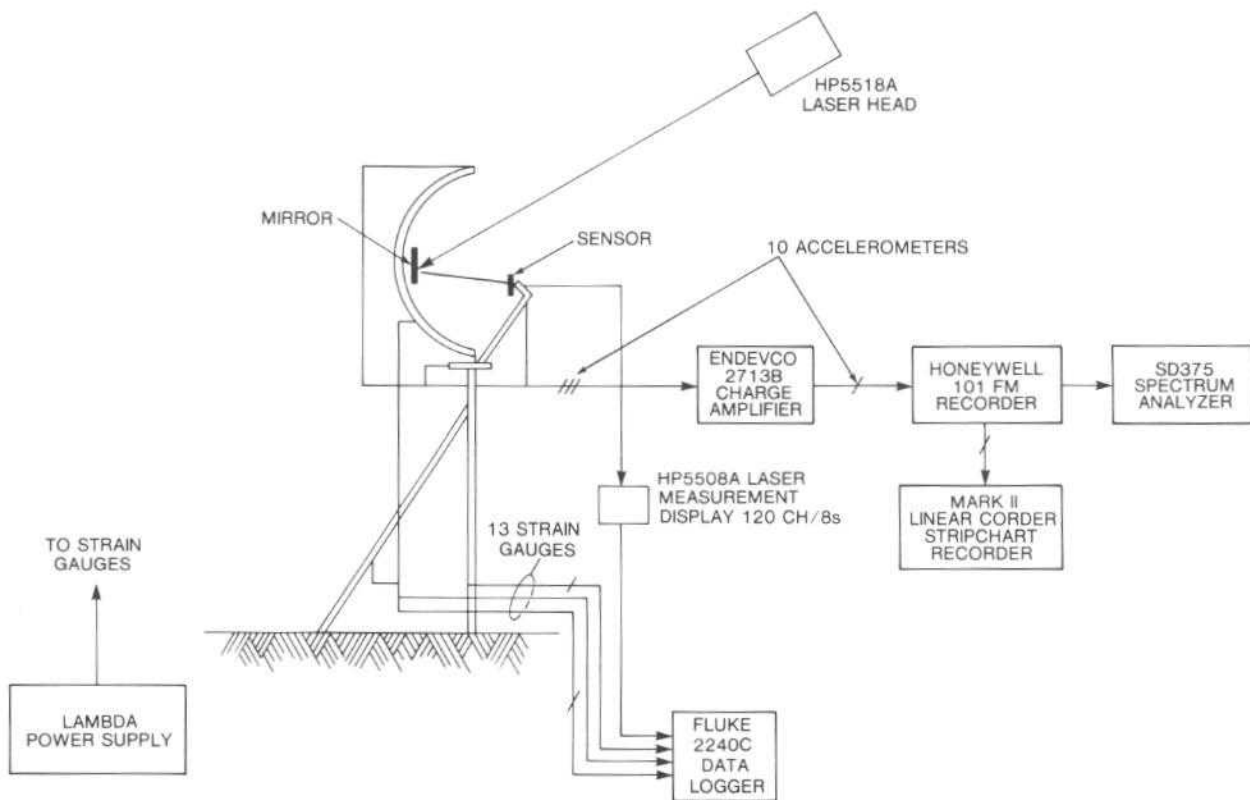

Figure 6. 1.8-m wind tunnel test setup tests performance of STARCOM antenna at 125-mph wind speeds

A NASTRAN computer model of the system was developed by the STD to verify the antenna's structural integrity. In addition, due to the dynamic instability resulting from a low-frequency torsional and bending resonance of the overall system, a modal frequency survey test was performed. As a result of this investigation, design modifications including additional struts and increased diameter of the primary support tube were recommended, significantly increasing the stiffness of the overall system.

In order to verify the compliance of the system to the pointing requirement and the survivability of the system at 125 mph, an in-depth wind tunnel test was planned at the University of Maryland's Glenn L. Martin Wind Tunnel Test Facility (see Figure 6). This test will determine antenna pointing accuracy, antenna system component vibration, and forces at the mounting base of the antenna system.

INTELSAT

INTELSAT V/V-A SUPPORT

TWT Leak Test Investigation

During 1984 it became clear that C-band TWTs for INTELSAT V-A spacecraft were prone to develop very slow vacuum leaks due to mechanical stress at the extreme of the test temperature range. Damage to the thermionic cathodes is slow but cumulative. The tube is capable of recovering from the effect of such small gas leaks accumulated during storage by being operated for some period of time, making positive identification of leaking tubes difficult and allowing a number of tubes to reach advanced stages of integration with the satellite before their deterioration had accelerated and became evident.



In the INTELSAT V-A TWTs tested, the outgassing rate of the potting material at the leak increases rapidly with temperature. The STD showed that after a baking procedure a number of tubes which had become suspect after many RF tests could be quickly classed as leaking when the noise sidebands were observed on a spectrum analyzer.

Battery Investigation

During 1985, the INTELSAT V/V-A battery investigation included continued life testing, anomaly investigation, and sample electrode analysis. The life-test batteries for INTELSAT V consist of a Ni/Cd and a Ni/H₂ battery, which are tested in real-time by simulating the electrical and thermal parameters of the in-orbit power subsystem. The Ni/Cd life-test battery has been tested for 13 eclipse seasons (6.5 years) and the Ni/H₂ battery for 9 eclipse seasons (4.5 years). These tests provide a baseline for performance data, an early look at the effects of wear, and an opportunity to test the operational constraints of the battery. As an example, when an anomaly was detected in one of the INTELSAT V F-7 satellite batteries, the life-test battery provided the opportunity to check the capabilities of the system to accommodate the weaker of the two on-board batteries. These test data contributed to the determination of spacecraft load limits which could be off-balanced between the two batteries while maintaining operation during eclipse.

Routine laboratory testing and destruct analysis are performed on sample electrodes (prior to cell manufacture) and on sample cells. Hence the performance, composition, and structure of energy storage devices and their components can be monitored, with deviation from specification noted.

INTELSAT VI

Solar Cell Testing

The STD continues to test solar cells representative of flight hardware for the INTELSAT VI spacecraft to evaluate cell operating characteristics in synchronous orbit. These data are being used as input to the division's solar array analysis computer programs which provide INTELSAT satellite operations with long-term and short-term predictions of INTELSAT VI solar array power once the spacecraft are launched.

Figure 7 shows the predicted INTELSAT VI solar array power generated using the division's solar array analysis computer programs. Once the spacecraft are

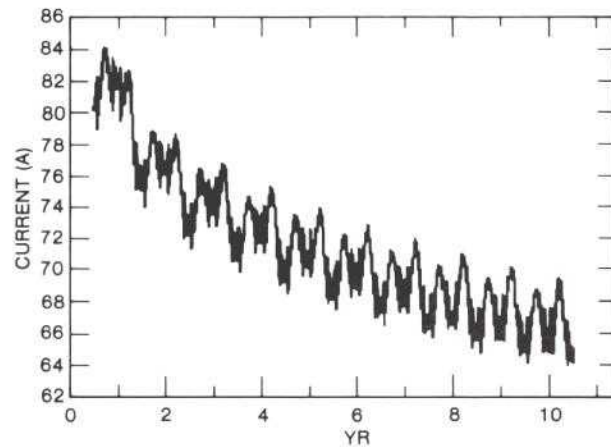

Figure 7. Solar array analysis programs predict INTELSAT VI solar array current at 29.3 V, June 21 launch

launched, similar predictions will be compared with actual performance so that INTELSAT will be able to optimize the allocation of communications traffic.

A long-term ultraviolet exposure test is continuing on a number of INTELSAT VI solar cells to determine the extent of solar cell degradation due to ultraviolet exposure. Figure 8 is a sample plot of percent degradation in short-circuit current vs ultraviolet exposure time for a group of INTELSAT VI Spectrolab K7 solar cells.

Ni/H₂ Battery Cells

Under the INTELSAT V support program, the STD worked with Ford Aerospace, Eagle Picher Industries, and INTELSAT to define objectives for a battery plaque improvement program, conduct the program, and review the results. The structure of the nickel plaque into which the active material is deposited is critical to the performance of the positive nickel electrode used in the nickel-hydrogen (Ni/H₂) battery cell. Therefore, a program was initiated to evaluate plaque materials fabricated by various processes and formulations. Eight different types of sample plaques, including those used on INTELSAT V and INTELSAT V-A, were characterized under Phase I of this program.

Plaque samples selected in Phase I were impregnated by both the aqueous and alcohol processes. These electrodes are presently being evaluated under Phase II of the program.

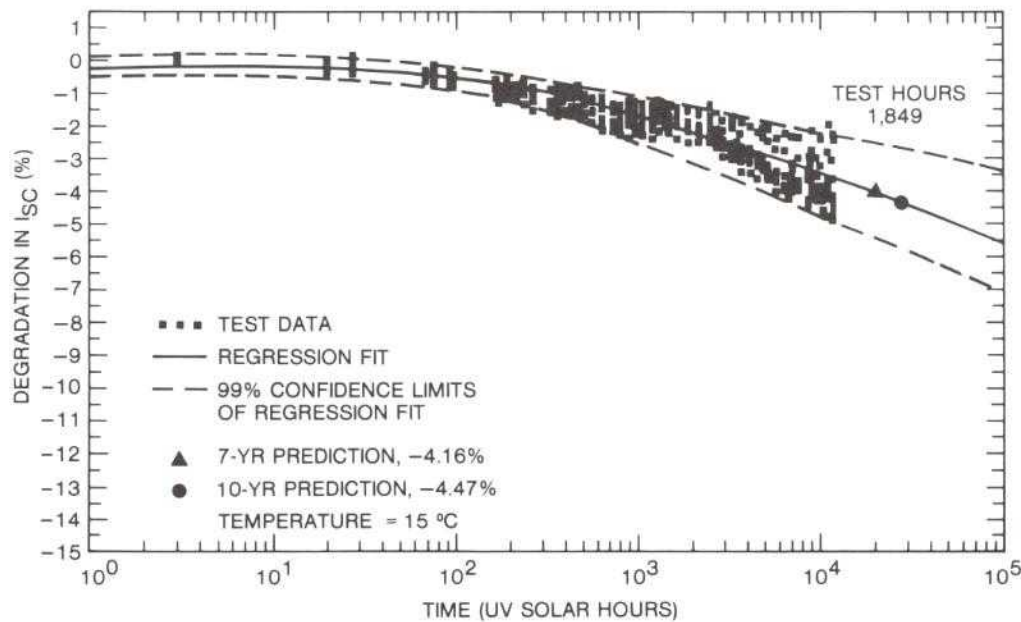

Figure 8. Ultraviolet exposure test determines solar cell degradation for all K7 cells

Deployable Mechanism Test Program

In order to achieve the on-orbit configuration of the INTELSAT VI satellite, the 4-GHz transmit antenna must undergo a two-stage deployment. First, the dish is deployed 223.7° , and then the boom is deployed 119.7° . The transmit boom deployment actuator is required to handle a large inertia load during deployment and to produce dynamic stability after deployment to its latched up position. The transmit boom actuator was subjected to both acceptance and qualification tests by Hughes Aircraft Company, the INTELSAT VI prime contractor. However, certain tests that are critical in terms of the satellite on-orbit operation were not done at Hughes. These tests, which were carried out by the STD, include small angle stiffness, structural response, reaction forces and torque, resonant frequency survey, and performance with offloader error tests.

A test program devised to evaluate the performance of an in-house flight unit of the actuator assesses whether the actuator would meet its design objectives and the requirements of the specialized tests. This evaluation includes procedures conducted during qualification and acceptance testing of the actuator. Figure 9 shows the actuator support structure and test fixture constructed for this program, including an

inertia simulator that produces one-tenth of the inertia of the actual boom assembly.

Product Assurance

During 1985, continued support was provided to the INTELSAT VI program to implement a suitable product assurance program and resolve parts and reliability problems. Primary effort was directed toward the selection, application, and evaluation of electronic parts and their procurement, testing, and use. This included participation in decisions regarding disposition of parts presenting a reliability risk due to manufacturing problems or failures of equipment. Product assurance processes and procedures at Hughes and its domestic and foreign subcontractors were also reviewed and recommendations made for improvements in reliability and quality.

INTELSAT SATELLITE OPERATIONS

Attitude Determination and Control System Simulator

The STD delivered the INTELSAT V ADCS flight simulator to INTELSAT Headquarters in 1985 and continued the design, development, fabrication, and

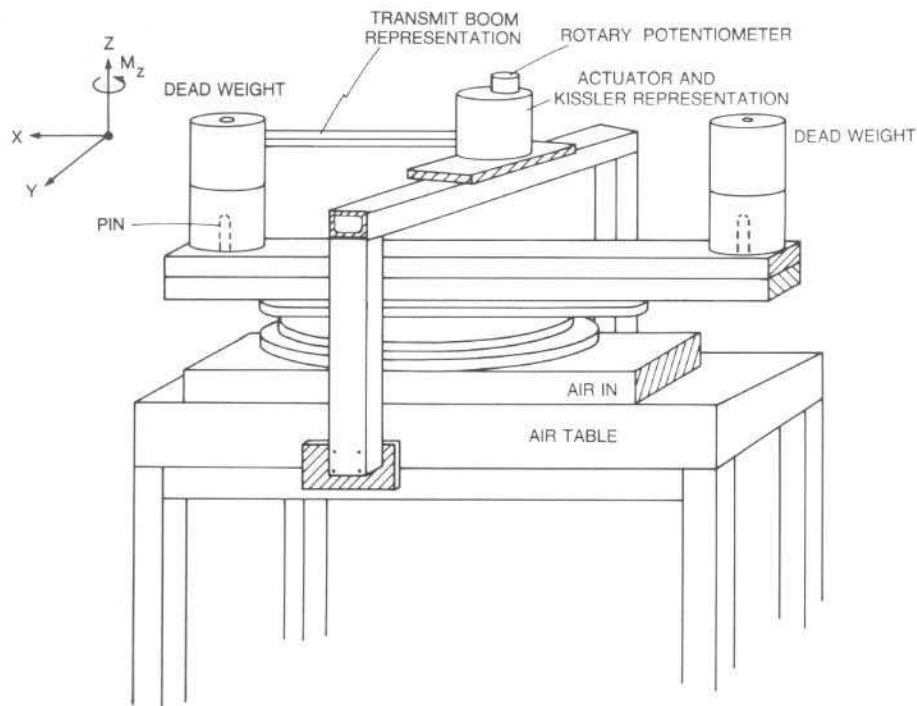

Figure 9. Inertia simulator fixture produces one-tenth of the inertia experienced by the transmit boom assembly

integration of the INTELSAT VI ADCS flight simulator as well as the DBS ADCS flight simulator. These devices allow operators to gain familiarity with routine maneuver sequences and engineers to develop contingency plans for dealing with on-orbit anomalies. In addition, they provide a test facility in which spacecraft operational procedures may be evaluated, practiced, or optimized. These simulators are designed to be used with external facilities such as tracking and command (T&C) data processing equipment or expert systems.

Each of these simulators operates in real time and incorporates engineering models of attitude control hardware. Their design allows the hardware to be exercised as if it were actually being used on the spacecraft. The rotational dynamics, structural flexibility, attitude sensors, actuators, and disturbance and environmental torques are implemented entirely on a 32-bit minicomputer using FORTRAN and assembly language. The simulators accommodate all mission phases except the spinning phase of the body-stabilized INTELSAT V and DBS designs. All redundancy is modeled, as well as a large number of fail-

ures which can be dynamically inserted and reset at any time during a simulation run.

The simulator operator can send commands to the simulated ACS; telemetry from the simulated ACS is displayed on cathode ray tube (CRT) monitors and stripchart recorders in the same format as at the T&C control center. In addition, a color graphics display of the spacecraft shows its attitude.

After being used for 4 years at COMSAT Laboratories, the INTELSAT V simulator was delivered, installed, and recommissioned at INTELSAT Headquarters. In 1985, it was used extensively for training engineers of the Satellite Evaluation and Control Section of INTELSAT. Both the INTELSAT VI and DBS simulator projects will be completed in the first half of 1986 after integration, validation, and acceptance test.

Solar Array Output Predictions

Solar cells of the type used on the INTELSAT VI spacecraft were tested at COMSAT Laboratories to determine their operating characteristics in space. Data from those tests are now being used as input to the COMSAT Laboratories solar array analysis com-

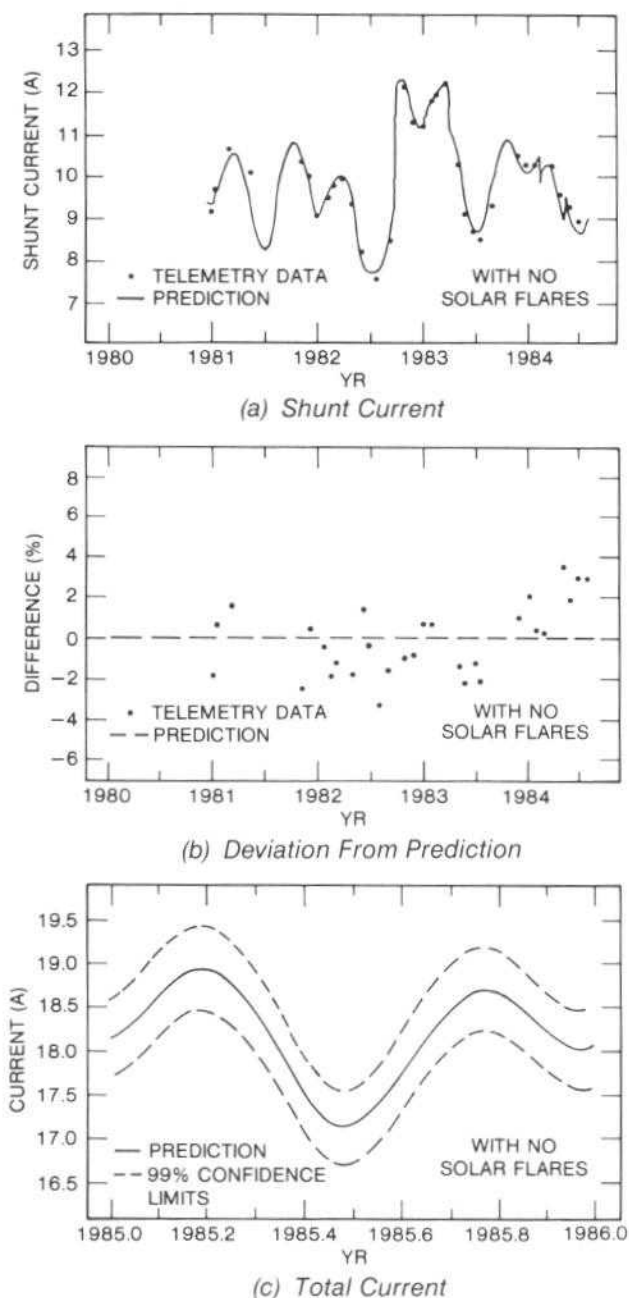

Figure 10. INTELSAT V F-2 solar array prediction used to optimize allocation of communications traffic

puter programs to provide solar array power predictions to INTELSAT. With the increasing competitiveness of the communications business, accurate predictions of available spacecraft power are vital for optimizing allocation of communications traffic.

Accurate predictions such as these can be achieved only by continually comparing predictions with actual performance and adjusting the model as needed. Figure 10 is an example of a solar array power prediction for the INTELSAT V F-2 spacecraft.

INTELSAT R&D

Analysis of Launch Loads

The STD has analyzed each of the INTELSAT V launch telemetry tape recordings to determine spacecraft bending loads and lateral accelerations, as well as accelerations at the launch vehicle interface. During 1985, the division statistically analyzed these flight data and compiled a data base of INTELSAT V launch loads for comparison with those predicted by the launch vehicle/spacecraft coupled loads analysis. This comparison is important in that it has identified discrepancies resulting from poor assumptions which may affect future satellite programs.

High-Vacuum Feedthrough

The incidence of breakdowns in INTELSAT V K_u -band TWTs led to occasional spurious shut-offs of the TWTAs in test and in orbit. Under Contract INTEL-327, COMSAT Laboratories studied factors which affect the resistance of a certain type of high-voltage vacuum feedthrough insulator to voltage breakdown.

Ceramic insulators of the type shown in Figure 11 were subjected to carefully chosen combinations of operating conditions in high vacuum:

- two different operating voltage levels
- exposure and nonexposure to evaporated materials such as barium from a thermionic cathode
- differing degrees of preoperation voltage conditioning
- differing degrees of high temperature bake-out processing.

Groups of four feedthroughs were continuously monitored with a high-speed waveform storage oscilloscope, usually for 30 days. Figure 12 shows typical current waveforms at breakdown. It was concluded that only the degree of preoperation voltage conditioning had an observable effect on the rate of breakdown occurrence, an important observation for guiding TWT processing in future programs.



Figure 11. Ceramic insulators typical of those tested to determine resistance to voltage breakdown

Ni/H₂ Battery Cell Test and Evaluation

This Ni/H₂ battery cell test and evaluation effort is an ongoing R&D activity that started in 1980. The major objectives are to evaluate new design concepts and new electrode stack components in order to advance the state of the art of the INTELSAT/COMSAT individual pressure vessel Ni/H₂ battery technology. In addition, the test program simulates two eclipse seasons per year in real time, with daily cycling between eclipse seasons simulating battery-powered electric propulsion. Fourteen cells are presently on test; the group 1 cells have completed 10 eclipse seasons, 5 years on test, or approximately 3,000 cycles.

Cell S/N 6 (one of the group 1 cells) with the Zircar separator material is showing a loss in capacity for each of the last two eclipse seasons. The other four cells in group 1 have the standard asbestos separator material and are quite stable. The average end-of-discharge voltage for these four cells has not changed

after 10 eclipse seasons. The major objective for 1986 will be to introduce a new synthetic separator material to replace the asbestos separator material.

OTHER

The STD maintains management responsibility for the Environmental Test Laboratory. Vibration, shock, temperature cycling, and thermal vacuum test services have been provided under contract to several outside customers for both ground and aerospace equipment. During 1985, these customers have included COMSAT Technology Products, Weinschel Engineering, and Schonstedt Instrument Co.

TWTA Tests for Hughes

The STD performed thermal cycling tests of DBS TWTAs for the Hughes Electron Dynamics Division during 1985 to determine whether changes in the TWT and TWTA operating characteristics would occur due to the eclipse cycling in spacecraft in geostationary orbit. To provide an accelerated simulation of these conditions, a flight-qualified TWTA was subjected to over 660 switched on/off cycles while in a thermal-vacuum environment similar to that expected in a spacecraft. Automated so that it requires no operators, the test continued for 4 months during which no significant variations were revealed in the continuously recorded input and output parameters. Safety features were incorporated to preclude test specimen damage in the event of power failure or malfunction.

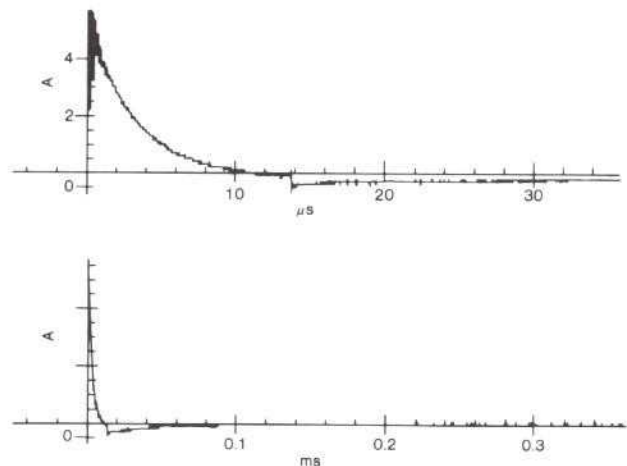

Figure 12. Typical current waveforms at breakdown provide guidance for TWT processing

SYSTEM DEVELOPMENT DIVISION

INTRODUCTION

The System Development Division (SDD) is responsible for system design and development activities in support of the several COMSAT lines of business, INTELSAT, and other COMSAT clients. The activities of SDD encompass the development of computer-based systems including the design and implementation of software and the selection, acquisition, installation and integration of hardware. Other SDD projects involve development of digital hardware and micro-process firmware for prototype equipment produced by COMSAT Laboratories; development of analysis and simulation techniques and computer software for evaluation and optimization of satellite communications systems and subsystems; exploration of new computer hardware and software technologies and their application to distributed processing systems; systems analysis and simulation; and establishment of standards, methodologies, and tools needed for development of highly reliable, easily maintained software products.

COMSAT R&D

Jurisdictional

COMSAT International Communications, Inc.

Intermodulation Analysis Tool Development

The COMSAT Intermodulation Analyzer (CIA) is an analysis tool used to determine RF intermodulation products that occur in a multicarrier transponder as a result of nonlinear phase and amplitude characteristics of the traveling wave tube amplifier (TWTA). It is used by systems engineers to predict baseband distortion in multichannel frequency-modulated/frequency-division multiple-access (FM/FDMA) signals transmitted through a common satellite transponder.

During 1985 an interactive version of CIA was designed for use on an IBM personal computer. This version of the program will allow the user to specify

the frequency plan through the use of menus and graphics. The program is expected to be completed and tested during 1986.

Space Communications Division

Transmission Impairments Analysis Tools

The Satellite Transmission Impairments Program (STRIP) is a powerful analysis program used to evaluate and optimize satellite frequency plans employing multiple frequency reuse. It is capable of calculating impairments in FDM/FM signals due to intermodulation, co-channel interference, and thermal noise. In the optimization mode, STRIP will automatically adjust each earth station's e.i.r.p. to minimize the worst-case transmission impairments.

STRIP uses an analytical model to compute baseband distortion based on the transfer characteristics of the nonlinear amplifiers, antenna gain patterns, and carrier parameters such as number of channels, IF bandwidth, rms signal deviation, and geographic location of earth stations. In each satellite transponder, all significant intermodulation products are identified, and the resulting baseband impairments are evaluated. Interference from co-channel time-division multiple-access (TDMA) transponders may also be computed.

With the planned introduction of new modulation techniques in the INTELSAT system to support new business services and with the operation of some of these carriers in the K_U -band or cross-strapped transponders, it was necessary to enhance the capabilities of STRIP to accommodate a mixture of different carrier types. SDD, together with the Communications Techniques Division, implemented models for several new carrier types, along with analysis algorithms, to determine signal impairments. An algorithm which optimizes the carrier power levels for all carrier types was also implemented.

New Antenna Coverage Program

The Antenna Coverage Program (ACP), developed in 1965, plots satellite antenna beam patterns that are superimposed on the earth's surface, as viewed from an arbitrary location. The most recent version of ACP, developed in 1985, has several new capabilities, including the ability to plot multiple-feed shaped beams or user-defined contours. Both equirectangular maps, such as that shown in Figure 1, and orthographic

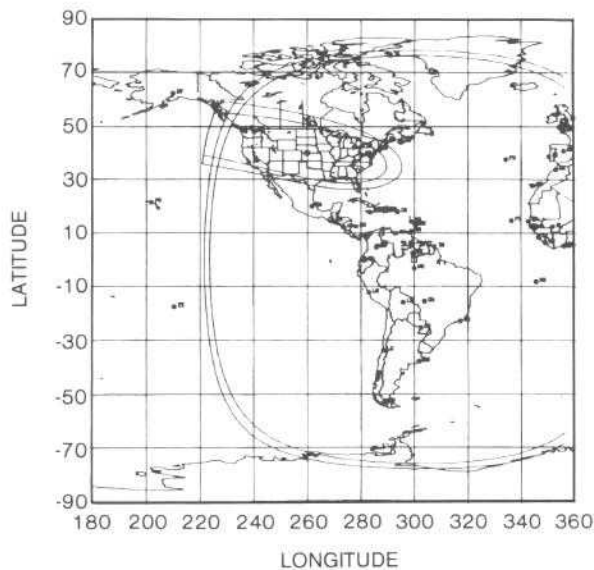

Figure 1. The new version of the Antenna Coverage Program can be used to plot an equirectangular map using the display option and gridlines

maps can be plotted. The program has been completely restructured to conform to currently accepted software standards and the analysis algorithms have been documented. The new version of ACP runs on an IBM personal computer.

COMSAT SUPPORT

COMSAT Technology Products, Inc.

Western Union Monitor and Control System

Western Union is establishing a privately operated satellite communications TDMA network. When fully configured, it will include 40 traffic terminals and 2 reference terminals. COMSAT TeleSystems, Inc. (TSI) is responsible for supplying the TDMA component of the Western Union system, using its DST-1000 traffic terminal.

The Western Union Monitor and Control (M&C) system, shown in Figure 2, is a facility allowing an operator to monitor and control an entire TDMA network. Such a network typically consists of two reference terminals and a number of traffic terminals. The M&C system executes in a PDP 11/24 microcomputer. It receives status data from all processors within each

terminal. This status is made available to the operator in summary and in detail form. The M&C system is also responsible for the definition of new terminals and for the addition and removal of terminals from the network. Finally, board-level diagnostics can be run on any terminal and the results reviewed. The Western Union M&C system was completed and integrated with the DST-1100 terminal during 1985.

DFS Monitor and Control System

The Deutsches Fernmeld Satelliten (DFS) M&C system will allow an operator to monitor and control a TDMA network which will serve West Germany. It will consist of 2 reference terminals and up to 100 traffic terminals. The M&C system consists of two processors: a network control processor (NCP) based on a VAX 11/730 and a front-end processor (FEP) based on a PDP 11/24. The NCP provides monitor and control functions similar to those in the Western Union M&C system. Beyond that, it provides a DECnet interface with the central operation and maintenance facilities where reservations are booked and billing is performed. The NCP also performs reservations processing and burst time plan computation. The FEP acts as a gateway to the TDMA network.

Development of the DFS M&C system was initiated in 1984 for TSI, and a version to support the Phase I TDMA network (i.e., without reservations and demand assignment) was completed in 1985. Additional enhancements of the M&C system and integration with the TDMA equipment are scheduled for 1986.

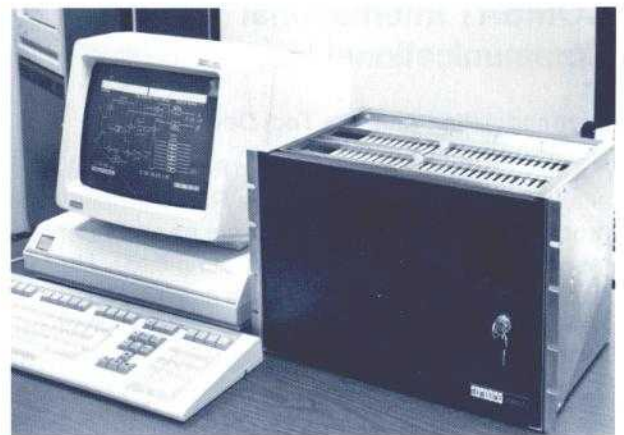

Figure 2. The Western Union Monitor and Control System allows an operator to monitor and control an entire TDMA network



Rate 7/8 FEC Codecs

A rate 7/8 forward error correction (FEC) coder/decoder (codec) was developed by SDD for installation in the TSI DST-1000 TDMA terminal. The codec employs a modified version of the double error correcting (1127, 113) Bose-Chaudhuri-Hocquenghem (BCH) code. The modification consists of the addition of one overall parity check bit and one dummy parity bit, and deletion of one data bit. The resulting (128, 112) modified BCH code provides for correction of all single and double bit errors and detection of all triple bit errors.

Relative to the theoretical uncoded bit error rate (BER) performance of an absolute encoded quadrature phase-shift keying (QPSK) modem, the codec typically provides coding gains of 1.9 and 2.6 dB at output error rates of 10^{-4} and 10^{-6} , respectively.

Quality Assurance and Configuration Management Services

SDD provided the Network Products Division (NPD) with consulting services relating to quality assurance and configuration management. The chief effort was to provide a new discrepancy reporting system which is more general and flexible than the system it replaced. This system has been successfully used on other major software.

STARCOM Operator Interface Design

A design for the STARCOM operator interface, developed for the NPD, takes advantage of the division's experience in this area. It is compatible with COSMOS, a real-time operating system developed within the Network Technology Division for high-speed computer networking applications. It supports multiscreen applications, graphics, and color on a DEC VT 240 terminal.

COMPACT

Gerber Photo Plotter Software

The GPLOT Program development, which was initiated in 1984, was completed in 1985. This program generates commands to photo-plot microwave circuit mask layouts on various models of Gerber Photoplotters. GPLOT uses as input the descriptions of the circuits generated by the AUTOART program. Operating on an IBM 370 computer or a VAX 11/780 computer, GPLOT is being marketed by COMPACT Software

and has been installed at Lincoln Laboratories and Sandia Laboratories.

INTELSAT

Support

TDMA Network Integration

The SDD is under contract to INTELSAT to provide support services during the network integration phase of the TDMA program. This contract encompasses several enhancements to the INTELSAT Operations Center TDMA Facility (IOCTF) (described in a subsequent section) which will accommodate new requirements resulting from operational experience with the TDMA system.

Tasks which are either complete or are in progress include:

- support during relocation of the IOCTF to the new INTELSAT headquarters
- implementation of an improved method of distributing satellite position coefficients to the TDMA reference stations
- the ability to transmit test condensed time plans to TDMA traffic terminals during pre-operational testing
- provisions for logging, retrieval, and display at the IOCTF of message traffic from TDMA reference and monitoring station (TRMS) sites.

Enhanced Transmission Impairments Analysis Capabilities

The INTELSAT Transmission Planning software was rewritten in 1985 to include models for analyzing and optimizing the performance of the new carrier types now planned or in place in the INTELSAT system. The carrier types include digital carriers, television carriers, companded single-sideband (CSSB) carriers, and models for bands of digital and single-channel-per-carrier (SCPC) carriers. An interface to read from the current INTELSAT transponder, antenna, and standard carrier data bases was also implemented in this software.

Bit Error Rate Analysis Software

The Bit Error Rate/Error-Free Seconds (BEEFS) program calculates estimates of bit error rate and



percent error-free seconds (EFS) for INTELSAT TDMA links including the effects of rain-induced impairments. The program was extended in 1985 to include the effects of interference from FDMA transponders into the TDMA links. In addition, a new user interface was implemented in the program.

Burst Scheduling Software Enhancements

The burst time plan (BTP) is a schedule that describes the allocation of communications channels in the fixed TDMA time frame. The BTP program generates burst time plans for the INTELSAT TDMA communications systems. SDD developed several major extensions to this program and its associated utility programs during 1985.

The associated utility programs generate the master time plans (MTPs) and condensed time plans (CTPs). The MTPs are operator-readable reports which contain all of a particular earth station's transmit and receive burst timing assignments, network acquisition and synchronization information, and baseband channel maps. They are sent to each administration before a new BTP is implemented. The CTPs, which are sent to the TDMA stations over the TDMA network, are machine-readable and contain a subset of the MTP which is loaded into each traffic or reference terminal.

During 1985, an error-checking system was designed and implemented in all of the programs in this system to detect inconsistencies or omissions in a BTP. The new system prints diagnostics and, in cases where a detected error will cause a TDMA system or station failure, does not allow the CTP to be generated for transmission to the network station.

Special Contracts

INTELSAT Operations Center TDMA Facility

During 1985, under Contract INTEL-213, SDD completed the delivery and installation of the IOCTF, a distributed minicomputer-based system which provides centralized monitoring and control of TDMA satellite communications networks. The division also assisted INTELSAT with using the IOCTF to perform pre-operational testing and subsequent operational support for the first two TDMA networks. The IOCTF provides around-the-clock support to TDMA operations by monitoring network alarms and status, distributing operational data for satellite position and TDMA BTPs, and controlling BTP changes and net-

work startup. In May of 1985, the IOCTF was moved from L'Enfant Plaza to the new Van Ness Headquarters where it is now in continuous service. A third operational TDMA Network will be added in 1986. Figure 3 shows the Operations Center TDMA Facility which is in operation at INTELSAT Headquarters in Washington, D.C.

TDMA System Monitor

Under Contract INTEL-196, SDD managed the delivery and installation of the INTELSAT TDMA System Monitor (TSM) equipment for the second and third TDMA networks during 1985. The TSM serves a vital function in the INTELSAT TDMA networks by independently measuring the critical characteristics of the TDMA bursts at radio frequencies. The TSMs provide alarms at the TDMA reference stations and at the IOCTF when the TDMA parameters being monitored exceed predefined limits.

Four TDMA reference and monitoring stations with TSMs were installed for the Indian Ocean Region TDMA network. Network tests were completed for the systems at Raisting, Germany; Yamaguchi, Japan; Fucino, Italy; and Djatiluhur, Indonesia. These systems are now in operational service. Two TSMs were installed at Tanum, Sweden, and Etam, West Virginia, for the second Atlantic Ocean Region network. Figure 4 shows a TSM which will participate in TDMA network tests early in 1986.



Figure 3. The INTELSAT Operations Center TDMA Facility provides centralized monitoring and control of TDMA satellite communications networks

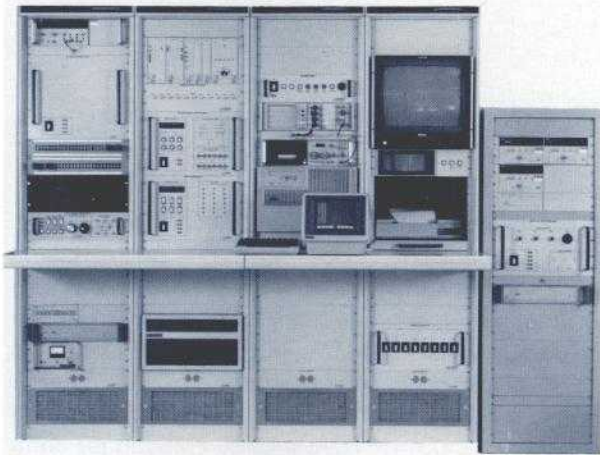

Figure 4. *The TDMA System Monitor measures critical characteristics of TDMA bursts at radio frequencies*

Traffic Terminal Simulator

The traffic terminal simulator (TTS) is a sophisticated, computer-based hardware tool that was developed under Contract INTEL-222 for in-plant verification of traffic terminals that are to operate in the INTELSAT TDMA networks. SDD developed a complete set of verification test procedures to run on the

TTS. These procedures, along with a test plan for their execution, were delivered to INTELSAT in March of 1985.

OTHER

GTE

TDMA Resource Allocation and Management Program

Under Contract GTE-ES.85.01, the TDMA Resource Allocation and Management Program (TRAMP) was designed by SDD in 1985 to generate TDMA BTPs for the GTE Spacenet TDMA systems. The program accepts as input a traffic matrix or multiplex plan. It then forms T1 and T2 sub-bursts and multiple-destination digital speech interpolation sub-bursts. The sub-bursts are grouped into traffic bursts and are assigned to specific earth station transmit and receive TDMA equipment. The bursts are then scheduled in appropriate time slots in their assigned transponders. Overhead bursts (such as reference, communications, and orderwire bursts) are formed and scheduled along with the traffic bursts. The program was developed on VAX 11/780 computer and installed at GTE Spacenet in McLean, Virginia.

ACTS PROGRAM

BACKGROUND

The extraordinary commercial success of satellite communications requires improved utilization of the limited available resources of the geostationary orbital arc. The National Aeronautics and Space Administration (NASA) has been the prime mover behind major breakthroughs in U.S. satellite communications technology and has undertaken a new research and development program, the Advanced Communications Technology Satellite (ACTS) Program, to develop basic technologies to ensure the availability of adequate and affordable satellite communications beyond the year 1990.

HISTORY

NASA's role in satellite communications was prominent throughout the mid-1960s and early 1970s. However, in 1974, following the successful deployment of the ATS-6, the NASA program in satellite communications technology was phased down considerably. The communications industry did respond and make impressive contributions to improve upon that technology. However, its ability to fund the expensive, long-term, high-risk breakthrough programs was limited (particularly in the case of those involving on-board technology).

The Executive Branch directed NASA to reassume responsibility for advanced satellite communications technology in 1978. With Congressional support and close coordination with American industry, the personnel of NASA's Lewis Research Center (LeRC) proceeded to plan a program for a multitechnology effort to exploit the advanced techniques now available for development. While the ACTS program selected the test bed of these techniques to be the K_a-band (30/20 GHz), the techniques are applicable to the other satellite bands of interest. After a period of analysis and trade-off evaluations, contracts for the procurement of the system, including both space and ground segments, were let in 1984 and COMSAT Laboratories was selected to culminate the extensive part it had played in the establishment of ACTS with a major role in the ground segment development program.

THE TECHNOLOGY NEEDS OF TOMORROW

A fundamental goal of NASA's reentry into satellite communications R&D is to ensure the continued availability of the orbital arc spectrum so vital to this communications technology. Ensuring the continued availability of the spectral resource requires a multifaceted effort: the development of communications techniques and equipment with which to exploit the spectrum-rich but largely unused K_a-band (which has twice the combined bandwidths of the C- and K_U-bands now being used commercially), plus the experimental investigation and verification of techniques which promise more effective use of all frequency spectrum resources allocated to satellite communications applications. The ACTS program objective is to achieve both goals by implementing its own baseline system effort, i.e., the ACTS flight segment and the NASA ground segment, as well as the experimenters' program it supports, at K_a-band.

The following component technologies comprise the baseline ACTS system:

- *Spot-Beam Technology*: Concentrating radio frequency energy into narrow beams, called spot beams, significantly enhances the ability to reuse these frequencies because the RF energy is being placed only where it is needed, and not spread over an entire continent. Further, the higher levels of power associated with spot beams can permit the deployment of lower cost terminal equipment. The use of both fixed and movable spot beams is an important extension of this technology.
- *On-Board Switching Technology*: This approach permits the interconnection of up-link spot beams with down-link spot beams in accordance with a subscriber's connectivity requirements and in coordination with an established time-division multiple-access (TDMA) timing plan.
- *On-Board Remodulation and Baseband Processing*: Such remodulation provides more effective amplification than analog repeaters as well as permitting mixed rate up-links and down-links for accommodating networks of both large and small terminals. The resultant intermediate baseband signal can then be processed and bundled by destination much in the same way as a terrestrial tandem switch.



- *Demand-Assigned (DA) TDMA Networking and Control:* The master control station (MCS) uses TDMA/DA algorithms to permit unique and effective coupling and control of the ground segment and the satellite resources. It provides cost-effective matching of the subscriber's transmission and connectivity requirements to the ACTS system performance envelope, as well as optimized allocation of the remaining satellite resources of power, spectrum, etc., to the remaining users.

The ACTS experimental flight system is designed to verify each of these critical technologies and to test their combined effectiveness in a communications satellite system, while providing a test bed with sufficient architectural and configuration flexibility to permit significant testing by the experimenter community.

THE ACTS EXPERIMENTAL COMMUNICATIONS SATELLITE SYSTEM

The ACTS Program team spent much of the past year in consolidating and refining its system-level configurations and specifications. This activity culminated with the approval of a System Design Review in July 1985, but several significant changes in the system design have been made since then. The system configuration described below is the most current one and is reflected in Figure 1.

The ACTS spacecraft features two types of spot-beam coverage, each spot beam covering an area about 150 miles wide. There are 16 fixed spot-beam regions available, each focused on a major U.S. city,

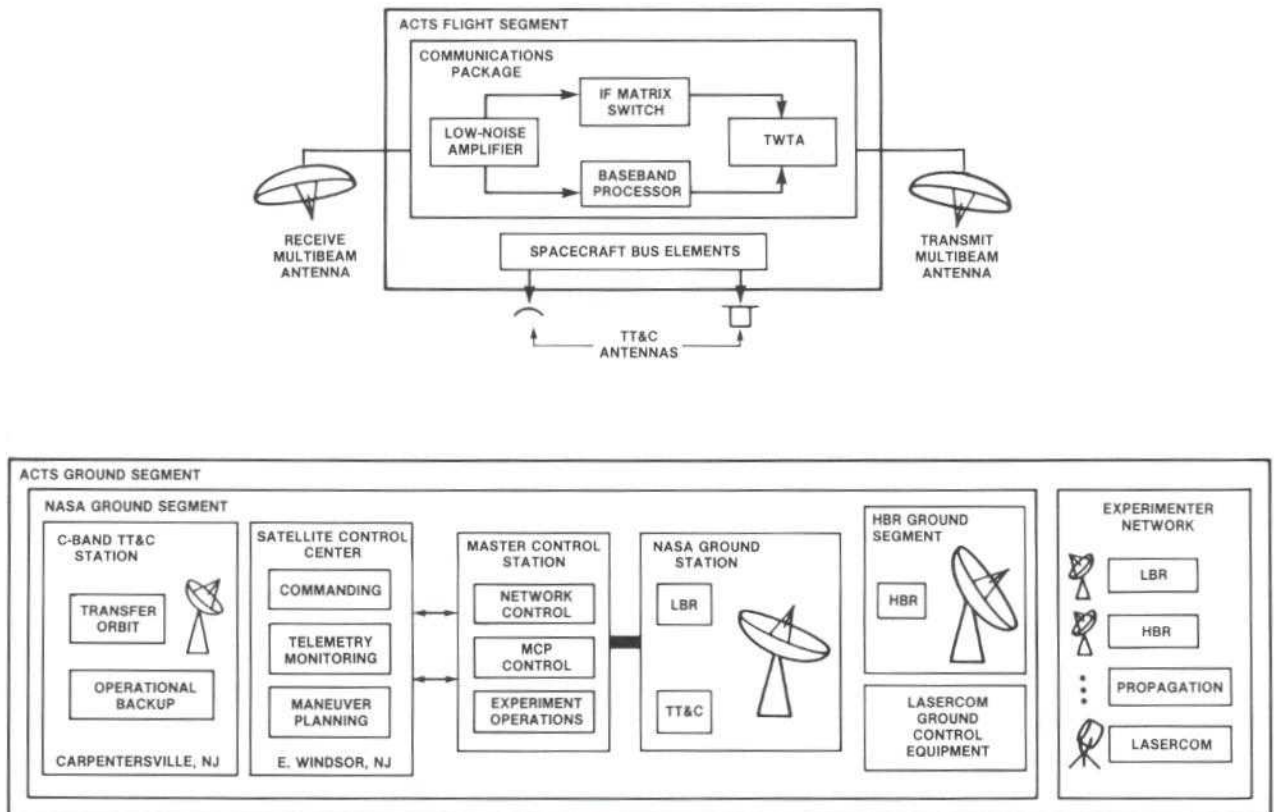

Figure 1. The current ACTS system configuration features both fixed and scanning spot-beam coverage



and there are two scan sectors (east and west) for high-speed selectable pointing ("scanning") of spot beams. This beam pointing is programmed from the MCS such that, over a 1-ms time frame, the transmit and receive beams "dwell" on a sequence of regions to both send and receive their transmissions; the length of the "dwell" is related to the required transmission capacity.

The up-link and down-link signals are classified as high burst rate (HBR) or low burst rate (LBR) and are carried in three very wideband "channels." The HBR signals, usually having 220-Msymbol/s burst rates, are routed through an intermediate frequency (IF) matrix switch which interconnects the up-link spot-beam signals to the down-link spot-beam signals. The LBR up-link signals, which have burst rates of either 27.5 or 110 Msymbol/s, are routed through the baseband processor, which performs demodulation, rate buffering, slot interchanging, error-control coding, and remodulation into the down-link, which has a 110-Msymbol/s burst rate.

The ACTS spacecraft bus is the responsibility of RCA ASTRO-Electronics, which is also the prime contractor for the ACTS Program. The on-board multibeam communications package is to be furnished by TRW, with the baseband processor supplied by Motorola. A novel feature of the ACTS Program is the incorporation of a laser-based communications experiment. This unit, known as LASERCOM, as well as its ground terminal, is to be supplied by MIT's Lincoln Laboratory.

Upon launch, the ACTS spacecraft will be positioned at 100°W longitude using RCA telemetry, tracking and command (TT&C) facilities in New Jersey, which will also be responsible for the usual telemetry/command and stationkeeping functions. These facilities will maintain not only their usual direct connection to the spacecraft, but also will be interconnected to the MCS, which is then linked to the spacecraft via a NASA ground station.

THE ACTS GROUND SEGMENT

There are now five distinct elements to the ACTS ground segment:

- *The NASA Ground Station (NGS)*, shown in Figure 2, is to be developed by COMSAT. It consists of a single RF terminal (RFT) driven by two LBR terminals: the 27.5-Msymbol/s traffic terminal, with its terrestrial interface equipment for accommodating

terrestrial traffic interconnection; and a combined reference terminal and traffic terminal (110 Msymbol/s), with the reference terminal having the responsibility for maintaining TDMA system synchronization and integrity. Within the NGS is also included some RCA-provided TT&C equipment which interfaces with the RFT subsystem. The NGS will be located at NASA LeRC in Cleveland.

- *The Master Control Station*, also the responsibility of COMSAT, controls the LBR network and the on-board multibeam communications package, is the focal point for mission and experiment operations, and provides displays and reports required to maintain orderly system operation. Figure 3 shows the computer equipment of the MCS, which will be colocated with the NGS at the NASA LeRC.
- *The Telemetry, Tracking, and Command Facilities* are related largely to spacecraft support operations such as stationkeeping: the RCA facilities in Carpentersville and East Windsor, New Jersey, will perform this function. RCA will provide the TT&C elements to be located at the NGS.
- *The HBR Ground Segment* will function in a role similar to that of the LBR NGS. It is the responsibility of NASA and will be located in the vicinity of the NGS at LeRC.
- *The LASERCOM Ground Segment* is the responsibility of MIT's Lincoln Laboratory; its interfaces into the ACTS Ground Segment are still to be determined.

In addition to the ACTS ground segment, there will be an experimenters' network equipped for both LBR and HBR operation through the ACTS spacecraft, conducting experiments and coordinated into the ACTS system via the MCS.

ACHIEVEMENTS OF THE COMSAT ACTS TEAM

The COMSAT effort in the ACTS Program is directed by the COMSAT Laboratories ACTS Program Management Office (PMO). The technical support for the ACTS PMO is coordinated through a matrix-management arrangement with several divisions of the Laboratories. Major ACTS support is provided by the Microwave Technology, Network Technology, and System Development Divisions, together with elements of the Design and Fabrication Center. At the peak of the ACTS development program, nearly one-

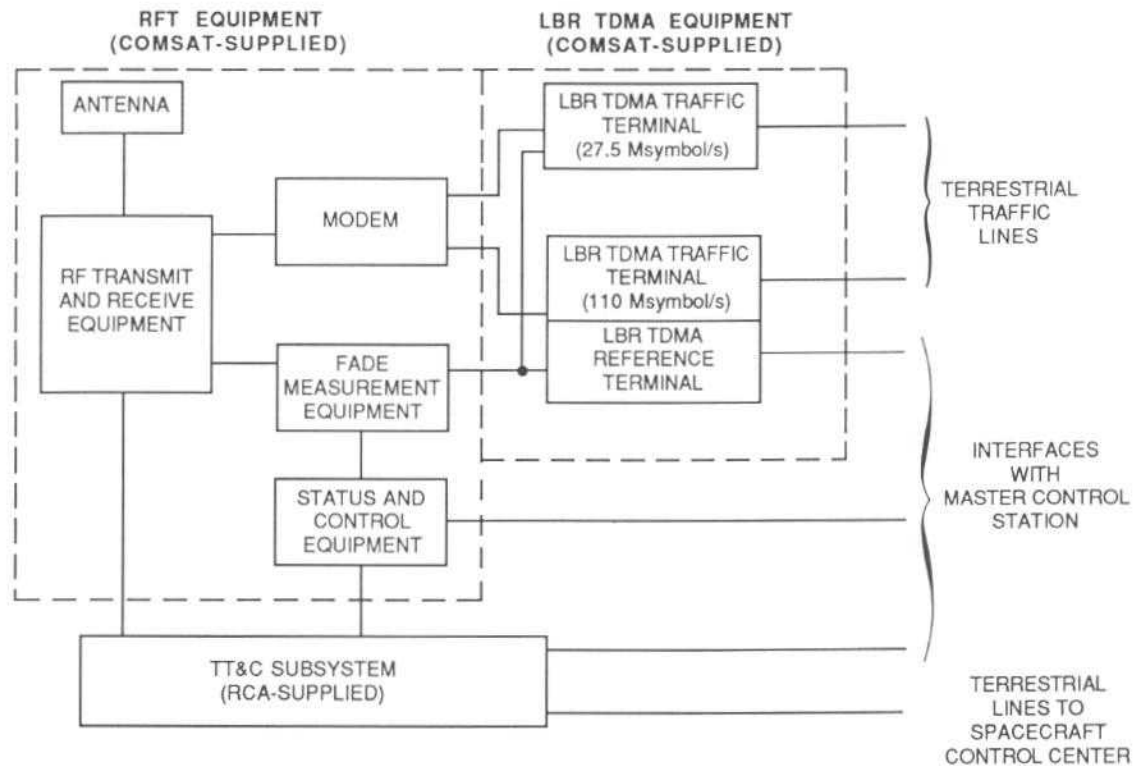

Figure 2. The NASA ground station consists of a single RF terminal driven by two LBR terminals

fourth of the Laboratories resources will support the ACTS program. During the past year, the COMSAT ACTS team has been actively participating as a major force in the system-level formulation of the overall ACTS architecture, as well as diligently pursuing its objectives in its own area of responsibility—the NGS/MCS. The system-level specifications of NGS/MCS function, performance, and interface have been completed, presented, and reviewed by NASA and the contractor teams at both the System Design Reviews and the Preliminary Design Reviews. Work is now progressing into the design levels, with the functional elements in terms of hardware/software being described and with long-lead-time components being ordered.

ACTS System Engineering activities have focused on the modeling of the modulation channel and the simulation of the networking, in addition to the documentation of the higher level specifications. Performance has been verified by comparing simulations using computer models with measured results. The

NGS/RFT group has concentrated on translating the system-level specification into subsystem specifications for the major RFT functional elements—antenna, transmitter, receiver, modems—plus the many associated elements, such as special test equipment, status and control units, and measurements. These specifications have now reached the design level. These elements of the design stage have been substantially completed and the procurement stage entered.

Similar efforts are proceeding in the ACTS TDMA Engineering team where the designs for the major functional elements (transmit burst controller, receive burst controller, and terrestrial interface equipment) are being developed. The ACTS MCS Engineering group has been concerned with the procurement and testing of the MCS central processing unit, as well as developing and specifying its major functional areas: MCP telemetry/control, LBR TDMA networking, and RFT interface support. Further, it supports several other areas, such as experiment configuration and



Figure 3. *The master control station is the focal point for mission and experiment operations*

data processing, and the MCS executive and utilities. The ACTS Performance Assurance team has focused on the establishment of procedures for configuration control of the hardware and software, component reliability analysis and specification, procurement and

production planning, and quality assurance audits. A vital role in the administration and management of the COMSAT ACTS Program is also played by the teams responsible for financial and schedule control.

1985 PUBLICATIONS AND PATENTS

PUBLICATIONS

The following is a list of 1985 publications by authors at COMSAT Laboratories. Reprints of these articles can be obtained from the authors at COMSAT Corporation, 22300 Comsat Drive, Clarksburg, Maryland 20871.

- Abita, J. L., "Technology: Development to Production," *IEEE Transactions on Engineering Management*, Vol. EM-32, No. 3, August 1985, pp. 129-131.
- Bargellini, P. L., "Satellite and Space Communications," *Reference Data for Engineers: Radio, Electronics, Computer, and Communications*, Chapter 27, 7th ed., E. C. Jordan, Editor, Indianapolis, IN: Howard W. Sams and Company, Inc., 1985.
- Barnett, J., and Phiel, J. F.,* "INTELSAT TDMA System Monitor," *International Journal of Satellite Communications*, Vol. 3, Nos. 1 and 2, January-June 1985, pp. 57-69.
- Benjamin, M. C., and Bogaert, W. M., "COMSAT's TDMA Traffic Terminal," *International Journal of Satellite Communications*, Vol. 3, Nos. 1 and 2, January-June 1985, pp. 15-25.
- Bonetti, R. R., and Williams, A. E., "High Power Multiplexer for DBS Earth Stations," European Microwave Conference, Paris, France, September 1985, *Proc.*, pp. 364-369.
- Cahana, D., Potukuchi, J. R., Marshalek, R. G., and Paul, D. K., "Linearized Transponder Technology for Satellite Communications, Part I: Linearizer Circuit Development and Experimental Characterization," *COMSAT Technical Review*, Vol. 15, No. 2A, Fall 1985, pp. 277-308 [CTR85/289].
- Chang, A. T. C.,* and Fang, D. J., "The Effect of Scintillation on the Active Microwave Remote-Sensing Sensors," *International Journal of Remote Sensing*, Vol. 6, No. 7, 1985, pp. 1231-1240.
- Effland, J., "An Automated Antenna Measurement System," International Symposium on Antennas and Propagation, Kyoto, Japan, August 20-22, 1985, Paper 034-1, *Proc.*, pp. 181-184.
- Ekelman, E. P., and Gilmore, S. W., "Retrofitting an Earth Station Antenna for Dual Polarization: Design Considerations," IEEE AP-S International Symposium on Antennas and Propagation, Vancouver, Canada, June 17-21, 1985, *Digest*, Vol. 1, pp. 323-326.
- Ezzeddine, A., Hung, H.-L. A., and Huang, H. C., "High-Voltage FET Amplifiers for Satellite and Phased-Array Applications," IEEE MTT-S International Microwave Symposium, St. Louis, MO, June 4-6, 1985, *Digest*, pp. 336-339.
- Fang, D. J., and Sandrin, W. A., "Study of Propagation Effects Applicable to L-Band Ship-Earth Stations," International Symposium on Antennas and Propagation, Kyoto, Japan, August 20-22, 1985, *Proc.*, Vol. 1, pp. 333-336.
- Fullett, K. D., and Riginos, V. E., "A Contour Generation Algorithm Applied to Antenna Patterns," *COMSAT Technical Review*, Vol. 15, No. 2A, Fall 1985, pp. 211-236 [CTR85/286].
- Geller, B. D., and Abita, J. L., "A 3.7- to 4.2-GHz Monolithic Medium Power Amplifier," *Microwave Journal*, Vol. 28, No. 9, September 1985, pp. 187-190, 193-195.
- Gruner, R. W., "Design Procedure for a Distributed Reactance Waveguide Polarizer," IEEE AP-S International Symposium on Antennas and Propagation, Vancouver, Canada, June 17-21, 1985, *Digest*, Vol. 2, pp. 635-638.
- Hodge, G., Johnson, R., Cook, W., and Saralkar, K., "INTELSAT Operations Center TDMA Facility," *International Journal of Satellite Communications*, Vol. 3, Nos. 1 and 2, January-June 1985, pp. 71-76.
- Holdeman, L. B., Barber, R. C., and Abita, J. L., "An Approach to Fabricating Sub-Half-Micrometer-Length Gates for GaAs Metal-Semiconductor Field-Effect Transistors," *Journal of Vacuum Science and Technology: B*, Vol. 3, No. 4, July/August 1985, pp. 956-958.
- Holdeman, L. B., and Holdeman, J. T., Jr.,* "Torque on a Spinning Superconducting Sphere Inside a Superconducting Cylinder or Spherical Cap," *Journal of Applied Physics*, Vol. 57, No. 3, February 1, 1985, pp. 684-697.
- Hung, H.-L., Enobakhare, E., Abita, J., McNally, P., Mahle, C., and Huang, H., "GaAs FET MMIC Low-Noise Amplifiers for Satellite Communications," *RCA Review*, Vol. 46, December 1985, pp. 431-440.
- Inukai, T., and Snyder, J. S., "Parallel Implementation of Linear Feedback Shift Register Circuits," *COMSAT Technical Review*, Vol. 15, No. 2A, Fall 1985, pp.343-351 [CTR85/290].

*Non-COMSAT author.



- James, P. K., "Simulation of Deployment Dynamics for INTELSAT VI Transmit and Receive Boom/Antenna Systems," *COMSAT Technical Review*, Vol. 15, No. 1, Spring 1985, pp. 127-148 [CTR85/283].
- Karimullah, K., and Egri, R. G., "A 4-GHz QPSK Modulator for High Bit Rates," *COMSAT Technical Review*, Vol. 15, No. 2A, Fall 1985, pp. 197-210 [CTR85/285].
- Kelly, W. H., and Reisenweber, J. H., "Experimental Measurement of Solar Absorptance of an INTELSAT VI OSR Radiator as a Function of Incidence Angle," *COMSAT Technical Review*, Vol. 15, No. 2A, Fall 1985, pp. 259-275 [CTR85/288].
- King, C., Trusty, P., Jankowski, J.,* Duesing, R.,* and Roach, P.,* "INTELSAT TDMA/DSI Burst Time Plan Development," *International Journal of Satellite Communications*, Vol. 3, Nos. 1 and 2, January-June 1985, pp. 35-43.
- Krichevsky, V., and DiFonzo, D. F., "Optimum Beam Scanning in Offset Single and Dual Reflector Antennas," *IEEE Transactions on Antennas and Propagation*, Vol. AP-33, No. 2, February 1985, pp. 179-188.
- Kumar, P. N., "Fade Duration Statistics from COMSTAR 20/30-GHz Beacon Measurement Program," *COMSAT Technical Review*, Vol. 15, No. 1, Spring 1985, pp. 71-87 [CTR85/280].
- Lee, S. H., and Rudduck, R. C., "Aperture Integration and GTD Techniques Used in the NEC Reflector Antenna Code," *IEEE Transactions on Antennas and Propagation*, Vol. AP-33, No. 2, February 1985, pp. 189-194.
- Lee, Y. S., Brelian, I., and Atia, A., "Linearized Transponder Technology for Satellite Communications, Part II: System Simulation and Performance Assessment," *COMSAT Technical Review*, Vol. 15, No. 2A, Fall 1985, pp. 309-341 [CTR85/289].
- Lunsford, J. A., and Dobyns, T. R., "A Reference Station Emulator for Testing INTELSAT TDMA/DSI Terminals," *COMSAT Technical Review*, Vol. 15, No. 2B, Fall 1985, pp. 511-525 [CTR85/296].
- Lyons, J. W., III, "In-Orbit Performance of INTELSAT Spacecraft Solar Arrays," 20th Intersociety Energy Conversion Engineering Conference, Miami Beach, FL, August 18-23, 1985, *Proc.*, Vol. 1, pp. 1.43-1.47.
- McNally, P. J., "Formation of High-Quality N-Layers in GaAs by Ion Implantation," *COMSAT Technical Review*, Vol. 15, No. 1, Spring 1985, pp. 113-125 [CTR85/282].
- Mahle, C., and Huang, H. C., "MMIC's in Communications," *IEEE Communications Magazine*, Vol. 23, No. 9, September 1985, pp. 8-16.
- Paul, D. K., "Communications via Undersea Cables: Present and Future," 29th Annual Society for Photo-Optical Instrumentation Engineers Meeting, San Diego, CA, August 18-23, 1985, *Proc.*, Vol. 559, pp. 36-50.
- Pontano, B., "The INTELSAT TDMA/DSI System: An Overview of the Special Issue," *International Journal of Satellite Communications*, Vol. 3, Nos. 1 and 2, January-June 1985, pp. 5-9.
- Pontano, B. A., Campanella, S. J., and Dicks, J. L., "The INTELSAT TDMA/DSI System," *COMSAT Technical Review*, Vol. 15, No. 2B, Fall 1985, pp. 369-398 [CTR85/291].
- Potukuchi, J. R., Geller, B. D., Mott, R. C., and Gupta, R. K., "Design and Development of Monolithic 6/4-GHz Transponder Subsystems," Government Microcircuit Applications Conference, Orlando, FL, November 5-7, 1985, *Digest*, pp. 353-354.
- Price, R., Stuart T., Effland, J., Sato, I.,* Tamagawa, I.,* Mori, I.,* and Iwata, R.,* "Dual Frequency Band Antenna for INTELSAT Earth Stations," International Symposium on Antennas and Propagation, Kyoto, Japan, August 20-22, 1985, Paper 232-2, *Proc.*, pp. 923-926.
- Rappaport, C.M.,* and Zaghloul, A. I., "Optimized Three-Dimensional Lenses for Wide-Angle Scanning," *IEEE Transactions on Antennas and Propagation*, Vol. AP-33, No. 11, November 1985, pp. 1227-1236.
- Ridings, R.P., Lindstrom, R.R., and Dobyns, T. R., "An Experimental TDMA Traffic Terminal," *COMSAT Technical Review*, Vol. 15, No. 2B, Fall 1985, pp. 399-422 [CTR85/292].
- Rieser, J. H., and Onufry, M., "Terrestrial Interface Architecture (DSI/DNI)," *COMSAT Technical Review*, Vol. 15, No. 2B, Fall 1985, pp. 483-509 [CTR85/295].
- Rogers, D. V., "Propagation Considerations for Satellite Broadcasting at Frequencies Above 10 GHz," *IEEE Journal on Selected Areas in Communications*, Vol. SAC-3, No. 1, January 1985, pp. 100-110.
- Rogers, D. V., and Allnutt, J. E.,* "Some Practical Considerations for Depolarization Compensation in 14/11- and 14/12-GHz Communications Satellite Systems," *Electronics Letters*, Vol. 21, No. 23, November 1985, pp. 1093-1094.

*Non-COMSAT author.



- Sandrin W., Chen, H., Hagmann, W., Mackenthun, K., and Rhodes, S., "Aeronautical Satellite Data Link Study, *COMSAT Technical Review*, Vol. 15, No. 1, Spring 1985, pp. 1-38 [CTR85/278].
- Siddiqi, S., Zaghoul, A. I., Chou, S. M., and Eaves, R. E., "An L-Band Active Array System for Global Coverage," *COMSAT Technical Review*, Vol. 15, No. 1, Spring 1985, pp. 1-38 [CTR85/279].
- Smith, T., "A Modeling System for Simulation of GaAs FET Performance," *COMSAT Technical Review*, Vol. 15, No. 2A, Fall 1985, pp. 237-258 [CTR85/287].
- Sorbello, R. M., and Lee, B.S., "A 12/17-GHz Transmit/Receive Feed Module for DBS Antenna Applications," *IEEE AP-S International Symposium on Antennas and Propagation*, Vancouver, Canada, June 17-21, 1985, *Digest*, Vol. 2, pp. 489-492.
- Stockel, J., "Self-Discharge Performance and Effects of Electrolyte Concentration on Capacity of Nickel-Hydrogen Cells," 20th Intersociety Energy Conversion Engineering Conference, Miami Beach, FL, August 18-23, 1985, *Proc.*, Vol. 1, pp. 1.171-1.174.
- Suyderhoud, H.G., "User Quality Assurance in Telephone Network System Parameters," *IEEE International Conference on Communications*, Chicago, IL, June 23-26, 1985, *Conference Record*, Vol. 1, pp. 336-343.
- Van Der Merwe, D. G.,* Hung, H-L. A., Cannitz, L.* and Eastman, L. F.,* "GaAs MBE Monolithic Low-Noise Amplifiers at X-Band," 15th European Microwave Conference, Paris, France, September 9-13, 1985, *Proc.*, pp. 919-924.
- Wickham, M. E., "Design and Development of an Advanced Microwave Power Leveling Loop," *International Telemetry Conference*, Las Vegas, NV, October 28-31, 1985, *Proc.*, Vol. 21, pp. 63-84.
- Williams, A. E., and Bonetti, R. R., "Design of Very Narrow Bandwidth Dielectric Resonator Microwave Filters," *Government Microcircuit Applications Conference*, Orlando, FL, November 5-7, 1985 *Digest*, pp. 341-342.
- Williams, A. E., Bonetti, R. R., Karimullah, K., and Piccinni, M., "Microwave Receive Filter for a Regenerative Repeater," 15th European Microwave Conference, Paris, France, September 9-13, 1985, *Proc.*, pp. 349-354.
- Williams, A. E., Bush, W. G., and Bonetti, R. R., "Predistorted Techniques for Multiple-Coupled Resonator Filters," *IEEE Transactions on Microwave Theory and Techniques*, Vol. MTT-32, No. 5, May 1985, pp. 402-406.
- Williams A. E., Tang, W. C.,* and Inher, C.,* "High Power Output Multiplexer for First DBS Application," 15th European Microwave Conference, Paris, France, September 9-13, 1985, *Proc.*, pp. 355-363.
- Wolejsza, C. J., Snyder, J. S., and Kappes, J. M., "120-Mbit/s TDMA Modem and FEC Codec Performance," *COMSAT Technical Review*, Vol. 15, No. 2B, Fall 1985, pp. 423-465 [CTR85/293].
- Zaghoul, A. I., "Statistical Analysis of e.i.r.p. Degradation in Antenna Arrays," *IEEE Transactions on Antennas and Propagation*, Vol. AP-33, No. 2, February 1985, pp. 217-221.

PATENTS

The following patents were issued to employees (and former employees) of COMSAT Laboratories in 1985.

- Childs, W. H., "Simplified Minimum Shift Keying (MSK) Modulator," Patent No. 4,500,856, issued February 19, 1985.
- Virupaksha, K., "Variable Slope Delta Coding Processor Using Adaptive Prediction," Patent No. 4,501,001, issued February 19, 1985.
- Virupaksha, K., and Suyderhoud, H. G., "An Adaptive Gain Variable Bit Rate NIC Processor," Patent No. 4,500,842, issued February 19, 1985.

*Non-COMSAT author.



Dr. Ashok Kaul (center) displays the 1983 COMSAT Research Award which has been awarded by Dr. John V. Evans (second from left) to (from left to right) Messrs. A. Agarwal, W. Redman, J. McKoskey, and W. Mogart. Mr. B. Hung is not shown.

HONORS AND AWARDS

Each year a number of honors and awards are received by COMSAT Laboratories' personnel for their work in advancing the state of the art of satellite communications technology. This year, the COMSAT Research Award, which recognizes individuals who have made outstanding technical contributions to the work of the Laboratories, was awarded to Messrs W. Redman, A. Agarwal, B. Hung, J. McCoskey, and W. Morgart for conceiving and implementing the Programmable Interface Processor (PIP). The microprocessor technology which they developed integrates the operation of many individual microprocessors into a single more powerful processor, leading to the development of the PIP and the COMSAT Microprocessor Operating System (COSMOS) which formed the basis for STARCOM.

Mark Jennings, a co-op student from MIT, was selected as a Rhodes Scholar for the Fall 1985 term at Oxford University. He received his B.S. and M.S. in Electrical Engineering in June 1985.

Amir I. Zaghloul and Carey M. Rappaport were awarded the 1986 H. A. Wheeler Applications Prize for their paper entitled "Optimized Three-Dimensional Lenses for Wide-Angle Scanning." The award was presented at the IEEE AP-S Symposium.

Also honored for her efforts was Ann Tulintseff, a COMSAT Laboratories' co-op student from MIT. Her paper, entitled "Experiment and Analysis of a Circularly Polarized Electromagnetically Coupled Microstrip Antenna," received second prize in the student paper competition at the USNC-URSI National Radio Science Meeting in Boulder, Colorado.



Amir Zaghloul



Carey Rappaport



Ann Tulintseff

COMSAT Laboratories
Clarksburg, Maryland 20871



Telephone (301) 428-4000
Telex: 90-8753