

**MONTGOMERY COUNTY HISTORIC PRESERVATION COMMISSION**  
**STAFF REPORT**

<b>Address:</b>	7209 Willow Avenue, Takoma Park	<b>Meeting Date:</b>	8/14/2024
<b>Resource:</b>	Outstanding Resource Takoma Park Historic District	<b>Report Date:</b>	8/7/2024
<b>Applicant:</b>	Tina Crouse	<b>Public Notice:</b>	7/31/2024
<b>Review:</b>	HAWP	<b>Tax Credit:</b>	No
<b>Permit Number:</b>	1077703	<b>Staff:</b>	Chris Berger
<b>PROPOSAL:</b>	Solar panel installation.		

**STAFF RECOMMENDATION**

Staff recommends that the HPC **approve with two conditions** the HAWP application with final approval delegated to staff:

1. The three panels proposed toward the front wall plane cannot be installed. The applicant has the option to instead install panels on the one-story rear additions but only after staff reviews and approves a revised plan.
2. The applicant must provide a plan to show how the conduit will extend from the load center to the panels on the roof. The conduit cannot damage the eaves.

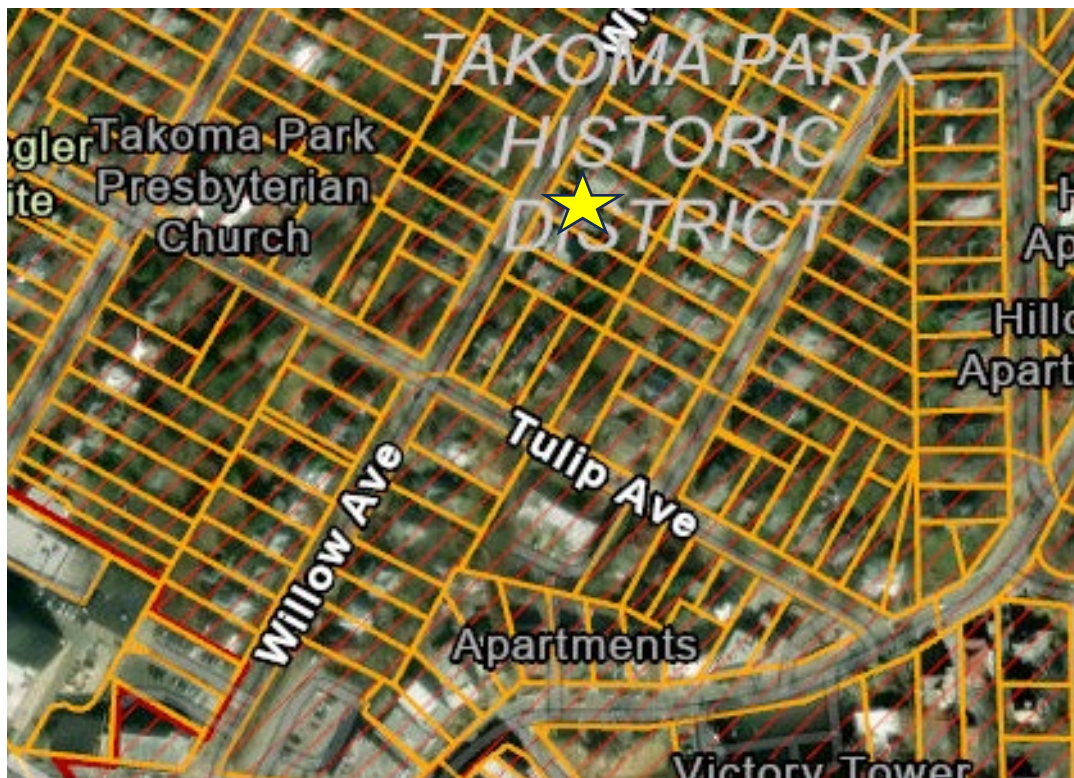

*Figure 1: The subject property at 7209 Willow Avenue is denoted with the yellow star. The Takoma Park Historic District boundaries are marked in red.*

## ARCHITECTURAL DESCRIPTION

SIGNIFICANCE: Outstanding Resource within the Takoma Park Historic District  
STYLE: Craftsman  
DATE: circa 1910s

The two-story, rectangular-shaped residence measures 1,716 square feet (*Figures 2-3*). A full-width, one story front porch extends along the front elevation and is covered with a shed roof. The second floor is covered with a gable roof with symmetrically placed shed roof dormers to either side. One-story additions on the rear elevation have shed and gable roofs. All roofs are covered with 3-tab asphalt shingles.



*Figure 2: The front and left-side elevations of 7209 Willow Ave.*

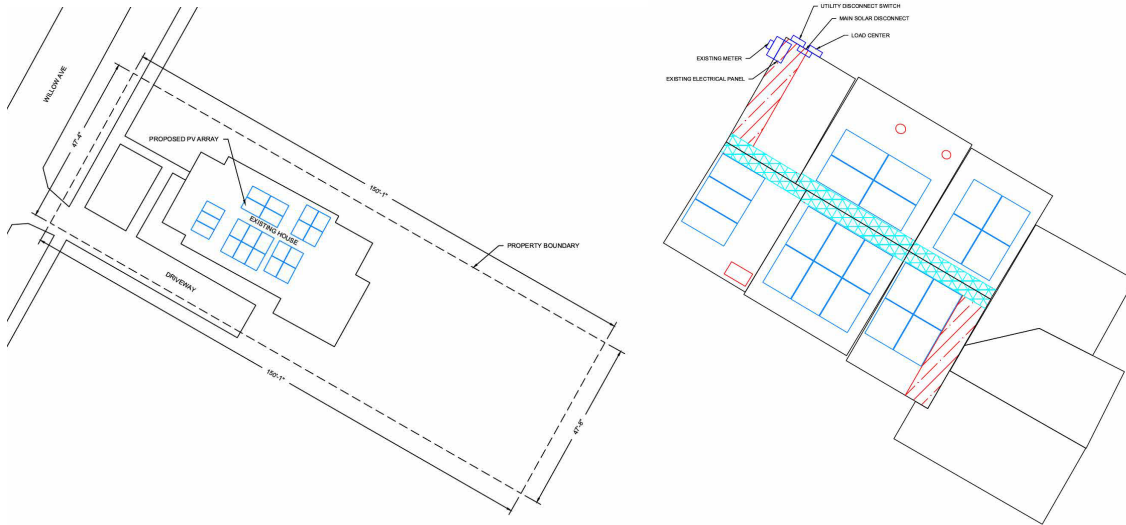



*Figure 3: The front and right-side elevations of 7209 Willow Ave.*

## **PROPOSAL**

The applicant proposes to install 21 roof-mounted solar panels in five arrays on top of the two-story roof (*Figures 4-5*). No panels will be placed on the shed roof on the one-story front porch or the gable and shed roofs on the one-story rear additions. On the south-facing roofline, three panels will be installed at the edge of the second floor roofline, six panels will be installed on the shed dormer, and four panels will be installed on the rear second floor roofline. On the north-facing roof, four panels will be installed on the shed dormer, and four panels will be installed on the rear second floor roofline. The LONGHi Hi-Mo5 LR5-54HABB panels will each measure 5.65-by-3.72 feet. The panels will be mounted to the asphalt shingle roof with SnapNrack mounts. The load center and disconnect switch will be installed on the north (left side) elevation proximate to the home's existing meter and electrical panel, which are located on the front wall plane.



**Figure 4:** The site plan (left) shows the proposed solar panel locations and the building’s orientation toward Willow Avenue. The roof plan (right) shows the proposed location of the solar panels and the equipment location on the left-side elevation near the front wall plane.

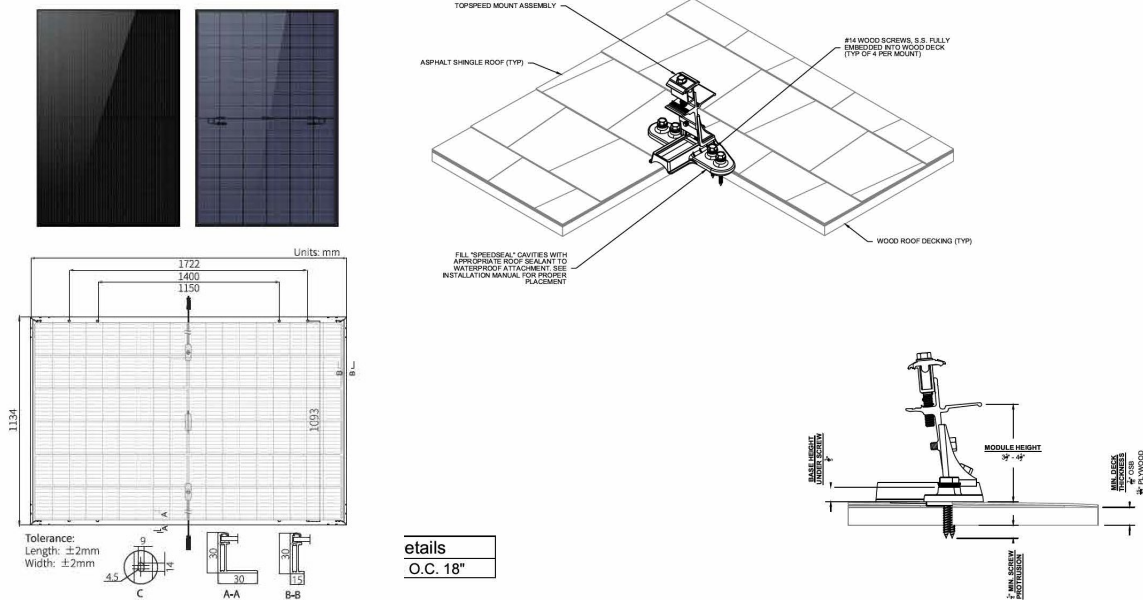

**Figure 5:** The specifications for the solar panels (left), and the installation details for the SnapNrack mounts (right).

**APPLICABLE GUIDELINES**

The Historic Preservation Office and Historic Preservation Commission (HPC) consult several documents when reviewing alterations and new construction within the Takoma Park Historic District. These documents include the historic preservation review guidelines in the approved and adopted amendment for the *Takoma Park Historic District (Guidelines)*, *Montgomery County Code Chapter 24A (Chapter 24A)*, and the *Secretary of the Interior’s Standards for Rehabilitation (Standards)*, and the HPC’s *Policy No. 20-01 ADDRESSING EMERGENCY CLIMATE MOBILIZATION THROUGH THE INSTALLATION OF ROOF-MOUNTED SOLAR PANELS*. The pertinent information in these four documents is outlined below.



### ***Takoma Park Historic District Guidelines***

There are two broad planning and design concepts which apply to all categories. These are:

- The design review emphasis will be restricted to changes that are all visible from the public right-of-way, irrespective of landscaping or vegetation (it is expected that the majority of new additions will be reviewed for their impact on the overall district), and
- The importance of assuring that additions and other changes to existing structures act to reinforce and continue existing streetscape, landscape, and building patterns rather than to impair the character of the historic district.

Outstanding Resources have the highest level of architectural and/or historical significance. While they will receive the most detailed level of design review, it is permissible to make sympathetic alterations, changes and additions. The guiding principles to be utilized by the Historic Preservation Commission are the *Secretary of the Interior's Standards for Rehabilitation*

Specifically, some of the factors to be considered in reviewing HAWPs on Outstanding Resources:

Plans for all alterations should be compatible with the resource's original design; additions, specifically, should be sympathetic to existing architectural character, including massing, height, setback, and materials;

Emphasize placement of major additions to the rear of existing structures so that they are less visible from the public right-of-way;

While additions should be compatible, they are not required to be replicative of earlier architectural styles;

Preservation of original and distinctive architectural features, such as porches, dormers, decorative details, shutters, etc. is encouraged;

Preservation of original windows and doors, particularly those with specific architectural importance, and of original size and shape of openings is encouraged;

Preservation of original building materials and use of appropriate, compatible new materials is encouraged;

All changes and additions should respect existing environmental settings, landscaping, and patterns of open space.

### ***Montgomery County Code, Chapter 24A-8***

The following guidance which pertains to this project are as follows:

- (b) The commission shall instruct the director to issue a permit, or issue a permit subject to such conditions as are found to be necessary to ensure conformity with the purposes and requirements of this chapter, if it finds that:
  - (1) The proposal will not substantially alter the exterior features of an historic site or historic resource within an historic district; or

- (2) The proposal is compatible in character and nature with the historical, archeological, architectural or cultural features of the historic site or the historic district in which an historic resource is located and would not be detrimental thereto or to the achievement of the purposes of this chapter;
- (d) In the case of an application for work on an historic resource located within an historic district, the commission shall be lenient in its judgment of plans for structures of little historical or design significance or for plans involving new construction, unless such plans would seriously impair the historic or architectural value of surrounding historic resources or would impair the character of the historic district. (Ord. No. 9-4, § 1; Ord. No. 11-59.)

***Secretary of the Interior’s Standards for Rehabilitation***

The Secretary of the Interior defines rehabilitation as “the act or process of making possible a compatible use for a property through repair, alterations, and additions while preserving those portions or features, which convey its historical, cultural, or architectural values.” The applicable *Standards* are as follows:

2. The historic character of a property shall be retained and preserved. The removal of historic materials or alteration of features and spaces that characterize a property shall be avoided.
9. New additions, exterior alterations, or related new construction shall not destroy historic materials that characterize the property. The new work shall be differentiated from the old and shall be compatible with the massing, size, scale, and architectural features to protect the historic integrity of the property and its environment.
10. New additions and adjacent or related new construction shall be undertaken in such a manner that if removed in the future, the essential form and integrity of the historic property and its environment would be unimpaired.

***Historic Preservation Commission Policy No. 20-01: Addressing Emergency Climate Mobilization Through The Installation of Roof-Mounted Solar Panels***

Now, THEREFORE:

WHEREAS, Historic Area Work Permit decisions are guided by the criteria in Section 24A, The Secretary of the Interior’s Standards for Rehabilitation, and pertinent guidance from applicable master plan amendments and/or site or district-specific studies;

WHEREAS, The Secretary of the Interior’s Standards for Rehabilitation as interpreted by the National Park Service limit the placement of rooftop solar panels under Standards 2, 9, and 10 to less conspicuous locations;

WHEREAS, the County Council has established a Climate Emergency;

WHEREAS, the Historic Preservation is a body established by the County Executive and County Council;

WHEREAS, Section 24-8(b)(6) states, “In balancing the interest of the public in preserving the historic site or historic resource located within an historic district, with the interests of the public from the use and benefit of the alternative proposal, the general public welfare is better served by granting the permit;”

WHEREAS, the widespread use of solar panels, both for hot water and for electricity production, will reduce greenhouse gases in the county, in accordance with the aims of the Emergency Climate



Mobilization resolution (Resolution No.: 18-974), it shall be the policy of the Historic Preservation Commission that:

1. The preferred locations for solar panel installation(s) on a designated historic site or an historic resource located within an historic district is a) on the rear of the property, b) on non-historic building additions, c) on accessory structures, or d) in ground-mounted arrays;
2. If it is not feasible to install solar panels in one of the identified preferred locations due to resource orientation or other site limitations; and,
3. The roof is determined to be neither architecturally significant, nor a character-defining feature of the resource, nor is it a slate or tile roof, that unless it can be demonstrated that the solar array will be installed without damaging the historic character of the resource or historic fabric; then
4. The public welfare is better served by approving a Historic Area Work Permit for solar panels on all visible side or front roof slopes under Section 24A-8(b)(6).
5. A Historic Area Work Permit (HAWP) is required for all work referenced in this policy.

### **STAFF DISCUSSION**

Staff supports the installation of the 18 solar panels on the dormers and toward the rear wall plane and recommends approval.

The HPC and staff utilize *Policy Guidance #20-01: Solar Technology* as the baseline for their review and to articulate their findings in the review of solar technology. The most preferred location for solar systems is a freestanding array in the rear yard, but this location is not feasible at the subject property due to the size of the lot and existing tree canopy. The second preferred location is a roof-mounted array on an accessory or non-historic building, which do not appear to be present on the property. The third and fourth preferred locations are roof-mounted arrays on a non-historic addition or on the rear of the original house, respectively. The building does have rear, one-story additions but no panels were proposed on those locations because of the partial tree canopy.

The Policy states that if it is not feasible to install panels in one of the identified preferred locations and the roof is determined to be neither architecturally significant, a character-defining feature, or slate or tile—none of which are the case at the subject property—then the panels can be installed unless they will damage the historic character of the resource. Staff finds the 18 panels proposed on the dormers and rear portion of the second-story roof will be minimally visible from the right of way because of their height above the ground, and they will be arranged in a symmetric pattern to minimize their visual impact. In keeping with the *Guidelines* and Chapter 24A-8(b)(1) and (2), the panels will not substantially alter the exterior features of the historic resource within the historic district and are compatible the district's character.

However, staff does not support the installation of the three panels proposed for installation closest to the front wall plane. As an Outstanding Resource, the *Guidelines* instruct that the subject property is to receive the most detailed level of design review. Unlike the 18 panels proposed farther back on the roof, these three panels at the roof's edge toward the front wall plane will be more readily visible to passers-by who are traveling northbound in the Willow Avenue right of way. The three panels will be prominently visible from the right of way—located approximately 25 feet away—and the proposed placement of the

array will adversely alter the exterior features of the historic site and will be incompatible to the character of the historic property and not meet Chapter 24A-8(b)(1) and (2) and the HPC's solar policy.

Solar panels are an established feature on the roofs of nearby residences, but in all instances the panels were set back from the wall plane to minimize visibility, unlike what is proposed for the three panels at the subject property (*Figure 8*). In 2022, the HPC staff approved 34 panels on the roof of the Outstanding Resource across the street from the subject property at 7212 Willow Ave. with HAWP #988569.<sup>1</sup> Staff had the authority to approve because the panels, which were set back from the roof edge, because they were not to be readily visible from the right of way. At its November 15, 2023, meeting the HPC approved the installation of 28 solar panels on the Contributing Resource next door to the subject property at 7207 Willow Avenue with HAWP #1046207 (*Figures 6-7*).<sup>2</sup> The building, a one-story Craftsman style Bungalow, has a front-oriented gable roof with panels installed to either side that are visible from the right of way. The solar equipment and conduit is located on a side elevation close to the front wall plane, similar to what is proposed at the subject property at 7209 Willow. The Non-Contributing Resource at 7205 Willow Ave. also has panels visible from the right of way, and they too are set back a few feet from the front roof edge.<sup>3</sup>



*Figure 6: The HPC approved solar panels on the adjacent Contributing Resource at 7207 Willow Avenue (indicated with a red arrow) at the November 15, 2023, meeting. The subject property at 7209 Willow Avenue is in the foreground.*

<sup>1</sup> The approved plans for HAWP #988569 are available here:

[https://mcatlas.org/tiles6/06\\_HistoricPreservation\\_PhotoArchives/HAWP/05-04-2022/7212%20Willow%20Avenue,%20Takoma%20Park%20-%20988569%20-%20Approval.pdf](https://mcatlas.org/tiles6/06_HistoricPreservation_PhotoArchives/HAWP/05-04-2022/7212%20Willow%20Avenue,%20Takoma%20Park%20-%20988569%20-%20Approval.pdf)

<sup>2</sup> The staff report for HAWP # 1046207 is available here: <https://montgomeryplanning.org/wp-content/uploads/2023/11/I.A-7207-Willow-Avenue-Takoma-Park-1046207.pdf>

The approved plan for HAWP # 1046207 is available here:

[https://mcatlas.org/tiles6/06\\_HistoricPreservation\\_PhotoArchives/HAWP/11-15-2023/7207%20Willow%20Avenue,%20Takoma%20Park%20-%201046207%20-%20Approval.pdf](https://mcatlas.org/tiles6/06_HistoricPreservation_PhotoArchives/HAWP/11-15-2023/7207%20Willow%20Avenue,%20Takoma%20Park%20-%201046207%20-%20Approval.pdf)

<sup>3</sup> The staff report for HAWP # 975969 is available here: <https://montgomeryplanning.org/wp-content/uploads/2021/12/I.C-7205-Willow-Avenue-Takoma-Park-%E2%80%93-975969.pdf>





*Figure 7: The HPC approved solar panels on the adjacent Contributing Resource at 7207 Willow Avenue (indicated with a red arrow) at the November 15, 2023, meeting. The subject property at 7209 Willow Avenue is in the background.*



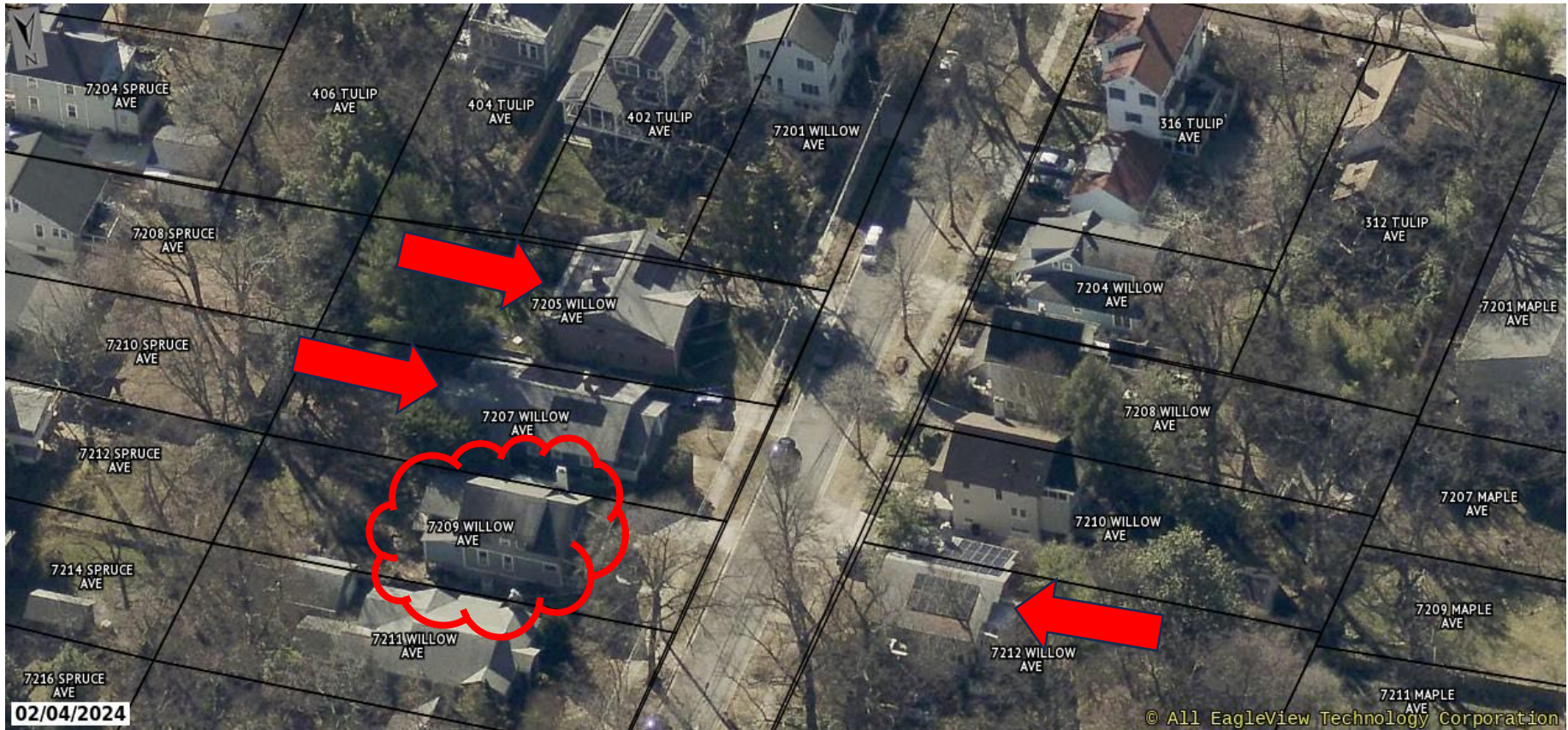

**Figure 8:** The subject property at 7209 Willow Ave. is clouded in red. The panels present on nearby buildings are indicated with red arrows, including the Outstanding Resource at 7212 Willow Ave.; the Contributing Resource at 7207 Willow Ave.; and the Non-Contributing Resource at 7205 Willow Ave. The existing panels on all three buildings are set back from the front wall plane to minimize their visual impact. Source: CONNECTExplorer



According to the applicant, the panels toward the front wall plane will produce an average of 462 Kilowatthour (kWh) per panel annually. The other roof planes toward the back will produce an average of 370 kWh per panel annually. As proposed, the 21 panels will produce 94 percent of the home's energy needs. Staff recognizes the need to maximize the solar energy potential of the property and notes that no panels are proposed for the one-story rear additions because the applicant said the roofs are shaded by trees, but the provided shade map does indicate the potential for some solar energy output on those roofs (**Figure 9**). Staff recommends a condition that the applicant have the option to install panels on the rear addition, with a revised plan subject only to staff review and approval.



**Figure 9: The shade map provided by the applicant shows the highest potential panel output in yellow. Orange indicates the middle point of production, and purple is the least productive.**

Staff seeks details on the path of the conduit to be installed from the load center on the left-side elevation to the panels on the roof and seeks confirmation that the conduit will not damage the roof eaves.

After full and fair consideration of the applicant's submission, staff finds the proposal, as modified by the conditions, consistent with the Criteria for Issuance in Chapter 24A-8(b)(1), (2), and (d), having found the proposal is consistent with the *Secretary of the Interior's Standards for Rehabilitation* #2, 9, and 10, and *Takoma Park Historic District Guidelines*, and the HPC's Policy No. 20-01 as outlined above.

**STAFF RECOMMENDATION**

Staff recommends that the Commission **approve with two conditions** the HAWP application with final approval delegated to staff:

1. The three panels proposed toward the front wall plane cannot be installed. The applicant has the option to instead install panels on the one-story rear additions but only after staff reviews and approves a revised plan.
2. The applicant must provide a plan to show how the conduit will extend from the load center to the panels on the roof. The conduit cannot damage the eaves.

under the Criteria for Issuance in Chapter 24A-8(b)(1), (2), and (d) and Chapter 24A-8(d), having found that the proposal will not substantially alter the exterior features of the historic resource and is compatible in character with the purposes of Chapter 24A;

*The Takoma Park Historic District Guidelines;*

and with the *Secretary of the Interior's Standards for Rehabilitation* # 2, 9, and 10;

and with the *Historic Preservation Commission Policy No. 20-01: Addressing Emergency Climate Mobilization Through The Installation of Roof-Mounted Solar Panels;*

and with the general condition that the applicant shall present an electronic set of drawings, if applicable, to HPC staff for review and stamping prior to submission for the Montgomery County Department of Permitting Services (DPS) building permits;

and with the general condition that final project design details, not specifically delineated by the Commission, shall be approved by HPC staff or brought back to the HPC as a revised HAWP application at staff's discretion;

and with the general condition that the applicant shall notify the HPC staff if they propose to make **any alterations** to the approved plans. Once the work is completed the applicant will contact the staff person assigned to this application at 301-563-3400 or [chris.berger@montgomeryplanning.org](mailto:chris.berger@montgomeryplanning.org) to schedule a follow-up site visit.





**APPLICATION FOR  
HISTORIC AREA WORK PERMIT**  
HISTORIC PRESERVATION COMMISSION  
301.563.3400

**FOR STAFF ONLY:**  
HAWP# 1077703  
DATE ASSIGNED \_\_\_\_\_

**APPLICANT:**

Name: Tina Crouse  
Address: 7209 Willow Avenue  
Daytime Phone: (301) 502-5930

E-mail: judyapp50@gmail.com  
City: Takoma Park Zip: 20912  
Tax Account No.: 13-01077338

**AGENT/CONTACT (if applicable):**

Name: Tina Crouse  
Address: 14880 Sweitzer Lane  
Daytime Phone: 410-579-2009

E-mail: permitting@solarenergyworld.com  
City: Laurel Zip: MD  
Contractor Registration No.: 127353

**LOCATION OF BUILDING/PREMISE:** MIHP # of Historic Property 1077703

Is the Property Located within an Historic District?  Yes/District Name Takoma Park  
 No/Individual Site Name \_\_\_\_\_

Is there an Historic Preservation/Land Trust/Environmental Easement on the Property? If YES, include a map of the easement, and documentation from the Easement Holder supporting this application.

Are other Planning and/or Hearing Examiner Approvals /Reviews Required as part of this Application? (Conditional Use, Variance, Record Plat, etc.?) If YES, include information on these reviews as supplemental information.

Building Number: 7209 Street: Willow Avenue  
Town/City: Takoma Park Nearest Cross Street: Tulip Avenue  
Lot: 9 Block: 8 Subdivision: 0025 Parcel: 0000

**TYPE OF WORK PROPOSED: See the checklist on Page 4 to verify that all supporting items for proposed work are submitted with this application. Incomplete Applications will not be accepted for review. Check all that apply:**

- |   |  |  |
|---|--|--|
| <input type="checkbox"/> New Construction   | <input type="checkbox"/> Deck/Porch          | <input type="checkbox"/> Shed/Garage/Accessory Structure |
| <input type="checkbox"/> Addition           | <input type="checkbox"/> Fence               | <input checked="" type="checkbox"/> Solar                |
| <input type="checkbox"/> Demolition         | <input type="checkbox"/> Hardscape/Landscape | <input type="checkbox"/> Tree removal/planting           |
| <input type="checkbox"/> Grading/Excavation | <input type="checkbox"/> Roof                | <input type="checkbox"/> Window/Door                     |
|   |  | <input type="checkbox"/> Other: _____                    |

I hereby certify that I have the authority to make the foregoing application, that the application is correct and accurate and that the construction will comply with plans reviewed and approved by all necessary agencies and hereby acknowledge and accept this to be a condition for the issuance of this permit.

Tina Crouse \_\_\_\_\_ 07/09/2024 \_\_\_\_\_  
Signature of owner or authorized agent Date

**HAWP APPLICATION: MAILING ADDRESSES FOR NOTIFYING**  
 [Owner, Owner's Agent, Adjacent and Confronting Property Owners]

<p><b>Owner's mailing address</b></p> <p>Judith Appelbaum          7209 Willow Avenue          Takoma Park, MD 20912</p>	<p><b>Owner's Agent's mailing address</b></p> <p>Solar Energy World          14880 Sweitzer Lane          Laurel, MD 20707</p>
<p align="center"><b>Adjacent and confronting Property Owners mailing addresses</b></p>	
<p>7207 Willow Avenue,          Takoma Park, MD 20912</p> <p>(Adjacent Property)</p>	<p>7211 Willow Avenue          Takoma Park, MD 20912</p> <p>(Adjacent Property)</p>
<p>7212 Willow Avenue          Takoma Park, MD 20912</p> <p>(Confronting Property)</p>	<p>7210 Willow Avenue          Takoma Park, MD 20912</p> <p>(Confronting Property)</p>
<p>7214 Spruce Avenue, Takoma Park MD 20912</p> <p>7212 Spruce Avenue, Takoma Park MD 20912</p> <p>7210 Spruce Avenue, Takoma Park MD 20912</p>	

Description of Property: Please describe the building and surrounding environment. Include information on significant structures, landscape features, or other significant features of the property:

-Property Buildt in 1913

Description of Work Proposed: Please give an overview of the work to be undertaken:

- Install (21) roof mounted solar panels, 8.40 kW
- Galvanized steel conduit to run from equipment along and tucked into the chimney line to attic.
- Utility disconnect to be installed next to utility meter along with the electrical combiner box.
- Micro Inverters to be installed under each panel.



Work Item 1: \_\_\_\_\_

Description of Current Condition:

Proposed Work:

Work Item 2: \_\_\_\_\_

Description of Current Condition:

Proposed Work:

Work Item 3: \_\_\_\_\_

Description of Current Condition:

Proposed Work:

**HISTORIC AREA WORK PERMIT  
CHECKLIST OF  
APPLICATION REQUIREMENTS**

	Required Attachments						
Proposed Work	I. Written Description	2. Site Plan	3. Plans/Elevations	4. Material Specifications	5. Photographs	6. Tree Survey	7. Property Owner Addresses
New Construction	*	*	*	*	*	*	*
Additions/Alterations	*	*	*	*	*	*	*
Demolition	*	*	*		*		*
Deck/Porch	*	*	*	*	*	*	*
Fence/Wall	*	*	*	*	*	*	*
Driveway/Parking Area	*	*		*	*	*	*
Grading/Excavation/Landscaping	*	*		*	*	*	*
Tree Removal	*	*		*	*	*	*
Siding/ Roof Changes	*	*	*	*	*		*
Window/ Door Changes	*	*	*	*	*		*
Masonry Repair/ Repoint	*	*	*	*	*		*
Signs	*	*	*	*	*		*



Front of Home



Back of Home





Left Side of Home



Right Side of Home



Before Utility Install



After Utility Install

Staff Note: This will not be installed. See email on next page.

**From:** [Tina Crouse](#)  
**To:** [Berger, Chris](#); [SEW - Permitting](#)  
**Subject:** Re: 7209 Willow Avenue, Takoma Park - HAWP No. 1077703  
**Date:** Monday, August 5, 2024 11:20:32 AM  
**Attachments:** [image001.png](#)  
[colorhorizontalwithslogan\\_6ff11b2f-7a37-4992-acbc-f3926d4721d8.png](#)

---

**[EXTERNAL EMAIL]** Exercise caution when opening attachments, clicking links, or responding.

Chris,

That was by mistake. I thought I erased that picture and sent a different one.

## Tina Crouse

Permits Administrator

P: (866) 856-4580



---

**From:** Berger, Chris <Chris.Berger@montgomeryplanning.org>  
**Sent:** Monday, August 5, 2024 10:55 AM  
**To:** Tina Crouse <tcrouse@solarenergyworld.com>; SEW - Permitting <Permitting@solarenergyworld.com>  
**Subject:** RE: 7209 Willow Avenue, Takoma Park - HAWP No. 1077703

**[EXTERNAL EMAIL]** This email was sent from outside of the organization. DO NOT CLICK links or attachments unless you recognize the sender and know the content is safe.

Good morning,

I have a question about the proposed conduit for this property that I'm hoping you can help me answer as we wrap up the staff report before it's posted Wednesday.

In the attached photo, the conduit is to run under the roofline of the porch. I understand why it will need to run along the wall to reach the arrays on the 2<sup>nd</sup> floor, but can you please explain why it needs to go under the porch roofline?

I appreciate you help,

## Chris Berger, AICP

Cultural Resources Planner III

Montgomery County Planning Department



2425 Reedie Drive, 13<sup>th</sup> Floor, Wheaton, MD 20902  
[Chris.Berger@montgomeryplanning.org](mailto:Chris.Berger@montgomeryplanning.org)  
Office: 301-495-4571

---

**From:** Berger, Chris  
**Sent:** Wednesday, July 31, 2024 1:59 PM  
**To:** Tina Crouse <[tcrouse@solarenergyworld.com](mailto:tcrouse@solarenergyworld.com)>; SEW - Permitting <[Permitting@solarenergyworld.com](mailto:Permitting@solarenergyworld.com)>  
**Subject:** RE: 7209 Willow Avenue, Takoma Park - HAWP No. 1077703

Received—thank you.

**Chris Berger, AICP**

**Cultural Resources Planner III**  
Montgomery County Planning Department  
2425 Reedie Drive, 13<sup>th</sup> Floor, Wheaton, MD 20902  
[Chris.Berger@montgomeryplanning.org](mailto:Chris.Berger@montgomeryplanning.org)  
Office: 301-495-4571

---

**From:** Tina Crouse <[tcrouse@solarenergyworld.com](mailto:tcrouse@solarenergyworld.com)>  
**Sent:** Wednesday, July 31, 2024 12:23 PM  
**To:** Berger, Chris <[Chris.Berger@montgomeryplanning.org](mailto:Chris.Berger@montgomeryplanning.org)>; SEW - Permitting <[Permitting@solarenergyworld.com](mailto:Permitting@solarenergyworld.com)>  
**Subject:** Re: 7209 Willow Avenue, Takoma Park - HAWP No. 1077703

**[EXTERNAL EMAIL]** Exercise caution when opening attachments, clicking links, or responding.

Chris,

Please see attached for the documentation you requested.

Please contact me if you have any questions.

**Tina Crouse**

Permits Administrator  
**P:** [\(866\) 856-4580](tel:(866)856-4580)



---

**From:** Berger, Chris <[Chris.Berger@montgomeryplanning.org](mailto:Chris.Berger@montgomeryplanning.org)>  
**Sent:** Friday, July 26, 2024 3:53 PM  
**To:** SEW - Permitting <[Permitting@solarenergyworld.com](mailto:Permitting@solarenergyworld.com)>;  
[judyapp50@gmail.com](mailto:judyapp50@gmail.com) <[judyapp50@gmail.com](mailto:judyapp50@gmail.com)>

**Subject:** 7209 Willow Avenue, Takoma Park - HAWP No. 1077703

**[EXTERNAL EMAIL]** This email was sent from outside of the organization. DO NOT CLICK links or attachments unless you recognize the sender and know the content is safe.

Hello,

The application is tentatively scheduled for Historic Preservation Review at its Wednesday, August 14, meeting. Staff did a preliminary review of the solar panel application and has the following comments:

- Please email me a heat map plan for the roof.
- Please provide specifications or representative photos for the utility disconnect switch, main solar disconnect, and load center so we can better understand the dimensions of these features.
- Please provide a statement explaining why the conduit, disconnect switch, solar disconnect, and load center must be located at the front of the house as proposed and what can be done to minimize its visual impact.

We would need to have this additional information emailed to me by Thursday, August 1.

**Chris Berger, AICP**

**Cultural Resources Planner III**

Montgomery County Planning Department

2425 Reedie Drive, 13<sup>th</sup> Floor, Wheaton, MD 20902

[Chris.Berger@montgomeryplanning.org](mailto:Chris.Berger@montgomeryplanning.org)

Office: 301-495-4571



# DAVID C. HERNANDEZ, PE

513-418-8812 

4912 Prospect Ave., Blue Ash OH 45242 

davehernandezpe@gmail.com 

DATE: July 8, 2024

RE: 7209 Willow Ave, Takoma Park, MD 20912

To Whom It May Concern,

As per your request, Exactus Energy has conducted a site assessment of the building at the above address.

PV solar panels are proposed to be installed on roof areas as shown in the submitted plans. The panels are clamped and attached to the roof deck with a rail-less mounting system. The PV system (PV modules, racking, mounting hardware, etc.) shall be installed according to the manufacturer's approved installation specifications. The Engineer of Record and Exactus Energy claim no responsibility for misuse or improper installation.

It was found that the roof systems satisfactorily meet the applicable code standards included in the IBC 2018, IRC 2018 and ASCE 7-16 as well as the design criteria shown below:

Design Criteria:

Risk Category	= II
Exposure Category	= B
Wind speed	= 115 mph
Ground snow load	= 30 psf
Roof dead load	= 12 psf
Solar system dead load	= 3 psf

Overall, the roof system integrity is adequate to support the PV alteration with no modifications or reinforcements as required per 2018 IEBC Sections 502.4 and 502.5.

This letter was completed in accordance to recognized design standards, professional engineering experience, and judgement. Prior to installation, the on-site contractor must notify Exactus Energy if there are any discrepancies, or damages to the members, that was not addressed in the plan set.

If you have any further questions, please do not hesitate to contact me.

Acknowledged by:

David C. Hernandez, PE Digitally signed by David C. Hernandez,  
Date: 2024.07.08 12:11:51 -04:00



PROFESSIONAL CERTIFICATION. I HEREBY CERTIFY THAT THESE DOCUMENTS WERE PREPARED OR APPROVED BY ME, AND THAT I AM A DULY LICENSED PROFESSIONAL ENGINEER UNDER THE LAWS OF THE STATE OF MARYLAND, LICENSE NO. 49993, EXP 10/06/2024  
Sgd: 07/08/24



Project Property Owner Judith Appelbaum & Elizabeth Cohn

Address 7209 Willow Ave, Takoma Park, MD 20912

I reviewed the design of the photovoltaic (PV) system, as designed by the manufacturer, and the design criteria utilized for the mounting equipment and panel mounting assembly (rack system) for the installation of (21) panels supported by the rack system, as shown on the drawings prepared for the above referenced address. I certify that the configurations and design criteria meet the standards and requirements of the International Residential Code (IRC) and International Existing Building Code (IEBC) adopted by Montgomery County in COMCOR08.00.02.

The attachment of the rack system to the building at the above address, including the location, number, and type of attachment points; the number of fasteners per attachment point; and the specific type of fasteners (size, diameter, length, minimum embedment into structural framing, etc.) meets the standards and requirements of the IRC and IEBC adopted by Montgomery County in COMCOR 08.00.02.

I evaluated the existing roof structure of the building at the above address and analyzed its capacity to support the additional loads imposed by the PV system. I certify that no structural modifications of the existing roof structure are required. The existing roof structure meets the standards and requirements of the IRC and IEBC, adopted by Montgomery County in COMCOR 08.00.02, necessary to support the PV system.

I evaluated the existing roof structure of the building at the above address and analyzed its capacity to support the additional loads imposed by the PV system. Structural modifications of the existing roof structure are required. I certify that the roof structure, as modified on the drawings for this project, will support the additional loads imposed by the PV system. I further certify that design of the modified roof structure meets the standards and requirements of the IRC and IEBC, adopted by Montgomery County in COMCOR 08.00.02.

I prepared or approved the construction documents for the mounting equipment, rack system, roof structure for this project.

49993  
Maryland PE License Number

Date July 8, 2024

Signature David C. Hernandez, PE  
Digitally signed by David C. Hernandez,  
Date: 2024.07.08 12:11:51 -04:00

Seal



PROFESSIONAL CERTIFICATION. I HEREBY CERTIFY THAT THESE DOCUMENTS WERE PREPARED OR APPROVED BY ME, AND THAT I AM A DULY LICENSED PROFESSIONAL ENGINEER UNDER THE LAWS OF THE STATE OF MARYLAND, LICENSE NO. 49993, EXP 10/06/2024.  
Sgd. 07/08/24

**Must be submitted with plans**





Property Owners Name: Judith Appelbaum

Property Owners Address: 7209 Willow Avenue, Takoma Park, MD 20912

Address of installation if different than owner's address:

---

I certify that:

- I prepared or approved the electrical drawings and related documents for the photovoltaic (PV) system at the above location.
- The design of the PV system, and all electrical Installations and equipment, meets the standards and requirements of the National Electrical Code as adopted by Montgomery County *in* COMCOR 17.02.01.
- I reviewed and completed the Worksheet for PV System, which was attached to the permit application for the PV system at the **above** location.

15732

State Master Electrician License Number

Date: 07/08/2024

Signature: *Matt Huan*

# City of Takoma Park

Housing and Community Development Department

Main Office 301-891-7119  
Fax 301-270-4568  
www.takomaparkmd.gov



7500 Maple Avenue  
Takoma Park, MD 20912

## MUNICIPALITY LETTER

July 09, 2024

**To:** Judith Appelbaum  
7209 Willow Avenue, Takoma Park, MD 20912  
judyapp50@gmail.com (301) 502-5930

**To:** Department of Permitting Services  
2425 Reddie Drive, 7<sup>th</sup> floor  
Wheaton, Maryland 20902

**From:** Planning and Development Services Division

### **THIS IS NOT A PERMIT – For Informational Purposes Only**

VALID FOR ONE YEAR FROM DATE OF ISSUE

The property owner is responsible for obtaining all required permits from Montgomery County and the City of Takoma Park. If this property is in the **Takoma Park Historic District**, it is subject to Montgomery County Historic Preservation requirements.

**Representative Name:** Solar Energy World-Tina Crouse                      tcrouse@solarenergyworld.com    410-579-2009  
**Location of Project:** 7209 Willow Avenue  
**Proposed Scope of Work:** Install (21) roof mounted solar panels, 8.40 kW

The purpose of this municipality letter is to inform you that the City of Takoma Park has regulations and city permit requirements that may apply to your project. This municipality letter serves as notification that, in addition to all Montgomery County requirements, you are required to comply with all City permitting requirements, including:

- Tree Impact Assessment/Tree Protection Plan
- Stormwater management
- City Right of Way

Failure to comply with these requirements could result in the issuance of a Stop Work Order and other administrative actions within the provisions of the law. Details of Takoma Park's permit requirements are attached on page 2.

The issuance of this letter does not indicate approval of the project nor does it authorize the property owner to proceed with the project. The City retains the right to review and comment on project plans during the Montgomery County review process.



# City Of Takoma Park

The City of Takoma Park permits for the following issues:

## Tree Impact Assessment/Tree Protection Plan/Tree Removal Application:

Construction activities that occur within 50 feet of any urban forest tree (7 and 5/8" in trunk diameter or greater), located on the project property or on an adjacent property, may require a Tree Impact Assessment and possibly a Tree Protection Plan Permit. Make sure to submit a request for a Tree Impact Assessment and schedule a site visit with the City's Urban Forest Manager if any urban forest tree is in the vicinity of proposed construction activities. See the Tree Permits section of the City website for the specific conditions in which a Tree Impact Assessment is required. Depending on the Urban Forest Manager's conclusion following the Tree Impact Assessment, you may need to prepare a full Tree Protection Plan and apply for a Tree Protection Plan Permit as well. Separately, the removal of any urban forest tree will require a Tree Removal Permit application. The tree ordinance is detailed in the City Code, section 12.12. For permit information check: <https://takomaparkmd.gov/services/permits/tree-permits>. The City's Urban Forest Manager can be reached at 301-891-7612 or [urbanforestmanager@takomaparkmd.gov](mailto:urbanforestmanager@takomaparkmd.gov).

## Stormwater Management:

If you plan to develop or redevelop property, you may be required to provide appropriate stormwater management measures to control or manage runoff, as detailed in City Code section 16.04. All commercial or institutional development in the city must apply for a Stormwater Management Permit regardless of the size of the land disturbance. Additions or modifications to existing detached single-family residential properties do not require a Stormwater Management permit if the project does not disturb more than 5,000 square feet of land area. For more information visit: <https://takomaparkmd.gov/government/public-works/stormwater-management-program/>. The City Engineer should be contacted to determine if a City permit is required. The City Engineer can be reached at 301-891-7620.

## City Right of Way:

- To place a **construction dumpster or storage container** temporarily on a City right of way (usually an adjacent road), you will need to obtain a permit. A permit is not required if the dumpster is placed in a privately-owned driveway or parking lot.
- If you plan to install a new **driveway apron**, or enlarge or replace an existing driveway apron, you need a Driveway Apron Permit.
- If you plan to construct a **fence** in the City right of way, you need to request a Fence Agreement. If approved, the Agreement will be recorded in the Land Records of Montgomery County.

For more information and applications for City permits, see: <https://takomaparkmd.gov/services/permits/> or contact the Department of Public Works at 301-891-7633.

Failure to comply with the City's permitting requirements could result in the issuance of a Stop Work Order and other administrative actions within the provisions of the law.

eSigned via SeamlessDocs.com  
*Tina Crouse*  
Key: 38bf2056622713c0c6f79ea7ee94779a

Tina Crouse

07-08-2024

eSigned via SeamlessDocs.com  
*Takoma Park Planning Division*  
Key: 19fe84f23e68a3ff457621f059d5fb4

07-09-2024



# SnapNrack™

Solar Mounting Solutions

---

## TopSpeed™ Mounting System

Installation Manual

---

[snapnrack.com](http://snapnrack.com)

SnapNrack's primary goal is to provide our customers with the lowest possible installed cost for mounting residential solar modules, without compromising the values the industry has come to expect: ease of use, quality, aesthetics, and safety. Designing with this goal in mind, we are proud to present the SnapNrack TopSpeed™ mounting system with SpeedSeal™ Technology.

SnapNrack has created a ground breaking system combining great features and benefits we are known for, with our TopSpeed™ System and the most up to date technical innovation in the industry, thus reducing parts while driving down labor, material, and total installation costs. Designed to work with standard module frames, achieving UL 2703 Listing for Grounding/Bonding and Fire Classification, providing integrated wire management, aesthetics and our industry leading "Snap-In" features, SnapNrack is providing the simplest and most cost effective solar mounting solution on the market with TopSpeed™ including integrated fasteners and SpeedSeal™ Technology.

## Advantages of Installing the SnapNrack TopSpeed™ System

**Modules are installed with a minimum number of parts**

This elimination of parts leads to a lower estimated system cost for both the installer and home owner.

**Built in Wire Management and Aesthetics**

Extensive wire management solutions have been designed specifically for the system that adapts to multiple possible mounting positions.

The system is designed to be aesthetically pleasing and sturdy with a skirt that provides considerable strength at the leading edge and an elegant look for those seeking high end looking systems.

**SnapNrack TopSpeed™ includes SpeedSeal™ Technology**

SpeedSeal™ Technology features integrated flashing. This eliminates loosening layers of composition and removing nails with a pry bar, leading to less damage to the roof, minimized potential roof leaks, and much faster installs.

**TopSpeed™ Mounts attach Directly to the Decking**

As well as all of the benefits associated with the standard SpeedSeal™ Technology, TopSpeed™ attaches to the roof sheathing and does not require rafter attachment. Simply attaching to the roof sheathing removes the requirement for finding rafters and drilling pilot holes, creating potential rafter misses that can cause leaks.

## Project Plans

Certification Details . . . . .	4
Component Details . . . . .	5
Pre-Installation Requirements . . . . .	7

## Installation Steps

TopSpeed™ Skirt Layout . . . . .	8
TopSpeed™ Mount to Module Installation . . . . .	9
TopSpeed™ Mount Skirt Installation . . . . .	10
Wire Management . . . . .	13
MLPE Attachment . . . . .	16
Module Installation . . . . .	19

## Grounding Specifications . . . . . 22

Maintaining the Grounding Bonding When Removing a Module . . . . .	23
Appendix A: List of approved Modules and MLPEs . . . . .	25



## Certification Details

---

SnapNrack TopSpeed™ mounting system has been evaluated by Underwriters Laboratories (UL) and Listed to UL Standard 2703 for Grounding/Bonding, and Fire Classification.

### **Grounding/Bonding**

Only specific components have been evaluated for bonding, and are identified as being in the ground path. The TopSpeed™ components that have been evaluated for bonding are the Mount Assembly (Mount Clamp Top, Module Clamp Tower, Angle Bracket), Clamp Assembly, Universal Skirt, Universal Skirt Clamp, Ground Lugs, and Smart Clips.

Universal Skirt Spacers, Mount Channel Nut, and Mount Base are not required to be bonded to the system based on the exceptions in clause 9.1 of UL 2703 1st Ed. Wire management clips are utilized to route conductors away from these components and must be assembled according to the instructions.

This mounting system may be used to ground and/or mount a PV module complying with UL 1703 or UL 61703 only when the specific module has been evaluated for grounding and/or mounting in compliance with the included instructions. See Appendix A for the list of modules tested for use with the TopSpeed™ System for integrated grounding.

Ground Lugs have been evaluated to both UL 467 and UL 2703 Listing requirements. The following ground lugs have been approved for use: SnapNrack model 242-92202, and IlSCO models GBL-4DBT and SGB-4.

The following components have been evaluated for bonding as the fault current ground path: TopSpeed™ Mount Assembly, (Mount Clamp Top, Module Clamp Tower, Angle Bracket), Clamp Assembly, Wire Management Clips, and Ground Lugs. In order to maintain the Listing for bonding, wire management clips must be assembled to route conductors away from parts that have not been evaluated for bonding.

A Listed (QIMS) and Unlisted Component (KDER3) grounding lug, SnapNrack part no. 242-92202, is attached to the module frame flange for the normal attachment of a Grounding Electrode Conductor, which provides bonding within the system and eventual connection to a Grounding Electrode, as required by the U.S. NEC. Details of part no. 242-92202 can be found in Volume 1, Section 4, and Volume 2, Section 2. When this method is used, the grounding symbol is stamped onto the body of the ground lug to identify the grounding terminal.

An alternate method of grounding, a UL Listed (KDER and QIMS) grounding lug, IlSCO (E34440 and E354420) model SGB-4 is attached to the module frame flange. When this method is used, the grounding terminal is identified by the green colored screws of the lug.

An alternate method of grounding, a UL Listed (KDER and QIMS) grounding lug, IlSCO (E34440 and E354420) model GBL-4BDT is attached to the module frame flange through the specified hardware and torque values. When this method is used, the grounding terminal is identified by the green colored set screw of the lug.

An alternate method of grounding, Enphase R/C (QIKH2)(QIMS2) model M250, M215 & C250 is bonded to the Listed PV module frame by the Enphase R/C (QIMS2) Model EFM-XXMM anodization piercing mounting/clamping kit. The total roof-mounted PV system is bonded (modules and microinverters) together and the assembly is bonded to ground through the Enphase R/C (QIMS2) Engage Cables; Model ETXX-240, ETXX-208 or ETXX-277, when properly grounded at the service entrance. R/C (QIMS2), Dynoraxx (E357716) photovoltaic bonding device cat. no. Dynobond is an optional component that may be used with this system. The Dynobond device has been evaluated to provide module to module bonding. The Dynobond device attaches to the frame flange of adjacent modules Listed (QIMS), SnapNrack MLPE Frame Attachment Kit model 242-02151 has been investigated to bond approved MLPE device back plates to frames of modules.

## **Fire**

SnapNrack TopSpeed™ has been investigated for a Class A System Fire Classification for Steep-Sloped and low sloped roofs with Type 1 and Type 2 modules. Because the system was tested at 5 inches above the test roof fixture, TopSpeed™ can be installed without any height restrictions due to System Fire Classification. See Appendix A for potential module-specific height restrictions due to module temperature. The Skirt is considered an optional component with respect to Fire Classification, as SnapNrack TopSpeed™ maintains the same Fire Classification Rating both with and without the skirt.

**NOTE:** Modules with an asterisk\* have a fire rating that is different from Type 1, Type 2 or Type 29. SNR systems have only been evaluated for use with Type 1, Type 2, or Type 29 modules. Modules with a different fire type rating should be considered to not have been evaluated for use with SNR systems with respect to a system fire rating.

## **Inspection Practices**

SnapNrack recommends a periodic re-inspection of the completed installation for loose components, loose fasteners, and any corrosion, such that if found, the affected components are to be immediately replaced.

## TopSpeed™ Structural Components



### TopSpeed™ Mount

SnapNrack TopSpeed™ Mount assembly including SpeedSeal™ base, clamp top, and (4) SnapNrack #14 SS Wood Screws with 1/2" Hex Head.



### TopSpeed™ Clamp

SnapNrack TopSpeed™ Clamp assembly including including Link bottom, Link top, and springs.



### Universal Skirt

SnapNrack Universal Skirt in double portrait or single landscape lengths.

## Wire Managements Components



### Skirt Spacers

SnapNrack Universal Skirt Spacer for 40mm, 38mm, 35mm, 32mm, and 30mm modules.

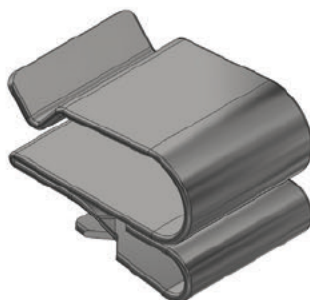

### Smart Clip

Module frame cable clip, holds two PV wires or Enphase IQ-Cables.

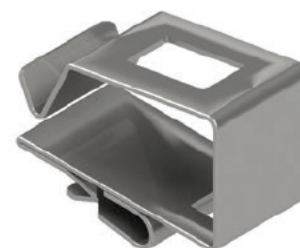

### Smart Clip XL

Module frame cable clip, holds six PV wires or four Enphase IQ-Cable.

## Grounding/MLPE Components



### Wire Saver

Designed to secure conductors that become loose and hang below the array, holds one conductor.

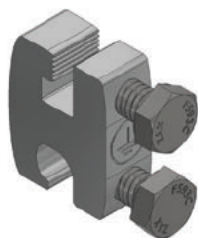

### Ground Lug

SnapNrack Ground Lug assembly used for attaching the Equipment Grounding Conductor on to one module or any TopSpeed™ Mount per array. 5

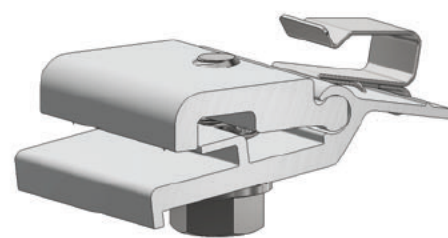

### MLPE Frame Attachment Kit

Attaches MLPEs (Module Level Performance Enhancers) and other related equipment to the module frame.

## Hardware Torque Specifications

The recommended torque to be applied to components for proper assembly and bonding are as follows:

Hardware Description	Torque Specification
All TopSpeed™ ½" bolts; System Leveling Bolt, TopSpeed™ Mount Clamping Bolt, Clamp Bolt	16 ft-lb
Ground Lug model 242-92202 to Module Frame or anywhere on the TopSpeed™ Mount, and Ground Lug model 242-92202 to Grounding Electrode Conductor (6-12 SOL)	8 ft-lb
MLPE Frame Attachment Kit, MLPE Rail Attachment Kit	10 ft-lb
SolarEdge Frame Mounted Microinverter Bracket to Module Frame	11 ft-lb
Enphase Frame Mounted Microinverter Bracket to Module Frame	13 ft-lb
Ground Lug model SGB-4 to module	75 in-lb
Ground Lug model SGB-4 to Grounding Electrode Conductor (4-14 SOL or STR)	35 in-lb
Ground Lug model GBL-4DBT to module	35 in-lb
Ground Lug model GBL-4DBT to Grounding Electrode Conductor (10-14 SOL or STR)	20 in-lb
Ground Lug model GBL-4DBT to Grounding Electrode Conductor (8 SOL or STR)	25 in-lb
Ground Lug model GBL-4DBT to Grounding Electrode Conductor (4-6 SOL or STR)	35 in-lb



## Site Survey

- Measure the roof surfaces and develop an accurate drawing, including any obstacles such as chimneys and roof vents.
- If plans for the roof structure are available, verify that the plans match the final structure.
- Identify any roof access or setback areas as required by the local AHJ.
- Identify any construction issues that may complicate the process of locating rafters from the roof surface.
- If you find structural problems such as termite damage or cracked rafters that may compromise the structure's integrity consult a structural engineer.

## Design Guidance

- PV Designers should account for the 0.75 inch spacing between rows and columns of modules when creating the layout.
- Determine site conditions for calculating the engineering values, confirm site conditions and code versions comply with local AHJ requirements.
- Reference site conditions and system specifications in TopSpeed™ Structural Engineering Report to determine the number of attachments per module side.
- Insert SnapNrack installation details into design plan set specific to the project requirements.
- Draw roof attachment locations on plan set layout based on TopSpeed™ Structural Engineering.

### Best Practice:

If environmental load conditions require three TopSpeed™ attachments per module side this is only required when modules share attachments.

- Identify homerun and Junction Box locations based on rooftop wiring requirements.
- Mark distance from array edge to identifiable roof feature in x and y axes.

### Safety Guidance

- Always wear appropriate OSHA approved safety equipment when at active construction site.
- Appropriate fall protection or prevention gear should be used. Always use extreme caution when near the edge of a roof.
- Use appropriate ladder safety equipment when accessing the roof from ground level.

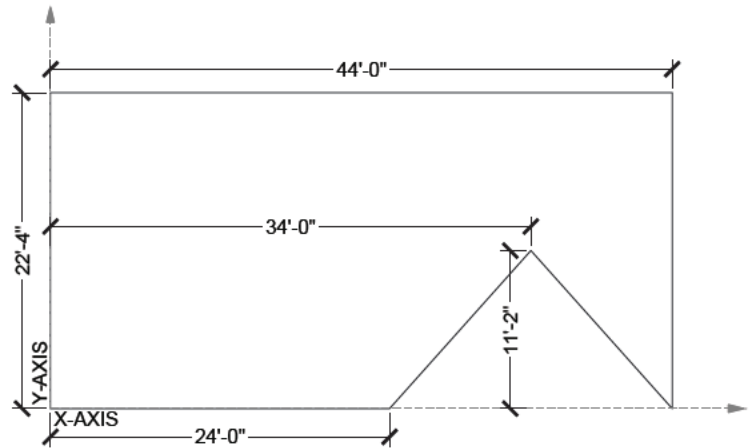

Image note: X-Axis described in this manual is cross-slope on the roof, Y-Axis is in line with the roof slope.

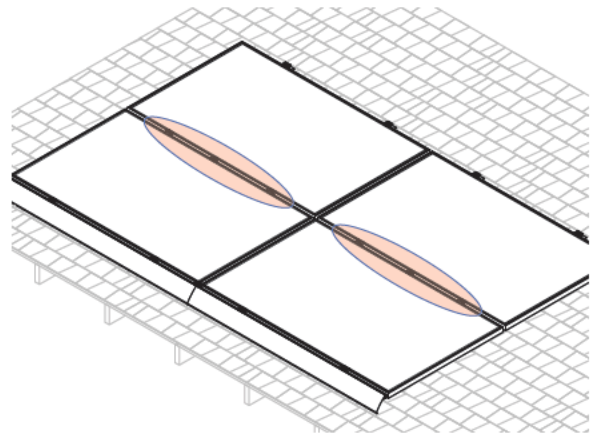
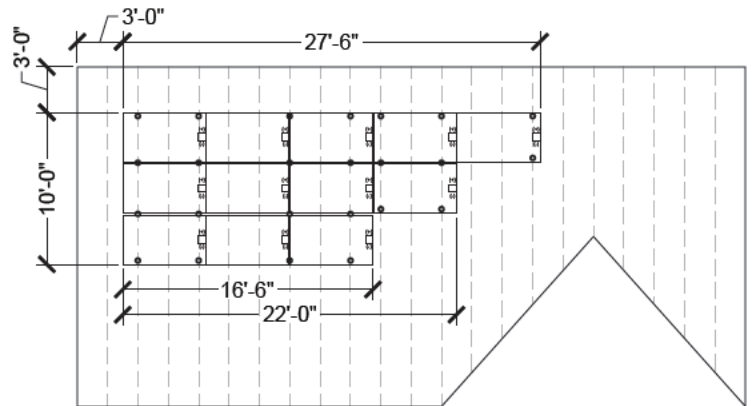

Image note: This four module array is installed in a high load configuration with three attachments per side where two modules share attachments. See highlighted area. As shown, three attachments are never required at the skirt or the top of the array.

### Safety Guidance Continued

- Safety equipment should be checked periodically for wear and quality issues.
- Always wear proper eye protection when required.

## Required Tools

● Socket Wrench/Impact Driver

● Torque Wrench

● 1/2" Socket

## Materials Included - TopSpeed™ System with SpeedSeal™ Technology

- 1 (1) SnapNrack TopSpeed™ Mount
- 2 (4) SnapNrack #14 Wood Screw with 1/2" Hex Head & sealing washer

### Best Practice:

Attach all TopSpeed™ mounts as the modules are being prepped with MLPEs on the ground. Attach Mounts before attaching MLPEs to simplify wire management.

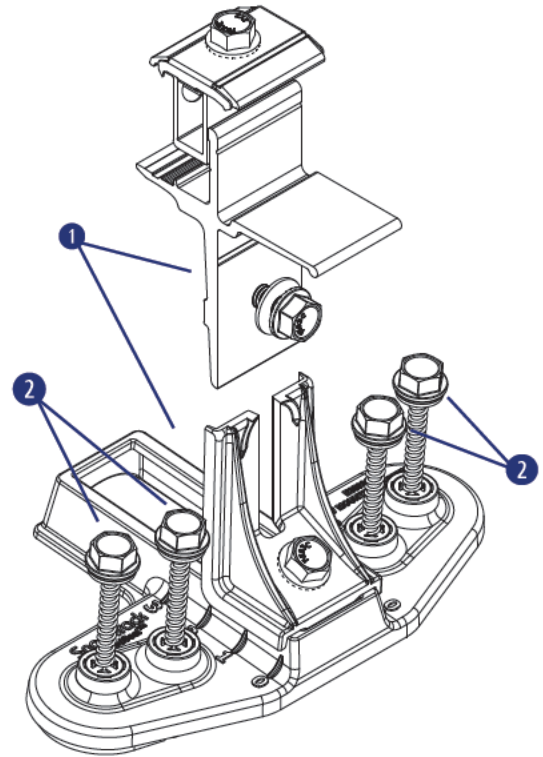

## INSTALLATION INSTRUCTIONS

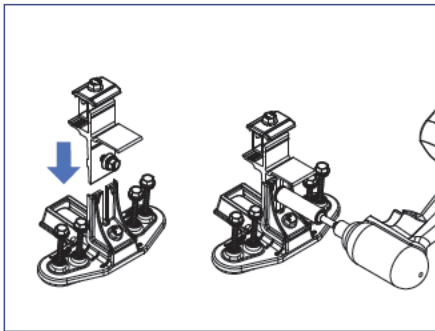

1) Assemble all TopSpeed™ Mounts required for the installation. Slide the clamp tower assembly into the angle bracket riser and tighten the leveling bolt to 16 ft-lbs.

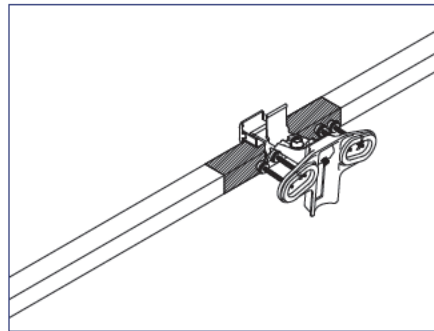

2) Position TopSpeed™ Mount clamp on the module frame within the module manufacturers required clamping zone.

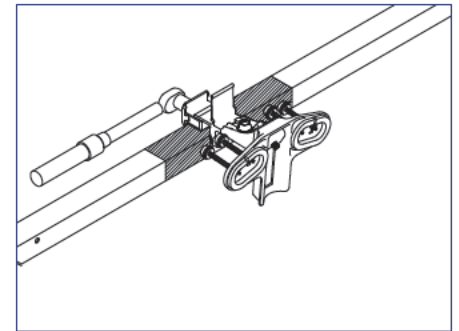

3) Tighten 1/2" clamping bolt to 16 ft-lb. Only two Mounts are required per module on one side.

### Install Note:

For high load conditions add a third attachment in the middle of the module frame.

## Required Tools

- Roof Marking Crayon or Chalk
- Tape Measure

## LAYOUT INSTRUCTIONS

1) Use a tape measure to verify that all modules will fit properly on the roof surface.

2) On the roof draw the layout for the skirt installation including module gaps (recommended 0.75 inch gap), bottom corners, and locations of the two TopSpeed™ attachments per module that clamp to the skirt. Three attachments per module is never required at the skirt.

### Install Note:

If environmental load conditions require three TopSpeed™ attachments per module side this is only required when modules share attachments.

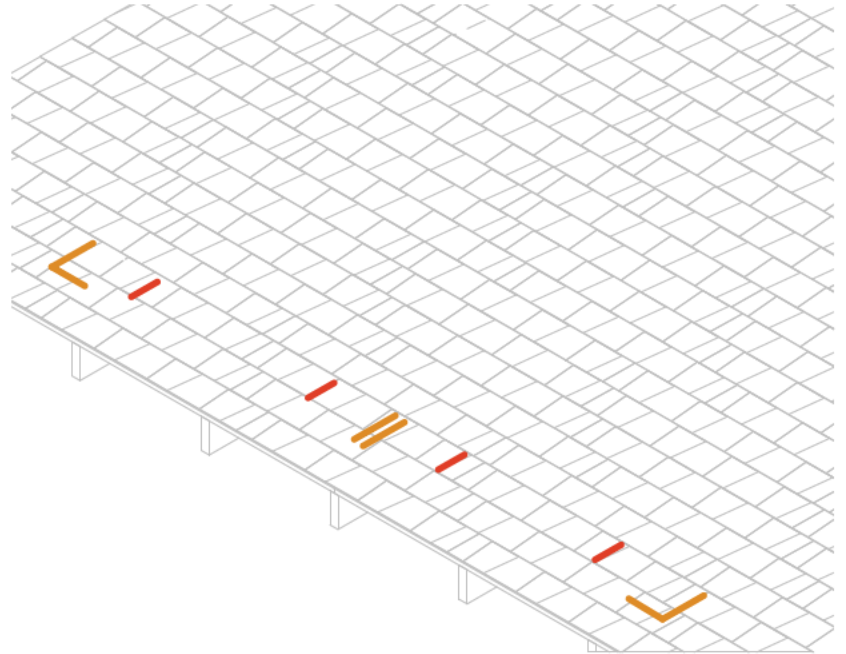

# TopSpeed™ Mount: Skirt Installation

## Required Tools

- Socket Wrench/Impact Driver
- Torque Wrench
- 1/2" Socket
- Roofing sealant

## Materials Included - TopSpeed™ Mount with SpeedSeal™ Technology

- ① (1) TopSpeed™ Mount
- ② (1) TopSpeed™ Clamp
- ③ (1) Universal Skirt
- ④ (1) Universal Skirt Spacers
- ⑤ (1) *OPTIONAL* - Universal Link

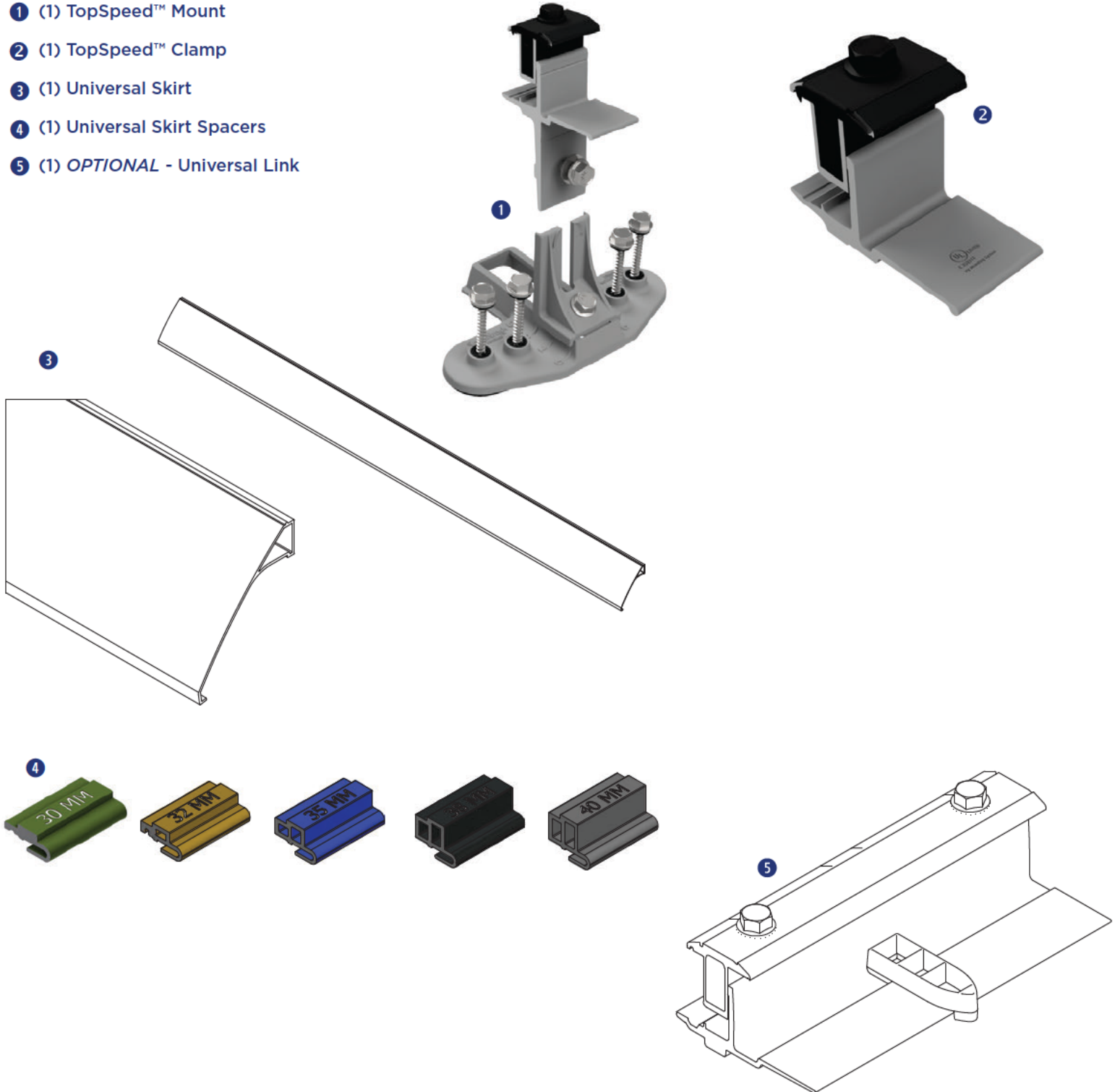



## INSTALLATION INSTRUCTIONS

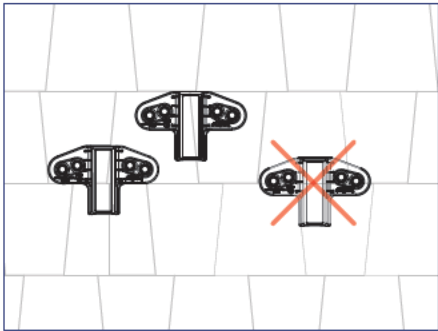

1) Install TopSpeed™ Mounts at locations drawn during the skirt layout. Mounts must be installed entirely on one course of composition.

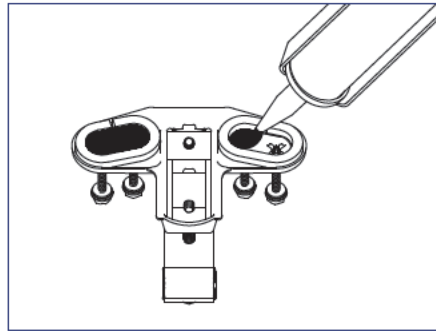

2) Fill both cavities on bottom of TopSpeed™ Mount created by SpeedSeal™ gasket with roof sealant to ensure a watertight seal.

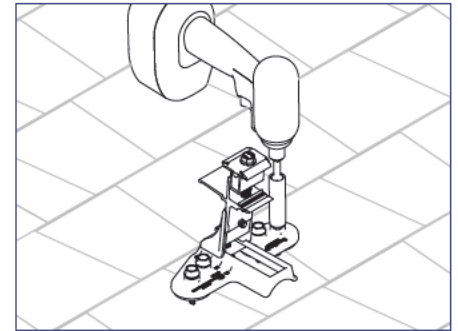

3) Attach TopSpeed™ Mount to roof using the (4) SnapNrack #14 Wood Screws with 1/2" hex head that are captured in the Mount.

### Install Note:

Roof sealant should be expelled from both vents of the TopSpeed™ Mount as it is installed to assure the proper amount of roof sealant has been applied. If sealant is not expelled from all four vents, remove TopSpeed™ Mount, add more sealant to the cavity, then reinstall.

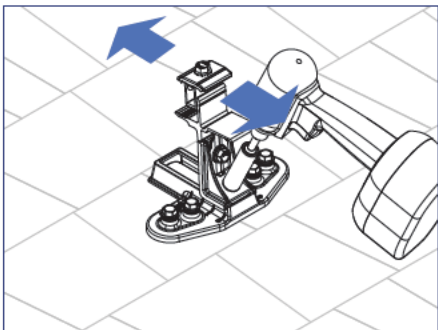

4) Loosen Course Adjustment bolt and adjust end Mounts up or down until aligned with bottom edge of array as marked on the roof, then tighten the Course Adjustment bolt.

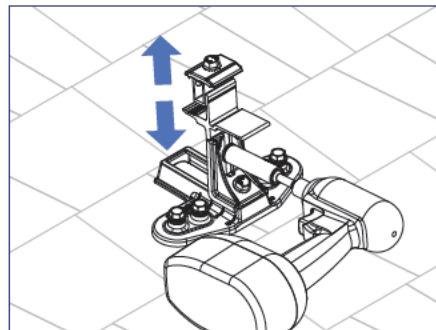

5) To set the TopSpeed™ Mount level loosen the Leveling bolt and move the clamp up or down, then tighten the Leveling bolt and torque to 16 ft-lb.

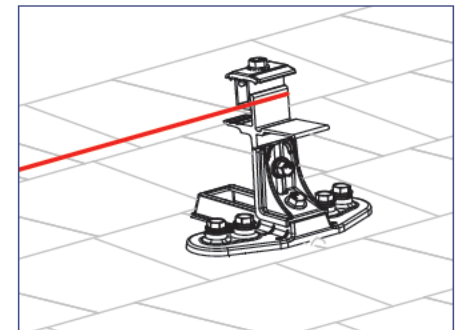

6) Pull string line tight from one corner mount to opposite corner mount to align and level all TopSpeed™ Mounts between the end mounts.

### Install Note:

Use the string line alignment feature on Mounts to level and align the Mounts.

## INSTALLATION INSTRUCTIONS

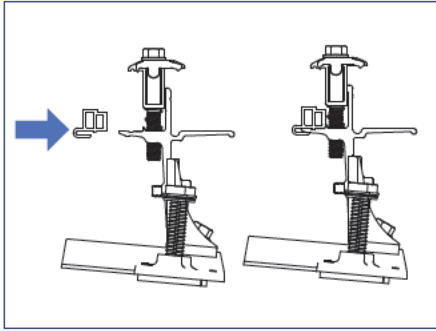

7) Universal Spacers will need to be added to Mounts and Clamps where Skirt will be installed.

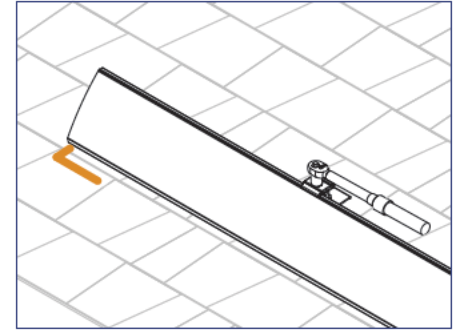
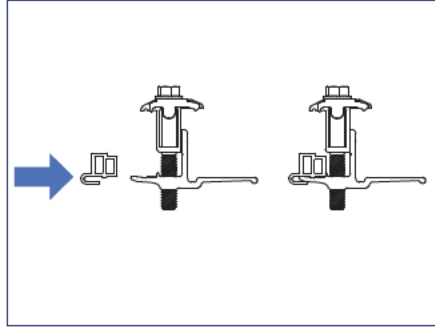

8) Install Universal Skirt by holding the skirt in Mount, sliding Skirt to align with array layout marks, and clamping skirt into mount.

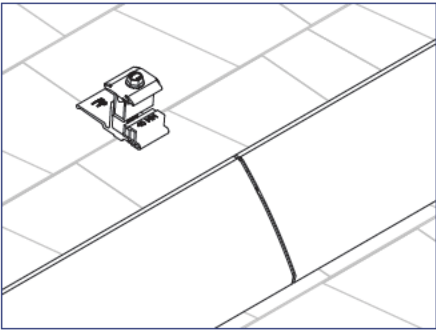

9) Use TopSpeed™ Clamps to connect multiple lengths of Array Skirt.

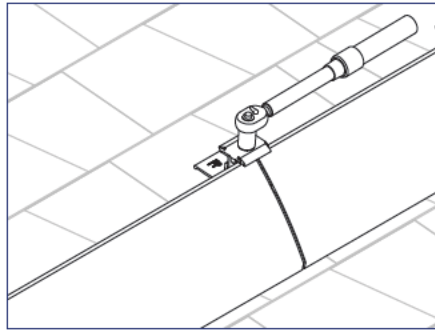

### Install Note:

Optionally use Universal Links to connect lengths of Array Skirt.

## Required Tools

- Socket Wrench
- Torque Wrench
- 1/2" Socket
- Electrician Tools

## Materials Included

### Smart Clips

- 1 (1) Smart Clip [(2) PV Wire, (1) Enphase IQ Cable]
- 2 (1) Smart Clip XL [(6) PV Wire, (4) Enphase IQ]
- 3 (1) Wire Saver [(1) PV Wire]

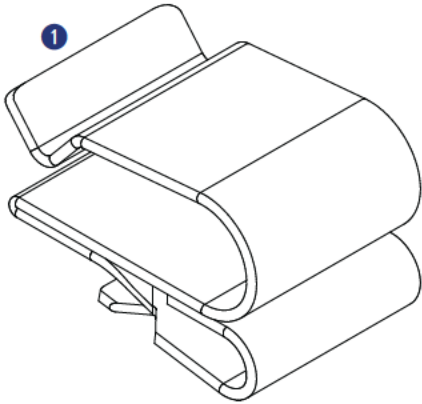

Smart Clip

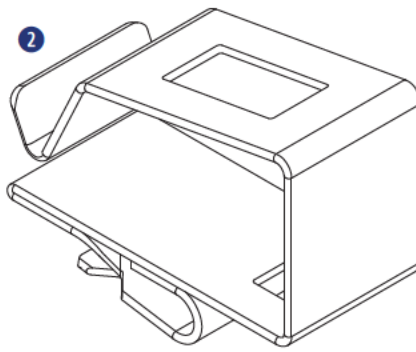

Smart Clip XL

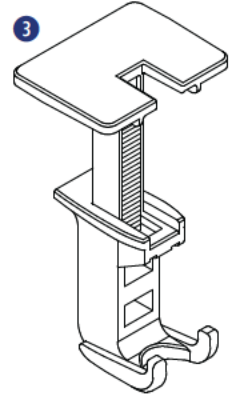

Wire Saver

## INSTALLATION INSTRUCTIONS - GROUND LUG

The SnapNrack Ground Lug to be used in accordance with the National Electric Code, ANSI/NFPA 70.

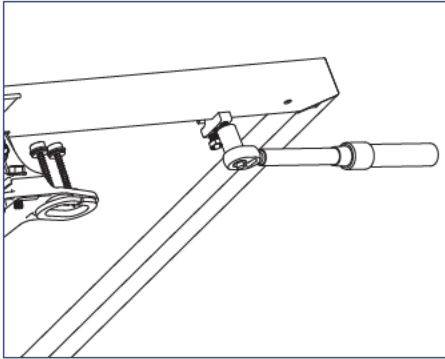

1) Ground Lug (242-92202) can be attached anywhere along the module frame or any TopSpeed™ Mount near the Junction Box. Torque module clamping bolt to 8 ft-lb.

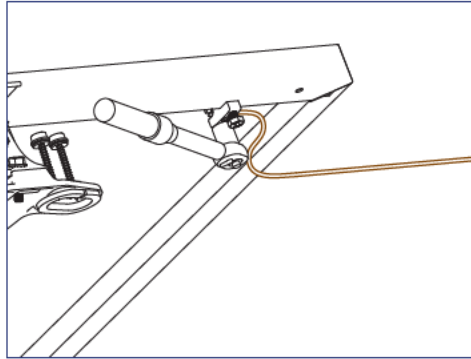

2) Run 10 - 6 AWG, solid, bare copper GEC into Ground Lug channel, torque wire clamping bolt to 8 ft-lb.

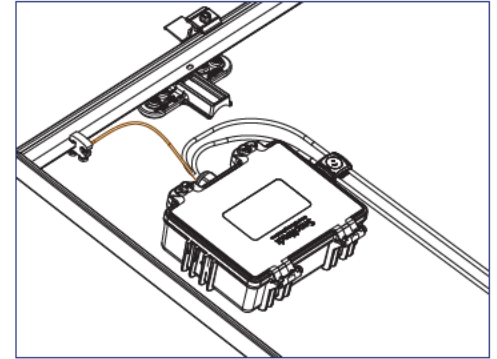

3) Run bare, solid EGC from Ground Lug R to Junction Box, bond bare EGC to stranded EGC in Junction Box. For details on installing the Junction Box reference the **Junction Box Installation Manual**.

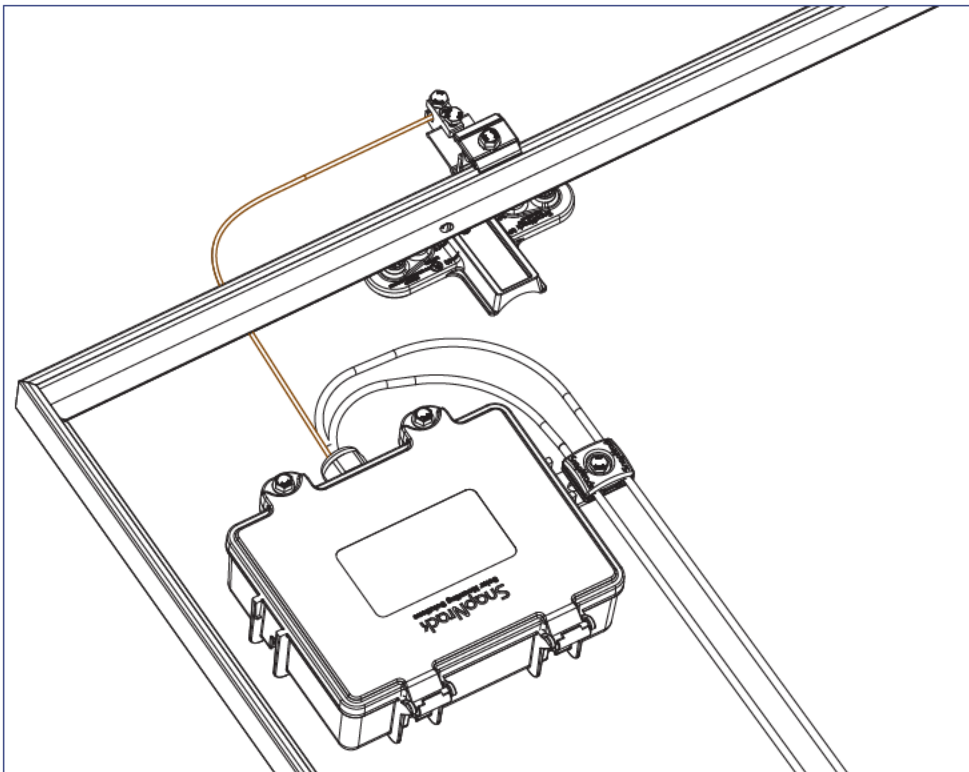

4) Optionally; Install Ground Lug on the Mount Landing Pad at the top of the array. Run bare copper between ground lug and Junction Box.



## INSTALLATION INSTRUCTIONS - SMART CLIPS

SmartClip and SmartClip XL should be used to route conductors in a neat and workmanlike manner away from all non-bonded components and support the conductors adequately to eliminate potential damage.

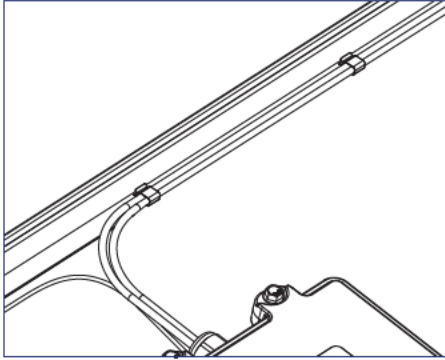

1) Use SnapNrack Smart Clip II to manage up to two PV wires inside the module frame while prepping out the modules on the ground or installing modules on the roof.

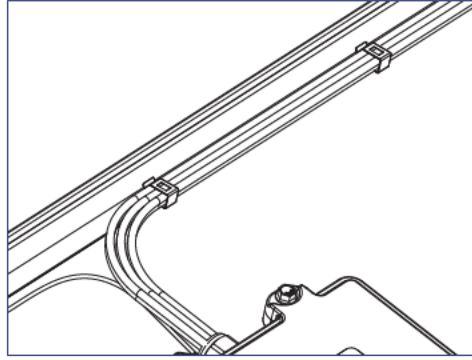

2) Use SnapNrack Smart Clip XL to manage larger bundles of PV wire; up to 6 PV wires per clip

## Required Tools

- Socket Wrench
- Torque Wrench
- 1/2" Socket

## Materials Included - MLPE Rail Attachment Kit

- 1 (1) SnapNrack MLPE Frame Attachment Top
- 2 (1) SnapNrack MLPE Frame Attachment Bottom
- 3 (1) 5/16"-18 X 3/4" Serrated Flange Bolt SS
- 4 (1) SnapNrack Smart Clip
- 5 (1) SnapNrack MLPE Frame Attachment Coil Spring SS

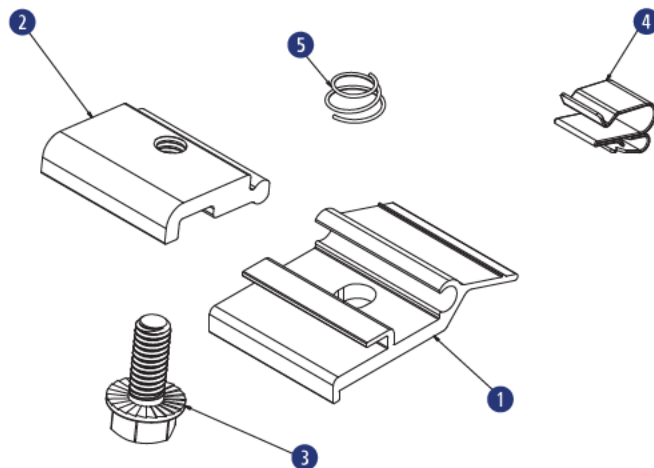
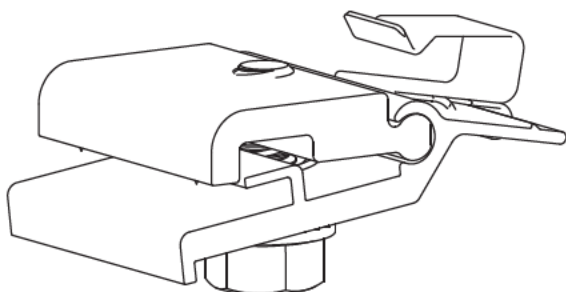

## Materials Included

### SolarEdge Frame Mount

- 1 (1) SolarEdge Optimizer w/ Frame-Mounted Module Add-On

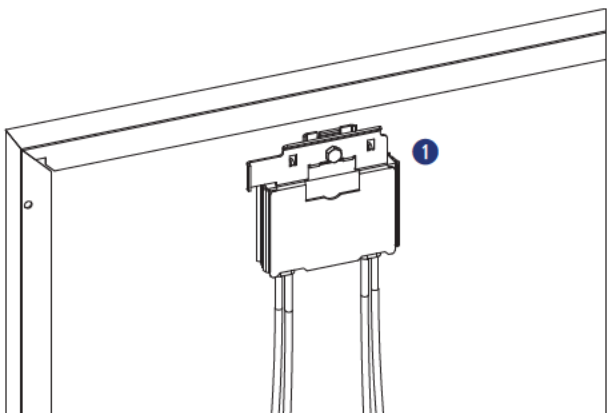

### Enphase Frame Mount

- 1 (1) Enphase Microinverter
- 2 (1) Enphase Frame Mount

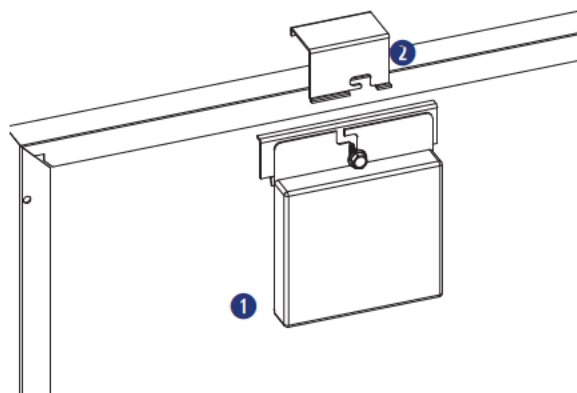

## INSTALLATION INSTRUCTIONS - SNAPRACK MLPE FRAME ATTACHMENT KIT

SnapNrack MLPE Frame Attachment kit are used to attach module level performance enhancing devices, and other devices such as an SRD (rapid shutdown device), directly to module frames, and provide integrated grounding/bonding for Devices grounded through metal back plate. (Refer to the list of tested MLPE devices on page XX of this manual).

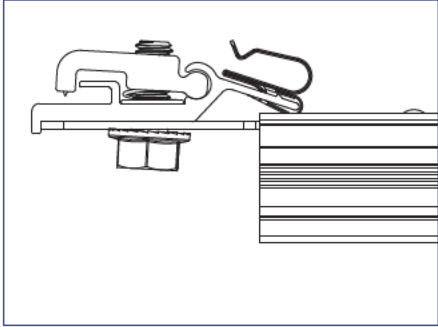

1) Slide the backplate channel of the MLPE device under the MLPE Frame Attachment Kit bolt. The MLPE mounting plate should rest against the MLPE mounting plate backstop on the MLPE Frame Attachment Kit.

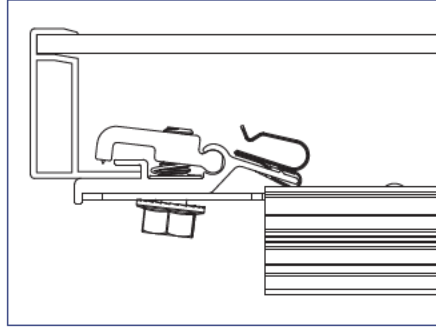

2) Position the MLPE Frame Attachment Kit on the module frame flange in a location that will not interfere with mounting system components. The module frame flange should rest against the module flange backstop on the MLPE Frame Attachment Kit.

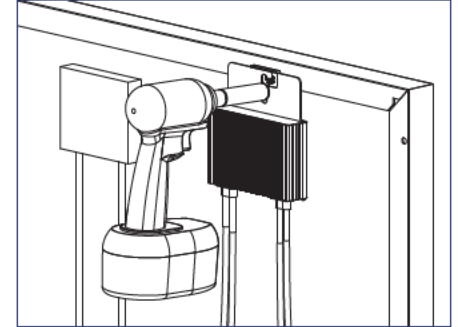

3) Tighten the mounting bolt on the MLPE Frame Attachment Kit to 12 lb-ft (144 lb-in).



### Install Note:

The MLPE Frame Attachment Kit bonds the following components:  
Module Frame, MLPE backplate and Smart Clip.



### Install Note:

Avoid blocking module frame drainage holes when installing the MLPE Frame Attachment Kit.

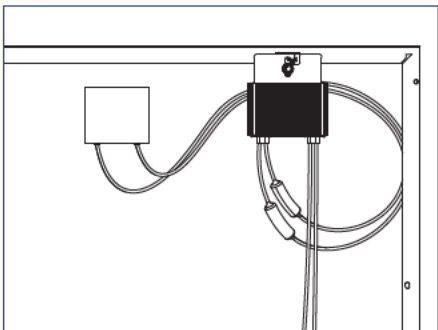

4) Connect the module leads to the input connectors on the MLPE device and manage conductors with the integrated Smart Clip.

## INSTALLATION INSTRUCTIONS - SOLAREGE FRAME MOUNT

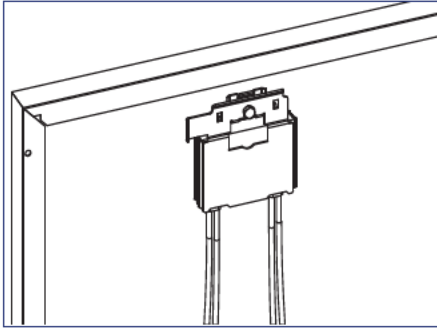

1) Locate the SolarEdge optimizer with Frame-Mounted Module Add-On at a location on the module frame that will not interfere with the TopSpeed™ Mounts.

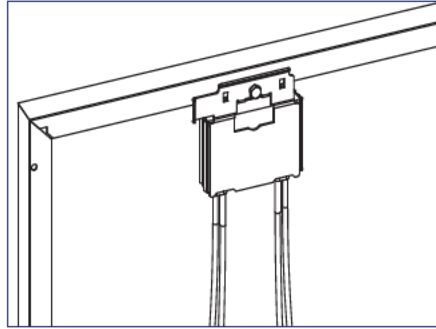

2) Install the optimizer mounting plate onto the module frame and tighten hardware to 11 ft-lbs.

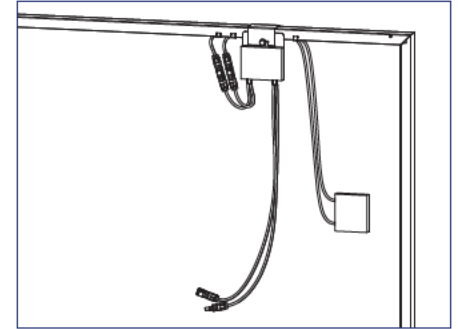

3) Connect the module leads to the input connectors on the optimizer and manage conductors with SnapNrack Smart Clips.



### Install Note:

If module is mounted in portrait, install MLPE on long side, short side for landscape.

## INSTALLATION INSTRUCTIONS - ENPHASE FRAME MOUNT

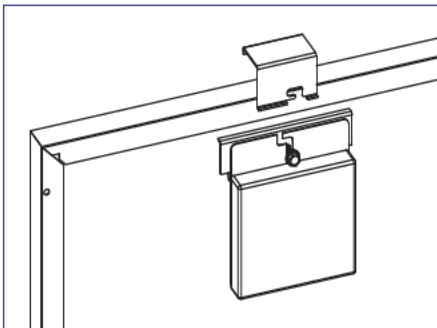

1) Locate the Enphase Frame Mount bracket clamp at a location on the module frame that will not interfere with the TopSpeed™ Mounts.

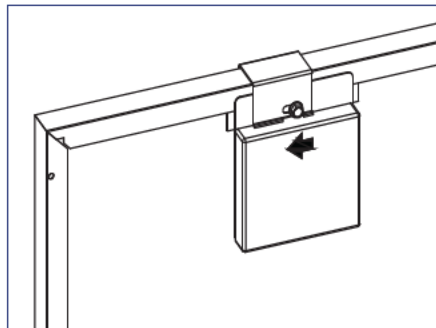

2) Slide the microinverter unit onto the bracket clamp, then move it slightly to the left.



### Install Note:

The microinverter mounting flange should be on the outside of the module frame.

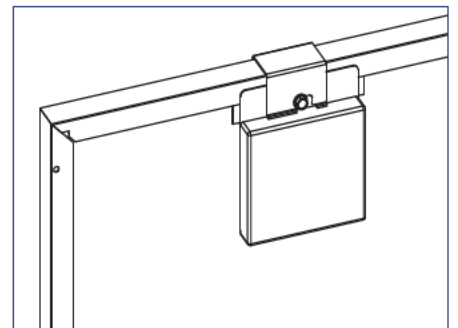

3) Tighten the hardware to 13 ft-lbs.

4) Connect module leads to microinverter DC connectors.



### Install Note:

Refer to the Enphase Frame Mount installation guide for additional instructions.



## Required Tools

- Socket Wrench
- Torque Wrench
- 1/2" Socket
- Roofing Sealant

## Materials Included

- ① SnapNrack TopSpeed™ Mount
- ② SnapNrack TopSpeed™ Clamp

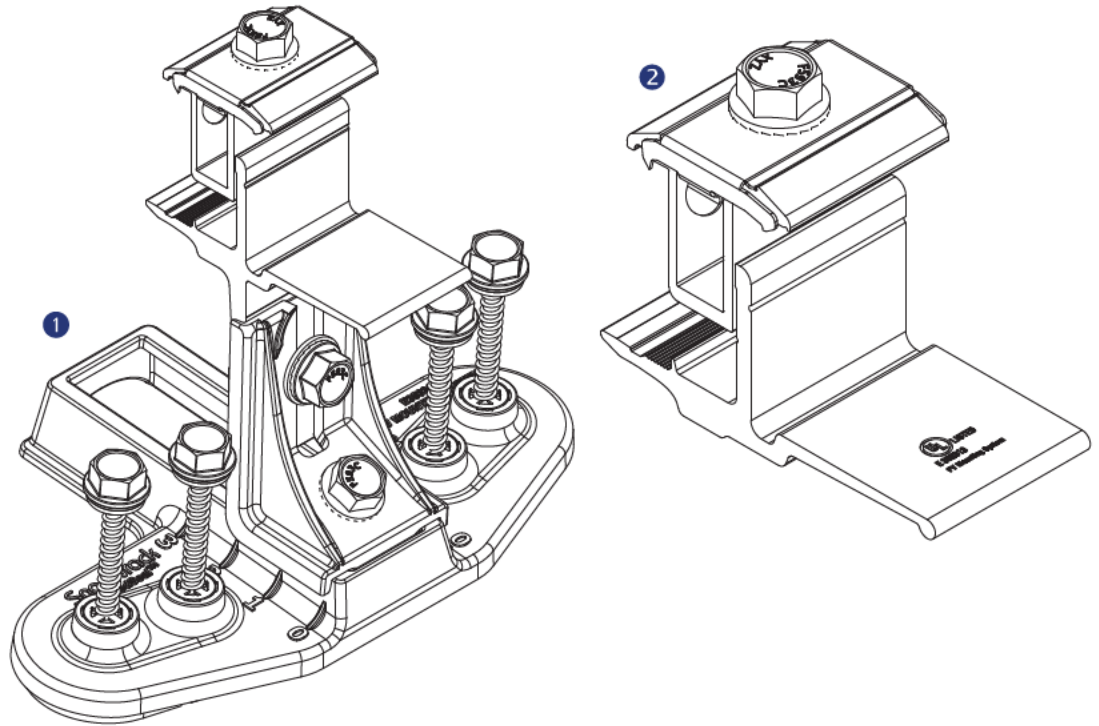

## Other Materials Required

- ② SnapNrack Smart Clip (2-5 per module)  
*See Wire Management section for details*
- ③ SnapNrack Smart Clip XL (10-20 per array)  
*See Wire Management section for details*

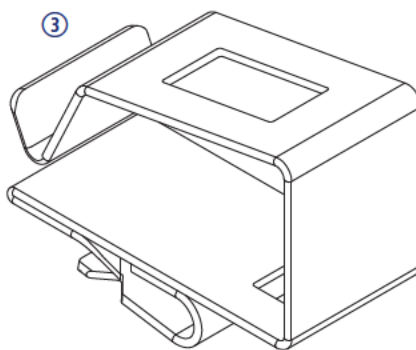
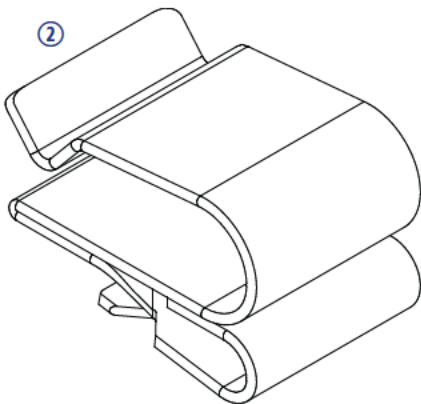

## INSTALLATION INSTRUCTIONS - BOTTOM ROW

### Recommended Best Practice:

Attach all TopSpeed™ mounts as the modules are being prepped with MLPEs on the ground. Attach Mounts before attaching MLPEs to simplify wire management.

### Install Note:

It is recommended that module leads and connectors are prepared for installation using SnapNrack Smart Clips before being brought to the rooftop.

- With no MLPE, secure module leads to module frame to allow access to connectors while modules are installed
- Secure MLPE device to module frame with SnapNrack MLPE Frame Attachment Kit and connect module leads to MLPE, and manage leads by positioning connectors to allow access during installation

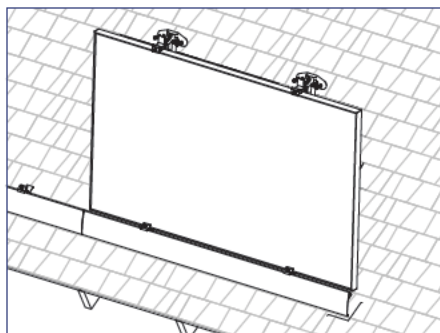

1) Rest downslope edge of module on the Mounts and/or Clamps position module so side edge is flush with marked edge of array layout or Skirt.

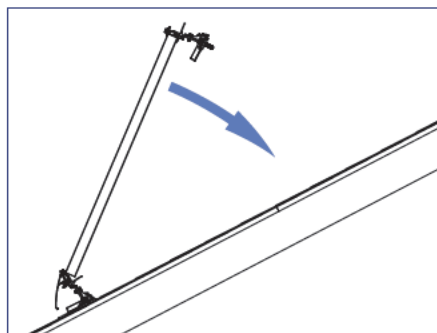

2) Lower upslope edge of module while simultaneously applying slight pressure to seat module into Mounts and/or Clamps.

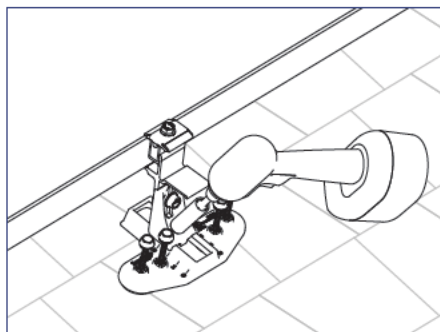

3) When module is level with roof verify the Speedseal™ portion of the TopSpeed™ Mounts are positioned entirely on one course of composition. If required listen the 1/2" nut and adjust the base as needed then tighten the bolt.

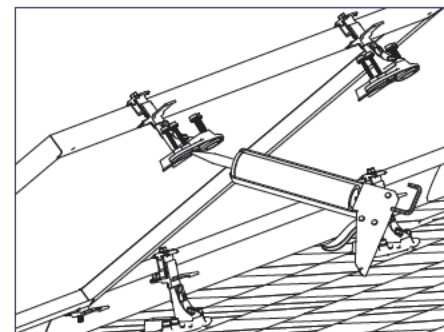
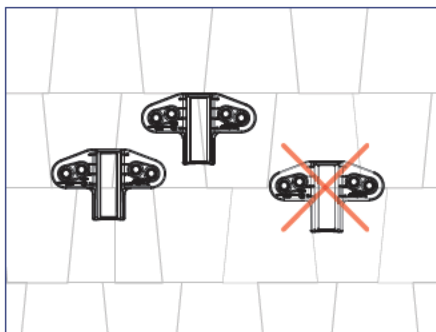

4) Lift the upslope edge of the module and fill the SpeedSeal™ reservoir with roofing sealant.

### Install Note:

Roof sealant should be expelled from both vents of the TopSpeed™ Mount as it is installed to assure the proper amount of roof sealant has been applied. If sealant is not expelled from all four vents, remove TopSpeed™ Mount, add more sealant to the cavity, then reinstall.

## INSTALLATION INSTRUCTIONS - BOTTOM ROW

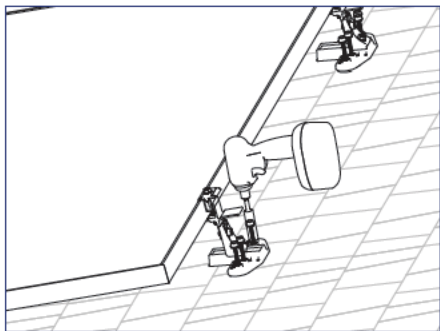

5) Lower the module to the roof and drive the (4) pre installed Snapnrack #14 Wood Screws with 1/2" hex head into the roof sheathing.

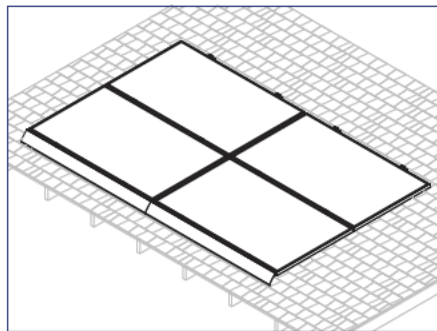

6) Repeat steps 1 through 5 for additional modules in the array.

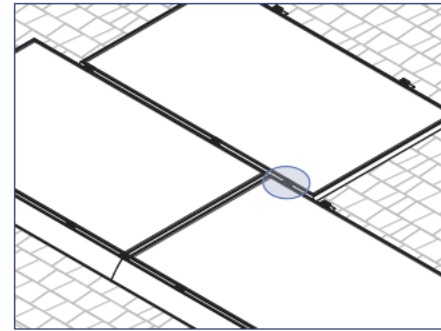

7) For staggered arrays and arrays with mixed orientation, use the TopSpeed™ Clamp as needed to support the modules.

### Install Note:

Roof sealant should be expelled from both vents of the TopSpeed™ Mount as it is installed to assure the proper amount of roof sealant has been applied. If sealant is not expelled from both vents, remove TopSpeed™ Mount, add more sealant to the cavity, then reinstall.

When installing a TopSpeed™ Clamp for support of an over cantilevered module, the clamp shall be installed 2-6" from the edge of the upslope (cantilevered) module.

## GROUND PATH DETAILS

All TopSpeed™ components in the fault current ground path have been Certified to be used multiple times for grounding/bonding. The UL 2703 Listing does not specify a maximum number of uses for the Mount, Link, or Ground Lug. Review the requirements of the National Electrical Code (NEC) Article 250 to select the appropriate Equipment Grounding Conductor size based on the short-circuit current of the PV system.

When using Ground Lug R the following components are part of the fault current ground path:

- SnapNrack, TopSpeed™ Mount
- SnapNrack, TopSpeed™ Clamp

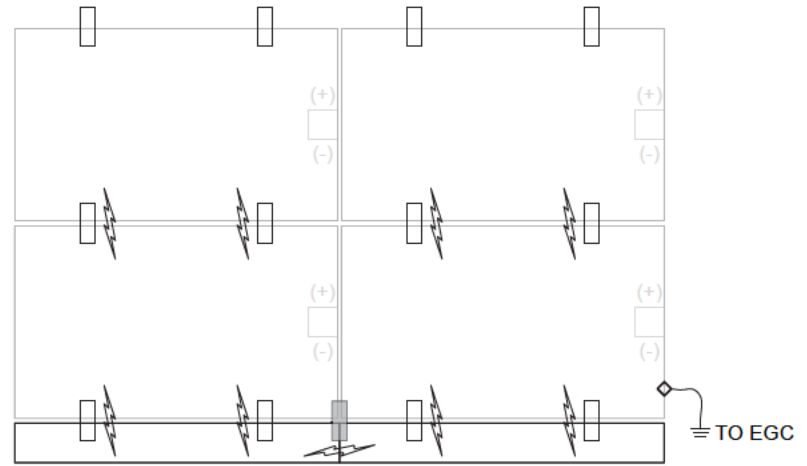

## GROUNDING METHOD DETAILS

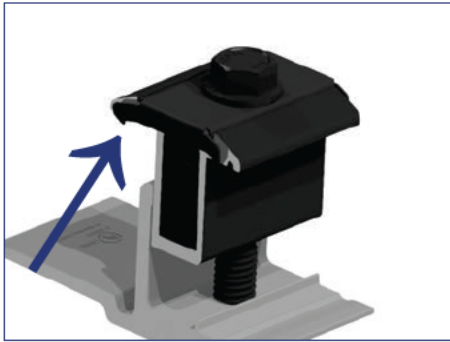

1) Row to row module bonding provided by bonding clips in Mount assembly and Clamp assembly.

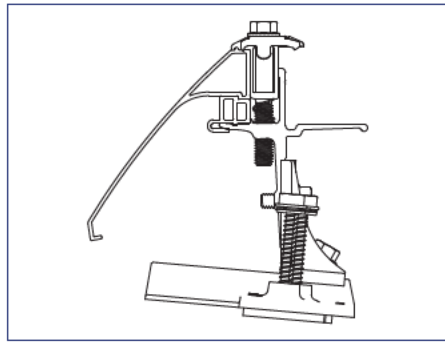

2) Column to column bonding provided by Universal Skirt and bonding clips in the Clamp assembly and/or the RL Universal Link assembly. Module heights evaluated for bonding with Link Bonding Clamps: 40mm, 38mm, 35mm, 32mm, 30mm

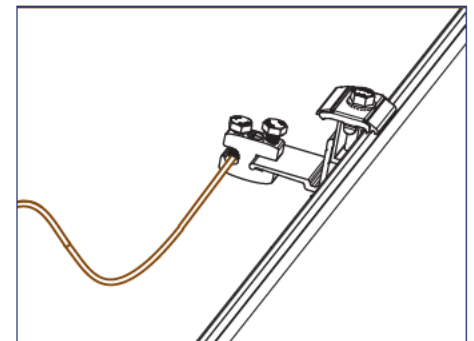
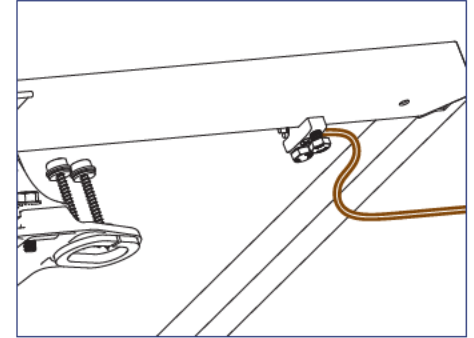

3) Each continuous array is connected to Equipment Grounding Conductor through Ground Lug (242-92202) installed on one module per array.

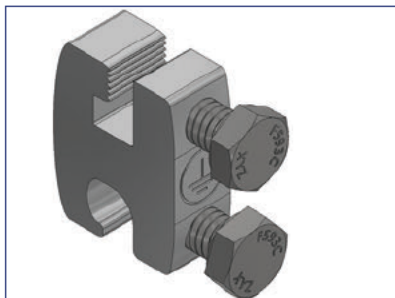

## GROUNDING MARKING DETAILS

The Ground Lug is marked with the ground symbol.

Optionally; Install Ground Lug on the Mount Landing Pad at the top of the array.



## INSTRUCTION FOR MAINTAINING THE GROUNDING BONDING WHEN REMOVING A MODULE FOR SERVICING

**CAUTION:** Module removal may disrupt the bonding path and could introduce the risk of electric shock. Additional steps may be required to maintain the bonding path. Modules should only be removed by qualified persons in compliance with the instructions in this manual.

Module removal is not presented as a frequently expected occurrence and will not be required as part of routine maintenance.

Scenarios that could result in a disruption of the bonding path are described, for example irregularly-shaped arrays, arrays consisting of individual rows, and any other scenario where module removal could disrupt the bonding path. In most cases, the removal of a module for servicing will not disturb or break grounding continuity. If a module is to be removed that will break continuity, these are the steps that must be taken to maintain a continuously bonded SnapNrack TopSpeed™ System.

### Required Tools

- Socket Wrench
- Torque Wrench
- 1/2" Socket
- 7/16" Socket

### Required Materials

- 1 #10 Or Larger Bare Copper Conductor
- 2 SnapNrack Ground Lug part no. 242-92202
- 3 IlSCO Part No. SGB-4
- 4 DnoRaxx Dynobond™

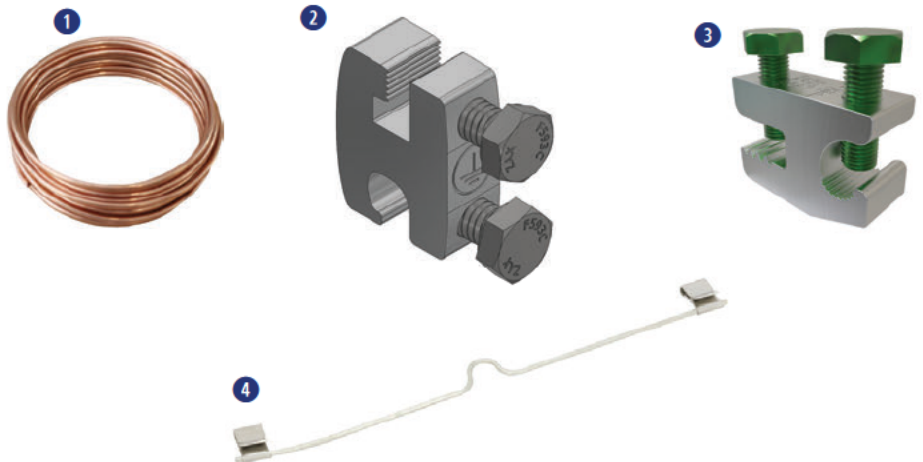

# Maintaining the Grounding Bonding When Removing a Module

## JUMPER ASSEMBLY INSTRUCTION & INSTALLATION

**CAUTION:** Do Not Remove the Module until the Jumper is installed

1) Identify the existing ground path at the location of module removal and choose an appropriate length of #10 bare copper to bridge the soon to be broken ground path.

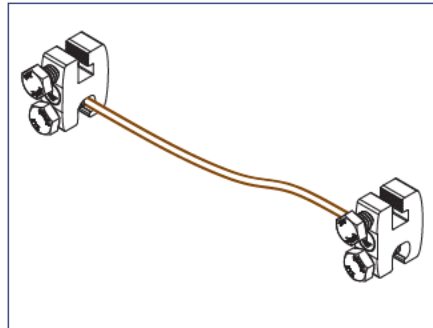

*Example of assembled bonding jumper using (2) SnapNrack Ground Lugs*

2) Attach one ground lug to each end of #10 bare copper wire. See recommended options below:

1. (2) SnapNrack Ground Lug part no. 242-922022
2. (2) IlSCO part no. SGB-4
3. (1) DroRaxx DynoBond™

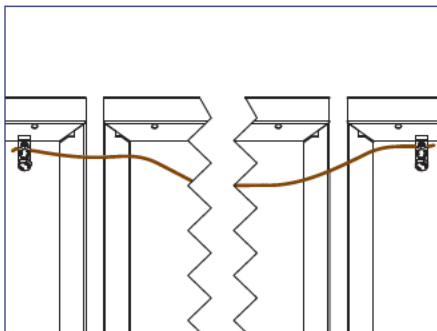

3) Before the module is removed, attach the assembled bonding jumper. Depending on where the module will be removed and choice of ground lug, jumper attachment locations will vary.

- SnapNrack Ground Lug part no. 242-92202 or IlSCO SGB-4 lugs can be attached to module frames or anywhere on the TopSpeed™ Mount.
- DynoRaxx DynoBond™ is approved and appropriate when a short bonding jumper is needed from module to module.

4) Service the array. With the bonding jumper installed, it is now safe to remove the module for service or maintenance.

5) After Servicing the array reinstall the module and original ground path. Only then Remove the bonding jumper.

**Caution:** Do not remove the bonding jumper until original ground path is established.

## APPROVED MODULE & MLPE INFORMATION

SnapNrack TopSpeed™ System has been tested with the following UL Listed module series: The SnapNrack TopSpeed™ System employs top-down clamps and links which have been evaluated for frame-to-system bonding, at specific mounting torques and with the specific module series listed below. All wattage values are covered.

Module manufacturer approval letters can be found at [www.snaprack.com](http://www.snaprack.com).

Manufacturer	Model	
Aptos Solar	DNA-120-MF23-XXX	DNA-120-BF26-XXXW
	DNA-120-BF23-XXX	DNA-144-BF26-XXXW
	DNA-144-MF23-XXX	DNA-108-BF10-xxxW
	DNA-144-BF23-XXX	DNA-120-BF10-xxxW
	DNA-120-MF26-XXXW	DNA-108-MF10-xxxW
	DNA-144-MF26-XXXW	
Canadian Solar	CS6K-XXX-M	CS1H-XXX-MS
	CS6K-XXX-M-SD	CS1H-XXX-MS-AB
	CS6K-XXX-P	CS3W-XXX-P
	CS6K-XXX-P-SD	CS3N-XXX-MS
	CS6K-XXX-MS	CS1Y-XXX-MS
	CS3K-XXX-P	CS3W-MB-AG
	CS3K-XXX-MS	CS3Y-MB-AG
	CS3U-XXX-MS	CS6W-XXXMB-AG
	CS3U-XXX-P	CS6R-XXXMS-HL
	CS1K-XXX-MS	CS3W-XXX-MS
CertainTeed	CTXXXHC11-06	
Chint Solar	CHSM6612M-XXX	CHSM72M-HC-XXX* (Astro 4)
	CHSM6612M(BL)-XXX	CHSM72M-HC-XXX* (Astro 5)
	CHSM6612M/HV-XXX	
Dehui Solar	DH-M760B-XXXW	DH-M760F-XXXW
	DH-M760W-XXXW	DH-M772F-XXXW
	DH-M772W-XXXW	
Freedom Forever	FF-MP-BBB-xxx	
Hanwha Q Cells	Q.PEAK DUO-G5-XXX	Q.PEAK DUO XL-G10.3/BFG-XXX
	Q.PEAK DUO-BLK-G5-XXX	Q.PEAK DUO G10-XXX
	Q.PLUS DUO-G5-XXX	Q.PEAK DUO BLK G10-XXX
	Q.PEAK DUO-G7-XXX	Q.PEAK DUO G10+-XXX
	Q.PEAK DUO-BLK-G7-XXX	Q.PEAK DUO BLK G10+-XXX
	Q.PEAK DUO-G7.2-XXX	Q.PEAK DUO XL-G10.3-XXX
	Q.PEAK DUO-G6+-XXX	Q.PEAK DUO XL-G10.c-XXX
	Q.PEAK DUO-BLK-G6+-XXX	Q.PEAK DUO XL-G10.d-XXX
	Q.PEAK DUO-G6-XXX	Q.PEAK DUO L-G8.3/BFG-XXX
	Q.PEAK DUO-BLK-G6-XXX	Q.PEAK DUO L-G8.3/BGT-XXX
	Q.PEAK DUO-G8+-XXX	Q.PEAK DUO ML-G10-XXX
	Q.PEAK DUO-BLK-G8+-XXX	Q.PEAK DUO BLK ML-G10+-XXX

Manufacturer	Model	
Hanwha Q Cells	Q.PEAK DUO-G8-XXX	Q.PEAK DUO ML-G10+-XXX
	Q.PEAK DUO-BLK-G8-XXX	Q.PEAK DUO BLK ML-G10-XXX
	Q.PEAK DUO BLK-G6+/AC-XXX	Q.PEAK DUO ML-G10.a+-XXX
	Q.PEAK DUO-ML-G9-XXX	Q.PEAK DUO BLK ML-G10.a+-XXX
	Q.PEAK DUO-BLK-ML-G9-XXX	Q.PEAK DUO ML-G10.a-XXX
	Q.PEAK DUO-BLK-G9-XXX	Q.PEAK DUO BLK ML-G10.a-XXX
	Q.PEAK DUO-BLK-ML-G9+-XXX	Q.PEAK DUO BLK G10+/AC XXX
	Q.PEAK DUO-ML-G9+-XXX	Q.PEAK DUO BLK G10+/HL XXX
	Q.PEAK DUO-BLK-ML-G9+-XXX	Q.PEAK DUO XL-G11.3 XXX
	Q.PEAK DUO XL-G9.2-XXX	Q.PEAK DUO XL-G11.3 BFG XXX
	Q.PEAK DUO XL-G9.3-XXX	Q.TRON-G1+ XXX
	Q.PEAK DUO XL-G9.3/BFG-XXX	Q.TRON BLK-G1+ XXX
	Q.PEAK DUO XL-G10.2-XXX	
HT-SAAE	HT60-166M-XXX	HT60-182M-XXX
Heliene	60M-XXX	72M-XXX
	60P-XXX	72P-XXX
"Hyundai (All may be followed by "BK")"	HiA-SXXXMS	HiS-SXXXVI
	HiS-SXXXXY	HiS-SXXXVH(BK)
Hyperion/Runergy	HY-DH108P8-XXX(Y)	
JA Solar	JAM60S09-XXX/PR	JAM72S10-XXX/PR
	JAM60S10-XXX/MR	JAM72S12-XXX/PR
	JAM60S10-XXX/PR	JAM60S17-XXX/MR
	JAM60S12-XXX/PR	JAM54S30-XXX/MR
	JAM72S09-XXX/PR	JAM54S31-XXX/MR
	JAM72S10-XXX/MR	JAM72D30-XXX/MB
Jinko Solar	JKMXXXM-60	JKMXXXP-72-V
	JKMXXXM-60L	JKMXXXPP-72
	JKMXXXM-60HL	JKMXXXPP-72-V
	JKMXXXM-60HBL	JKMSXXXP-72
	JKMXXXP-60	JKMXXXM-72HL-V
	JKMXXXP-60-J4	JKMXXXM-72HL-TV
	JKMXXXP-60-V	JKMXXXM-72HBL
	JKMXXXP-60B-J4	JKMXXXM-6TL3-B
	JKMXXXPP-60	JKMXXXM-6RL3-B
	JKMXXXPP-60-V	JKMXXXM-7RL3-V
	JKMXXXM-72	JKMXXXM-7RL3-TV
	JKMXXXM-72L-V	JKMXXXM-72HL4-V
	JKMXXXP-72	JKMXXXM-72HL4-TV
LG	LGXXXN1C-A5	LGXXXA1C-V5
	LGXXXN1K-A5	LGXXXM1C-L5
	LGXXXQ1C-A5	LGXXXM1K-L5
	LGXXXQ1K-A5	LGXXXN1C-N5
	LGXXXS1C-A5	LGXXXN1K-L5
	LGXXXN2C-B3	LGXXXN1K-A6
	LGXXXN2W-B3	LGXXXN1C-A6



Manufacturer	Model	
LG	LGXXXN1C-G4	LGXXXN1W-A6
	LGXXXN1K-G4	LGXXXQ1C-A6
	LGXXXS1C-G4	LGXXXQ1K-A6
	LGXXXN2C-G4	LGXXXM1K-A6
	LGXXXN2K-G4	LGXXXM1C-A6
	LGXXXN2W-G4	LGXXXA1C-A6
	LGXXXS2C-G4	LGXXXQAC-A6
	LGXXXS2W-G4	LGXXXQAK-A6
	LGXXXN1C-V5	LGXXXN1K-B6
	LGXXXN1W-V5	LGXXXN2W-E6
	LGXXXN2T-V5	LGXXXN2T-E6
	LGXXXN2T-J5	LGXXXN1K-E6
	LGXXXN1T-V5	LGXXXN3K-V6
Longi	LR6-60-XXXM	LR4-60HPB-XXXM
	LR6-60BK-XXXM	LR4-60HIB-XXXM
	LR6-60HV-XXXM	LR4-60HPH-XXXM
	LR6-60PB-XXXM	LR4-60HIH-XXXM
	LR6-60PE-XXXM	LR6-60HIH-XXXM
	LR6-60PH-XXXM	LR6-60HIB-XXXM
	LR6-60HPB-XXXM	LR4-72HPH-XXXM
	LR6-60HPH-XXXM	
Meyer Burger	Meyer Burger Black*	Meyer Burger White*
mSolar	TXI6-XXX120BB	
Mission Solar	MSEXXS05T	MSEXXSQ4S
	MSEXXS05K	MSEXXS8K
	MSEXXSQ5T	MSEXXS8T
	MSEXXSQ5K	MSEXXS9S
	MSEXXM4J	MSE60AXXX
	MSEXXM6J	MSEXXS5K
	MSEXXS06W	MSEXXS5T
	MSEXXS04J	MSEXXS6S
	MSEXXS06J	MSEXXS6W
	MSEXXSQ6S	MSEXXS5R
Next Energy Alliance	USNEA-XXXM3-60	USNEA-XXXM3-72
	USNEA-XXXM3B-60	USNEA-XXXM3B-72
Panasonic	VBHNXXXKA03	VBHXXXRA18N
	VBHNXXXKA04	VBHXXXRA03K
	VBHNXXXSA17	EVPVXXX(K)
	VBHNXXXSA18	EVPVXXXH
	VBHN325SA17E	EVPVXXXPK
Phono Solar	PSXXXM-20/U	PSxxxM8GF-18/VH
	PSXXXMH-20/U	PSxxxM8GFH-18/VH
	PSxxxM8GF-24/TH	PSxxxM6-24/TH
	PSxxxM8GFH-24/TH	

Manufacturer	Model	
REC (All may be followed by "BLK" or "BLACK")	RECXXTP2	RECXXTP2SM 72 BLK2
	RECXXTP2-BLK	RECXXXAA
	RECXXNP	RECXXTP3M
	RECXXTP2M	RECXXTP4
	RECXXTP2M 72	RECXXXAA Pure
	RECXXTP2M 72 BLK	RECXXXAA Pure-R
	RECXXTP2M 72 BLK2	RECXXNP2
	RECXXTP2SM 72	RECXXNP3
	RECXXTP2SM 72 BLK	
SEG Solar	SEG-400-BMB-HV	SEG-xxx-BMD-HV
	SEG-400-BMB-TB	SEG-xxx-BMD-TB
Silfab	SLAXX-M	SILXXXNT
	SLAXX-P	SILXXXHL
	SSAXX-M	SILXXXBK
	SSAXX-P	SILXXXNX
	SILXXXBL	SILXXXNU
	SILXXXML	SILXXXHC
	SILXXXNL	SILXXXHN
	SLGXX-M	SILXXXBG
	SLGXX-P	SIL-xxxHC+
	SSGXX-M	SIL-xxxHM
	SSGXX-P	
Solaria	Solaria PowerXT-XXXR-PX	Solaria PowerXT-XXXR-PM
	Solaria PowerXT-XXXR-BX	Solaria PowerXT-XXXR-PM-AC
	Solaria PowerXT-XXXR-AC	
Sunpower	SPR-AXXX-G-AC	SPR-MXXX-H-AC
	SPR-AXXX	SPR-MXXX
	SPR-AXXX-BLK-G-AC	SPR-MXXX-BLK-H-AC
	SPR-AXXX-BLK	SPR-MXXX-BLK
SunSpark	SST-XXXM3-60	SST-XXXM3-72
	SST-XXXM3B-60	SST-XXXM3B-72
Talesun	TP660M-XXX	TP672M-XXX
	TP660P-XXX	TP672P-XXX
Trina	TSM-XXXDD05(II)	TSMXXXDD05H.05(II)
	TSM-XXXDD05A.05(II)	TSM-XXXDD06M.05(II)
	TSM-XXXDD05A.08(II)	TSM-XXXDE15H(II)
	TSM-XXXDD05A.082(II)	TSM-XXXDE15M(II)
	TSM-XXXPA05	TSMXXXDE06X.05(II)
	TSM-XXXPA05.05	TSMXXXDE09.05
	TSM-XXXPA05.08	TSM-XXXDE15V(II)
	TSM-XXXPD05	TSM-XXXDEG15VC.20(II)
	TSM-XXXPD05.002	TSM-XXXDEG18MC.20(II)
TSM-XXXPD05.05	TSM-XXXDEG19C.20	

Manufacturer	Model	
Trina	TSM-XXXPD05.05S	TSM-XXXDEG21C.20
	TSM-XXXPD05.08	TSM-XXXDE09C.05
	TSM-XXXPD05.082	TSM-XXXDE09C.07
	TSM-XXXPD05.08D	TSM-xxxNE09RC.05
	TSM-XXXPD05.08S	
Vikram Solar	SOMERA VSMHBB.60.XXX.05	PREXOS VSMDHT.60.XXX.05
	SOMERA VSMH.72.XXX.05	PREXOS VSMDHT.72.XXX.05
VSUN	VSUNXXX-144BMH-DG	VSUNXXX-108BMH
	VSUNXXX-120BMH	
ZNShine	ZXM6-60-XXX/M	ZXM6-NH144-XXXM
	ZXM6-NH120-XXXM	ZXM7-SH108-XXXM

**SnapNrack TopSpeed™ has been tested with the following Module Level Power Electronic (MLPE) devices:**

SnapNrack TopSpeed™ mounting systems has been tested with the following UL/NRTL Listed Module Level Power Electronic (MLPE) Devices. The back plates of the MLPEs have been evaluated for bonding to TopSpeed™ through the SnapNrack MLPE Frame Attachment Kit, model 242-02151.

MLPE Manufacturer	Model	
AP Smart	RSD-S-PLC	
Celestica International	DG-006-F001201x	DG-006-F001401x
Delta Electronics	GPI00010105	
Enphase	C250	IQ7PLUS-72-2-US
	M215	IQ7PLUS-72-B-US
	M250	IQ8-60
	IQ6-60-2-US	IQ8PLUS-72
	IQ6PLUS-72-2-US	IQ8A-72
	IQ7-60-2-US	IQ8H-208-72
	IQ7-60-B-US	IQ8H-240-72
Generec	S2502	
Ginlong Technologies	Solis-RSD-1G	
	Solis-MLRSD-R1-1G	Solis-MLRSD-R2-1G
SolarEdge	P300-5NC4ARS	P320-5NC4ARS
	P370-5NC4AFS	P400-5NC4AFS
	P320	P340
	P370	P400
	P401	P405
	P485	P505
	P730	P800p
	P850	P860
	P950	P1100
	P1101	S440
	S500	
	SMA	RSB-2S-US-10
Tigo	TS4-R-F	TS4-R-M
	TS4-R-O	TS4-R-S
	TS4-R-M-DUO	TS4-R-O-DUO
	TS4-R-S-DUO	TS4-A-F
	TS4-A-2F	TS4-A-O
	TS4-A-S	



# Hi-MO 5

## LR5-54HABB 390~415M

- Suitable for distributed projects
- Advanced module technology delivers superior module efficiency
  - M10 Gallium-doped Wafer • Integrated Segmented Ribbons • 9-busbar Half-cut Cell
- Globally validated bifacial energy yield
- High module quality ensures long-term reliability

 25-year Warranty for Materials and Processing

 30-year Warranty for Extra Linear Power Output

### Complete System and Product Certifications

IEC 61215, IEC 61730, UL 61730

ISO9001:2015: ISO Quality Management System

ISO14001: 2015: ISO Environment Management System

ISO45001: 2018: Occupational Health and Safety

IEC62941: Guideline for module design qualification and type approval

**LONGI**



# Hi-MO 5

# LR5-54HABB 390~415M

**21.3%**  
MAX MODULE  
EFFICIENCY

**0~3%**  
POWER  
TOLERANCE

**<2%**  
FIRST YEAR  
POWER DEGRADATION

**0.45%**  
YEAR 2-30  
POWER DEGRADATION

**HALF-CELL**  
Lower operating temperature

## Additional Value

### 30-Year Power Warranty

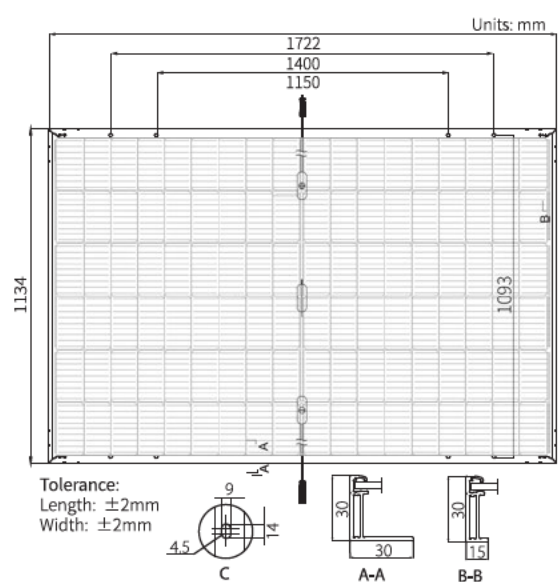
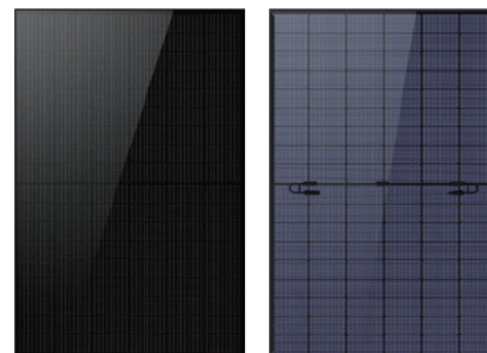
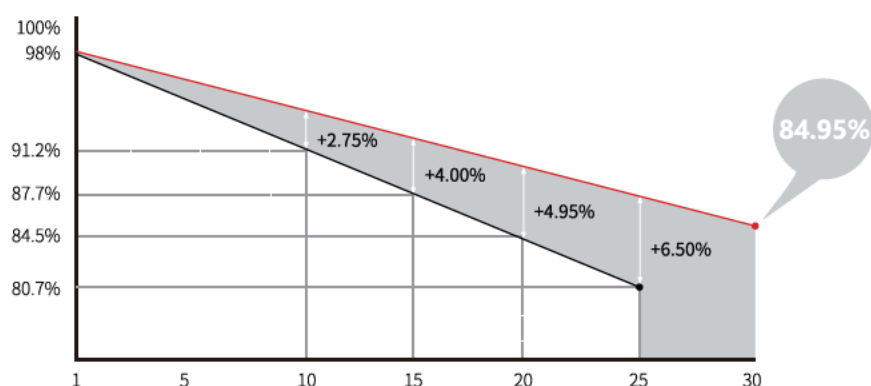

## Mechanical Parameters

Cell Orientation	108 (6×18)
Junction Box	IP68, three diodes
Output Cable	4mm <sup>2</sup> , ±1200mm length can be customized
Glass	Dual glass, 2.0+1.6mm heat strengthened glass
Frame	Anodized aluminum alloy frame
Weight	22.5kg
Dimension	1722×1134×30mm
Packaging	36pcs per pallet / 216pcs per 20' GP / 936pcs or 792pcs(Only for USA) per 40' HC

## Electrical Characteristics

STC : AM1.5 1000W/m<sup>2</sup> 25°C      NOCT : AM1.5 800W/m<sup>2</sup> 20°C 1m/s      Test uncertainty for Pmax: ±3%

Module Type	LR5-54HABB-390M		LR5-54HABB-395M		LR5-54HABB-400M		LR5-54HABB-405M		LR5-54HABB-410M		LR5-54HABB-415M	
	STC	NOCT	STC	NOCT	STC	NOCT	STC	NOCT	STC	NOCT	STC	NOCT
Maximum Power (Pmax/W)	390	291.5	395	295.2	400	299.0	405	302.7	410	306.5	415	310.2
Open Circuit Voltage (Voc/V)	36.58	34.39	36.81	34.61	37.05	34.84	37.29	35.06	37.53	35.29	37.77	35.51
Short Circuit Current (Isc/A)	13.57	10.95	13.65	11.01	13.72	11.07	13.79	11.13	13.87	11.19	13.94	11.25
Voltage at Maximum Power (Vmp/V)	30.47	28.43	30.70	28.64	30.94	28.86	31.18	29.09	31.42	29.31	31.66	29.54
Current at Maximum Power (Imp/A)	12.80	10.26	12.87	10.31	12.93	10.36	12.99	10.41	13.05	10.45	13.11	10.50
Module Efficiency(%)	20.0		20.2		20.5		20.7		21.0		21.3	

## Electrical characteristics with different rear side power gain (reference to 400W front)

Pmax /W	Voc/V	Isc /A	Vmp/V	Imp /A	Pmax gain
420	37.05	14.41	30.94	13.58	5%
440	37.05	15.09	30.94	14.22	10%
460	37.15	15.78	31.04	14.87	15%
480	37.15	16.46	31.04	15.52	20%
500	37.15	17.15	31.04	16.16	25%

## Operating Parameters

Operational Temperature	-40°C ~ +85°C
Power Output Tolerance	0 ~ 3%
Voc and Isc Tolerance	±3%
Maximum System Voltage	DC1500V (IEC/UL)
Maximum Series Fuse Rating	30A
Nominal Operating Cell Temperature	45±2°C
Protection Class	Class II
Bifaciality	70±5%
Fire Rating	UL Similar type 38 * IEC Class C

\*Reference Standard : UL61730 Second Edition, Dated October 28, 2022

## Mechanical Loading

Front Side Maximum Static Loading	5400Pa
Rear Side Maximum Static Loading	2400Pa
Hailstone Test	25mm Hailstone at the speed of 23m/s

## Temperature Ratings (STC)

Temperature Coefficient of Isc	+0.050%/°C
Temperature Coefficient of Voc	-0.265%/°C
Temperature Coefficient of Pmax	-0.340%/°C



No.8369 Shangyuan Road, Xi'an Economic And Technological Development Zone, Xi'an, Shaanxi, China.  
Web: www.longi.com

Specifications included in this datasheet are subject to change without notice. LONGI reserves the right of final interpretation. (20230115V17) Only for North America





# IQ8 and IQ8+ Microinverters

Our newest IQ8 Microinverters are the industry’s first microgrid-forming, software-defined microinverters with split-phase power conversion capability to convert DC power to AC power efficiently. The brain of the semiconductor-based microinverter is our proprietary application-specific integrated circuit (ASIC), which enables the microinverter to operate in grid-tied or off-grid modes. This chip is built using advanced 55-nm technology with high-speed digital logic and has superfast response times to changing loads and grid events, alleviating constraints on battery sizing for home energy systems.



Part of the Enphase Energy System, IQ8 Series Microinverters integrate with the IQ Battery, IQ Gateway, and the Enphase App monitoring and analysis software.



IQ8 Series Microinverters redefine reliability standards with more than one million cumulative hours of power-on testing, enabling an industry-leading limited warranty of up to 25 years.



Connect PV modules quickly and easily to IQ8 Series Microinverters using the included Q-DCC-2 adapter cable with plug-and-play MC4 connectors.



IQ8 Series Microinverters are UL Listed as PV rapid shutdown equipment and conform with various regulations, when installed according to the manufacturer’s instructions.

### Easy to install

- Lightweight and compact with plug-and-play connectors
- Power line communication (PLC) between components
- Faster installation with simple two-wire cabling

### High productivity and reliability

- Produce power even when the grid is down\*
- More than one million cumulative hours of testing
- Class II double-insulated enclosure
- Optimized for the latest high-powered PV modules

### Microgrid-forming

- Compliant with the latest advanced grid support\*\*
- Remote automatic updates for the latest grid requirements
- Configurable to support a wide range of grid profiles
- Meets CA Rule 21 (UL 1741-SA) and IEEE 1547:2018 (UL 1741-SB)

### NOTE:

- IQ8 Microinverters cannot be mixed with previous generations of Enphase microinverters (IQ7 Series, IQ6 Series, and so on) in the same system.
- IQ Microinverters ship with default settings that meet North America’s IEEE 1547 interconnection standard requirements. Region-specific adjustments may be requested by an Authority Having Jurisdiction (AHJ) or utility representative according to the IEEE 1547 interconnection standard. An IQ Gateway is required to make these changes during installation.

\*Meets UL 1741 only when installed with IQ System Controller 2 or 3.  
 \*\*IQ8 and IQ8+ support split-phase, 240 V installations only.

# IQ8 and IQ8+ Microinverters

INPUT DATA (DC)		UNITS	IQ8-60-2-US	IQ8PLUS-72-2-US
Commonly used module pairings <sup>1</sup>	W		235–350	235–440
Module compatibility	—	To meet compatibility, PV modules must be within maximum input DC voltage and maximum module $I_{sc}$ listed below. Module compatibility can be checked at <a href="https://enphase.com/installers/microinverters/calculator">https://enphase.com/installers/microinverters/calculator</a> .		
MPPT voltage range	V		27–37	27–45
Operating range	V		16–48	16–58
Minimum/Maximum start voltage	V		22/48	22/58
Maximum input DC voltage	V		50	60
Maximum continuous input DC current	A		10	12
Maximum input DC short-circuit current	A			25
Maximum module ( $I_{sc}$ )	A			20
Overvoltage class DC port	—			II
DC port backfeed current	mA			0
PV array configuration	—	Ungrounded array; no additional DC side protection required; AC side protection requires maximum 20 A per branch circuit.		
OUTPUT DATA (AC)		UNITS	IQ8-60-2-US	IQ8PLUS-72-2-US
Peak output power	VA		245	300
Maximum continuous output power	VA		240	290
Nominal grid voltage (L-L)	V		240, split-phase (L-L), 180°	
Minimum and Maximum grid voltage <sup>2</sup>	V		211–264	
Maximum continuous output current	A		1.0	1.21
Nominal frequency	Hz		60	
Extended frequency range	Hz		47–68	
AC short-circuit fault current over three cycles	Arms		2	
Maximum units per 20 A (L-L) branch circuit <sup>3</sup>	—		16	13
Total harmonic distortion	%		<5	
Overvoltage class AC port	—		III	
AC port backfeed current	mA		30	
Power factor setting	—		1.0	
Grid-tied power factor (adjustable)	—		0.85 leading ... 0.85 lagging	
Peak efficiency	%		97.7	
CEC weighted efficiency	%		97	
Nighttime power consumption	mW		23	25
MECHANICAL DATA				
Ambient temperature range			-40°C to 60°C (-40°F to 140°F)	
Relative humidity range			4% to 100% (condensing)	
DC connector type			MC4	
Dimensions (H × W × D)			212 mm (8.3 in) × 175 mm (6.9 in) × 30.2 mm (1.2 in)	
Weight			1.08 kg (2.38 lbs)	
Cooling			Natural convection—no fans	
Approved for wet locations			Yes	
Pollution degree			PD3	
Enclosure			Class II double-insulated, corrosion-resistant polymeric enclosure	
Environmental category/UV exposure rating			NEMA Type 6/Outdoor	

(1) No enforced DC/AC ratio.

(2) Nominal voltage range can be extended beyond nominal if required by the utility.

(3) Limits may vary. Refer to local requirements to define the number of microinverters per branch in your area.



COMPLIANCE

Certifications

CA Rule 21 (UL 1741-SA), UL 62109-1, IEEE 1547:2018 (UL 1741-SB), FCC Part 15 Class B, ICES-0003 Class B, CAN/CSA-C22.2 NO. 107.1-01.  
This product is UL Listed as PV rapid shutdown equipment and conforms with NEC 2014, NEC 2017, NEC 2020, and NEC 2023 section 690.12 and C22.1-2018 Rule 64-218 rapid shutdown of PV Systems, for AC and DC conductors, when installed according to the manufacturer's instructions.

## Revision history

REVISION	DATE	DESCRIPTION
DSH-00207-3.0	February 2024	Updated the information about IEEE 1547 interconnection standard requirements.
DSH-00207-2.0	October 2023	Included NEC 2023 specification in the “Compliance” section.
DSH-00207-1.0	September 2023	Updated module compatibility specification.

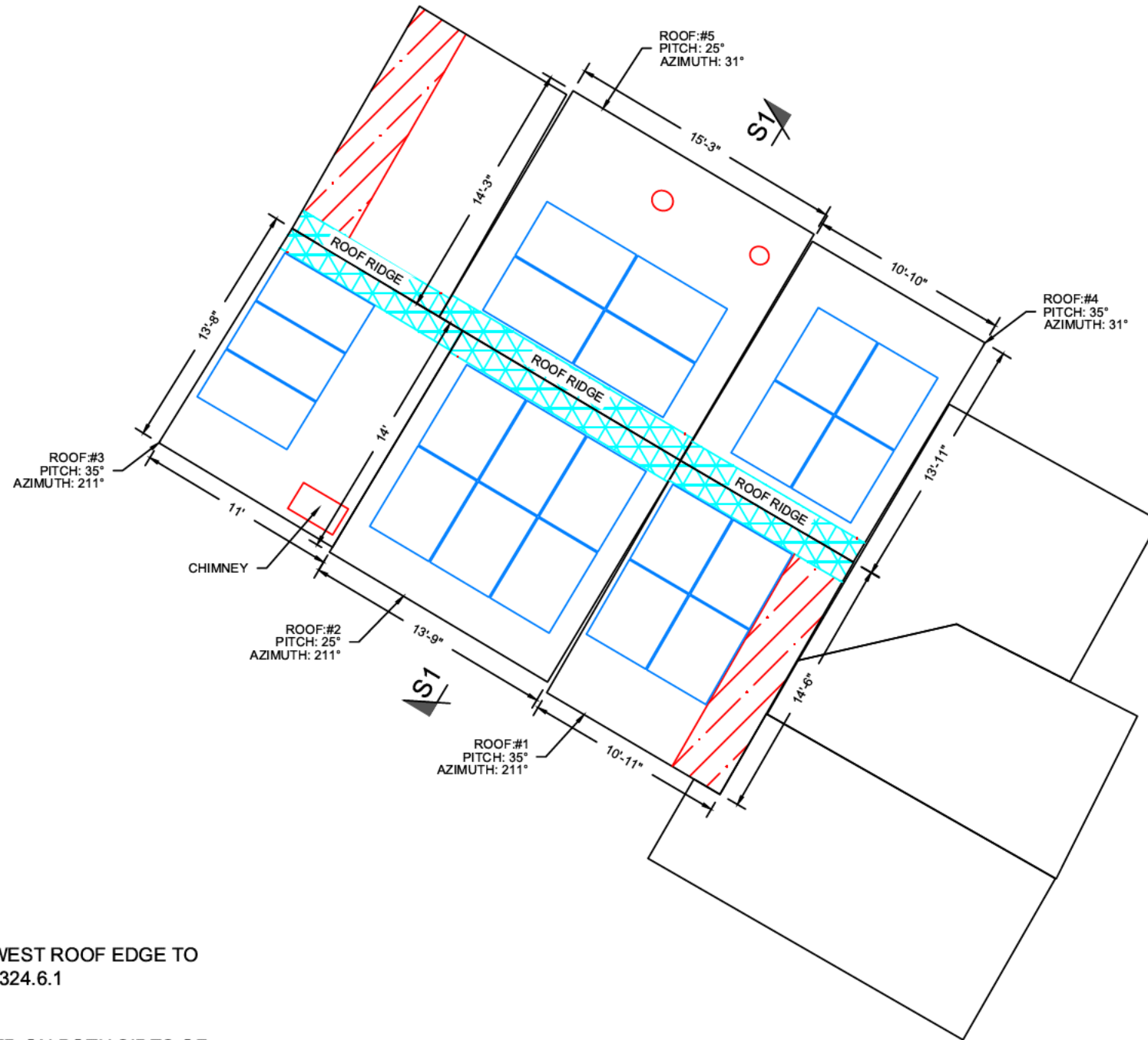
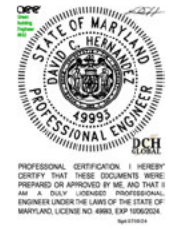

- KEY**
- FIRE SAFETY ZONE
  - 3' PATHWAYS FROM LOWEST ROOF EDGE TO RIDGE PROVIDED PER R324.6.1
  - 1'6" PATHWAYS PROVIDED ON BOTH SIDES OF RIDGE PER R324.6.2

PLAN VIEW TOTAL ROOF AREA: 1698 SQFT  
 SOLAR ARRAY AREA: 441.42 SQFT  
 THE SOLAR ARRAY IS 26.0% OF THE PLAN VIEW TOTAL ROOF AREA

- NOTES:**
1. THE SYSTEM SHALL INCLUDE (21) LONGI LR5-54HABB-400M.
  2. SNAPRACK TOPSPEED WILL BE INSTALLED IN ACCORDANCE WITH SNAPRACK INSTALLATION MANUAL.
  3. REFER TO STRUCTURAL DRAWING FOR SECTIONS MARKED AND ADDITIONAL NOTES.

**SOLAR PANEL LAYOUT**  
 Scale: 1/8" = 1'-0"



**Solar Energy World**  
 Because Tomorrow Matters

Solar Energy World LLC.  
 14880 Sweitzer Lane  
 Laurel, MD 20707  
 (888) 497-3233

---

**Disclaimer:**  
 This drawing is the property of Solar Energy World Inc. The information herein contained shall be used for the sole benefit of Solar Energy World. It shall not be disclosed to others outside the recipient's organization, in whole or in part, without the written permission of Solar Energy World, except in connection with the sale and use of the respective Solar Energy equipment.

---

Building Code	
International Residential Code (IRC) 2018	
Electrical Code	
National Electrical Code (NEC) 2017	
Wind Speed	Snow Load
115 MPH	30 PSF
Module	
(21) LONGi LR5-54HABB-400M	
Inverter(s)	
(21) IQ8+-72-2-US	
DC System Size	AC System Size
8.400 kW	6.090 kW
Customer Information	
Judith Appelbaum & Elizabeth Cohn 7209 Willow Ave Takoma Park, MD 20912	
Permit/License	
None	
City	Utility
Montgomery	Pepco
Sheet Name	
Solar Panel Layout	
Drawn By	Date
PV	July 8, 2024
Scale	Job Number
AS NOTED	MD19815
Sheet	
A-1	



David C. Hernande  
 Digitally signed by David C. Hernande  
 Date: 2024.07.08 12:11:51 -04:00

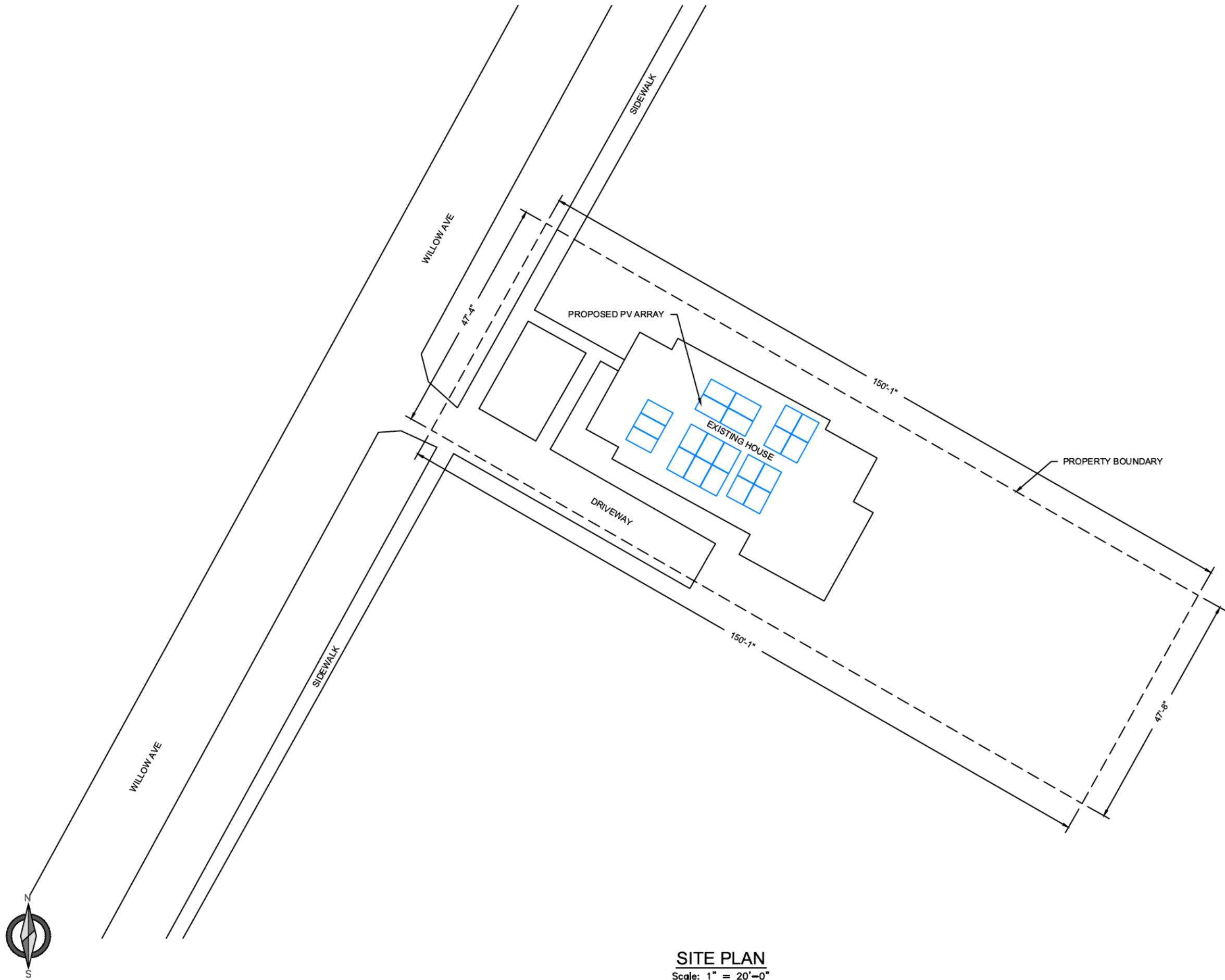

**SITE PLAN**  
 Scale: 1" = 20'-0"



**Solar Energy World**  
 Because Tomorrow Matters

Solar Energy World LLC.  
 14880 Sweitzer Lane  
 Laurel, MD 20707  
 (888) 497-3233

**Disclaimer:**  
 This drawing is the property of Solar Energy World Inc. The information herein contained shall be used for the sole benefit of Solar Energy World. It shall not be disclosed to others outside the recipient's organization, in whole or in part, without the written permission of Solar Energy World, except in connection with the sale and use of the respective Solar Energy equipment.

<b>Building Code</b> International Residential Code (IRC) 2018	
<b>Electrical Code</b> National Electrical Code (NEC) 2017	
<b>Wind Speed</b> 115 MPH	<b>Snow Load</b> 30 PSF
<b>Module</b> (21) LONGi LR5-54HABB-400M	
<b>Inverter(s)</b> (21) IQ8+-72-2-US	
<b>DC System Size</b> 8.400 kW	<b>AC System Size</b> 6.090 kW
<b>Customer Information</b> Judith Appelbaum & Elizabeth Cohn 7209 Willow Ave Takoma Park, MD 20912	
<b>Permit/License</b> None	
<b>City</b> Montgomery	<b>Utility</b> Pepco
<b>Sheet Name</b> Site Plan	
<b>Drawn By</b> PV	<b>Date</b> July 8, 2024
<b>Scale</b> AS NOTED	<b>Job Number</b> MD19815
<b>Sheet</b> A-2	

David C. Hernande  
 Digitally signed by David C. Hernande  
 Date: 2024.07.08 12:11:51 -04:00

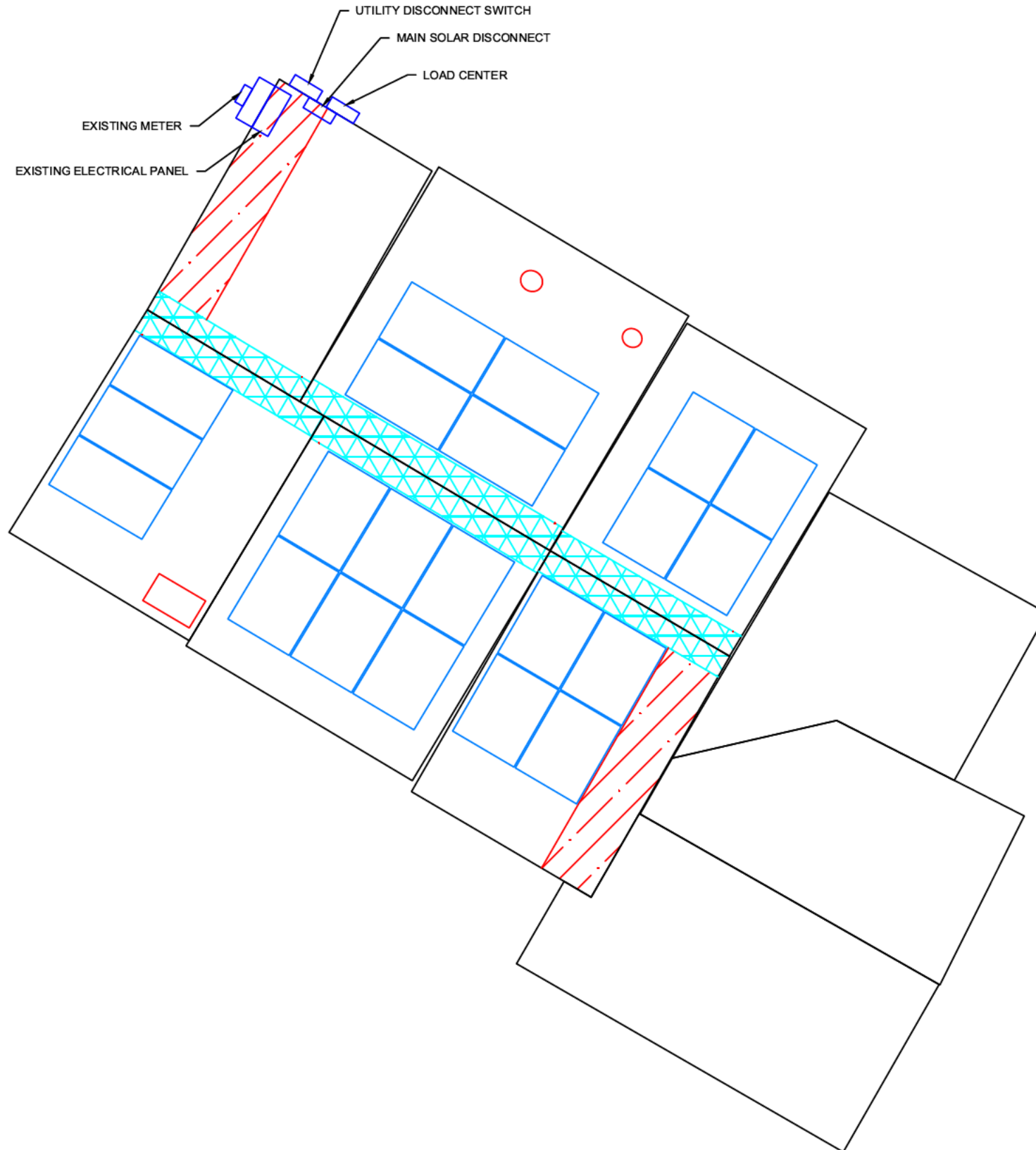
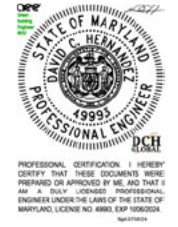

**EQUIPMENT LOCATION PLAN**  
 Scale: NTS

**NOTE:**  
 EQUIPMENT LOCATION PLAN IS APPROXIMATE, EXACT LOCATION TO BE VERIFIED WITH INSTALLATION CREW AND HOME OWNER AT THE TIME OF INSTALLATION.



**Solar Energy World**  
 Because Tomorrow Matters

Solar Energy World LLC.  
 14880 Sweitzer Lane  
 Laurel, MD 20707  
 (888) 497-3233

**Disclaimer:**  
 This drawing is the property of Solar Energy World Inc. The information herein contained shall be used for the sole benefit of Solar Energy World. It shall not be disclosed to others outside the recipient's organization, in whole or in part, without the written permission of Solar Energy World, except in connection with the sale and use of the respective Solar Energy equipment.

<b>Building Code</b> International Residential Code (IRC) 2018	
<b>Electrical Code</b> National Electrical Code (NEC) 2017	
<b>Wind Speed</b> 115 MPH	<b>Snow Load</b> 30 PSF
<b>Module</b> (21) LONGi LR5-54HABB-400M	
<b>Inverter(s)</b> (21) IQ8+-72-2-US	
<b>DC System Size</b> 8.400 kW	<b>AC System Size</b> 6.090 kW
<b>Customer Information</b> Judith Appelbaum & Elizabeth Cohn 7209 Willow Ave Takoma Park, MD 20912	
<b>Permit/Landsc</b> None	
<b>City</b> Montgomery	<b>Utility</b> Pepco
<b>Sheet Name</b> Equipment Location Plan	
<b>Drawn By</b> PV	<b>Date</b> July 8, 2024
<b>Scale</b> AS NOTED	<b>Job Number</b> MD19815
<b>Sheet</b> E-1	



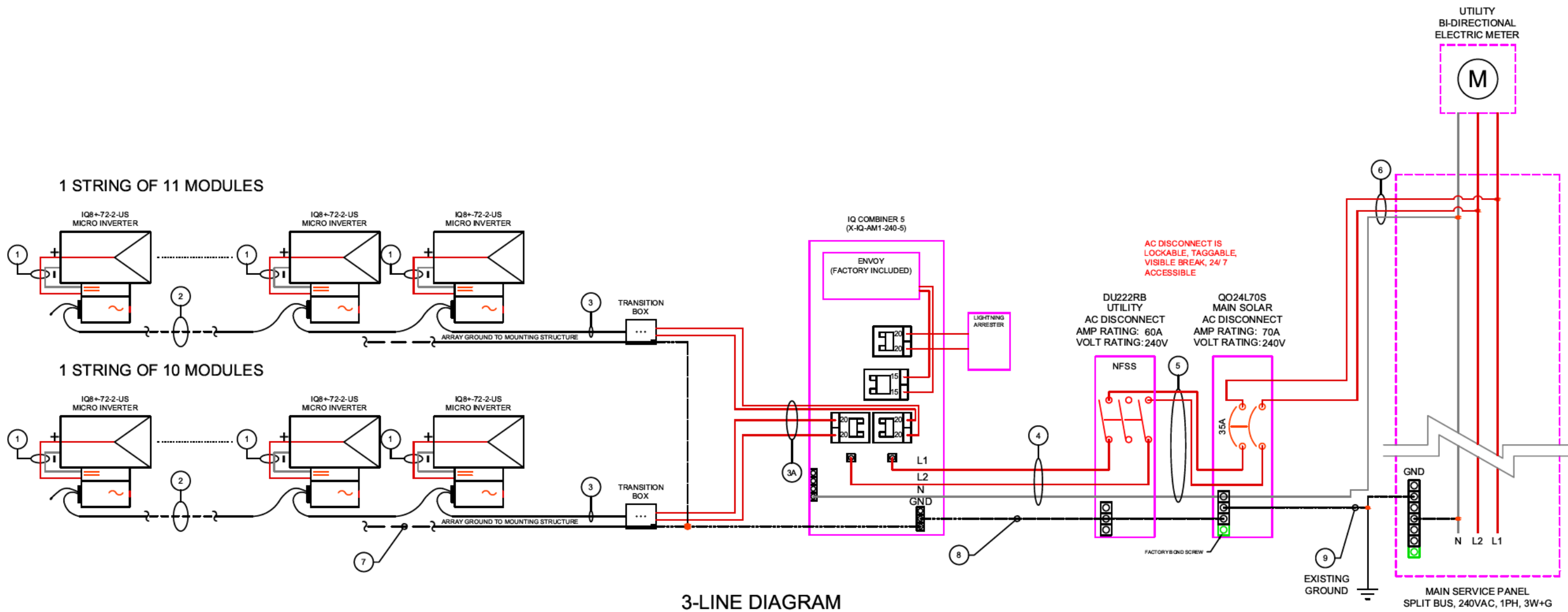

**3-LINE DIAGRAM**

MODULE SPECIFICATIONS		
MODEL NUMBER	LR5-54HABB-400M	
PEAK POWER	400 W	
RATED VOLTAGE (V <sub>mpp</sub> )	30.94 V	
RATED CURRENT (I <sub>mp</sub> )	12.93 A	
OPEN CIRCUIT VOLTAGE (V <sub>oc</sub> )	37.05 V	
SHORT CIRCUIT CURRENT (I <sub>sc</sub> )	13.72 A	
MAXIMUM SYSTEM VOLTAGE	1000VDC	
INVERTER SPECIFICATIONS		
MODEL NUMBER	IQ8PLUS-72-2-US	
MAXIMUM DC VOLTAGE	60 V	
MAXIMUM POWER OUTPUT	290 W	
NOMINAL AC VOLTAGE	240 VAC	
MAXIMUM AC CURRENT	1.21 A	
CEC EFFICIENCY	97.0%	
ARRAY DETAILS		
NO. OF MODULES PER STRING	11	10
NO. OF STRINGS	1	1
ARRAY WATTS AT STC	4400	4000
MAX. VOLTAGE	480 V	480 V

WIRE/CONDUIT SCHEDULE ARRAY			
TAG	DESCRIPTION	WIRE SIZE/TYPE	NOTES
1	Panel to Micro Inverter	PV Wire (Factory Made)	INTEGRATED
2	Micro Inverter to Micro Inverter	Pre-Manufactured Cable	
3	Micro Inverter to Transition Box	Pre-Manufactured Cable	
3A	Transition Box to Load Center	#10 THHN/THWN-2	INTEGRATED
4	Load Center to AC Disconnect	#8 Cu THHN/THWN-2	
5	AC Disconnect to AC Disconnect	#8 Cu THHN/THWN-2	
6	AC Disconnect to Interconnection Point	#6 Cu THHN/THWN-2	
7	Equipment Grounding Conductor	#8 Cu Bare Copper Wire	
8	Equipment Grounding Conductor	#8 Cu THHN/THWN-2	
9	Grounding Electrode Conductor	#6 Cu	

**GENERAL ELECTRIC NOTES: NEC2017**

- EQUIPMENT USED SHALL BE NEW, UNLESS OTHERWISE NOTED.
- EQUIPMENT USED SHALL BE UL LISTED, UNLESS OTHERWISE NOTED.
- EQUIPMENT SHALL BE INSTALLED PROVIDING ADEQUATE PHYSICAL WORKING SPACE AROUND THE EQUIPMENT AND SHALL COMPLY WITH NEC.
- COPPER CONDUCTORS SHALL BE USED AND SHALL HAVE AN INSULATION RATING OF 600V, 90°C, UNLESS OTHERWISE NOTED.
- CONDUCTORS SHALL BE SIZED IN ACCORDANCE TO THE NEC. CONDUCTORS AMPACITY SHALL BE DE-RATED FOR TEMPERATURE INCREASE, CONDUIT FILL AND VOLTAGE DROP.
- EXPOSED NON-CURRENT CARRYING METAL PARTS SHALL BE GROUNDED AS PER NEC.
- CONDUITS SHALL BE ADEQUATELY SUPPORTED AS PER NEC.
- AC DISCONNECT SHOWN IS REQUIRED IF THE UTILITY REQUIRES VISIBLE-BLADE SWITCH.
- ASHRAE FUNDAMENTAL OUTDOOR DESIGN TEMPERATURES DO NOT EXCEED 47°C IN THE U.S. (PHOENIX, AZ OR PALM SPRINGS, CA)
- SMS MONITORING SYSTEM AND IT'S CONNECTION SHOWN IS OPTIONAL. IF USED, REFER TO SMS INSTALLATION MANUAL FOR WIRING METHODS AND OPERATION PROCEDURE.
- FOR LESS THAN 9 CURRENT-CARRYING CONDUCTORS IN ROOF MOUNTED SUNLIGHT CONDUIT USING THE OUTDOOR TEMPERATURE OF 47°C
- 10AWG CONDUCTOR ARE GENERALLY ACCEPTABLE FOR MODULES WITH AN I<sub>sc</sub> OF 9.6 AMPS WITH A 15 AMP FUSE.
- WIRE SIZING FOR OCPD  
EX (I<sub>sc</sub> \* (1.25)(1.25) / # OF STRINGS IN PARALLEL) = WIRE AMPACITY OR USING NEC TABLE 690.8



**Solar Energy World**  
Because Tomorrow Matters

Solar Energy World LLC.  
14880 Sweitzer Lane  
Laurel, MD 20707  
(888) 497-3233

---

**Disclaimer:**  
This drawing is the property of Solar Energy World Inc. The information herein contained shall be used for the sole benefit of Solar Energy World. It shall not be disclosed to others outside the recipient's organization, in whole or in part, without the written permission of Solar Energy World, except in connection with the sale and use of the respective Solar Energy equipment.

---

Building Code International Residential Code (IRC) 2018	
Electrical Code National Electrical Code (NEC) 2017	
Wind Speed 115 MPH	Show Load 30 PSF
Module (21) LONGi LR5-54HABB-400M	
Inverter(s) (21) IQ8+72-2-US	
DC System Size 8.400 kW	AC System Size 6.090 kW
Customer Information Judith Appelbaum & Elizabeth Cohn 7209 Willow Ave Takoma Park, MD 20912	
Permit/License None	
City Montgomery	Utility Pepco
Sheet Name Electrical 3-Line Diagram	
Drawn By PV	Date July 8, 2024
Scale AS NOTED	Job Number MD19815
Sheet E-2	

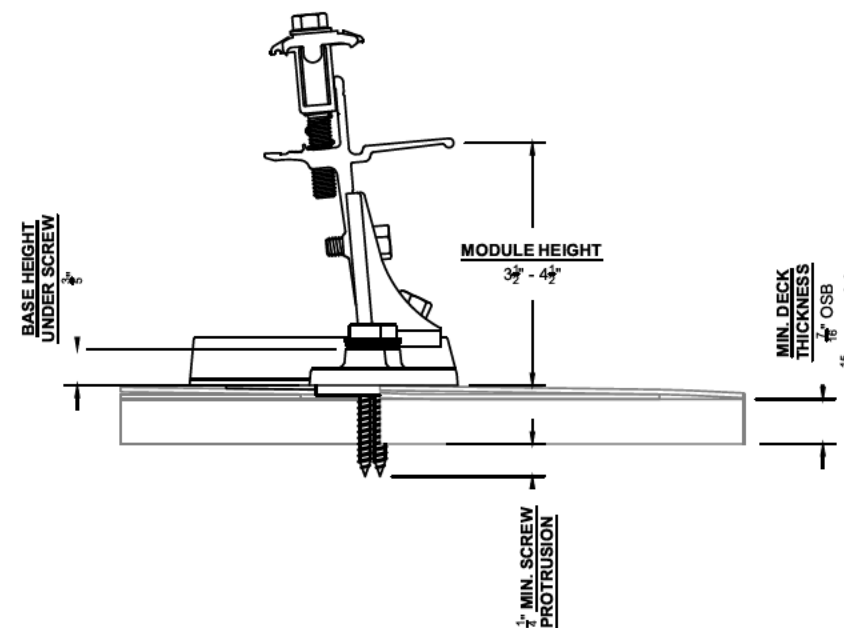
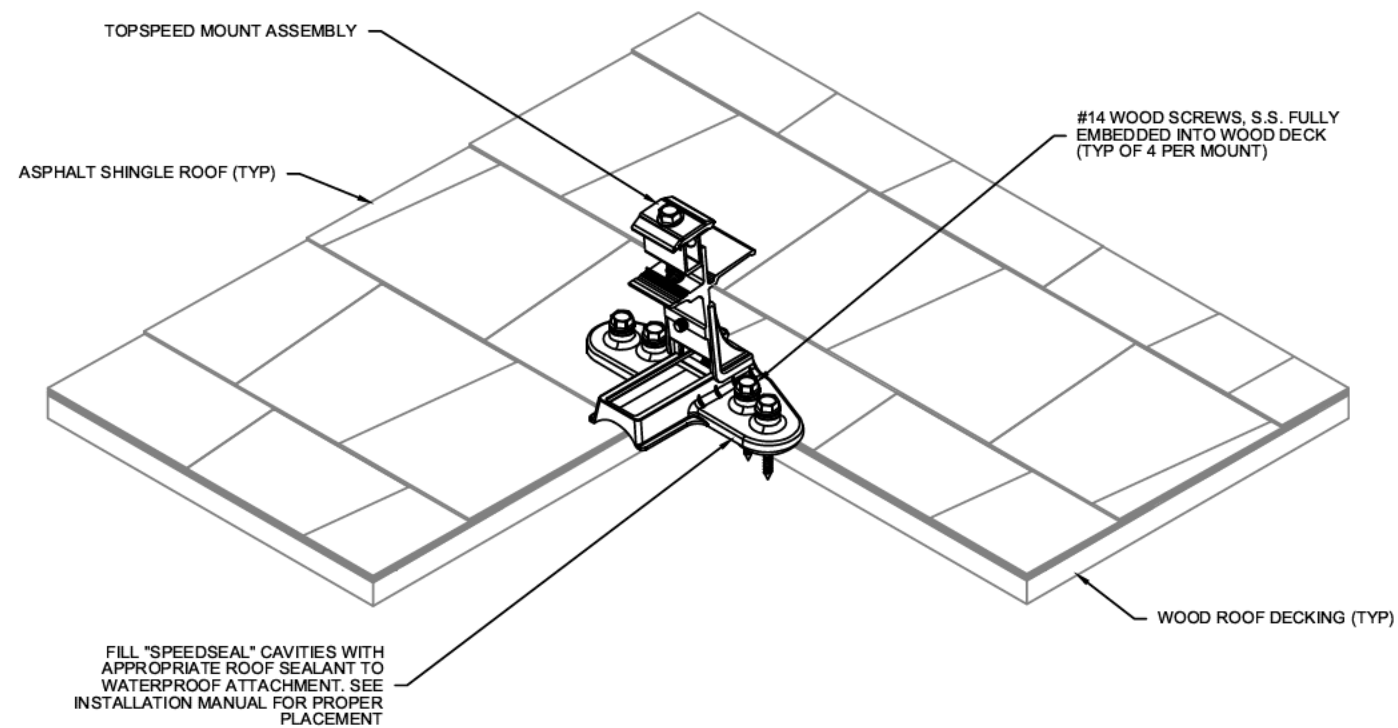
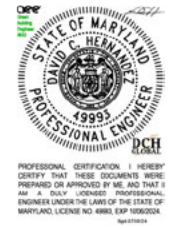

### Structural Details

S1	Rafter	2x6 O.C. 18"
----	--------	--------------

**NOTES:**

- ALL WORK SHALL COMPLY WITH REQUIREMENTS OF INTERNATIONAL RESIDENTIAL CODE (IRC 2018), LOADING CODE (ASCE 7-16), WOOD DESIGN CODE (NDS 2015), AND LOCAL REQUIREMENTS.
- LOAD CRITERIA PER :
  - EXPOSURE CATEGORY "B"
  - GROUND SNOW LOAD,  $P_g = 30$  PSF
  - LATERAL LOAD RISK CATEGORY "II"
  - ULTIMATE DESIGN WIND SPEED = 115 MPH
- SOLAR PANELS AND RACKING SYSTEMS SHALL BE INSTALLED PER MANUFACTURER'S RECOMMENDATION.
- FOLLOW ALL LOCAL AND FEDERAL SAFETY REQUIREMENTS.

### STRUCTURAL ATTACHMENT DETAIL



**Solar Energy World**  
Because Tomorrow Matters

Solar Energy World LLC.  
14880 Sweitzer Lane  
Laurel, MD 20707  
(888) 497-3233

**Disclaimer:**  
 This drawing is the property of Solar Energy World Inc. The information herein contained shall be used for the sole benefit of Solar Energy World. It shall not be disclosed to others outside the recipient's organization, in whole or in part, without the written permission of Solar Energy World, except in connection with the sale and use of the respective Solar Energy equipment.

Building Code International Residential Code (IRC) 2018	
Electrical Code National Electrical Code (NEC) 2017	
Wind Speed 115 MPH	Snow Load 30 PSF
Module (21) LONGi LR5-54HABB-400M	
Inverter(s) (21) IQ8+-72-2-US	
DC System Size 8.400 kW	AC System Size 6.090 kW
Customer Information Judith Appelbaum & Elizabeth Cohn 7209 Willow Ave Takoma Park, MD 20912	
Permit/Landsc. None	
City Montgomery	Utility Pepco
Sheet Name Structural Attachment Details	
Drawn By PV	Date July 8, 2024
Scale AS NOTED	Job Number MD19815
Sheet S-1	

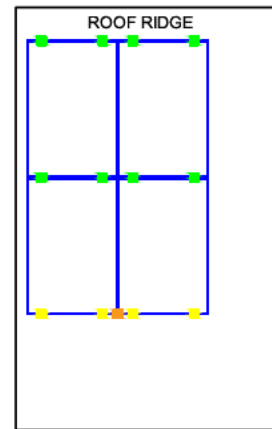
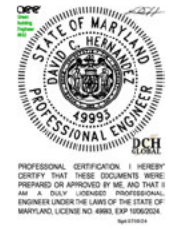

**SOLAR PANEL FOOTING PLAN R1**  
 Scale: 1/8" = 1'-0"

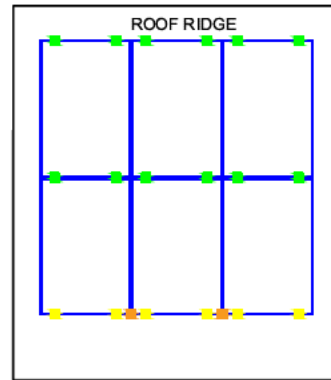

**SOLAR PANEL FOOTING PLAN R2**  
 Scale: 1/8" = 1'-0"

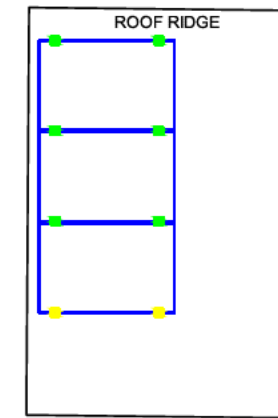

**SOLAR PANEL FOOTING PLAN R3**  
 Scale: 1/8" = 1'-0"

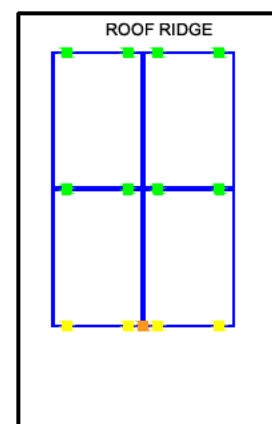

**SOLAR PANEL FOOTING PLAN R4**  
 Scale: 1/8" = 1'-0"

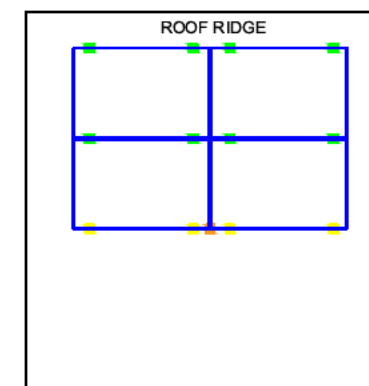

**SOLAR PANEL FOOTING PLAN R5**  
 Scale: 1/8" = 1'-0"

**KEY**

-  MOUNTS WITHOUT SPACERS
-  MOUNTS WITH SPACERS
-  CLAMPS WITHOUT SPACERS
-  CLAMPS WITH SPACERS

**NOTES:**

1. SNAPRACK TOPSPEED SHALL BE INSTALLED IN ACCORDANCE WITH SNAPRACK INSTALLATION MANUAL.
2. ADD TOPSPEED CLAMP IF GREATER THAN (SOLAR PANEL LENGTH / 4) FOR LANDSCAPE OR (SOLAR PANEL WIDTH / 4) FOR PORTRAIT
3. NO SOLAR PANEL SHALL CANTILEVER MORE THAN 1/4 SOLAR PANEL LENGTH OR WIDTH DEPENDING ON ORIENTATION. UNLESS FOR MANUFACTURER SPECIFIED CLAMPING ZONE



**Solar Energy World**  
 Because Tomorrow Matters

Solar Energy World LLC.  
 14880 Sweitzer Lane  
 Laurel, MD 20707  
 (888) 497-3233

**Disclaimer:**  
 This drawing is the property of Solar Energy World Inc. The information herein contained shall be used for the sole benefit of Solar Energy World. It shall not be disclosed to others outside the recipient's organization, in whole or in part, without the written permission of Solar Energy World, except in connection with the sale and use of the respective Solar Energy equipment.

<b>Building Code</b>	
International Residential Code (IRC) 2018	
<b>Electrical Code</b>	
National Electrical Code (NEC) 2017	
<b>Wind Speed</b>	<b>Show Load</b>
115 MPH	30 PSF
<b>Module</b>	
(21) LONGi LR5-54HABB-400M	
<b>Inverter(s)</b>	
(21) IQ8+-72-2-US	
<b>DC System Size</b>	<b>AC System Size</b>
8.400 kW	6.090 kW
<b>Customer Information</b>	
Judith Appelbaum & Elizabeth Cohn 7209 Willow Ave Takoma Park, MD 20912	
<b>Permit/Landscaper</b>	
None	
<b>City</b>	<b>Utility</b>
Montgomery	Pepco
<b>Sheet Name</b>	
Solar Panel Footing Plan	
<b>Drawn By</b>	<b>Date</b>
PV	July 8, 2024
<b>Scale</b>	<b>Job Number</b>
AS NOTED	MD19815
<b>Sheet</b>	
S-2	



by Schneider Electric

List Price \$353.00 USD

Availability **Stock Item: This item is normally stocked in our distribution facility.**

**Technical Characteristics**

Number of Poles	2-Pole
Terminal Type	Lugs
Type of Duty	General Duty
Maximum Voltage Rating	240VAC
Wire Size	#10 to #2 AWG(Al) - #14 to #2 AWG(Cu)
Action	Single Throw
Ampere Rating	60A
Approvals	UL Listed File Number E2875
Enclosure Rating	NEMA 3R
Enclosure Type	Rainproof and Sleet/Ice proof (Indoor/Outdoor)
Factory Installed Neutral	No
Disconnect Type	Non-Fusible
Mounting Type	Surface

**Shipping and Ordering**

Category	00106 - Safety Switch, General Duty, 30 - 200 Amp, NEMA3R
Discount Schedule	DE1A
GTIN	00785901491491
Package Quantity	1
Weight	4.7 lbs.
Availability Code	Stock Item: This item is normally stocked in our distribution facility.
Returnability	Y
Country of Origin	MX

As standards, specifications, and designs change from time to time, please ask for confirmation of the information given in this document.



X-IQ-AM1-240-5  
X-IQ-AM1-240-5C

# IQ Combiner 5/5C

The IQ Combiner 5/5C consolidates interconnection equipment into a single enclosure and streamlines IQ Series Microinverters and IQ Gateway installation by providing a consistent, pre-wired solution for residential applications. IQ Combiner 5/5C uses wired control communication and is compatible with IQ System Controller 3/3G and IQ Battery 5P.

The IQ Combiner 5/5C, IQ Series Microinverters, IQ System Controller 3/3G, and IQ Battery 5P provide a complete grid-agnostic Enphase Energy System.



**IQ Series Microinverters**  
The high-powered smart grid-ready IQ Series Microinverters (IQ6, IQ7, and IQ8 Series) simplify the installation process.



**IQ System Controller 3/3G**  
Provides microgrid interconnection device (MID) functionality by automatically detecting grid failures and seamlessly transitioning the home energy system from grid power to backup power.



**IQ Battery 5P**  
Fully integrated AC battery system. Includes six field-replaceable IQ8D-BAT Microinverters.



**IQ Load Controller**  
Helps prioritize essential appliances during a grid outage to optimize energy consumption and prolong battery life.

### Smart

- Includes IQ Gateway for communication and control
- Includes Enphase Mobile Connect (CELLMODEM-M1-06-SP-05), only with IQ Combiner 5C
- Supports flexible networking: Wi-Fi, Ethernet, or cellular
- Provides production metering (revenue grade) and consumption monitoring

### Easy to install

- Mounts to one stud with centered brackets
- Supports bottom, back, and side conduit entries
- Supports up to four 2-pole branch circuits for 240 VAC plug-in breakers (not included)
- 80 A total PV branch circuits
- Bluetooth-based Wi-Fi provisioning for easy Wi-Fi setup

### Reliable

- Durable NRTL-certified NEMA type 3R enclosure
- 5-year limited warranty
- 2-year labor reimbursement program coverage included for both the IQ Combiner SKUs\*
- UL1741 Listed



5-year limited warranty

\*For country-specific warranty information, see the <https://enphase.com/installers/resources/warranty> page.



# IQ Combiner 5/5C

MODEL NUMBER	
IQ Combiner 5 (X-IQ-AM1-240-5)	IQ Combiner 5 with IQ Gateway printed circuit board for integrated revenue-grade PV production metering (ANSI C12.20 $\pm 0.5\%$ ), consumption monitoring ( $\pm 2.5\%$ ), and IQ Battery monitoring ( $\pm 2.5\%$ ). Includes a silver solar shield to deflect heat.
IQ Combiner 5C (X-IQ-AM1-240-5C)	IQ Combiner 5C with IQ Gateway printed circuit board for integrated revenue-grade PV production metering (ANSI C12.20 $\pm 0.5\%$ ), consumption monitoring ( $\pm 2.5\%$ ) and IQ Battery monitoring ( $\pm 2.5\%$ ). Includes Enphase Mobile Connect cellular modem (CELLMODEM-M1-06-SP-05) <sup>1</sup> . Includes a silver solar shield to deflect heat.
WHAT'S IN THE BOX	
IQ Gateway printed circuit board	IQ Gateway is the platform for total energy management for comprehensive, remote maintenance, and management of the Enphase Energy System
Busbar	80 A busbar with support for one IQ Gateway breaker and four 20 A breaker for installing IQ Series Microinverters and IQ Battery 5P
IQ Gateway breaker	Circuit breaker, 2-pole, 10 A/15 A
Production CT	Pre-wired revenue-grade solid-core CT, accurate up to $\pm 0.5\%$
Consumption CT	Two consumption metering clamp CTs, shipped with the box, accurate up to $\pm 2.5\%$
IQ Battery CT	One battery metering clamp CT, shipped with the box, accurate up to $\pm 2.5\%$
CTRL board	Control board for wired communication with IQ System Controller 3/3G and the IQ Battery 5P
Enphase Mobile Connect (only with IQ Combiner 5C)	4G-based LTE-M1 cellular modem (CELLMODEM-M1-06-SP-05) with a 5-year T-Mobile data plan
Accessories kit	Spare control headers for the COMMS-KIT-02 board
ACCESSORIES AND REPLACEMENT PARTS (NOT INCLUDED, ORDER SEPARATELY)	
CELLMODEM-M1-06-SP-05	4G-based LTE-M1 cellular modem with a 5-year T-Mobile data plan
CELLMODEM-M1-06-AT-05	4G-based LTE-M1 cellular modem with a 5-year AT&T data plan
Circuit breakers (off-the-shelf)	Supports Eaton BR2XX, Siemens Q2XX and GE/ABB THQL21XX Series circuit breakers (XX represents 10, 15, 20, 30, 40, 50, or 60). Also supports Eaton BR220B, BR230B, and BR240B circuit breakers compatible with the hold-down kit.
Circuit breakers (provided by Enphase)	BRK-10A-2-240V, BRK-15A-2-240V, BRK-20A-2P-240V, BRK-15A-2P-240V-B, and BRK-20A-2P-240V-B (more details in the "Accessories" section)
XA-SOLARSHIELD-ES	Replacement solar shield for IQ Combiner 5/5C
XA-ENV2-PCBA-5	IQ Gateway replacement printed circuit board (PCB) for IQ Combiner 5/5C
X-IQ-NA-HD-125A	Hold-down kit compatible with Eaton BR-B Series circuit breakers (with screws)
XA-COMMS2-PCBA-5	Replacement COMMS-KIT-02 printed circuit board (PCB) for IQ Combiner 5/5C
ELECTRICAL SPECIFICATIONS	
Rating	80 A
System voltage and frequency	120/240 VAC, 60 Hz
Busbar rating	125 A
Fault current rating	10 kAIC
Maximum continuous current rating (input from PV/storage)	64 A
Branch circuits (solar and/or storage)	Up to four 2-pole Eaton BR, Siemens Q, or GE/ABB THQL Series distributed generation (DG) breakers only (not included)
Maximum total branch circuit breaker rating (input)	80 A of distributed generation/95 A with IQ Gateway breaker included
IQ Gateway breaker	10 A or 15 A rating GE/Siemens/Eaton included
Production metering CT	200 A solid core pre-installed and wired to IQ Gateway
Consumption monitoring CT (CT-200-CLAMP)	A pair of 200 A clamp-style current transformers is included with the box
IQ Battery metering CT	200 A clamp-style current transformer for IQ Battery metering, included with the box

<sup>1</sup> A plug-and-play industrial-grade cell modem for systems of up to 60 microinverters. Available in the United States, Canada, Mexico, Puerto Rico, and the US Virgin Islands, where there is adequate cellular service in the installation area.

## MECHANICAL DATA

Dimensions (W × H × D)	37.5 cm × 49.5 cm × 16.8 cm (14.75" × 19.5" × 6.63"). Height is 53.5 cm (21.06") with mounting brackets.
Weight	7.5 kg (16.5 lb)
Ambient temperature range	-40°C to 46°C (-40°F to 115°F)
Cooling	Natural convection, plus heat shield
Enclosure environmental rating	Outdoor, NRTL-certified, NEMA type 3R, polycarbonate construction
Wire sizes	<ul style="list-style-type: none"> <li>• 20 A to 50 A breaker inputs: 14 to 4 AWG copper conductors</li> <li>• 60 A breaker branch input: 4 to 1/0 AWG copper conductors</li> <li>• Main lug combined output: 10 to 2/0 AWG copper conductors</li> <li>• Neutral and ground: 14 to 1/0 copper conductors</li> <li>• Always follow local code requirements for conductor sizing</li> </ul>
Communication (in-premise connectivity)	Built-in CTRL board for wired communication with the IQ Battery 5P and the IQ System Controller 3/3G. Integrated power line communication for IQ Series Microinverters.
Altitude	Up to 2,600 meters (8,530 feet)

## COMMUNICATION INTERFACES

Integrated Wi-Fi	802.11b/g/n (dual band 2.4 GHz/5 GHz) for connecting the Enphase Cloud through the internet.
Wi-Fi range (recommended)	10 m (32.8 feet)
Bluetooth	BLE4.2, 10 m range to configure Wi-Fi SSID
Ethernet	Optional, 802.3, Cat5E (or Cat 6) UTP Ethernet cable (not included) for connecting to the Enphase Cloud through the internet.
Cellular/Mobile Connect	CELLMODEM-M1-06-SP-05 or CELLMODEM-M1-06-AT-05 (included with the IQ Combiner 5C)
Digital I/O	Digital input/output for grid operator control
USB 2.0	Mobile Connect, COMMS-KIT-01 for IQ Battery 3/3T/10/10T, COMMS-KIT-02 for IQ Battery 5P
Access point (AP) mode	For connection between the IQ Gateway and a mobile device running the Enphase Installer App
Metering ports	Up to two Consumption CTs, one IQ Battery CT, and one Production CT
Power line communication	90–110 kHz
Web API	See <a href="https://developer-v4.enphase.com">https://developer-v4.enphase.com</a>
Local API	See Guide for local API at <a href="https://enphase.com/download/accessing-iq-gateway-local-apis-or-local-ui-token-based-authentication">https://enphase.com/download/accessing-iq-gateway-local-apis-or-local-ui-token-based-authentication</a>

## COMPLIANCE

IQ Combiner with IQ Gateway	UL 1741, CAN/CSA C22.2 No. 107.1, Title 47 CFR, Part 15, Class B, ICES 003, NOM-208-SCFI-2016, UL 60601-1/CANCSA 22.2 No. 61010-1, IEEE 1547: 2018 (UL 1741-SB, 3rd Ed.), IEEE 2030.5/CSIP Compliant, Production metering: ANSI C12.20 accuracy class 0.5 (PV production)
-----------------------------	---

## COMPATIBILITY

PV	Microinverters	IQ6, IQ7, and IQ8 Series Microinverters
COMMS-KIT-01 <sup>2</sup>	IQ System Controller	EP200G101-M240US00
	IQ System Controller 2	EP200G101-M240US01
	IQ Battery	ENCHARGE-3-1P-NA, ENCHARGE-10-1P-NA, ENCHARGE-3T-1P-NA, ENCHARGE-10T-1P-NA
COMMS-KIT-02 <sup>3</sup>	IQ System Controller 3	SC200D111C240US01, SC200G111C240US01
	IQ Battery	IQBATTERY-5P-1P-NA

<sup>2</sup> For information about IQ Combiner 5/5C compatibility with the 2<sup>nd</sup>-generation batteries, refer to the compatibility matrix at <https://enphase.com/download/compatibility-matrix>.

<sup>3</sup> IQ Combiner 5/5C comes pre-equipped with COMMS-KIT-02.

# Accessories



## Mobile Connect

4G-based LTE-M1 cellular modem with a 5-year data plan  
(CELLMODEM-M1-06-SP-05 for Sprint and  
CELLMODEM-M1-06-AT-05 for AT&T)



## Circuit breakers

BRK-10A-2-240V Circuit breaker, 2-pole, 10 A, Eaton BR210  
BRK-15A-2-240V Circuit breaker, 2-pole, 15 A, Eaton BR215  
BRK-20A-2P-240V Circuit breaker, 2-pole, 20 A, Eaton BR220  
BRK-15A-2P-240V-B Circuit breaker, 2-pole, 15 A, Eaton BR215B  
with hold-down kit support  
BRK-20A-2P-240V-B Circuit breaker, 2-pole, 20 A, Eaton  
BR220B with hold-down kit support



## CT-200-SOLID

200 A revenue-grade solid core Production CT  
with <0.5% error rate (replacement SKU)



## CT-200-CLAMP

200 A clamp-style consumption and battery  
metering CT with <2.5% error rate (replacement  
SKU)

# Revision history

REVISION	DATE	DESCRIPTION
DSH-00007-4.0	June 2024	Updated the UL smart mark.
DSH-00007-3.0	March 2024	Updated accessories and replacement parts, communication interfaces, and compatibility specifications.
DSH-00007-2.0	September 2023	Included Bluetooth specifications.
DSH-00007-1.0	May 2023	Initial release.

7/31/2024

To whom it may concern,

- Justification of panels on the front of the house and heat map.

Monthly energy consumption for 7209 Willow Avenue, Takoma Park, MD 20912  
vs the proposed system monthly production

## Your monthly Electricity use in kWh

Daily temperature averages: May 2023: 62° F May 2024: 64° F

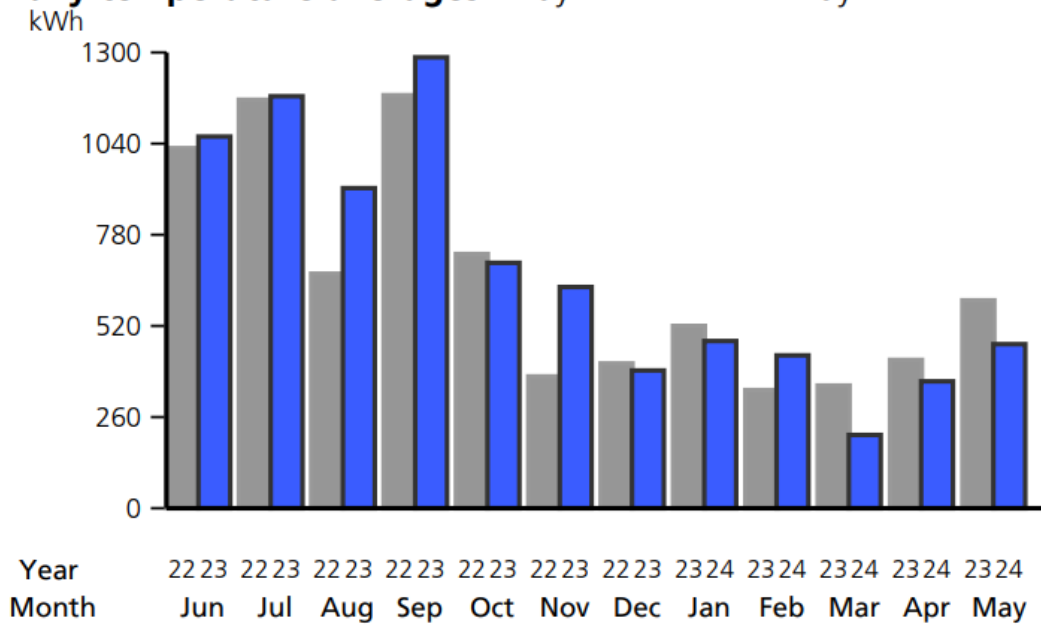

Monthly Average Solar Access



Monthly Consumption and Production (kWh)

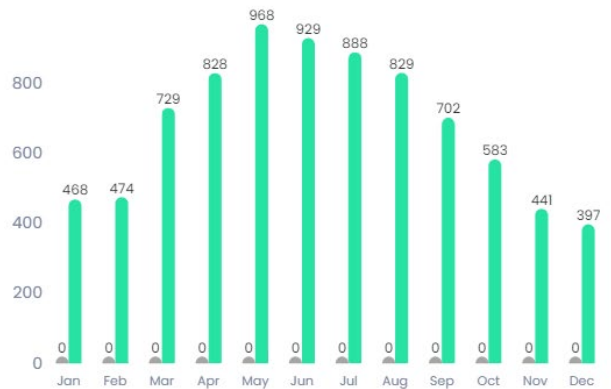



- The home had an annual usage of roughly 8,770 kWh in 2023. Our proposed system is estimated to have 8,237 kWh in annual production.

The panels will vary in production based on their location on the structure, but this estimated production for a 21-panel system breaks down to roughly 392 kWh per panel annually. The roof plane closest to the front of the home has an average of 462 kWh per panel annually. The other roof planes with panels proposed have an average of 370 kWh per panel annually. The panels on the front of the roof produce more than those on the back. The system production estimate of 8,237 kWh is 533 kWh less than the consumption for the household.

#### **Justification for the Placement of the panels.**

- All usable space in the midsection of the home is being utilized in this design. The front-facing roof plane is not used, but the 3-panel array near the front of the home has the highest production of the remaining roof space.
- The rear roof planes are not used as they are lower and heavily shaded by trees to the southeast.

#### **Shade Map.**



Thank you,  
Aley Oberdorf  
Design Engineer.

# Product data sheet

Specifications

SQUARE D

Green Premium™



Load center, QO, 1 phase, 2 spaces, 4 circuits, 70A fixed main lugs, NEMA1, surface cover

QO24L70S

Product availability: Stock - Normally stocked in distribution facility

**Price\*: 69.00 USD**

## Main

Marketing Trade Name	QO
Product Type	Load Center
Cover Type	Surface cover

## Complementary

Tightening Torque	Main lugs 35 lb.in, AWG 14...AWG 10, aluminium/copper Main lugs 45 lb.in, AWG 3, aluminium/copper Main lugs 40 lb.in, AWG 8...AWG 4, aluminium/copper Main lugs 35 lb.in, AWG 12...AWG10, aluminium/copper
PoN Convertible Mains (lugs)	Fixed Mains (lugs)
Rated Current	70 A
Number of Spaces	2
Max Short Circuit Current Rating	65 kA
Maximum Number of Single Pole Circuits	4
Maximum Number of Tandem Breakers	2
Number of Phases	1 phase 3 wires
Voltage Rating	120/240 V AC
Wire Size	AWG 12...AWG 3 aluminium AWG 14...AWG 4 copper
Ground Bar	Grounding bar (ordered separately)
Electrical Connection	Lugs
Busbar Material	Tin plated aluminium: busbar
Enclosure Material	Welded sheet steel
Surface Finish	Baked enamel Gray
Box Number	2
Height	9.3 in (236 mm)
Width	4.8 in (122 mm)

## Environment

Enclosure Rating	NEMA 1 indoor enclosure
Ambient Air Temperature for Operation	23.000000000 °F (-5 °C) 104 °F (40 °C)

Price is "List Price" and may be subject to a trade discount – check with your local distributor or retailer for actual price.

---

Product Certifications	UL Listed
------------------------	-----------

## Ordering and shipping details

---

Category	US1DE3A00101
----------	--------------

---

Discount Schedule	DE3A
-------------------	------

---

GTIN	785901785149
------	--------------

---

Returnability	Yes
---------------	-----

---

Country of origin	MX
-------------------	----

## Packing Units

---

Unit Type of Package 1	PCE
------------------------	-----

---

Number of Units in Package 1	1
------------------------------	---

---

Package 1 Height	4.09 in (10.4 cm)
------------------	-------------------

---

Package 1 Width	6.4 in (16.3 cm)
-----------------	------------------

---

Package 1 Length	11.3 in (28.7 cm)
------------------	-------------------

---

Package 1 Weight	3.73 lb(US) (1.69 kg)
------------------	-----------------------

---

Unit Type of Package 2	PAL
------------------------	-----

---

Number of Units in Package 2	213
------------------------------	-----

---

Package 2 Height	4.09 in (10.4 cm)
------------------	-------------------

---

Package 2 Width	6.4 in (16.3 cm)
-----------------	------------------

---

Package 2 Length	11.3 in (28.7 cm)
------------------	-------------------

---

Package 2 Weight	793.60 lb(US) (359.97 kg)
------------------	---------------------------

## Contractual warranty

---

Warranty	18 months
----------	-----------

## Sustainability

**Green Premium™ label** is Schneider Electric's commitment to delivering products with best-in-class environmental performance. Green Premium promises compliance with the latest regulations, transparency on environmental impacts, as well as circular and low-CO<sub>2</sub> products.

**Guide to assessing product sustainability** is a white paper that clarifies global eco-label standards and how to interpret environmental declarations.

[Learn more about Green Premium >](#)

[Guide to assess a product's sustainability >](#)



Transparency RoHS/REACH

## Well-being performance

Mercury Free

Rohs Exemption Information Yes

## Certifications & Standards

Reach Regulation [REACH Declaration](#)

Eu Rohs Directive Compliant with Exemptions

China Rohs Regulation [China RoHS declaration](#)  
Product out of China RoHS scope. Substance declaration for your information.

Environmental Disclosure [Product Environmental Profile](#)

Circularity Profile No need of specific recycling operations

California Proposition 65 WARNING: This product can expose you to chemicals including: Lead and lead compounds, which is known to the State of California to cause cancer and birth defects or other reproductive harm. For more information go to [www.P65Warnings.ca.gov](http://www.P65Warnings.ca.gov)



DEPARTMENT OF PERMITTING SERVICES

Marc Elrich  
*County Executive*

Rabbiah Sabbakhan  
*Director*

# HISTORIC AREA WORK PERMIT APPLICATION

Application Date: 7/9/2024

Application No: 1077703  
AP Type: HISTORIC  
Customer No: 1408761

## Affidavit Acknowledgement

The Contractor is the Primary applicant authorized by the property owner  
This application does not violate any covenants and deed restrictions

## Primary Applicant Information

Address 7209 WILLOW AVE  
TAKOMA PARK, MD 20912

Othercontact Solar Energy World (Primary)

## Historic Area Work Permit Details

Work Type ALTER

Scope of Work Install (21) roof mounted solar panels, 8.40 kW



Site Visit 7.31.24  
Front and left-  
side elevations





Site Visit 7.31.24  
Front and left-  
side elevations





Site Visit 7.31.24  
Front and left-  
side elevations





Site Visit 7.31.24  
Front and right-  
side elevations





Site Visit 7.31.24  
Adjacent  
property

