



APPLICATION FOR HISTORIC AREA WORK PERMIT
HISTORIC PRESERVATION COMMISSION
301.563.3400

FOR STAFF ONLY:
HAWP#
DATE ASSIGNED

APPLICANT:

Name: Village Concrete, Inc
Address: 11250 Industrial Road
Daytime Phone: 703-365-8544

E-mail: skhalatbari@villageconcrete.com
City: Manassas Zip: 20109
Tax Account No.: F14414411

AGENT/CONTACT (if applicable):

Name: Agostinho Costa COSTA ENTERPRISES LLC
Address: 13460 Saratoga Springs Way
Daytime Phone: 703-926-7645

E-mail: acosta@villageconcrete.com
City: Nokesville Zip: 20181
Contractor Registration No.: 2705095065

LOCATION OF BUILDING/PREMISE: MIHP # of Historic Property 10305 Armory Avenue

Is the Property Located within an Historic District? X Yes/District Name
No/Individual Site Name

Is there an Historic Preservation/Land Trust/Environmental Easement on the Property? If YES, include a map of the easement, and documentation from the Easement Holder supporting this application.

Are other Planning and/or Hearing Examiner Approvals /Reviews Required as part of this Application? (Conditional Use, Variance, Record Plat, etc.?) If YES, include information on these reviews as supplemental information.

Building Number: 10305 Street: ARMORY AVENUE
Town/City: KENSINGTON Nearest Cross Street: BALTIMORE ST
Lot: 8 Block: 9 Subdivision: 0015 Parcel:

TYPE OF WORK PROPOSED: See the checklist on Page 4 to verify that all supporting items for proposed work are submitted with this application. Incomplete Applications will not be accepted for review. Check all that apply:

- Checklist of work types: New Construction, Addition, Demolition, Grading/Excavation, Deck/Porch, Fence (REMOVAL), Hardscape/Landscape, Roof, Shed/Garage/Accessory Structure, Solar, Tree removal/planting, Window/Door, Other: DRAINAGE

I hereby certify that I have the authority to make the foregoing application, that the application is correct and accurate and that the construction will comply with plans reviewed and approved by all necessary agencies and hereby acknowledge and accept this to be a condition for the issuance of this permit.

Signature: Agostinho Costa

Date: 03.27.24

Signature of owner or authorized agent

Date



APPLICATION FOR HISTORIC AREA WORK PERMIT
HISTORIC PRESERVATION COMMISSION
301.563.3400

FOR STAFF ONLY:
HAWP#
DATE ASSIGNED

APPLICANT:

Name:
Address:
Daytime Phone:
E-mail:
City:
Zip:
Tax Account No.:

AGENT/CONTACT (if applicable):

Name:
Address:
Daytime Phone:
E-mail:
City:
Zip:
Contractor Registration No.:

LOCATION OF BUILDING/PREMISE: MIHP # of Historic Property

Is the Property Located within an Historic District? Yes/District Name
No/Individual Site Name

Is there an Historic Preservation/Land Trust/Environmental Easement on the Property? If YES, include a map of the easement, and documentation from the Easement Holder supporting this application.

Are other Planning and/or Hearing Examiner Approvals /Reviews Required as part of this Application? (Conditional Use, Variance, Record Plat, etc.?) If YES, include information on these reviews as supplemental information.

Building Number: Street:

Town/City: Nearest Cross Street:

Lot: Block: Subdivision: Parcel:

TYPE OF WORK PROPOSED: See the checklist on Page 4 to verify that all supporting items for proposed work are submitted with this application. Incomplete Applications will not be accepted for review. Check all that apply:

- New Construction
Addition
Demolition
Grading/Excavation
Deck/Porch
Fence
Hardscape/Landscape
Roof
Shed/Garage/Accessory Structure
Solar
Tree removal/planting
Window/Door
Other:

I hereby certify that I have the authority to make the foregoing application, that the application is correct and accurate and that the construction will comply with plans reviewed and approved by all necessary agencies and hereby acknowledge and accept this to be a condition for the issuance of this permit.

Signature of owner or authorized agent

Date

HAWP APPLICATION: MAILING ADDRESSES FOR NOTIFYING
[Owner, Owner's Agent, Adjacent and Confronting Property Owners]

Owner's mailing address	Owner's Agent's mailing address
Adjacent and confronting Property Owners mailing addresses	

Description of Property: Please describe the building and surrounding environment. Include information on significant structures, landscape features, or other significant features of the property:

Description of Work Proposed: Please give an overview of the work to be undertaken:

Work Item 1: _____

Description of Current Condition:

Proposed Work:

Work Item 2: _____

Description of Current Condition:

Proposed Work:

Work Item 3: _____

Description of Current Condition:

Proposed Work:

**HISTORIC AREA WORK PERMIT
CHECKLIST OF
APPLICATION REQUIREMENTS**

	Required Attachments						
Proposed Work	I. Written Description	2. Site Plan	3. Plans/Elevations	4. Material Specifications	5. Photographs	6. Tree Survey	7. Property Owner Addresses
New Construction	*	*	*	*	*	*	*
Additions/Alterations	*	*	*	*	*	*	*
Demolition	*	*	*		*		*
Deck/Porch	*	*	*	*	*	*	*
Fence/Wall	*	*	*	*	*	*	*
Driveway/Parking Area	*	*		*	*	*	*
Grading/Excavation/Landscaping	*	*		*	*	*	*
Tree Removal	*	*		*	*	*	*
Siding/ Roof Changes	*	*	*	*	*		*
Window/Door Changes	*	*	*	*	*		*
Masonry Repair/Repoint	*	*	*	*	*		*
Signs	*	*	*	*	*		*

ITEM 4

SUMMATION OF PROJECT

WITH COMMENTS FROM MAY 22 PRELIMINARY REVIEW , IT WAS DECIDED TO REWORK PROJECT TO THE FOLLOWING

SITE

- 1) SMALLER DRIVEWAY FOOTPRINT AND USING EXISTING CURBCUT APRON LOCATION
- 2) DRYWELL ADDED/PROPOSED FOR COUNTY DRAINAGE REQUIREMENTS
- 3) REMOVAL OF ONLY 2 TREES LARGER THAN 6" DIA
- 4) REUSING EXISTING FLAGSTONE PAVERS TO CREATE WALK TO REAR AND OUTBUILDING
- 5) REMOVING FENCE BETWEEN FRONT AND BACK YARDS.
- 6) NEW 12X18 DECK AND STEPS USING TREX OVER PRESSURE TREATED STRUCTURE
- 7) NEW 26.5X 24 ONE STORY ADDITION AND BASEMENT OFFSET FROM LEFT PROPERTY LINE TO MEET KENSINGTON EXCEPTION SETBACK REQUIREMENTS.

EXISTING BUILDING EXTERIOR CHANGES- THE INTENT IS TO KEEP MOST OF THE EXISTING CONDITIONS INTACT AND JUST PAINT/REPAIR WITH THE FOLLOWING EXCEPTIONS:

- 1) NEW ARCHITECTURAL SHINGLES AT EXST ROOF
- 2) REPLACE ALL EXST WINDOWS AT SIDES DUE TO SOME BEING COMPOSITE AND CONDITION OF OTHER ORIGINAL WOOD WINDOWS (STORM WINDOWS BEING RETAINED WHERE EXISTING)
- 3) REMOVAL OF FAN AT PORCH
- 4) PROPOSED NEW FRONT DOOR BUT WILLING TO KEEP EXISTING IF NECESSARY
- 5) 2 NEW CMU EGRESS WELLS AT EXISTING HOUSE
- 6) NEW 1 STORY ADDITION WITH ONE EGRESS WELL AT BASEMENT
- 7) CLOSING IN OF UPPER ATTIC WINDOW ON EXISTING REAR FACADE
- 8) NEW DECK TREX OVER PRESSURE TREATED STRUCTURE
- 9) BLACK EXTERIOR WINDOWS WERE ELIMINATED AND NOW ALL ARE TO BE WHITE.
- 10) PAINT/REPAIR GARAGE AS NEEDED

OLDER PHOTO

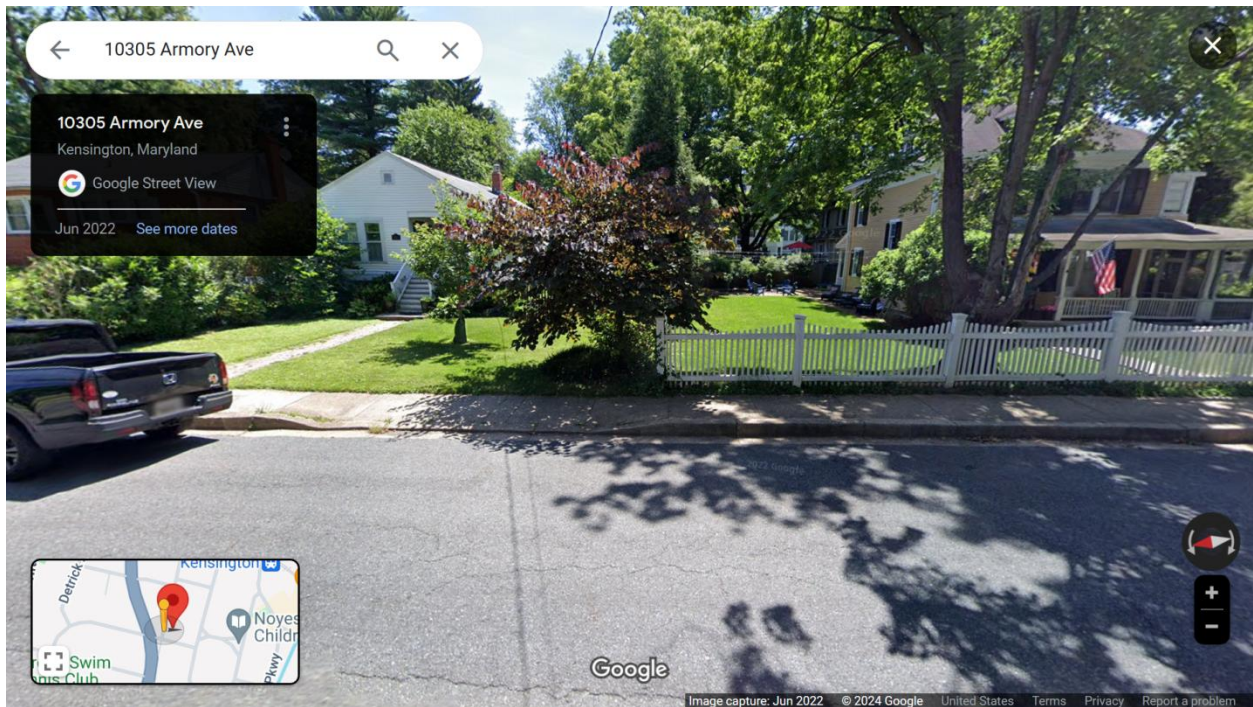

EXISTING CURB CUT APRON PHOTO...PROPOSING USING EXISTING APRON AND CREATING CONCRETE DRIVE AS SHOWN ON SURVEY MARKUP. 5" DIA REDBUD TREE IN FOREGROUND IS IN PUBLIC RIGHT OF WAY (PROPERTY LINES START ABOUT 5 FT BACK FROM SIDEWALK. OWNER TO WORK WITH KENSINGTON TO REPLACE. TREE AT LEFT IS 5" DIA TRUNK WHICH IS INTENDED TO BE REMOVED .



CLOSER PHOTO MORE CURRENT.



FRONT FACADE/GENERAL

OWNER PROPOSES TO LEAVE ALL CURRENT CLADDINGS AND FINISHES INTACT EXCEPT REMOVE PORCH FAN AND CAP WITH PLATE AT CEILING (PAINTED TO MATCH CEILING). WINDOWS TO REMAIN WITH WHITE FINISH AND BE REPAIRED



CURRENT DETACHED GARAGE. REPAIR AND REPLACE EXISTING SIDING AS REQUIRED. POSSIBLY RESHINGLE ROOF TO MATCH HOUSE. PAINT GARAGE SIDING COLOR (TBD) TO MATCH HOUSE WITH A WHITE TRIM . NO PROPOSED OTHER CHANGES EXST FENCING AT LOT LINES REMAIN. THERE IS NO LONGER A BASKETBALL HOOP OR SOCCER NET (PREVIOUS OWNER)



REAR YARD PHOTO.....TERRACE SHOWN IN LEFT FOREGROUND TO BE REMOVED FOR NEW ADDITION.
CONIFER TREES ALONG FENCE LINE TO BE TRIMMED BACK AS REQUIRED TO CLEAR NEW ADDITION 7'
PROPERTY LINE OFFSET.



NEW ADDITION APPLIED TO THE REAR 6' OFFSET AT LEFT , 7' FT OFFSET FROM PROPERTY LINE AT RIGHT. UPPER WINDOW IN GABLE TO BE FILLED IN. THIS CURRENT REAR FACADE IS A LATER ADDITION TO THE ORIGINAL HOUSE FOOTPRINT FROM 1920. EXISTING SIDING AND AWNING WINDOW AT RIGHT REMAINS EXISTING.





EXISTING SOUTH FACADE WINDOW CONDITIONS . ALL FINISHES AND CLADDINGS REMAIN EXISTING ON THIS SIDE WITH THE FOLLOWING EXCEPTIONS. CLIENT WOULD LIKE TO REPLACE THE EXISTING 1ST FLOOR WINDOWS DUE TO CONDITION OF ORIGINAL 3 AT LEFT AND REPLACE COMPOSITE ONE AT RIGHT. STORM WINDOWS RETAINED WHERE THEY EXIST NOW. 2 NEW EGRESS WINDOWS AT BASEMENT WITH CINDERBLOCK PARGED EGRESS WELLS.



METER TO BE UPDATED (NO SERVICE UPGRADE 200 AMP ASSUMED- VERIFY) CABLE/DATA SERVICE TBD MOUNTED IN SIMILAR GENERAL LOCATION. FENCE SHOWN IN PHOTO WILL BE REMOVED TO ALLOW NEW PROPOSED DRIVEWAY . NO REPLACEMENT FENCE PLANNED.



SOUTH FACADE WITH VIEW OF TREE TO BE REMOVED.



PORCH FAN TO BE REMOVED AND CAPPED PAINTED TO MATCH CEILING. ALL OTHER FINISHES /CLADDINGS REMAIN INTACT.



CLOSE UP SHOT OF FRONT STAIRS. REMAINS EXISTING



FRONT DOOR IS PROPOSED TO BE REPLACED. SUGGESTION OF REUSING REAR DOOR AT THIS LOCATION IS NOT PREFERRED FOR IT IS A SMALLER DOOR IN WIDTH. PROPOSED NEW DOOR IS INCLUDED , BUT EXISTING SINGLE LITE CAN REMAIN IF AN ISSUE. OTHER CLADDINGS AND FINISHES REMAIN INTACT.



CURRENT LIVING RM WINDOW PHOTO.



TYPICAL EXISTING WINDOW CONDITION AT EXTERIOR. EVERYTHING PROPOSED TO REMAIN INTACT EXCEPT OWNER PROPOSES TO REPLACE ALL THE WINDOWS AT EACH SIDE DUE TO EITHER BEING COMPOSITE OR CONDITION OF ORIGINAL WINDOWS. NOTE FOR SOME REASON NORTH SIDE DOES NOT HAVE GRILLES WHERE SOUTH SIDE DOES. OWNER PROPOSES 6 LITE OVER 1 FOR ALL CONDITIONS. (FRONT LIVING RM WINDOWS REMAIN WITH NO GRILLES)



NORTH FACADE....CURRENT DOWNPSPOUTS DRAIN INTO UNDERGROUND DRAINAGE CONNECTION TO FRENCH DRAIN . EXISTING SYSTEM WILL BE RETAINED ALONG WITH DOWNPSPOUTS AND GUTTERS WINDOWS SIZES REMAIN SAME ALONG THIS SIDE OF HOUSE. ALL CONDITIONS REMAIN INTACT EXCEPT OWNER PROPOSES TO REPLACE WINDOWS.

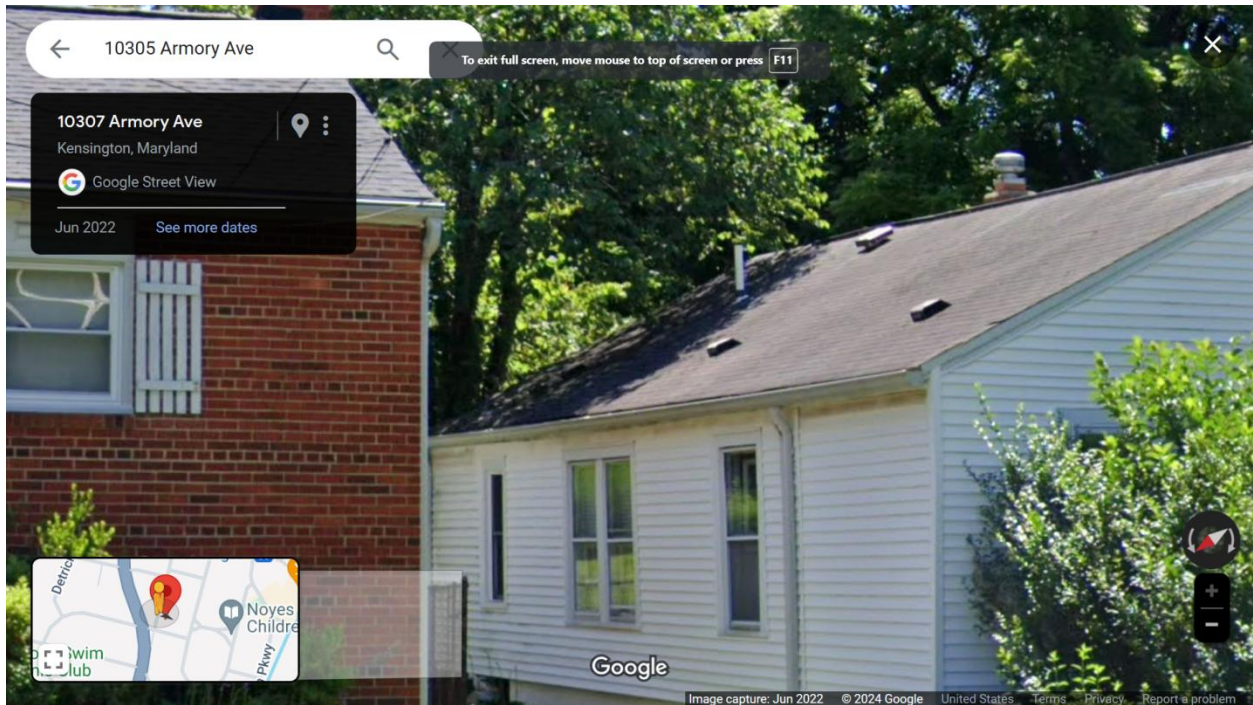

PROPOSED ROOF SHALL BE ARCHITECTURAL SHINGLES AS OPPOSED TO CURRENT 3 TAB SHINGLE.
(STYLE TBD) SIMILAR CHARCOAL COLORING. WITH RAISED ROOF SIMILAR ROOF VENTS SHALL BE USED
IN COORDINATION WITH RIDGE VENT (AS EXISTING) .

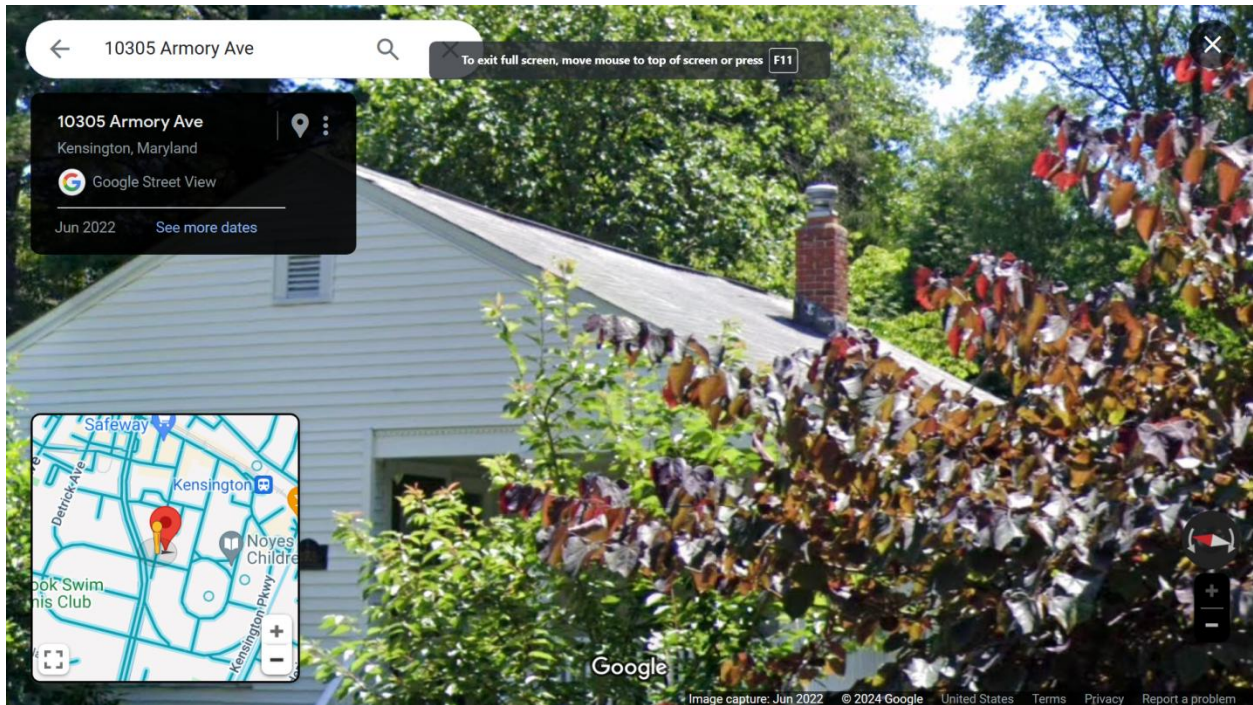

EXISTING CHIMNEY REMAINS BUT WILL BE DEMO'D IN THE INTERIOR AND STRUCTURALLY SUPPORTED
OWNER SHALL USE DIRECT VENT EQUIPMENT THAT WOULD VENT AND INTAKE AT SOUTH FACING
SIDE WALL ALONG DRIVEWAY SIDE

DRAINAGE- DRYWELL IS PROPOSED AT FRONT YARD ON PROPOSED SITE PLAN RECEIVING
STORMWATER FROM DOWNSPOUTS OF NEW ADDITION. NEW WELLS AND ADDITION FOUNDATION
WILL BE PIPED TO SUMP AND TERMINATED ALONG SOUTH SIDE OF HOUSE.

SW 7649
Silverplate

239-C5

PROPOSED SIDING FOR HOUSE AND GARAGE (WHITE TRIM TBD, FOUNDATION GREY TBD, LATTICE WHITE OR COLOR TBD), WHITE WINDOWS , WHITE GUTTERS , ARCHITECTURAL BLACK CHARCOAL SHINGLES PORCH CEILING COLOR TBD..



EXISTING REAR PAVERS TO BE BE REPURPOSED FOR NEW WALK FROM DRIVE TO DECK AND DETACHED GARAGE.

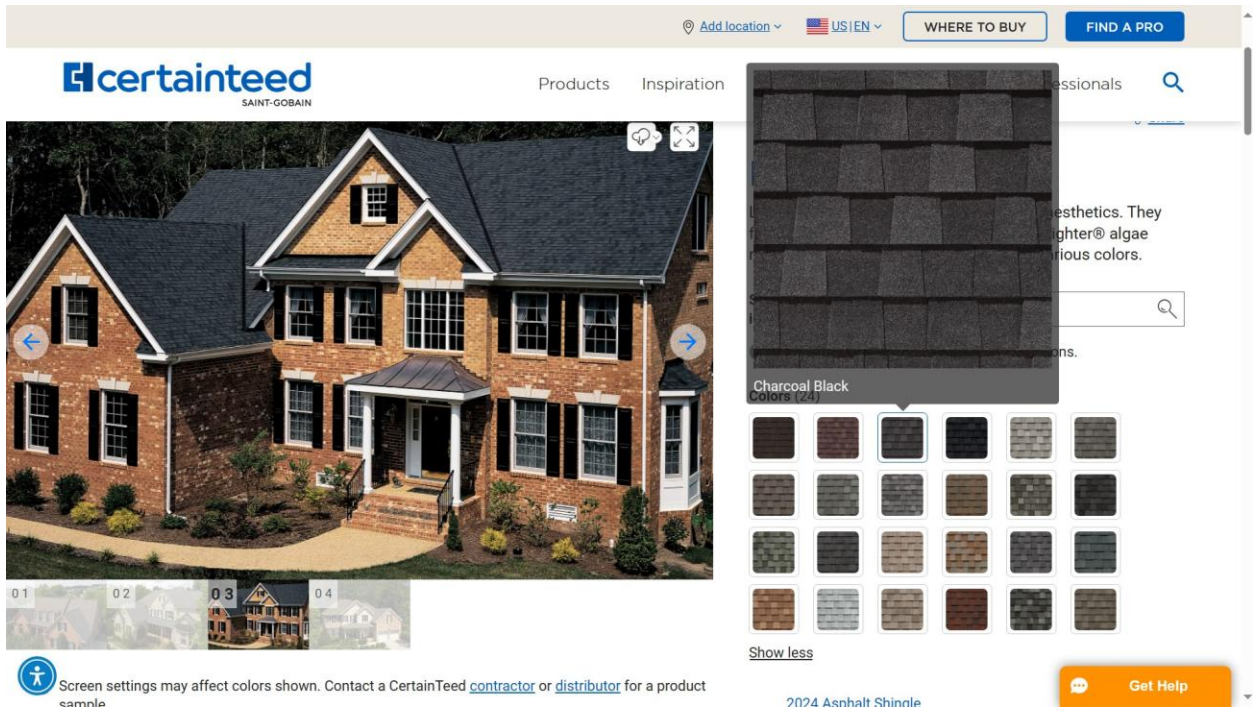

ARCHITECTURAL SHINGLES- CERTAINTED LANDMARK CHARCOAL BLACK

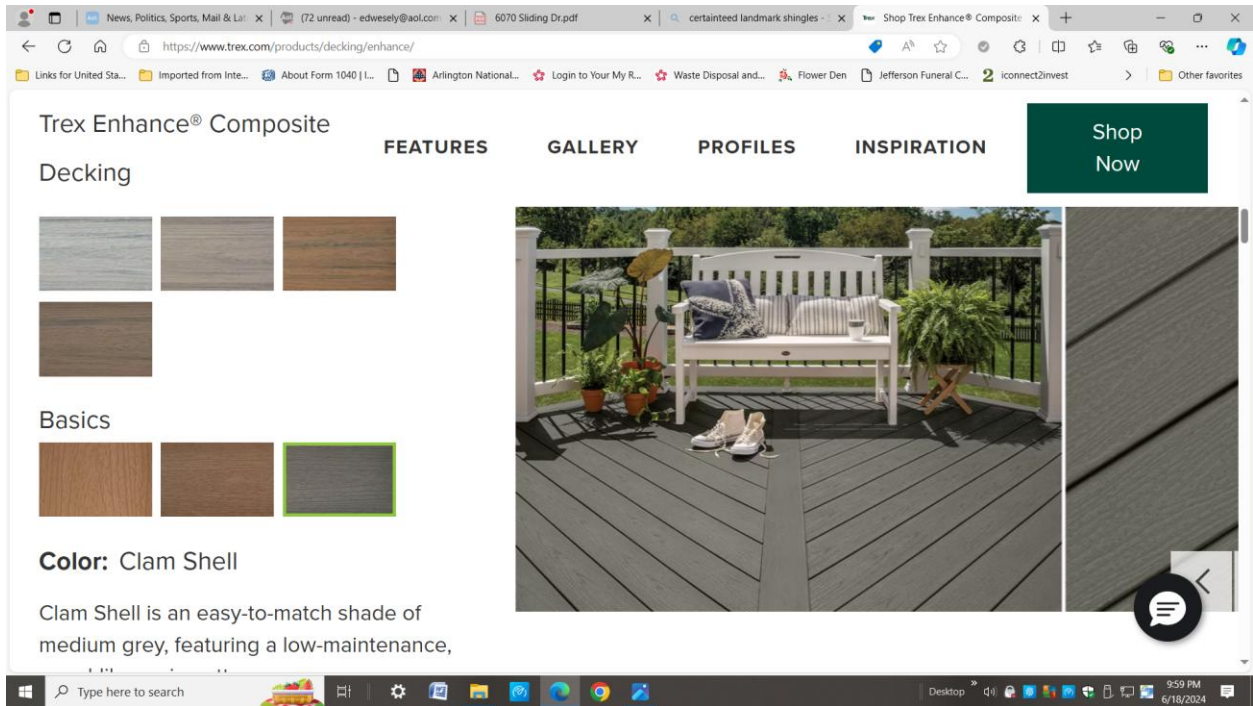

TREX DECKING - ENHANCE CLAMSHELL WITH CONCEALED FASTENERS. MATCHING FASCIA BOARD AT APRON

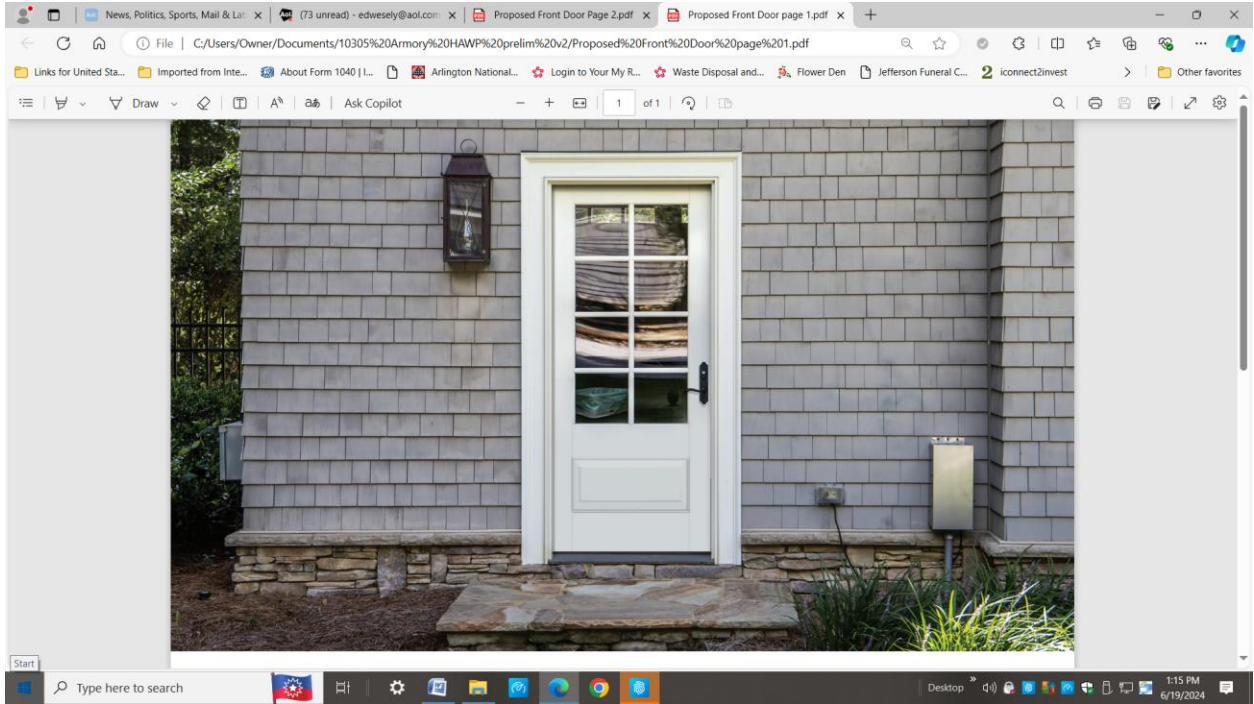

PROPOSED FRONT DOOR 12 LITE (3X4H) (NOT 8 LITE AS SHOWN) SIMPSON SASH DOORS 7/8" SDL Bar & 1-7/16" DOUBLE HIP RAISED PANEL

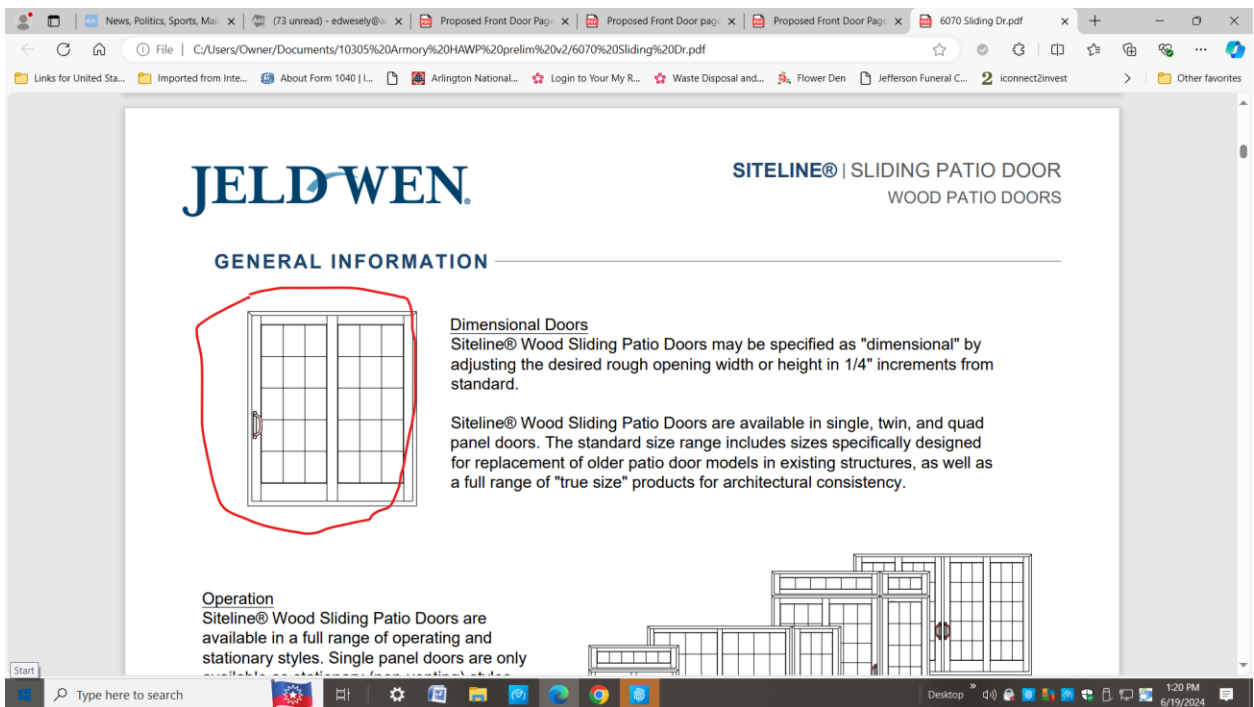

PROPOSED REAR SLIDING DOOR JELD WEN SITELINE WOOD SLIDING PATIO

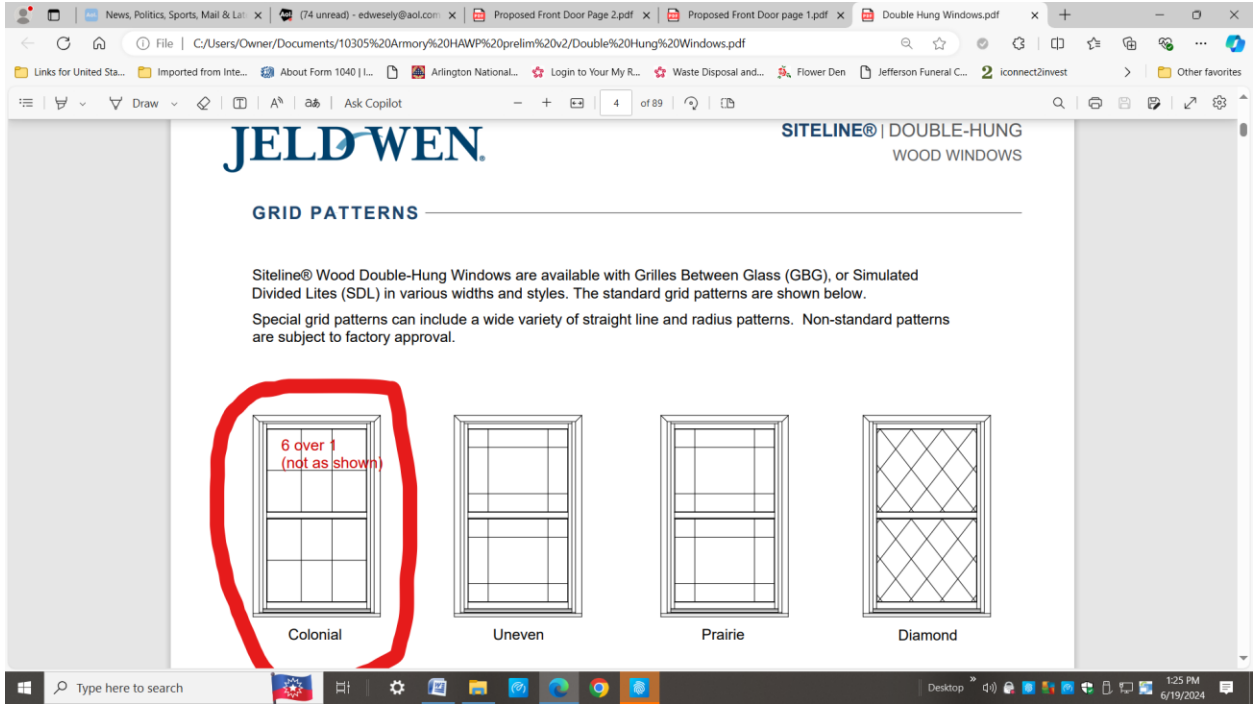

PROPOSED JELD WEN SITELINE DOUBLE HUNG WOOD WINDOW

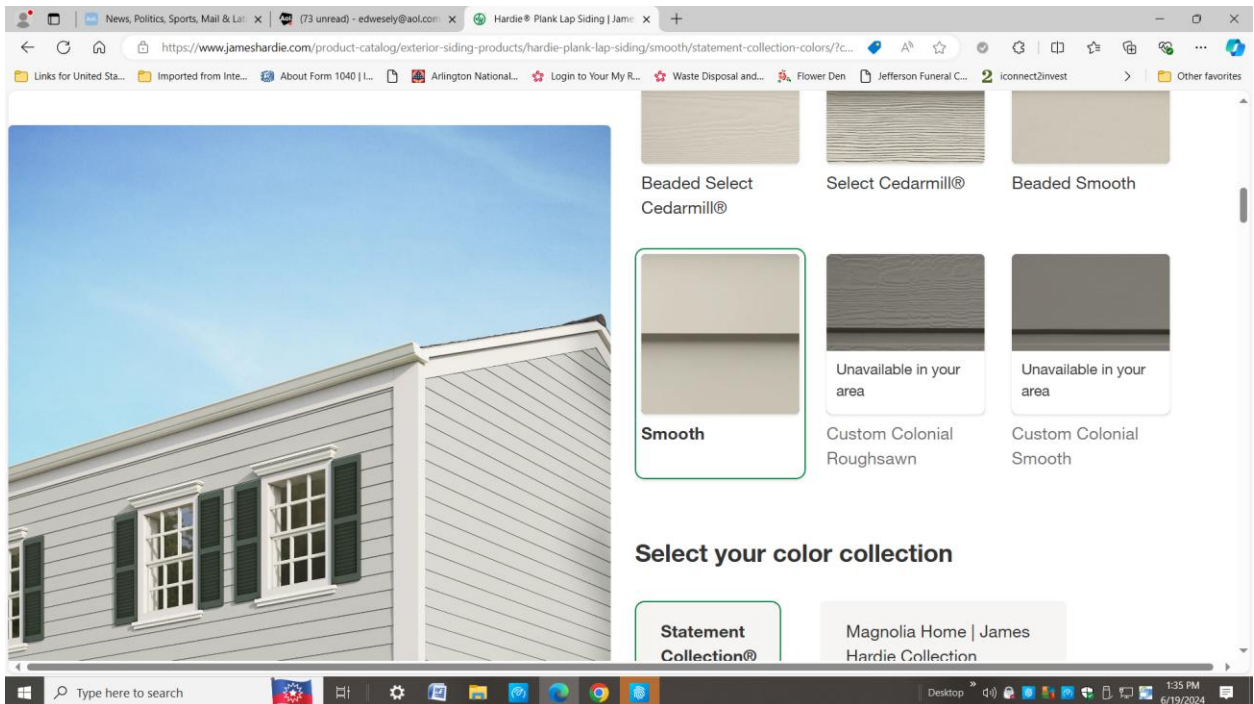

PROPOSED LAP SIDING FOR ADDITION 8.25 OVERLAPPED TO 7" EXPOSED. COMPOSITE TRIM TO BE USED AT ADDITION.

NEW OUTDOOR LIGHT FIXTURES TBD.

Historic Preservation Commission Preliminary Consultation Report

Address: 10305 Armory Avenue, Kensington

Applicant(s): Village Concrete

Proposal: Demolition, two-story rear addition, and various alterations.

Staff Contact: Chris Berger

HPC Commissioners Providing Comments: Karen Burditt (Acting Chair), Jeffrey Hains (Acting Vice Chair), James Doman, Cristina Radu, Zara Naser, and Mark Dominianni

Recommendations

The HPC stated the following:

- Review the abiding regulations before embarking on this project. These include the *Approved & Adopted Amendment to the Master Plan for Historic Preservation: Kensington Historic District, Atlas #31/6; Vision of Kensington: A Long-Range Preservation Plan; Montgomery County Code Chapter 24A; and the Secretary of the Interior's Standards for Rehabilitation.*
- The plans would require significant revision in order for the HPC to support.
- NEW OFFSET ● Provide proof that the footprint meets the setback requirements.
 - Hire an architect well versed in the Commission's requirements.
- The addition as proposed overwhelms the existing building, and they do not integrate well.
- The massing should be more proportional to the existing building.
 - If the addition is two stories, the height should be decreased and dormers constructed for additional headroom.
- Consider a one-story addition.
- Some may support replacement of windows with additional documentation they are beyond repair.
- The gable of the existing and addition should be the same direction.
- The Commission is unlikely to support raising the roof.
- Look to houses in the Takoma Park Historic District for examples on how to expand small homes in an historic district.
- The project would require at least one additional Preliminary Consultation followed by an Historic Area Work Permit review.
- The applicant should return with a more detailed drawings for the next submission.

Staff opposed the following alterations to the existing building:

- Replace the wood porch floor and stairs with composite.
- Raise the existing roof height 1 foot.
- Remove the chimney.
- Add a 1-foot wide eave on the front elevation.
- Infill two windows and enlarge 4 windows on the right-side elevation.
- Install wood windows on the front elevation.
- Install composite windows on the side elevations.

Staff supported the following alterations to the existing building:

- Remove rear elevation to build a rear addition.
- Replace the 3-tab shingles with architectural-grade shingles.
- Replace vinyl siding with wood siding.
- Add new downspout.
- Replace front door.

- • Remove storm windows.
- • Install two window wells on right-side.

Staff opposed the following proposed for the addition:

- • Size, scale, and architectural features.
- • Building height.
- • Front-oriented roof.
- • Randomly spaced window openings.
- • Composite windows.

Staff supported the following proposed for the addition:

- • Pitch of the addition's roof and its covering with architectural grade shingles.
- • The wider roof overhangs compared to existing residence.
- • Sliding door on the new rear elevation.
- • Wood siding, as long as it doesn't match existing residence.
- • 12-by-20 pressure-treated wood deck with Trex flooring and composite railing.

PROPOSING
HARDIE PLANK

Staff supported the following proposed the following changes to the hardscaping and landscaping:

- • Remove brick patio.
- REMOVED ● • Install areaway with concrete pad along new addition.
- 2 ● • Remove three trees. Arborist report should be provided.
- SEE SITE PLAN ● • Shift curb cut and install a new 11-foot wide concrete driveway with parking pad next to the existing outbuilding. Staff encourages a reduced width driveway.
- • Lay stone pavers between driveway and proposed deck.
- • Remove 4-foot tall fence segment in side yard.
- • Install HVAC units.

Staff recommends the following be included in the next Preliminary Consultation:

- • Higher resolution drawings.
- • Proposed changes to the site described in a single narrative.
- • Finalize the size of the addition and drainage before submitting revised plans for the next preliminary consultation.
- • Detailed drawings for proposed features such as the areaway, deck, and window wells.
- • A window and door schedule that corresponds to the elevations.
- NOT COMPLETE ● • Specification sheets for all proposed building features, including the doors, windows, siding, trim, roofing, deck flooring; railings; hardscaping, lighting, and gutters and downspouts.
- DECIDED TO RETAIN EXSTING ● • Photos and a statement on the material, design, and condition of the cladding, or lack thereof, underneath the existing vinyl siding.
- • A comment response sheet that describes how each HPC recommendation was addressed.
- • Provide an arborist's report for the three trees to be removed.

Return for an additional preliminary consultation

Return for a HAWP in accordance with the Commission's recommendations



SITELINE® | DOUBLE-HUNG

WOOD WINDOWS

ARCHITECTURAL DESIGN MANUAL | May 2024

TABLE OF CONTENTS

PRODUCT INFORMATION

GENERAL INFORMATION	3
GRID PATTERNS	4
CLEAR OPENING LAYOUT	5
GRID, BOTTOM RAIL & GLASS STOP OPTIONS	6
UNIT SIZING	7
TRIM & SILL NOSE OPTIONS	8
JAMB EXTENDER & PREP FOR STOOL OPTIONS	9
MULLION OPTIONS	10

SECTION DETAILS

OPERATOR SECTIONS - STANDARD	12
OPEARTOR SECTIONS - RADIUS TOP / SEGMENT HEAD	13
FIXED SECTIONS - STANDARD	14
FIXED SECTIONS -RADIUS TOP / SEGMENT HEAD	15
TRANSOM SECTIONS	16
BAY STANDARD SECTIONS	17
BAY STANDARD PROJECTIONS	18

ELEVATION DETAILS

MIN-MAX STANDARD SIZING	19
FORMULAS	21
EGRESS CHARTS	22
COTTAGE VENT LAYOUTS	23
STANDARD UNITS	
RECTANGLE	24
EXTENDED CIRCLE SEGMENT	30
EXTENDED QUARTER SEGMENT	36
EXTENDED HALF ROUND	42
FIXED UNITS	
RECTANGLE	46
EXTENDED CIRCLE SEGMENT	58
EXTENDED QUARTER SEGMENT	70
EXTENDED HALF ROUND	82

GENERAL INFORMATION

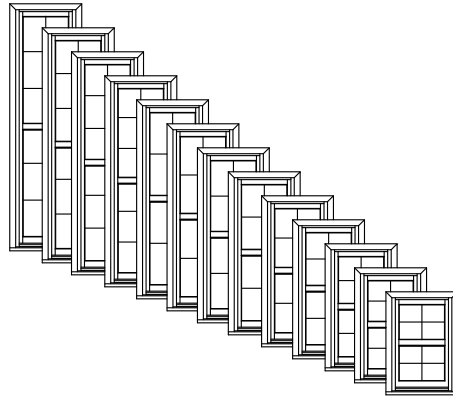

Dimensional Windows

Siteline® Wood Double-Hung windows may be specified as "dimensional", by adjusting the desired rough opening width or height. Siteline® Wood Double-Hung windows feature fully operating upper and lower sash which can be tilted or removed for easy cleaning.

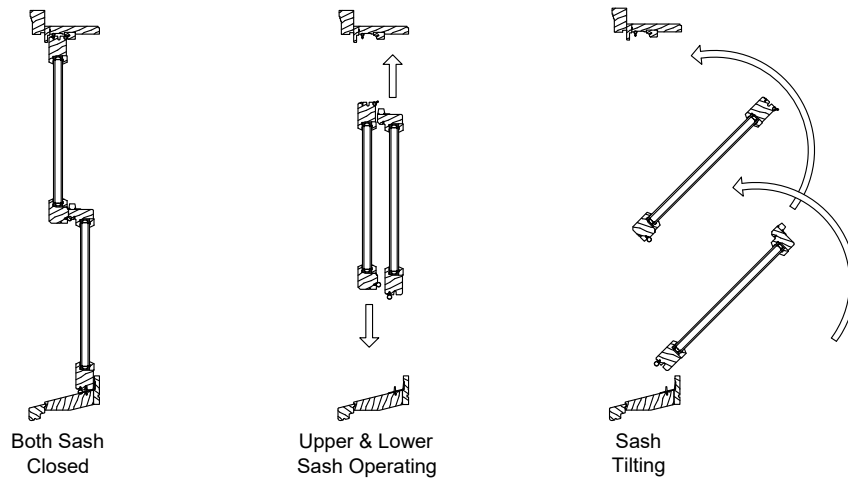

Multiple Assemblies

Siteline® Wood Double-Hung windows may be mulled beside other wood double-hung windows or to other wood window products to fulfill a wide variety of architectural design needs.

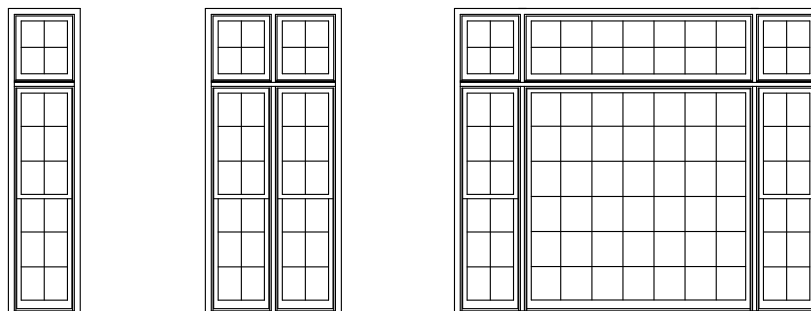

GRID PATTERNS

Siteline® Wood Double-Hung Windows are available with Grilles Between Glass (GBG), or Simulated Divided Lites (SDL) in various widths and styles. The standard grid patterns are shown below.

Special grid patterns can include a wide variety of straight line and radius patterns. Non-standard patterns are subject to factory approval.

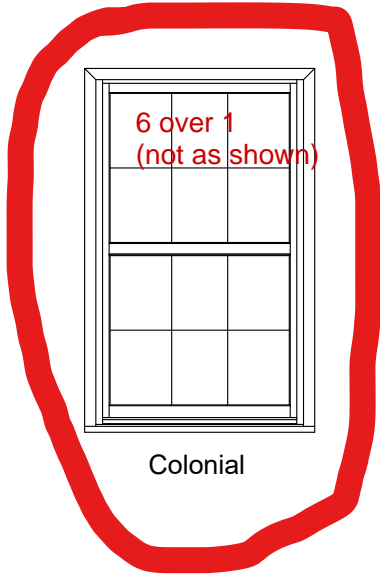

Colonial

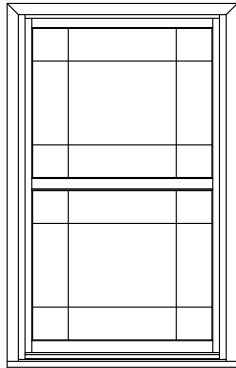

Uneven

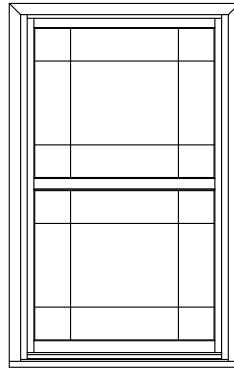

Prairie

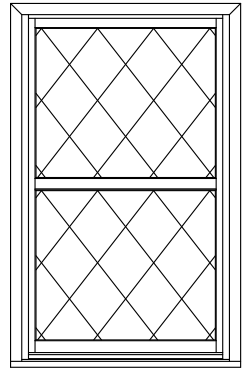

Diamond

Bar Alignment

Alignment of bars from product to product is often required. SDL, GBG, and wood grilles may be specified with bars aligned.

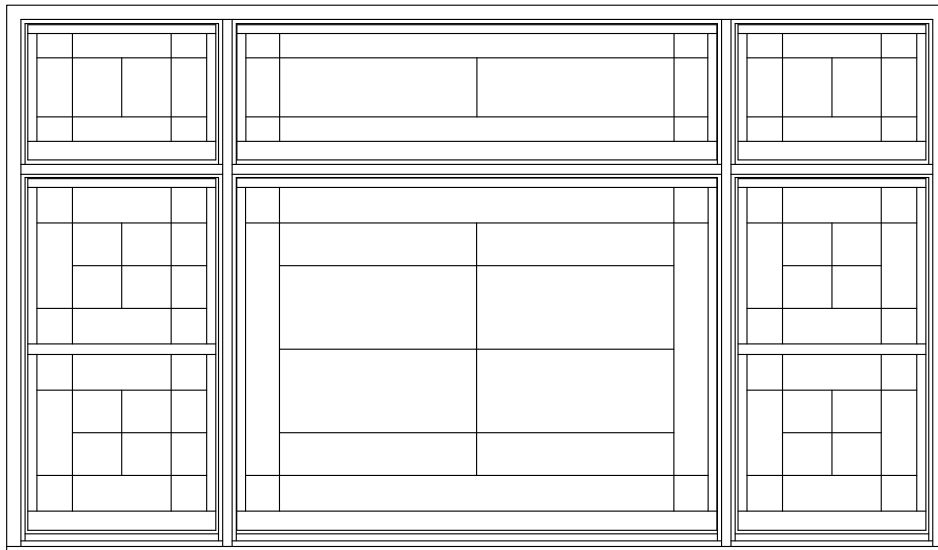

CLEAR OPENING LAYOUT

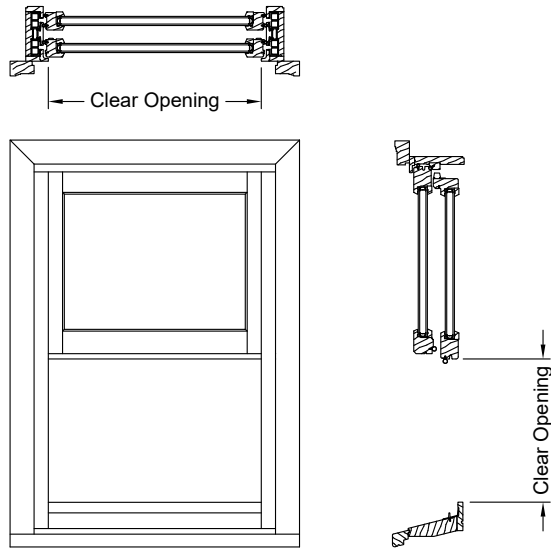

Double-Hung (Even Divide)
 Width = Frame Width - 3 3/4"
 Height = (Frame Height / 2) - 2 27/32"

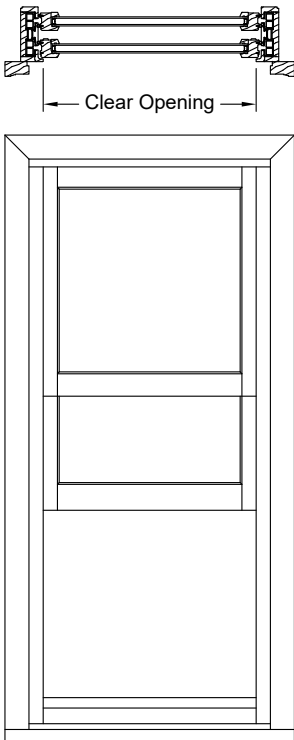

Cottage Double-Hung
 Width = Frame Width - 3 3/4"
 Height = (Frame Height / 2) - 8 5/32"

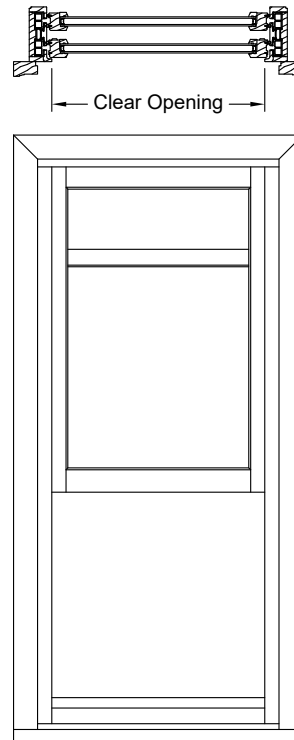

Reverse Cottage Double-Hung
 Width = Frame Width - 3 3/4"
 Height = (Frame Height / 2) - 7 29/32"

GRID, BOTTOM RAIL & GLASS STOP OPTIONS

Exterior ← → Interior

SDL Options

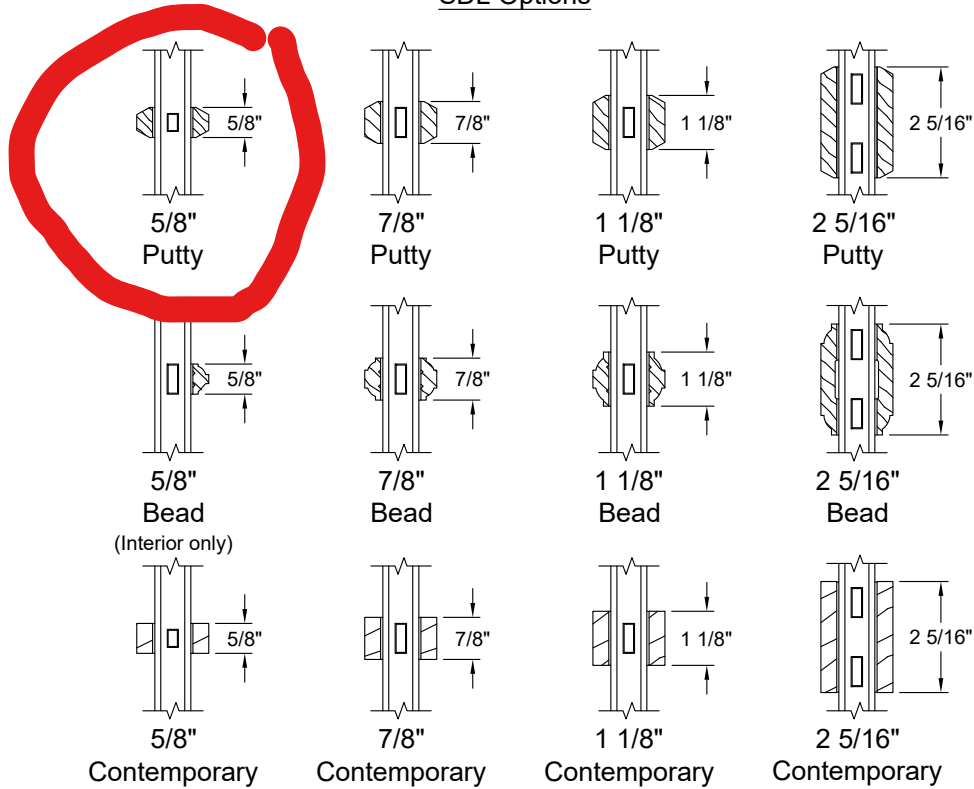

Note: Various Combinations of the SDL Bars Shown are Available

GBG Options

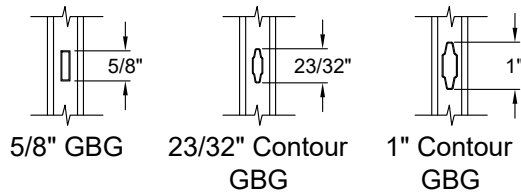
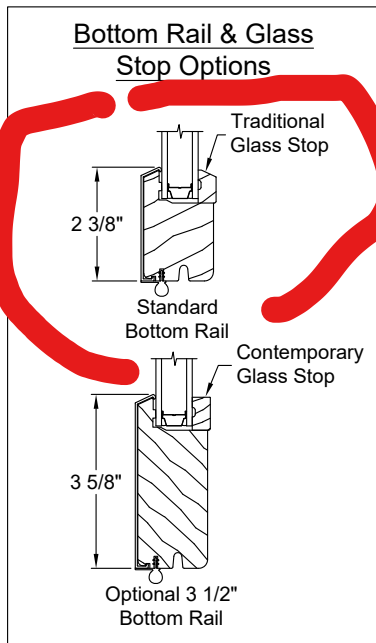

UNIT SIZING

Rough Opening

The frame size of the window plus 3/4".

Masonry Opening

The overall size of the window, including trim, plus 1/2".

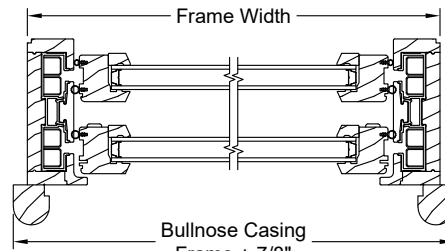

Trim - 4 Sides Of Unit

When applied to 4 sides of unit, these dimensions apply to both vertical and horizontal window sections.

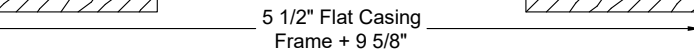
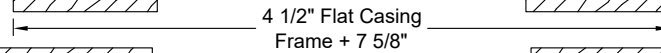
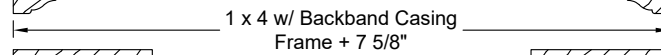
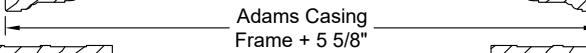
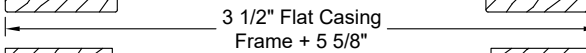
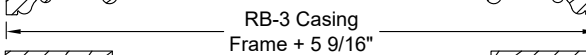
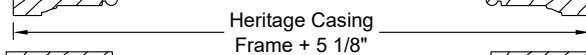
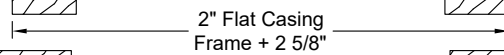
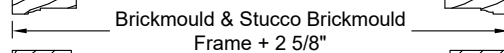
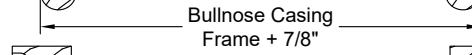

Trim - 3 Sides of Unit

When applied to 3 sides of unit, with Standard Sill Nose, these dimensions apply to vertical window sections only.

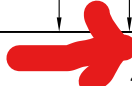
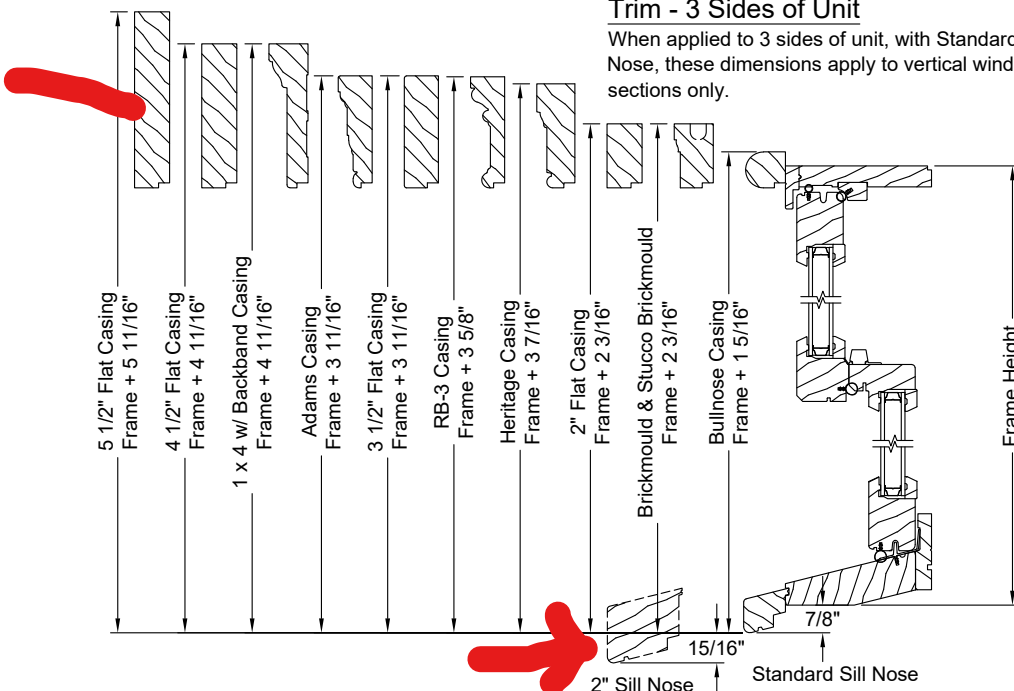

TRIM & SILL NOSE OPTIONS

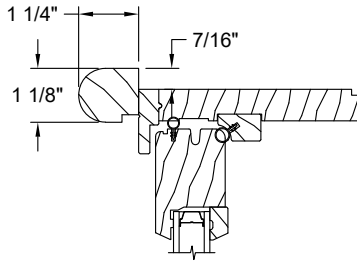

Bullnose Casing

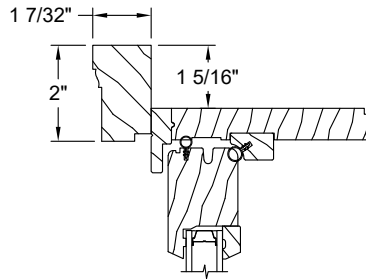

Brickmould

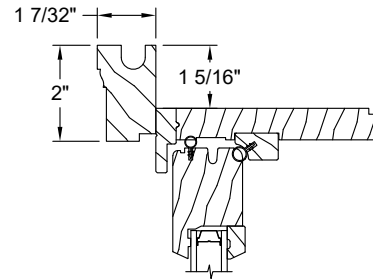

Stucco Brickmould

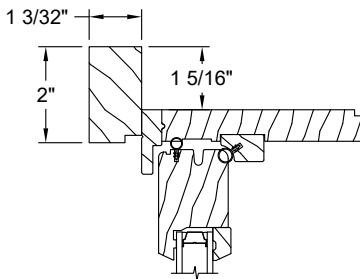

2" Flat Casing

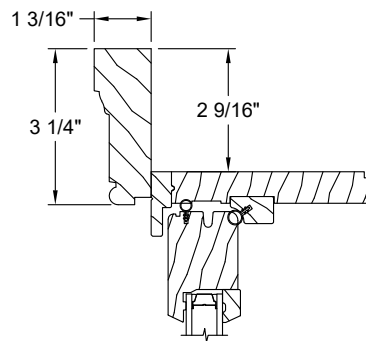

Heritage Casing

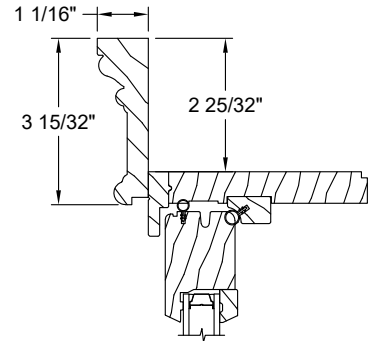

RB-3 Casing

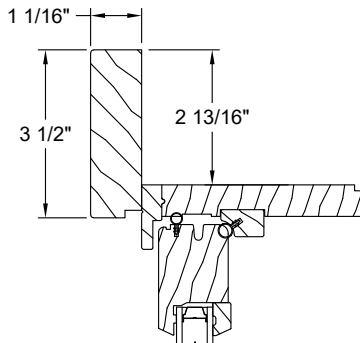

3 1/2" Flat Casing

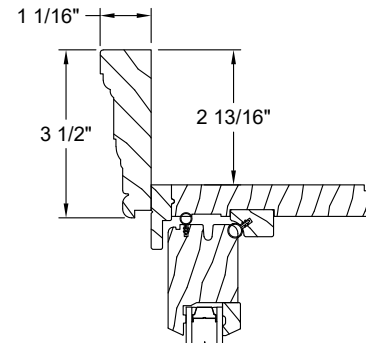

Adams Casing

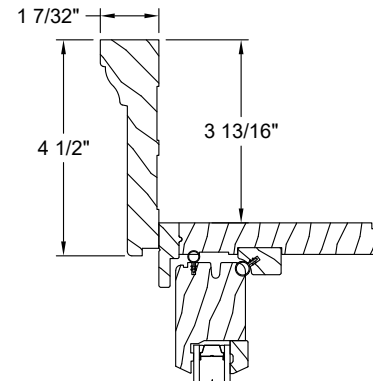

1 x 4 w/ Backband Casing

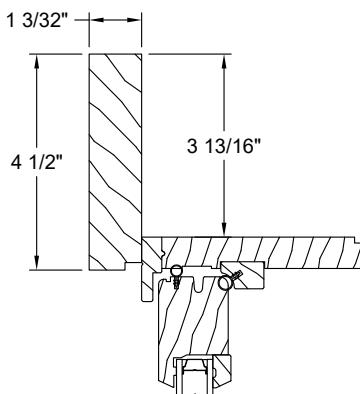

4 1/2" Casing

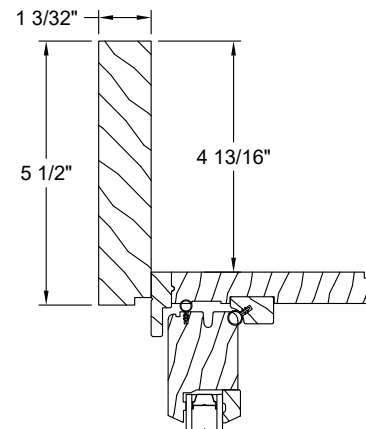

5 1/2" Casing

Sill Nose Options

Standard Sill Nose

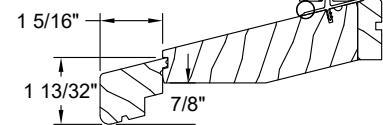

2" Sill Nose

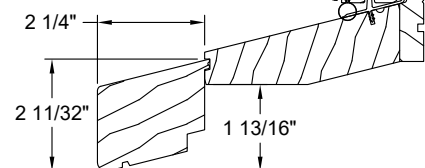

JAMB EXTENDER & PREP FOR STOOL OPTIONS

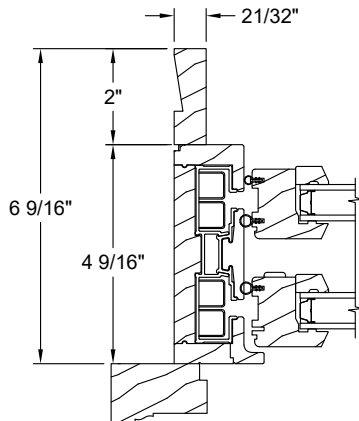

6 9/16" Jamb Width
4/4 Jamb Thickness

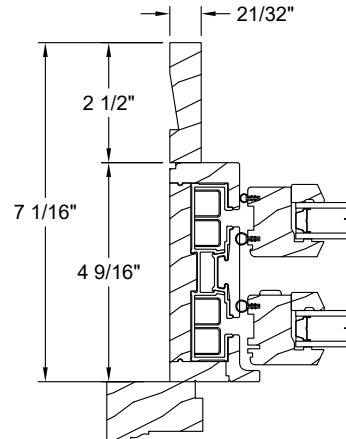

7 1/16" Jamb Width
4/4 Jamb Thickness

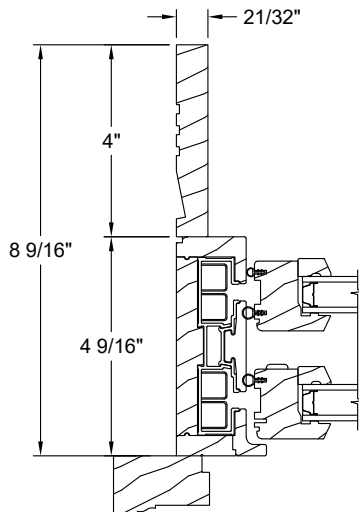

8 9/16" Jamb Width
4/4 Jamb Thickness

Return Kerf:

Generally located from first visible interior frame line. Kerfed option available on all jamb extender sizes.

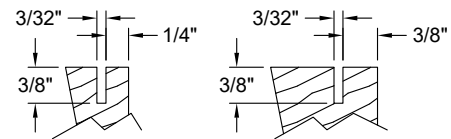

4/4 Jamb Typ.

5/4 Jamb Typ.

Prep for Stool

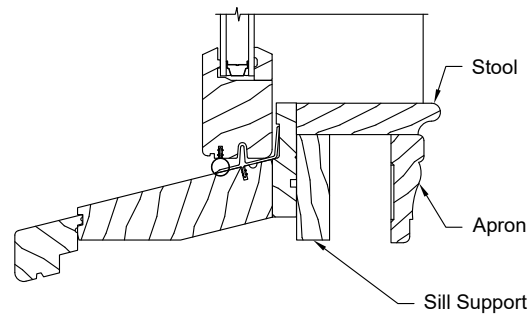

Stool, apron, and sill support are applied by trim carpenter after window is installed and are not provided by JELD-WEN. Unit is shipped without sill jamb extenders.

MULLION OPTIONS

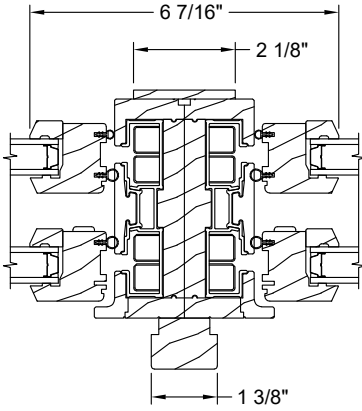

Operator | Operator

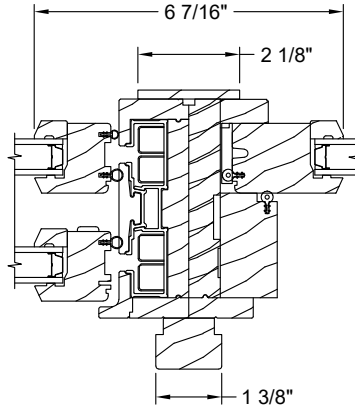

Operator | Stationary

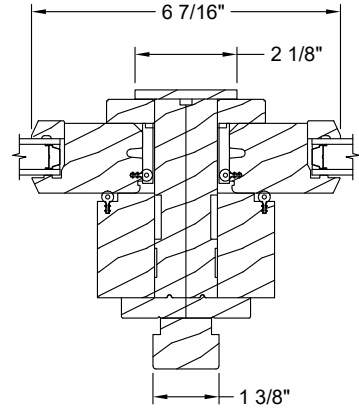

Stationary | Stationary

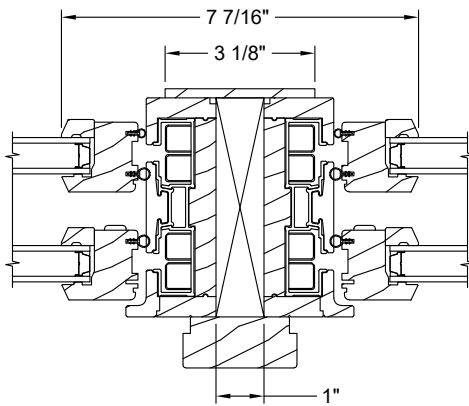

Operator | Operator
with 1" Solid Spread Mull

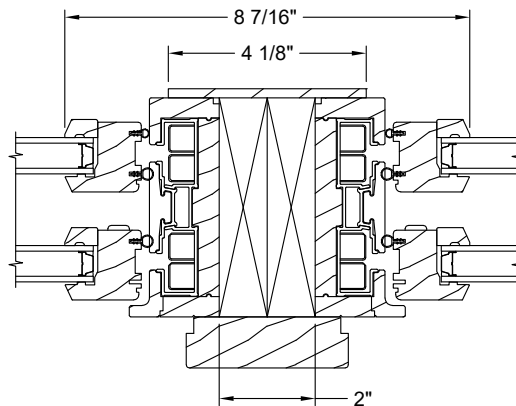

Operator | Operator
with 2" Solid Spread Mull

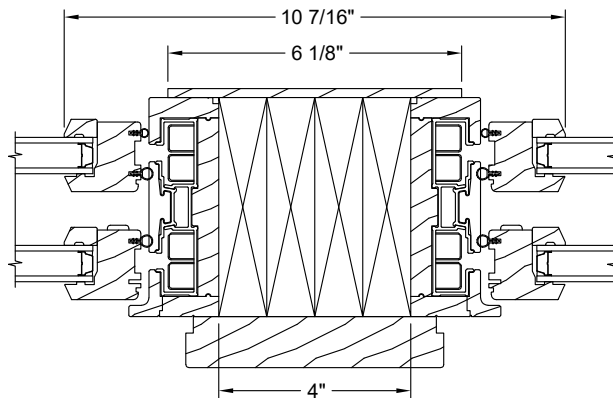

Operator | Operator
with 4" Solid Spread Mull

MULLION OPTIONS

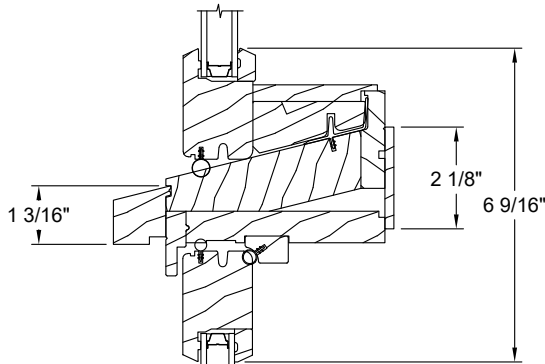

Transom
Operator

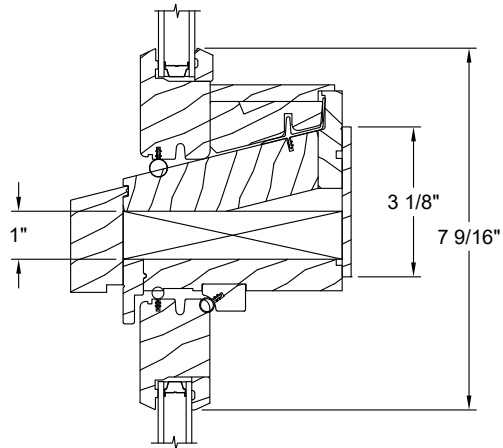

Transom
Operator
With 1" Solid Spread Mull

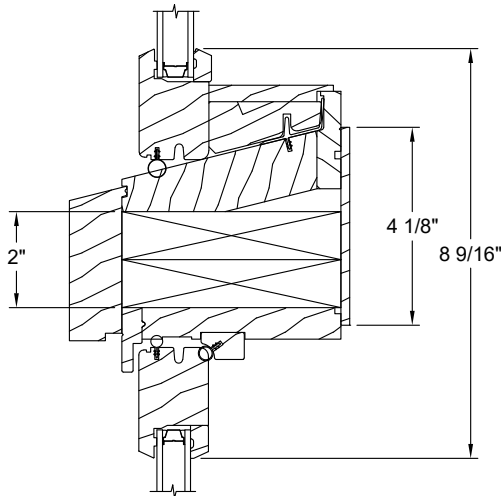

Transom
Operator
With 2" Solid Spread Mull

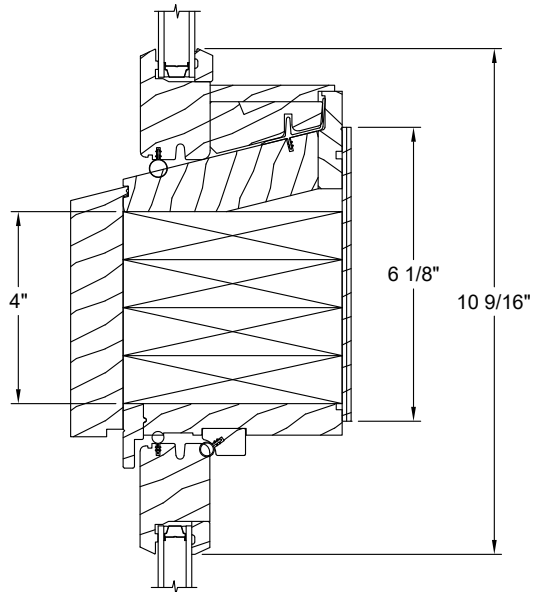

Transom
Operator
With 4" Solid Spread Mull

OPERATOR SECTIONS - STANDARD

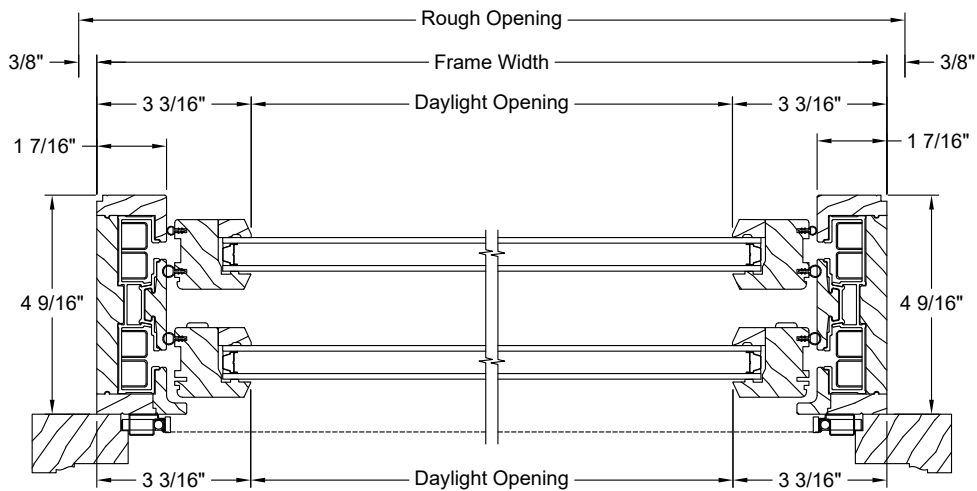
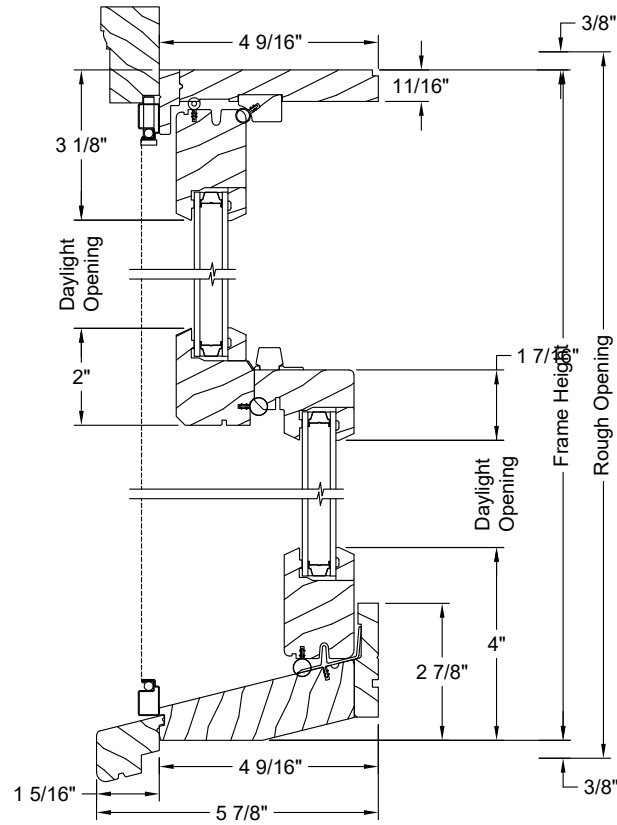
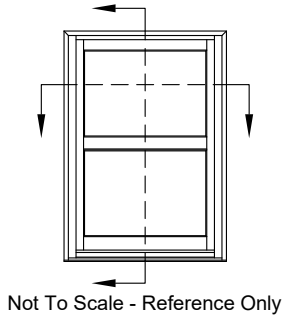

OPERATOR SECTIONS - RADIUS TOP / SEGMENT HEAD

Operator Radius-Top

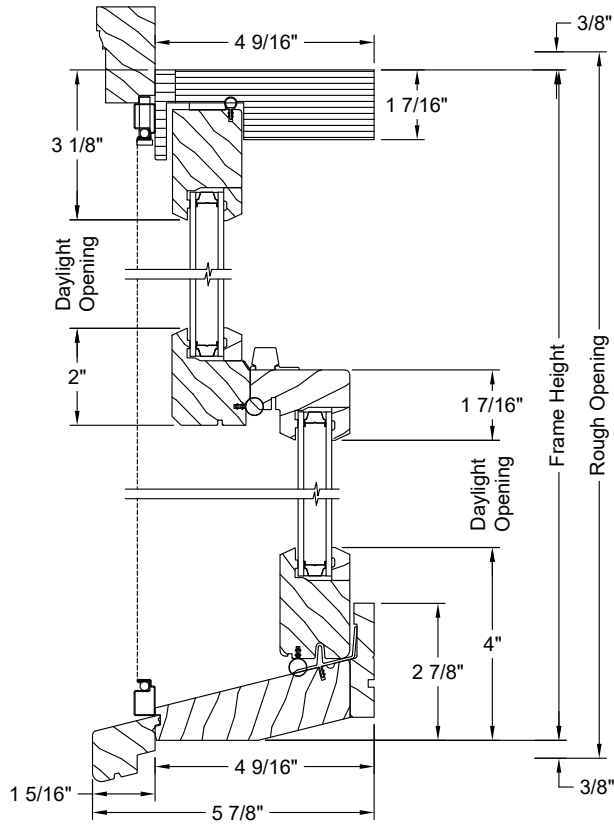

Operator Segment Head

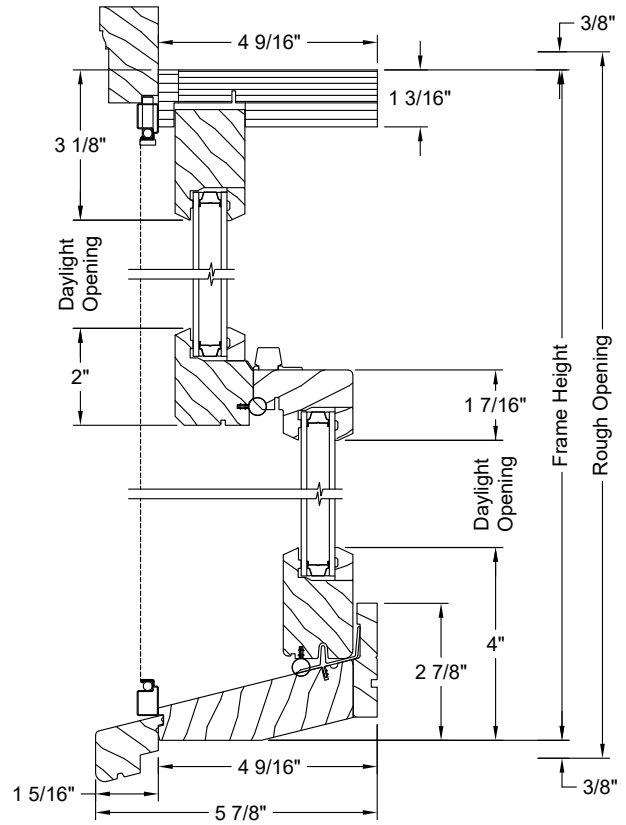

FIXED SECTIONS - STANDARD

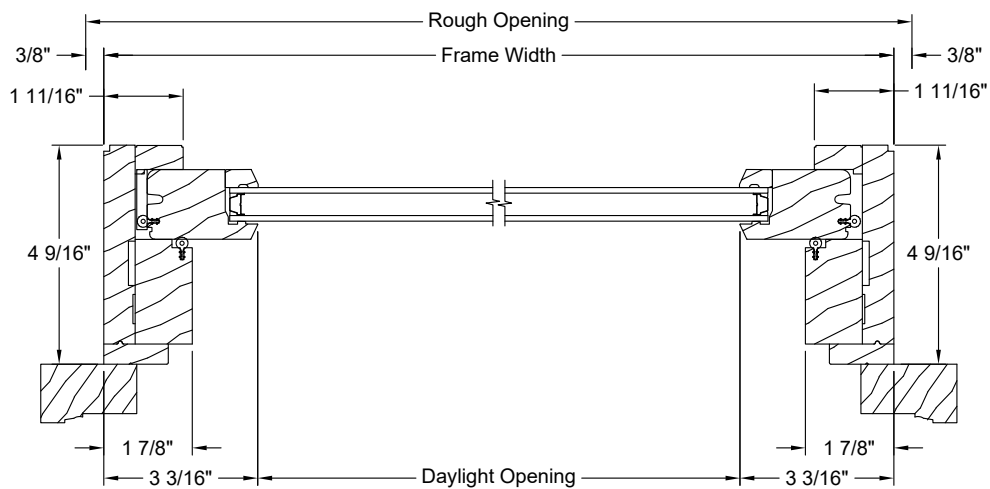
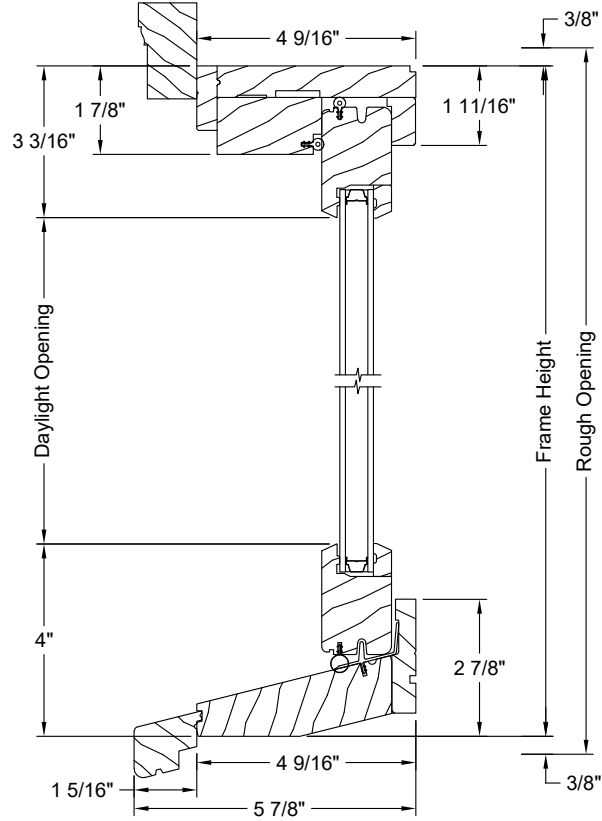
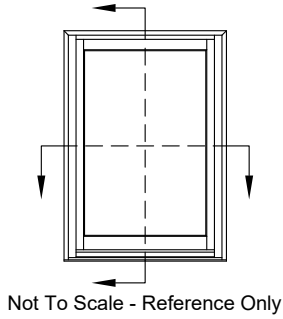

FIXED SECTIONS - RADIUS TOP / SEGMENT HEAD

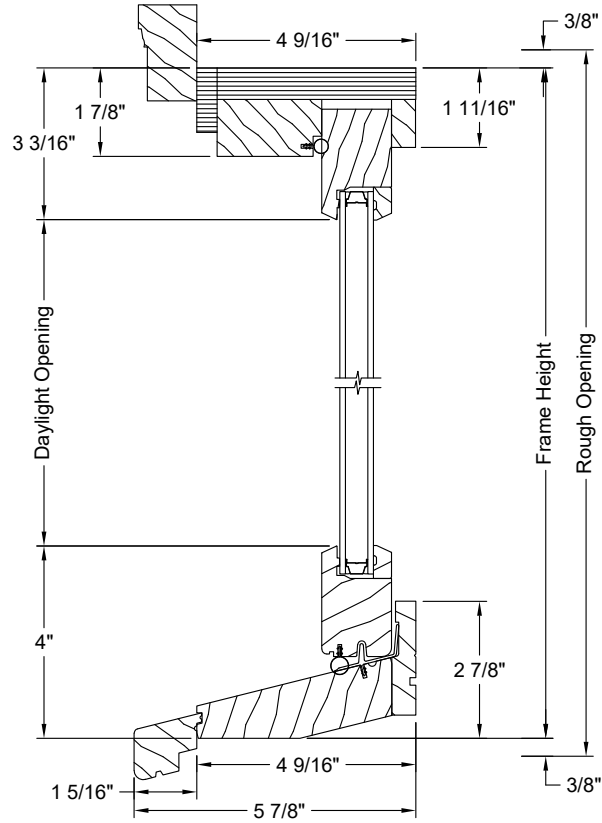
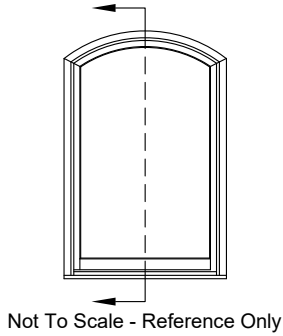

Picture Radius-Top & Picture Segment Head have the same cross-section.

BAY - STANDARD SECTIONS

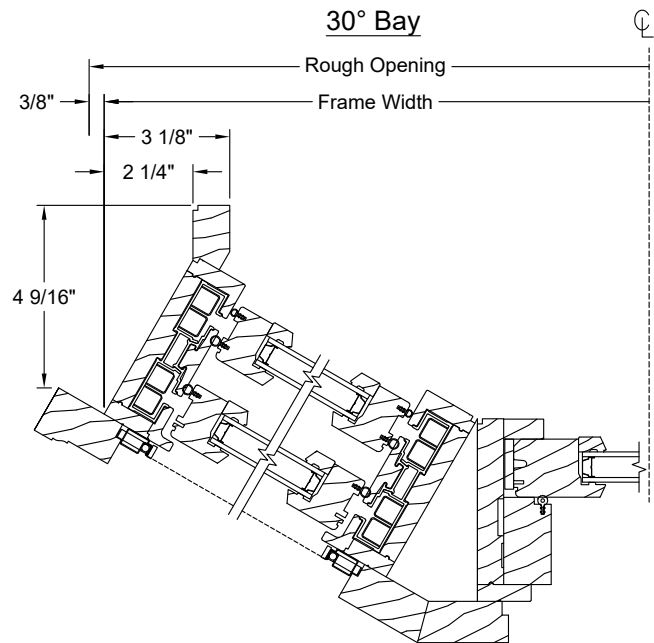
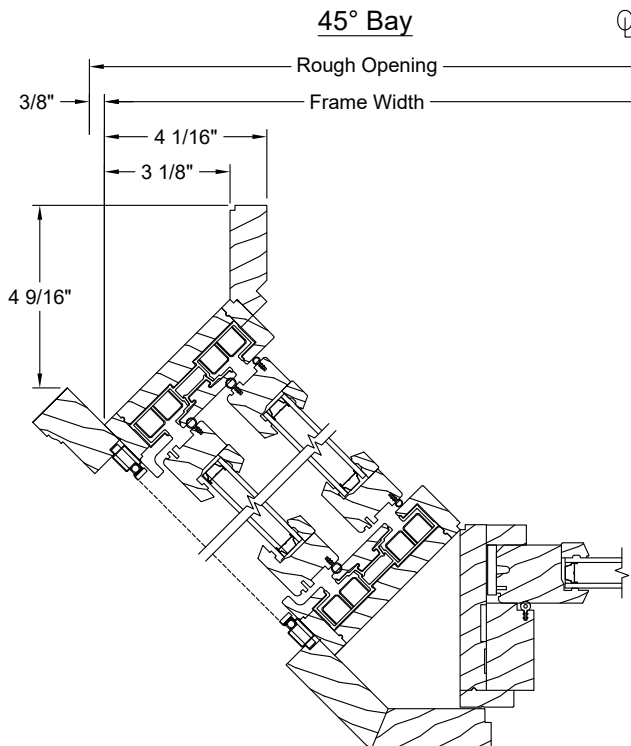
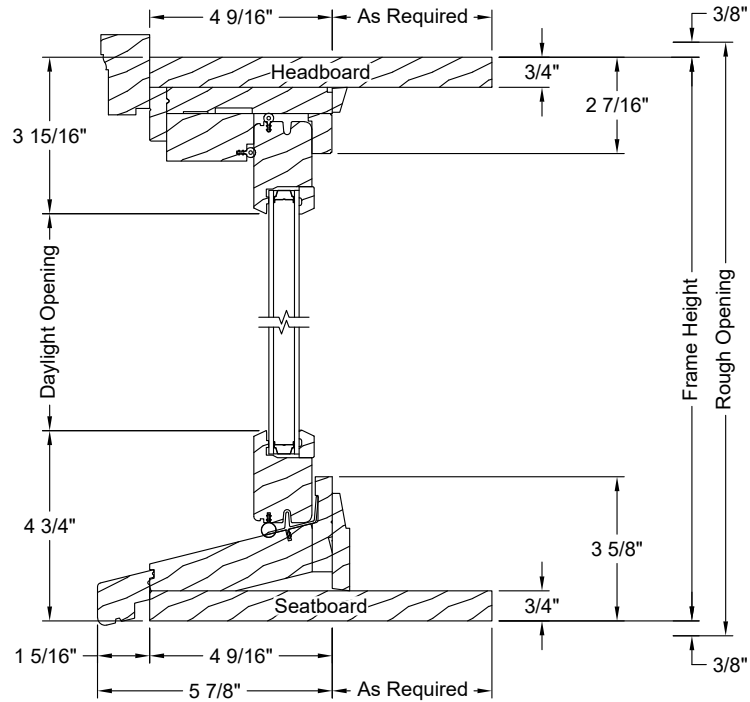

Horizontal views are symmetrical across centerline.

BAY - STANDARD PROJECTIONS

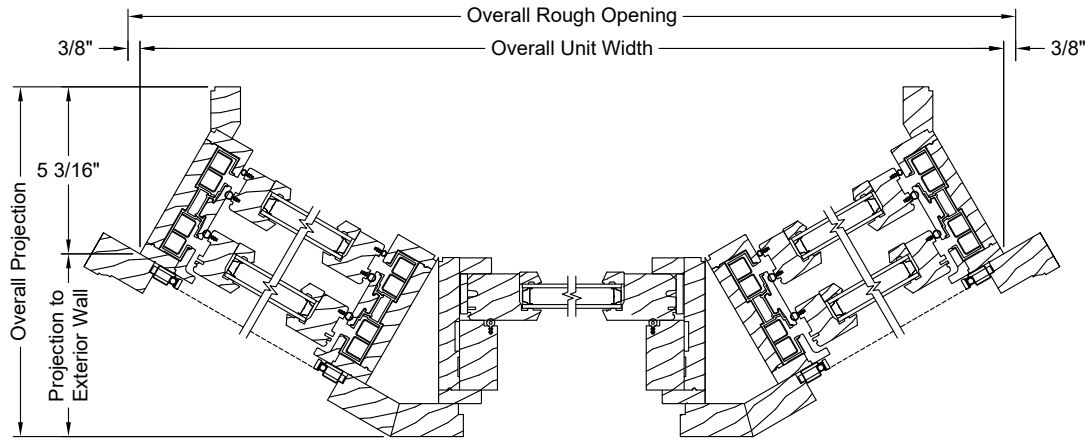

30° Bay				
Flanker Width	Overall Unit Width*	Overall Rough Opening*	Projection to Exterior Wall	Overall Projection
21 3/8"	85 5/8"	86 3/8"	11 5/16"	16 1/2"
25 3/8"	92 9/16"	93 5/16"	13 5/16"	18 1/2"
29 3/8"	99 1/2"	100 1/4"	15 5/16"	20 1/2"
31 3/8"	102 15/16"	103 11/16"	16 5/16"	21 1/2"
33 3/8"	106 7/16"	107 3/16"	17 5/16"	22 1/2"
37 3/8"	113 3/8"	114 1/8"	19 5/16"	24 1/2"
41 3/8"	120 5/16"	121 1/16"	21 5/16"	26 1/2"
45 3/8"	127 3/16"	127 15/16"	23 5/16"	28 1/2"
45° Bay				
Frame Width	Overall Unit Width*	Overall Rough Opening*	Projection to Exterior Wall	Overall Projection
21 3/8"	80 3/4"	81 1/2"	16 7/16"	21 15/16"
25 3/8"	86 3/8"	87 1/8"	19 1/4"	24 3/4"
29 3/8"	92 1/16"	92 13/16"	22 1/8"	27 5/8"
31 3/8"	94 7/8"	95 5/8"	23 1/2"	29"
33 3/8"	97 11/16"	98 7/16"	24 15/16"	30 7/16"
37 3/8"	103 3/8"	104 1/8"	27 3/4"	33 1/4"
41 3/8"	109"	109 3/4"	30 9/16"	36 1/16"
45 3/8"	114 11/16"	115 7/16"	33 7/16"	38 15/16"

30° bay shown for reference only.

Table values calculated using 4 9/16" jamb depths and standard nail fin.

* Overall Unit Width and Overall Rough Opening calculated using a 44 1/16" Center Frame Width. To calculate the values with a different Center Frame Width, add the difference of the Center Frame Widths to the overall width values.

MIN-MAX STANDARD SIZING

Operator Rectangle Units

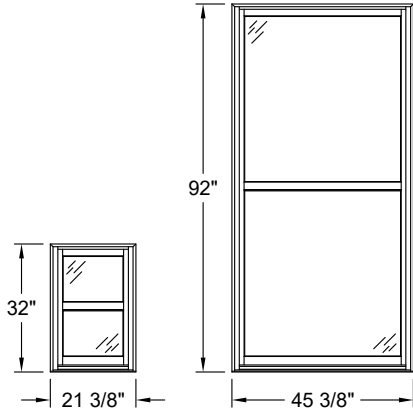

Minimum Size: 21 3/8" x 32"
Maximum Size: 45 3/8" x 92"

Standard Widths				
21 3/8"	25 3/8"	29 3/8"	31 3/8"	33 3/8"
35 3/8"	37 3/8"	41 3/8"	45 3/8"	

Standard Heights				
32"	36"	40"	44"	48"
52"	56"	60"	64"	68"
72"	76"	80"	88"	92"

Stationary Rectangle Units

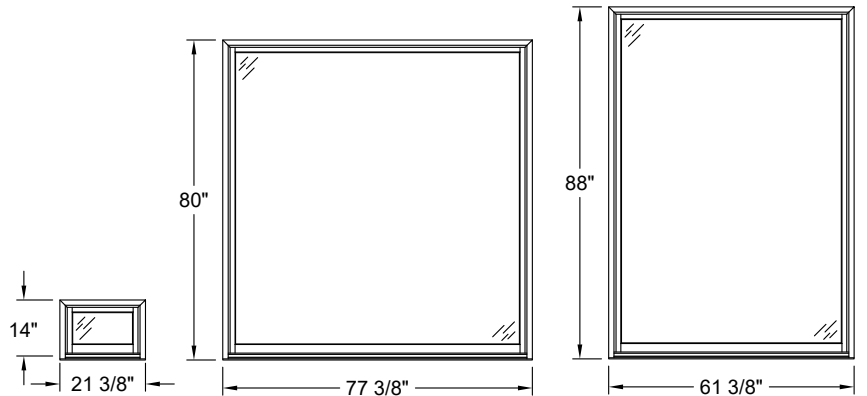

Minimum Size: 21 3/8" x 14"
Maximum Width Size: 77 3/8" x 80"
Maximum Height Size: 61 3/8" x 88"

Standard Widths						
21 3/8"	25 3/8"	29 3/8"	31 3/8"	33 3/8"	35 3/8"	37 3/8"
41 3/8"	45 3/8"	49 3/8"	53 3/8"	61 3/8"	69 3/8"	77 3/8"

Standard Heights						
15"	18"	24"	32"	36"	40"	44"
48"	52"	56"	60"	64"	68"	72"
76"	80"	88"				

Operator Extended Circle Segment Units

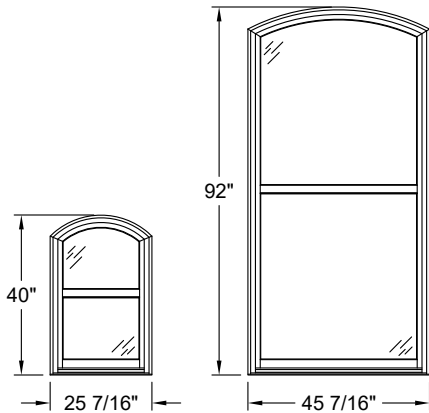

Minimum Size: 25 3/8" x 40"
Maximum Size: 45 3/8" x 92"

Standard Widths				
25 3/8"	29 3/8"	31 3/8"	33 3/8"	35 3/8"
37 3/8"	41 3/8"	45 3/8"		

Standard Heights				
40"	44"	48"	52"	56"
60"	64"	68"	72"	76"
80"	88"	92"		

Fixed Extended Circle Segment Units

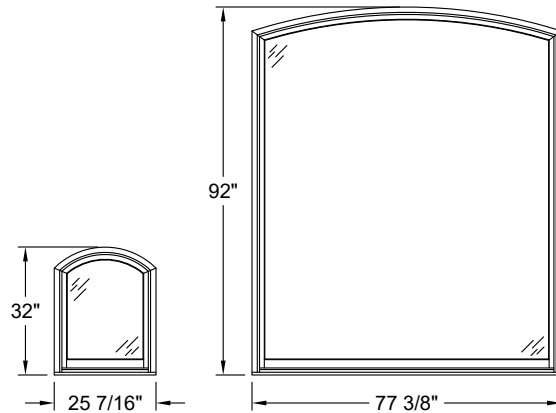

Minimum Size: 25 3/8" x 32"
Maximum Size: 77 3/8" x 92"

Standard Widths						
25 3/8"	29 3/8"	31 3/8"	33 3/8"	37 3/8"	41 3/8"	45 3/8"
49 3/8"	53 3/8"	61 3/8"	69 3/8"	77 3/8"		

Standard Heights						
32"	36"	40"	44"	48"	52"	56"
60"	64"	68"	72"	76"	80"	88"
92"						

MIN-MAX STANDARD SIZING

Operator Extended Quarter Segment Units

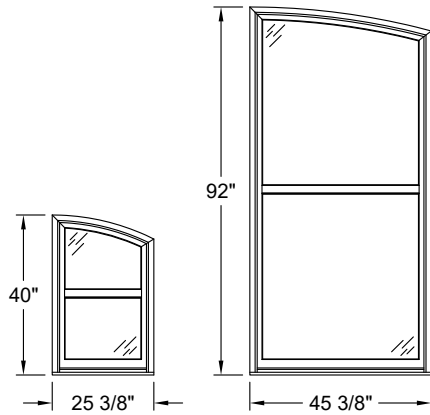

Minimum Size: 25 3/8" x 40"
Maximum Size: 45 3/8" x 92"

Standard Widths				
25 3/8"	29 3/8"	31 3/8"	33 3/8"	37 3/8"
41 3/8"	45 3/8"			

Standard Heights				
40"	44"	48"	52"	56"
60"	64"	68"	72"	76"
80"	88"	92"		

Fixed Extended Quarter Segment Units

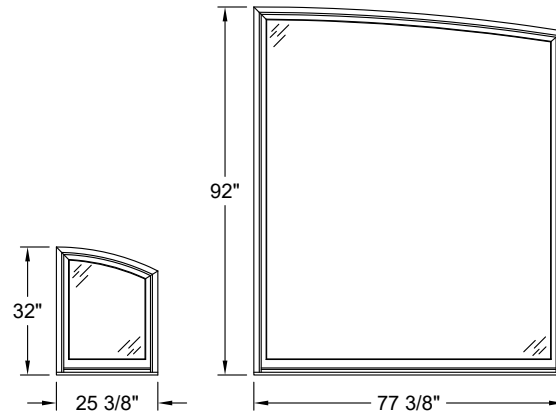

Minimum Size: 25 3/8" x 32"
Maximum Size: 77 3/8" x 92"

Standard Widths						
25 3/8"	29 3/8"	31 3/8"	33 3/8"	37 3/8"	41 3/8"	45 3/8"
49 3/8"	53 3/8"	61 3/8"	69 3/8"	77 3/8"		

Standard Heights						
32"	36"	40"	44"	48"	52"	56"
60"	64"	68"	72"	76"	80"	88"
92"						

Operator Extended Half Round Units

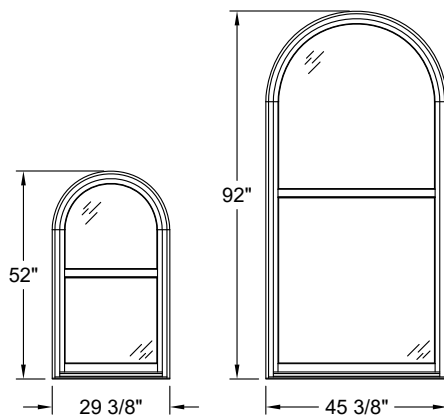

Minimum Size: 29 3/8" x 52"
Maximum Size: 45 3/8" x 92"

Standard Widths				
25 3/8"	29 3/8"	31 3/8"	33 3/8"	37 3/8"
41 3/8"	45 3/8"			

Standard Heights				
52"	56"	60"	64"	68"
72"	76"	80"	88"	92"

Fixed Extended Half Round Units

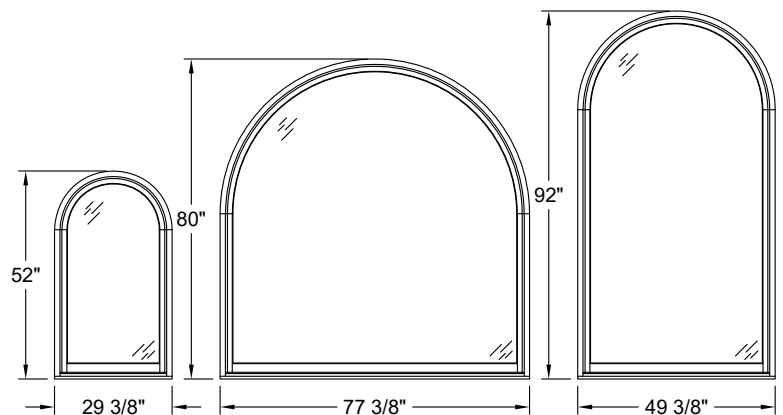

Minimum Size: 29 3/8" x 52"
Maximum Width: 77 3/8" x 80"
Maximum Height: 49 3/8" x 92"

Standard Widths						
29 3/8"	31 3/8"	33 3/8"	35 3/8"	37 3/8"	41 3/8"	45 3/8"
49 3/8"	53 3/8"	61 3/8"	69 3/8"	77 3/8"		

Standard Heights						
52"	56"	60"	64"	68"	72"	76"
80"	88"	92"				

FORMULAS

Understanding JELD-WEN Book Codes:

Siteline® Product	Prefix	Width Code	Height Code
Wood Double-Hung	SWD	WW	HH
Wood Double-Hung Fixed	SWDP		
Wood Double-Hung Transom	SWDT		
Wood Double-Hung Extended Circle Segment	SWDS		
Wood Double-Hung Fixed Extended Circle Segment	SWDSP		
Wood Double-Hung Extended Quarter Segment	SWDQTRS		
Wood Double-Hung Fixed Extended Quarter Segment	SWDQQP		
Wood Double-Hung Extended Half Round	SWDH		
Wood Double-Hung Fixed Extended Half Round	SWDHP		

Sample Book Code:

SWD3548 = Siteline® Wood Double-Hung, 35 3/8" x 48" Frame Size

Standard Unit Formulas	
Rough Opening	$(\text{Frame Width} + 3/4") \times (\text{Frame Height} + 3/4")$
Masonry Opening	$(\text{Overall Width} + 1/2") \times (\text{Overall Height} + 1/2")$
Daylight Opening ft ² (Standard)	$((\text{Frame Width} - 6 3/8") \times (\text{Frame Height} - 9 1/2")) / 144$
Daylight Opening ft ² (Fixed)	$((\text{Frame Width} - 6 9/16") \times (\text{Frame Height} - 7 3/16")) / 144$
Clear Opening ft ²	
Rectangle	$((\text{Frame Width} - 3 3/4") \times (\text{Frame Height} / 2 - 3 21/32")) / 144$
Circle / Quarter Segment	$((\text{Frame Width} - 3 3/4") \times (\text{Frame Height} / 2 - 11 17/32")) / 144$
Half Round	$((\text{Frame Width} - 3 3/4") \times ((\text{Frame Height} / 2) - (\text{Frame Width} / 2) - 3 21/32")) / 144$

"Overall" dimensions include frame and trim.

Unit elevations are shown without exterior trim and with an even vent division.

For Extended Quarter and Circle Segment Units, Leg Height = Frame Height - 6".

EGRESS CHARTS

Standard Rectangle Units

		Width (Inches)								
		21 3/8	25 3/8	29 3/8	31 3/8	33 3/8	35 3/8	37 3/8	41 3/8	45 3/8
Height (Inches)	32	1.51	1.85	2.20	2.37	2.54	2.71	2.88	3.23	3.57
	36	1.76	2.15	2.55	2.75	2.95	3.15	3.35	3.75	4.15
	40	2.00	2.45	2.91	3.14	3.36	3.59	3.82	4.27	4.72
	44	2.25	2.75	3.26	3.52	3.77	4.03	4.28	4.79	5.30
	48	2.49	3.06	3.62	3.90	4.19	4.47	4.75	5.32	5.88
	52	2.73	3.36	3.98	4.29	4.60	4.91	5.22	5.84	6.46
	56	2.98	3.66	4.33	4.67	5.01	5.35	5.68	6.36	7.04
	60	3.22	3.96	4.69	5.05	5.42	5.79	6.15	6.88	7.62
	64	3.47	4.26	5.04	5.44	5.83	6.22	6.62	7.41	8.19
	68	3.71	4.56	5.40	5.82	6.24	6.66	7.09	7.93	8.77
	72	3.96	4.86	5.76	6.20	6.65	7.10	7.55	8.45	9.35
	76	4.20	5.16	6.11	6.59	7.07	7.54	8.02	8.97	9.93
	80	4.45	5.46	6.47	6.97	7.48	7.98	8.49	9.50	10.51
	88	4.94	6.06	7.18	7.74	8.30	8.86	9.42	10.54	11.66
92	5.18	6.36	7.54	8.12	8.71	9.30	9.89	11.06	12.24	

Standard Extended Circle & Quarter Segment Units

		Width (Inches)						
		25 3/8	29 3/8	31 3/8	33 3/8	37 3/8	41 3/8	45 3/8
Height (Inches)	40	1.27	1.51	1.62	1.74	1.98	2.21	2.45
	44	1.57	1.86	2.01	2.15	2.44	2.74	3.03
	48	1.87	2.22	2.39	2.57	2.91	3.26	3.60
	52	2.17	2.57	2.78	2.98	3.38	3.78	4.18
	56	2.47	2.93	3.16	3.39	3.85	4.30	4.76
	60	2.77	3.29	3.54	3.80	4.31	4.83	5.34
	64	3.07	3.64	3.93	4.21	4.78	5.35	5.92
	68	3.37	4.00	4.31	4.62	5.25	5.87	6.49
	72	3.67	4.35	4.69	5.03	5.71	6.39	7.07
	76	3.97	4.71	5.08	5.45	6.18	6.92	7.65
	80	4.28	5.07	5.46	5.86	6.65	7.44	8.23
	88	4.88	5.78	6.23	6.68	7.58	8.48	9.39
	92	5.18	6.13	6.61	7.09	8.05	9.01	9.96

Standard Extended Half Round Units

		Width (Inches)						
		29 3/8	31 3/8	33 3/8	35 3/8	37 3/8	41 3/8	45 3/8
Height (Inches)	52	1.36	1.28	1.16	-	-	-	-
	56	1.72	1.66	1.58	1.46	1.32	-	-
	60	2.07	2.04	1.99	1.90	1.79	1.48	-
	64	2.43	2.43	2.40	2.34	2.25	2.00	1.64
	68	2.79	2.81	2.81	2.78	2.72	2.52	2.21
	72	3.14	3.20	3.22	3.22	3.19	3.05	2.79
	76	3.50	3.58	3.63	3.66	3.66	3.57	3.37
	80	3.85	3.96	4.04	4.10	4.12	4.09	3.95
	88	4.57	4.73	4.87	4.98	5.06	5.14	5.10
	92	4.92	5.11	5.28	5.42	5.52	5.66	5.68

- Unit meets egress specifications of equal to or greater than 20" width, 24" height, and 5.7ft².
- Unit meets egress specifications of equal to or greater than 20" width, 24" height, and 5.0ft².
- ##** Indicates the clear opening square footage.

Local codes may differ; always refer to the codes in your area for complete requirements.

COTTAGE VENT LAYOUTS

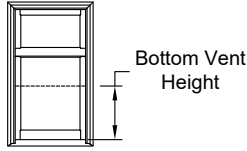

Cottage Double-Hung

Height (Inches)	Available Bottom Vent Height (Inches)												
	19 1/32	21 1/32	23 1/32	25 1/32	27 1/32	29 1/32	31 1/32	33 1/32	35 1/32	37 1/32	39 1/32	43 1/32	45 1/32
32													
36	█												
40	█	█											
44		█	█										
48			█	█	█								
52				█	█	█	█						
56					█	█	█	█	█				
60						█	█	█	█	█			
64							█	█	█	█	█		
68								█	█	█	█	█	
72									█	█	█	█	
76										█	█	█	
80												█	█
88													
92													

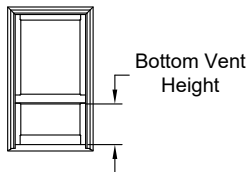

Reverse Cottage Double-Hung

Height (Inches)	Available Bottom Vent Height (Inches)										
	15 1/32	17 1/32	19 1/32	21 1/32	23 1/32	25 1/32	27 1/32	29 1/32	31 1/32	33 1/32	35 1/32
32											
36	█										
40	█	█									
44	█	█	█								
48	█	█	█	█							
52	█	█	█	█	█						
56	█	█	█	█	█	█					
60	█	█	█	█	█	█	█				
64		█	█	█	█	█	█	█			
68				█	█	█	█	█	█		
72						█	█	█	█	█	
76								█	█	█	█
80										█	█
88											
92											

Elevations shown for reference only.

STANDARD UNITS - RECTANGLE

	22 1/8"	26 1/8"	30 1/8"	32 1/8"	34 1/8"	36 1/8"	38 1/8"	Rough Opening
	21 3/8"	25 3/8"	29 3/8"	31 3/8"	33 3/8"	35 3/8"	37 3/8"	Frame Width
	15"	19"	23"	25"	27"	29"	31"	Daylight Opening
32 3/4"								
32"								
22 1/2"								
36 3/4"								
36"								
26 1/2"								
40 3/4"								
40"								
30 1/2"								
44 3/4"								
44"								
34 1/2"								
48 3/4"								
48"								
38 1/2"								
52 3/4"								
52"								
42 1/2"								

Rough Opening
Frame Height
Daylight Opening

Elevation Legend:
= Maximum Performance Grade (PG) Rating With Standard Glazing

STANDARD UNITS - RECTANGLE

	22 1/8"	26 1/8"	30 1/8"	32 1/8"	34 1/8"	36 1/8"	38 1/8"	Rough Opening
	21 3/8"	25 3/8"	29 3/8"	31 3/8"	33 3/8"	35 3/8"	37 3/8"	Frame Width
	15"	19"	23"	25"	27"	29"	31"	Daylight Opening
56 3/4"								
56"								
46 1/2"								
60 3/4"								
60"								
50 1/2"								
64 3/4"								
64"								
54 1/2"								
68 3/4"								
68"								
58 1/2"								

Elevation Legend:
 ## = Maximum Performance Grade (PG) Rating With Standard Glazing
 E* = Unit Meets Egress - Clear Opening Exceeds 20" Width, 24" Height And 5.0ft²
 E = Unit Meets Egress - Clear Opening Exceeds 20" Width, 24" Height And 5.7ft²

STANDARD UNITS - RECTANGLE

	22 1/8"	26 1/8"	30 1/8"	32 1/8"	34 1/8"	36 1/8"	38 1/8"	Rough Opening
	21 3/8"	25 3/8"	29 3/8"	31 3/8"	33 3/8"	35 3/8"	37 3/8"	Frame Width
	15"	19"	23"	25"	27"	29"	31"	Daylight Opening
72 3/4" 72" 62 1/2"								
	SWD2172	SWD2572	SWD2972	SWD3172	SWD3372	SWD3572	SWD3772	
76 3/4" 76" 66 1/2"								
	SWD2176	SWD2576	SWD2976	SWD3176	SWD3376	SWD3576	SWD3776	
80 3/4" 80" 70 1/2"								
	SWD2180	SWD2580	SWD2980	SWD3180	SWD3380	SWD3580	SWD3780	

Elevation Legend:
 ## = Maximum Performance Grade (PG) Rating With Standard Glazing
 E* = Unit Meets Egress - Clear Opening Exceeds 20" Width, 24" Height And 5.0ft²
 E = Unit Meets Egress - Clear Opening Exceeds 20" Width, 24" Height And 5.7ft²

STANDARD UNITS - RECTANGLE

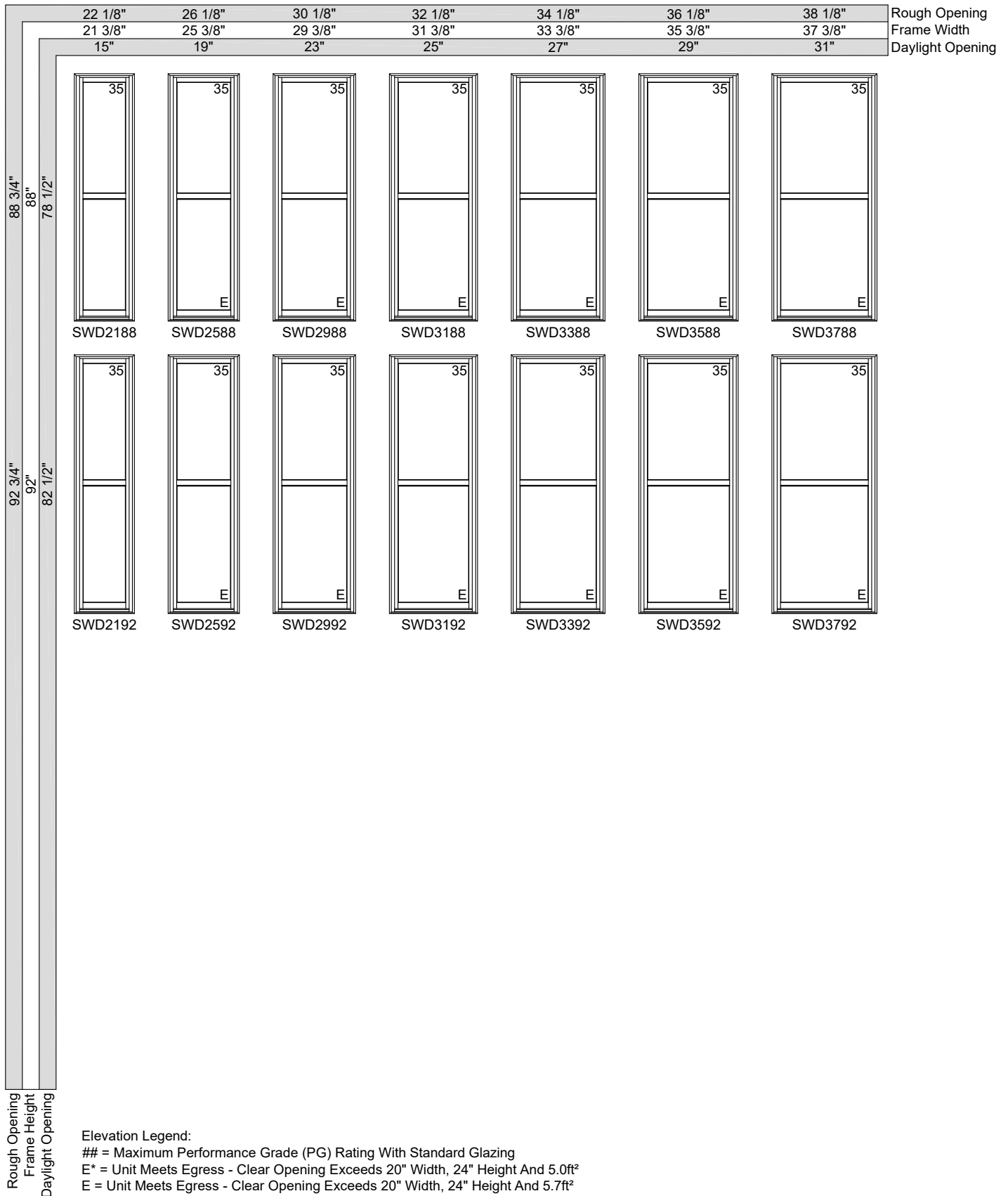

STANDARD UNITS - RECTANGLE

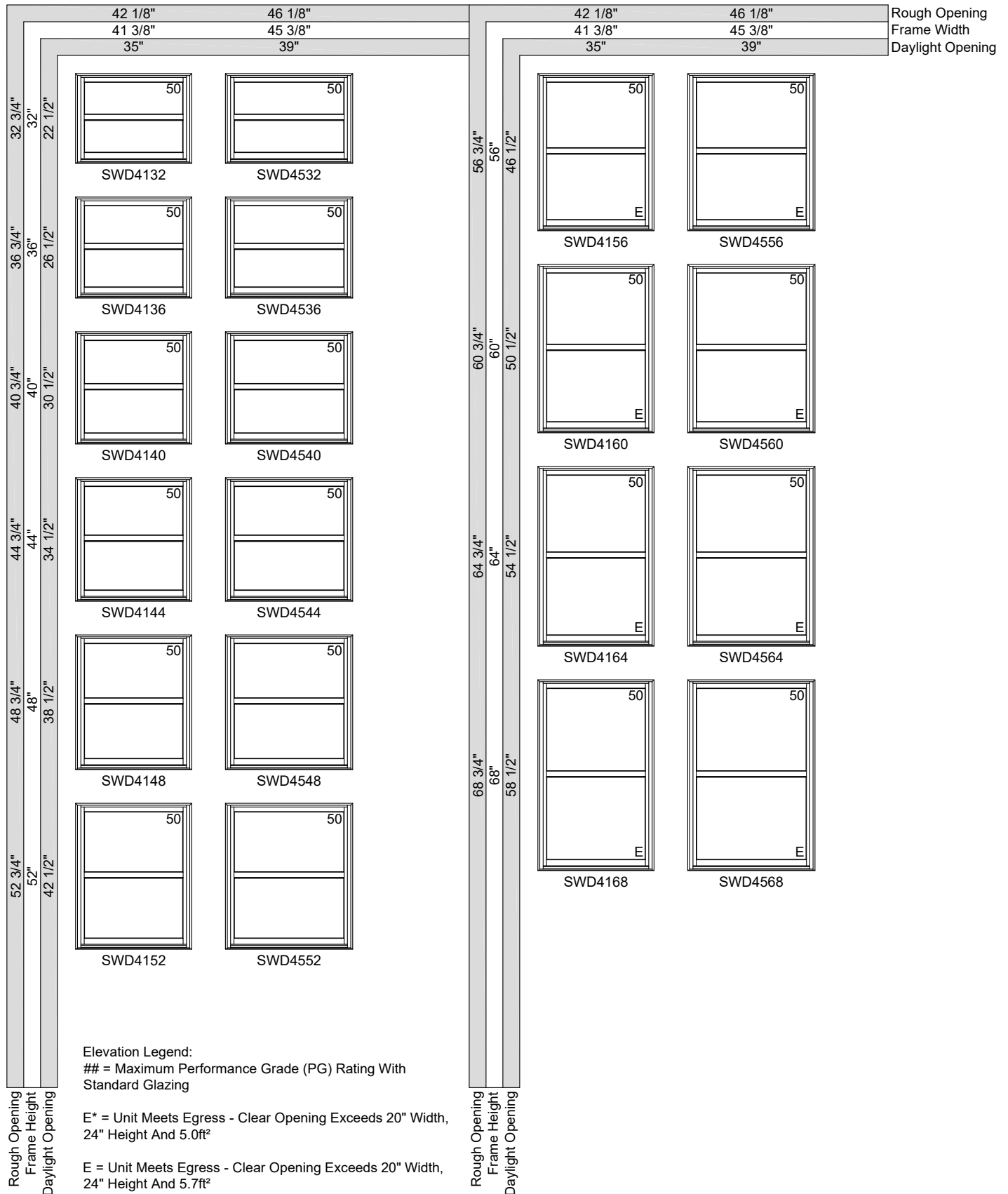

STANDARD UNITS - RECTANGLE

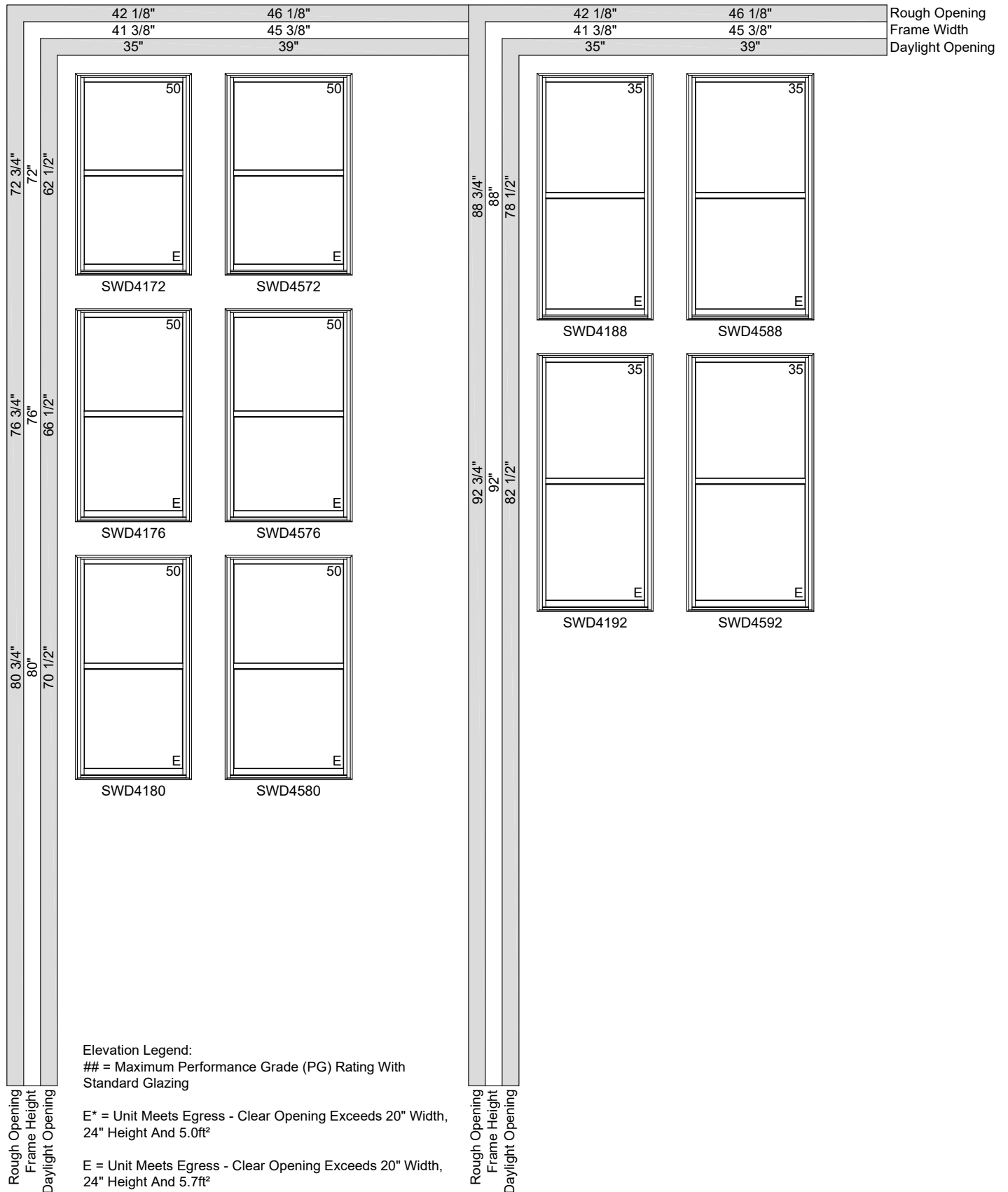

STANDARD UNITS - EXTENDED CIRCLE SEGMENT

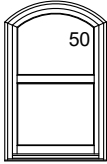
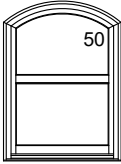
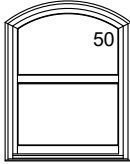
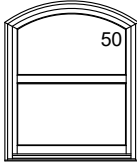
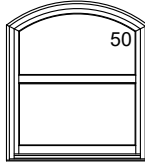
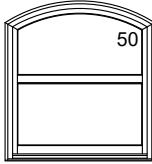
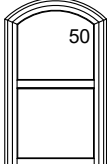
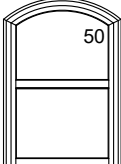
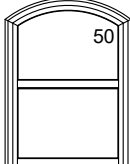
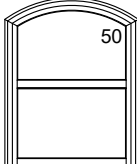
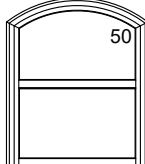
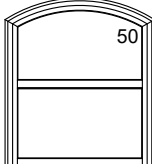
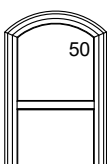
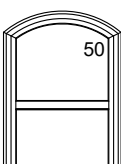
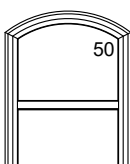
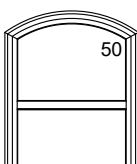
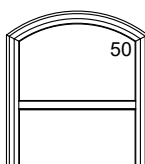
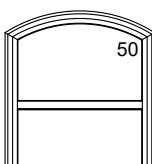
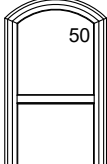
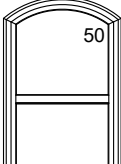
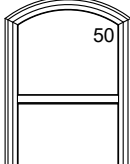
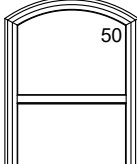
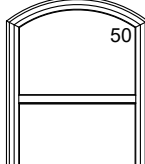
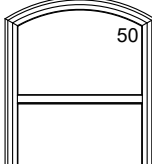
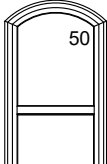
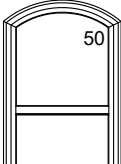
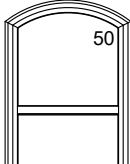
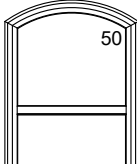
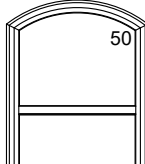
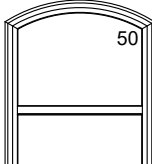
	26 1/8"	30 1/8"	32 1/8"	34 1/8"	36 1/8"	38 1/8"	Rough Opening
	25 3/8"	29 3/8"	31 3/8"	33 3/8"	35 3/8"	37 3/8"	Frame Width
	19"	23"	25"	27"	29"	31"	Daylight Opening
40 3/4" 40" 15 1/4" [2]							
44 3/4" 44" 17 1/4" [2]							
48 3/4" 48" 19 1/4" [2]							
52 3/4" 52" 21 1/4" [2]							
56 3/4" 56" 23 1/4" [2]							

Rough Opening
Frame Height
Daylight Opening

Elevation Legend:
= Maximum Performance Grade (PG) Rating With Standard Glazing
Leg Height = Frame Height - 6"

STANDARD UNITS - EXTENDED CIRCLE SEGMENT

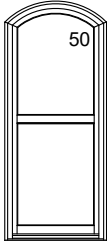
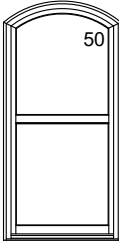
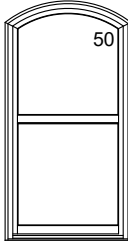
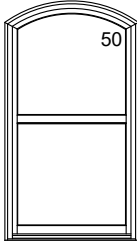
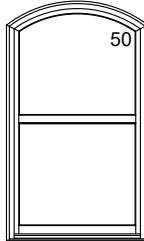
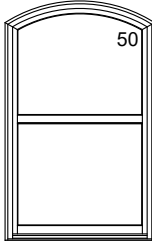
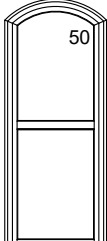
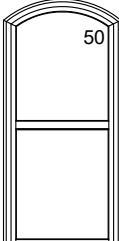
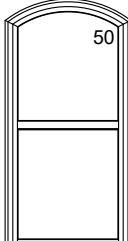
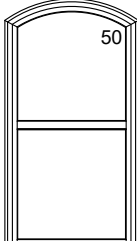
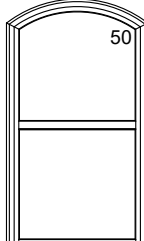
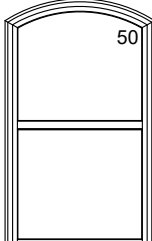
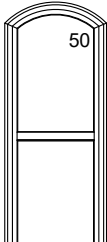
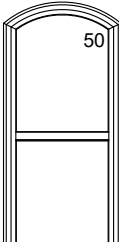
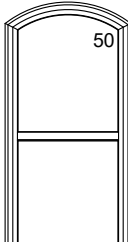
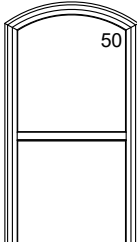
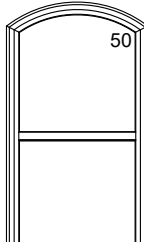
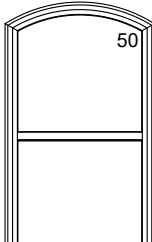
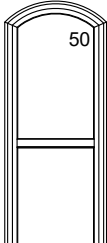
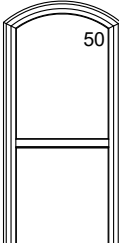
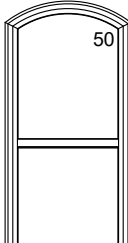
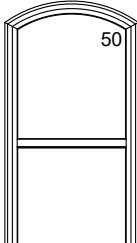
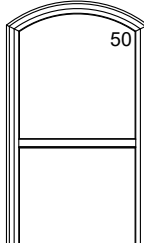
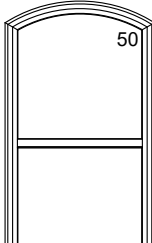
	26 1/8"	30 1/8"	32 1/8"	34 1/8"	36 1/8"	38 1/8"	Rough Opening
	25 3/8"	29 3/8"	31 3/8"	33 3/8"	35 3/8"	37 3/8"	Frame Width
	19"	23"	25"	27"	29"	31"	Daylight Opening
60 3/4" 60" 25 1/4" [2]							
	SWDS2560	SWDS2960	SWDS3160	SWDS3360	SWDS3560	SWDS3760	
64 3/4" 64" 27 1/4" [2]							
	SWDS2564	SWDS2964	SWDS3164	SWDS3364	SWDS3564	SWDS3764	
68 3/4" 68" 29 1/4" [2]							
	SWDS2568	SWDS2968	SWDS3168	SWDS3368	SWDS3568	SWDS3768	
72 3/4" 72" 31 1/4" [2]							
	SWDS2572	SWDS2972	SWDS3172	SWDS3372	SWDS3572	SWDS3772	

Rough Opening
Frame Height
Daylight Opening

Elevation Legend:
= Maximum Performance Grade (PG) Rating With Standard Glazing
E* = Unit Meets Egress - Clear Opening Exceeds 20" Width, 24" Height And 5.0ft²
E = Unit Meets Egress - Clear Opening Exceeds 20" Width, 24" Height And 5.7ft²
Leg Height = Frame Height - 6"

STANDARD UNITS - EXTENDED CIRCLE SEGMENT

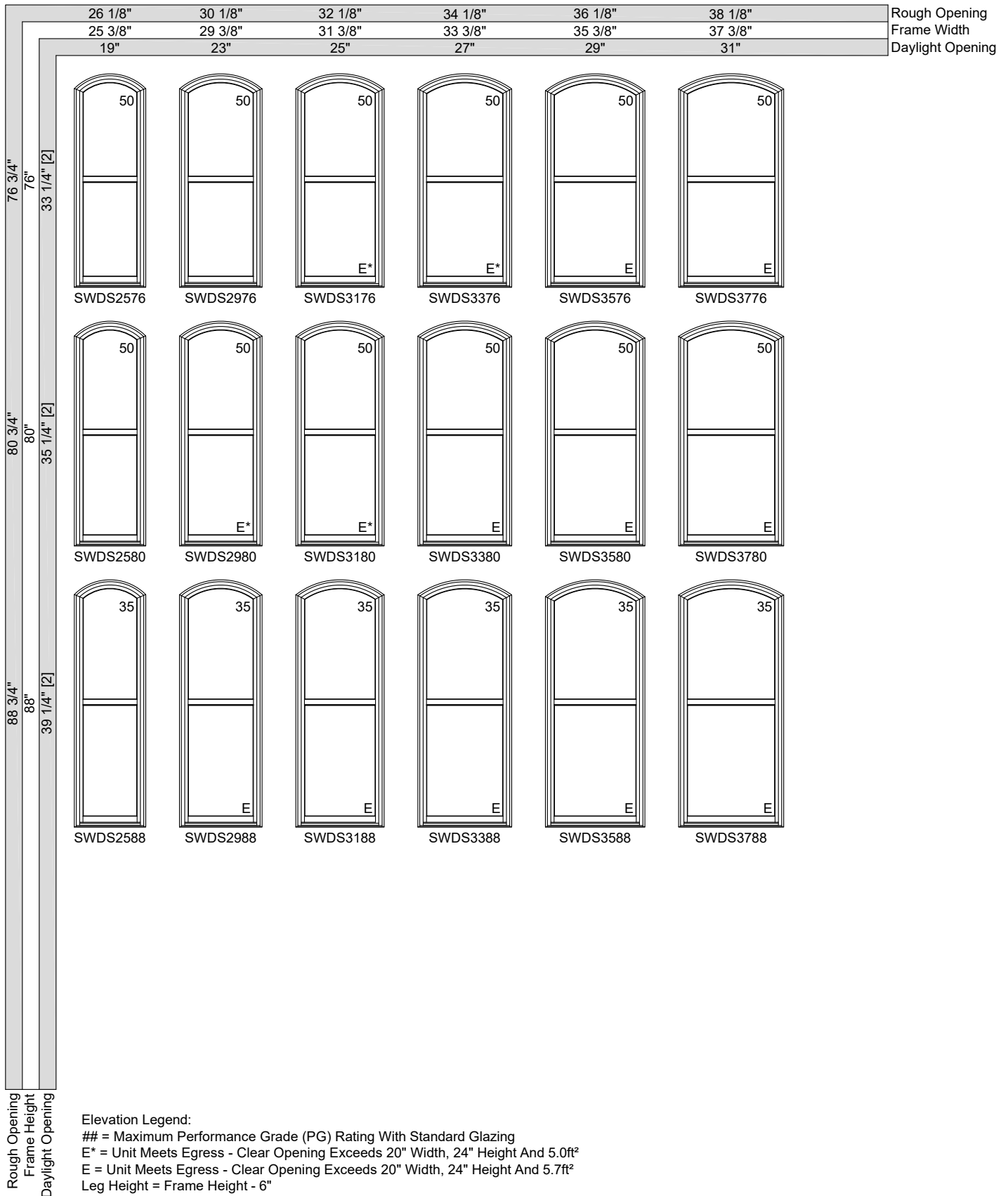

STANDARD UNITS - EXTENDED CIRCLE SEGMENT

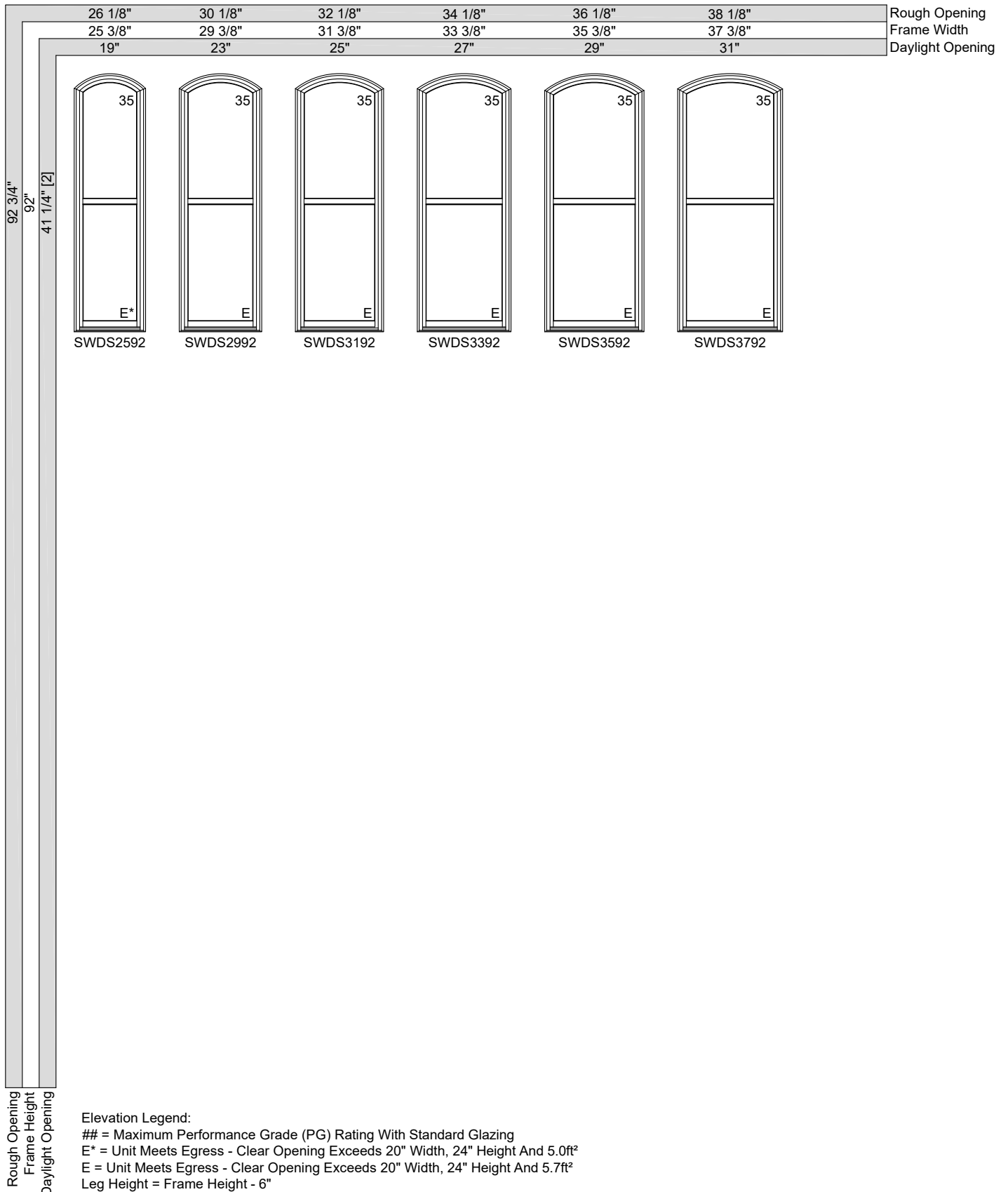



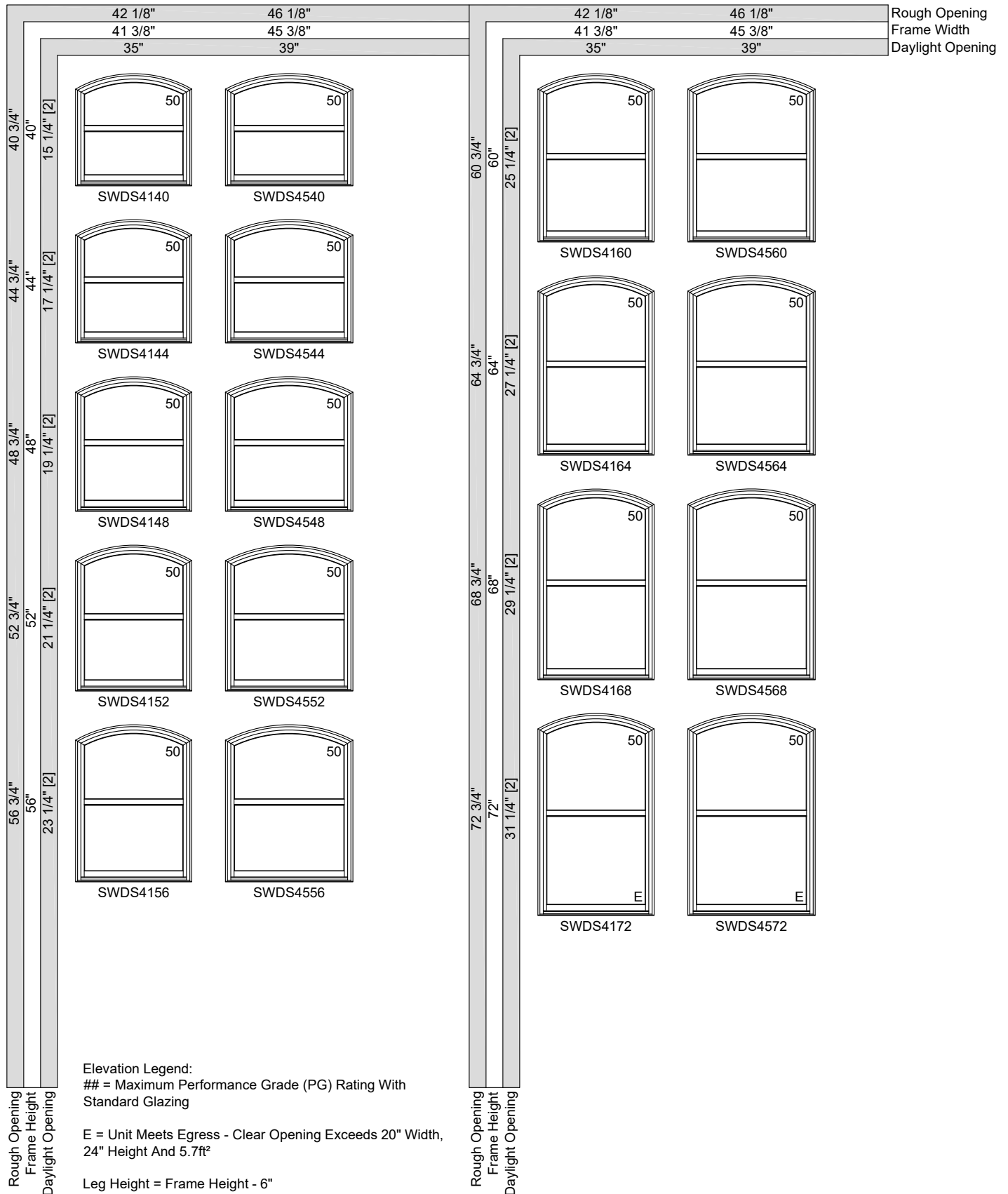



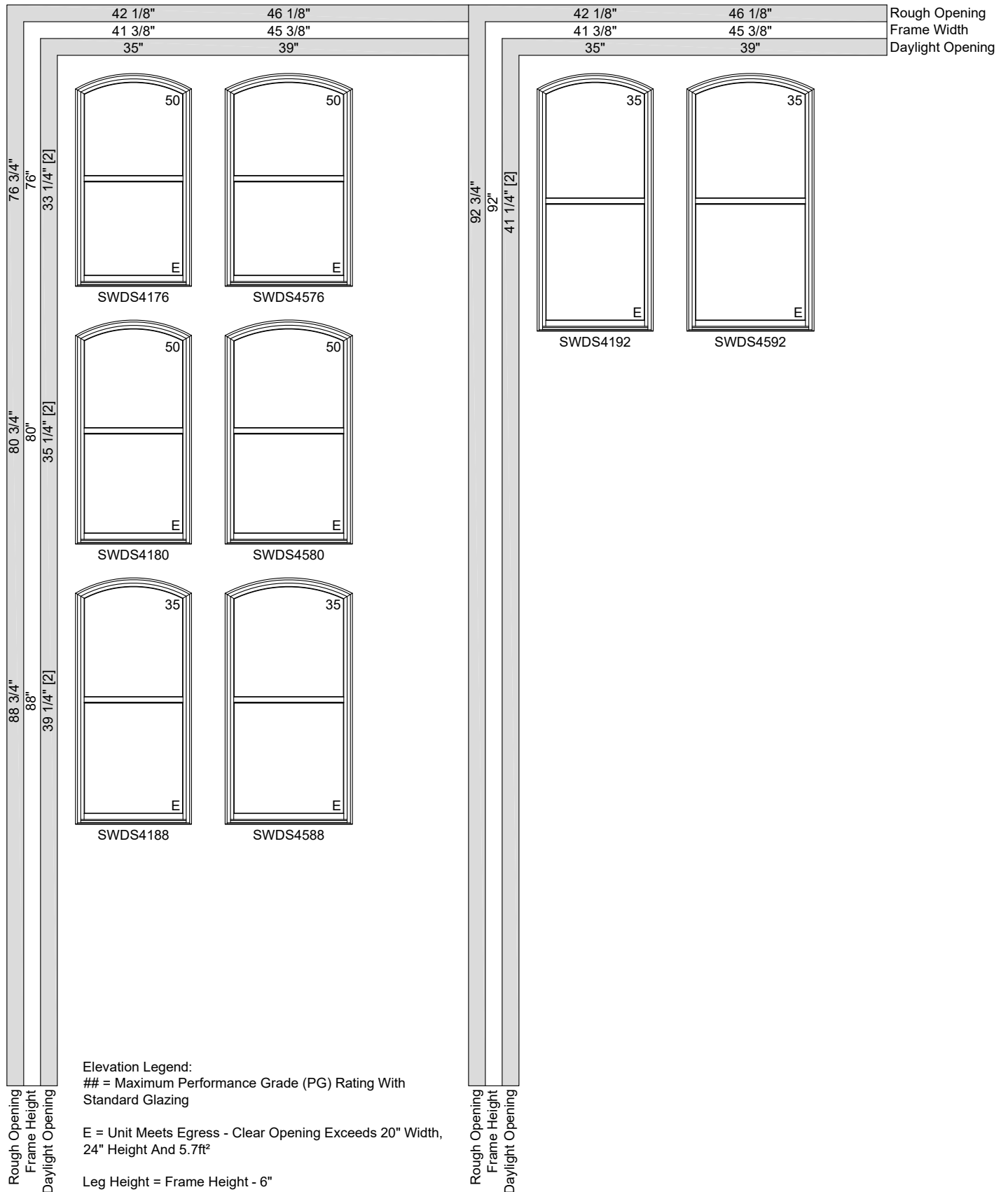



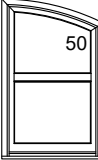

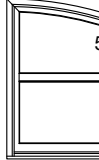
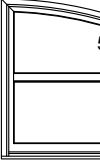

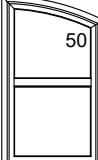
STANDARD UNITS - EXTENDED CIRCLE SEGMENT

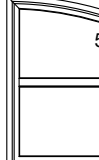
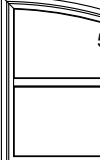

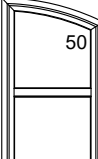
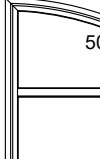
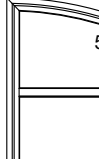
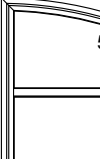
STANDARD UNITS - EXTENDED CIRCLE SEGMENT

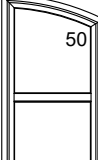
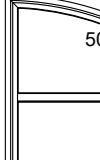
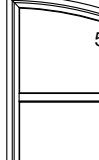
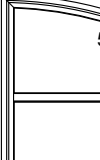

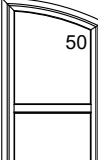
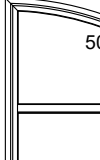
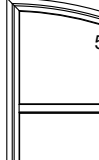
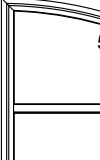
STANDARD UNITS - EXTENDED QUARTER SEGMENT

	26 1/8"	30 1/8"	32 1/8"	34 1/8"	38 1/8"	42 1/8"	Rough Opening
	25 3/8"	29 3/8"	31 3/8"	33 3/8"	37 3/8"	41 3/8"	Frame Width
	18 13/16"	22 13/16"	24 13/16"	26 13/16"	30 13/16"	34 13/16"	Daylight Opening
40 3/4" 40" 15 1/4" [2]	 50	 50	 50	 50	 50	 50	
	SWDQTRS2540	SWDQTRS2940	SWDQTRS3140	SWDQTRS3340	SWDQTRS3740	SWDQTRS4140	
44 3/4" 44" 17 1/4" [2]	 50	 50	 50	 50	 50	 50	
	SWDQTRS2544	SWDQTRS2944	SWDQTRS3144	SWDQTRS3344	SWDQTRS3744	SWDQTRS4144	
48 3/4" 48" 19 1/4" [2]	 50	 50	 50	 50	 50	 50	
	SWDQTRS2548	SWDQTRS2948	SWDQTRS3148	SWDQTRS3348	SWDQTRS3748	SWDQTRS4148	
52 3/4" 52" 21 1/4" [2]	 50	 50	 50	 50	 50	 50	
	SWDQTRS2552	SWDQTRS2952	SWDQTRS3152	SWDQTRS3352	SWDQTRS3752	SWDQTRS4152	
56 3/4" 56" 23 1/4" [2]	 50	 50	 50	 50	 50	 50	
	SWDQTRS2556	SWDQTRS2956	SWDQTRS3156	SWDQTRS3356	SWDQTRS3756	SWDQTRS4156	

Elevation Legend:
= Maximum Performance Grade (PG) Rating With Standard Glazing
Leg Height = Frame Height - 6"

STANDARD UNITS - EXTENDED QUARTER SEGMENT

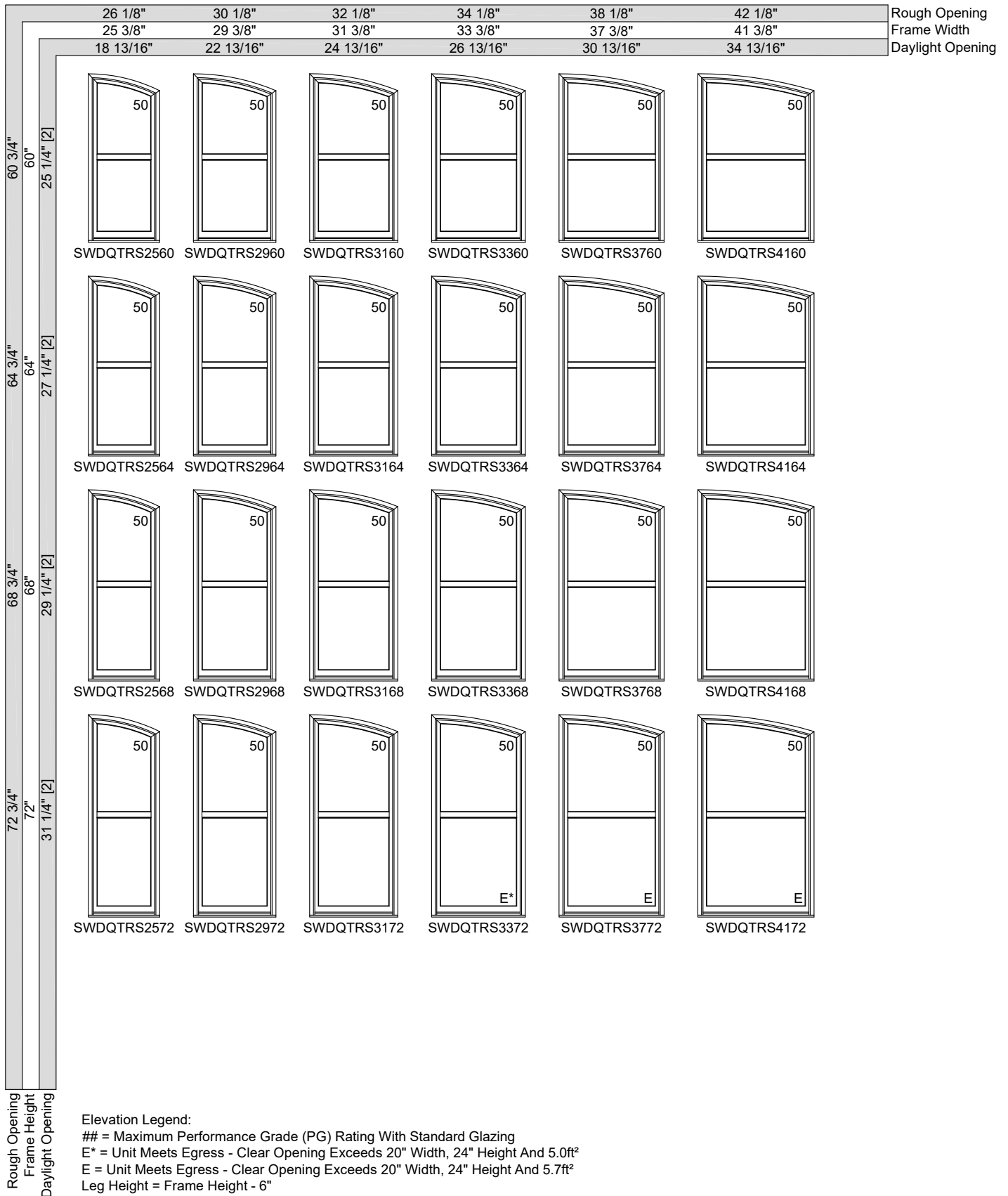

STANDARD UNITS - EXTENDED QUARTER SEGMENT

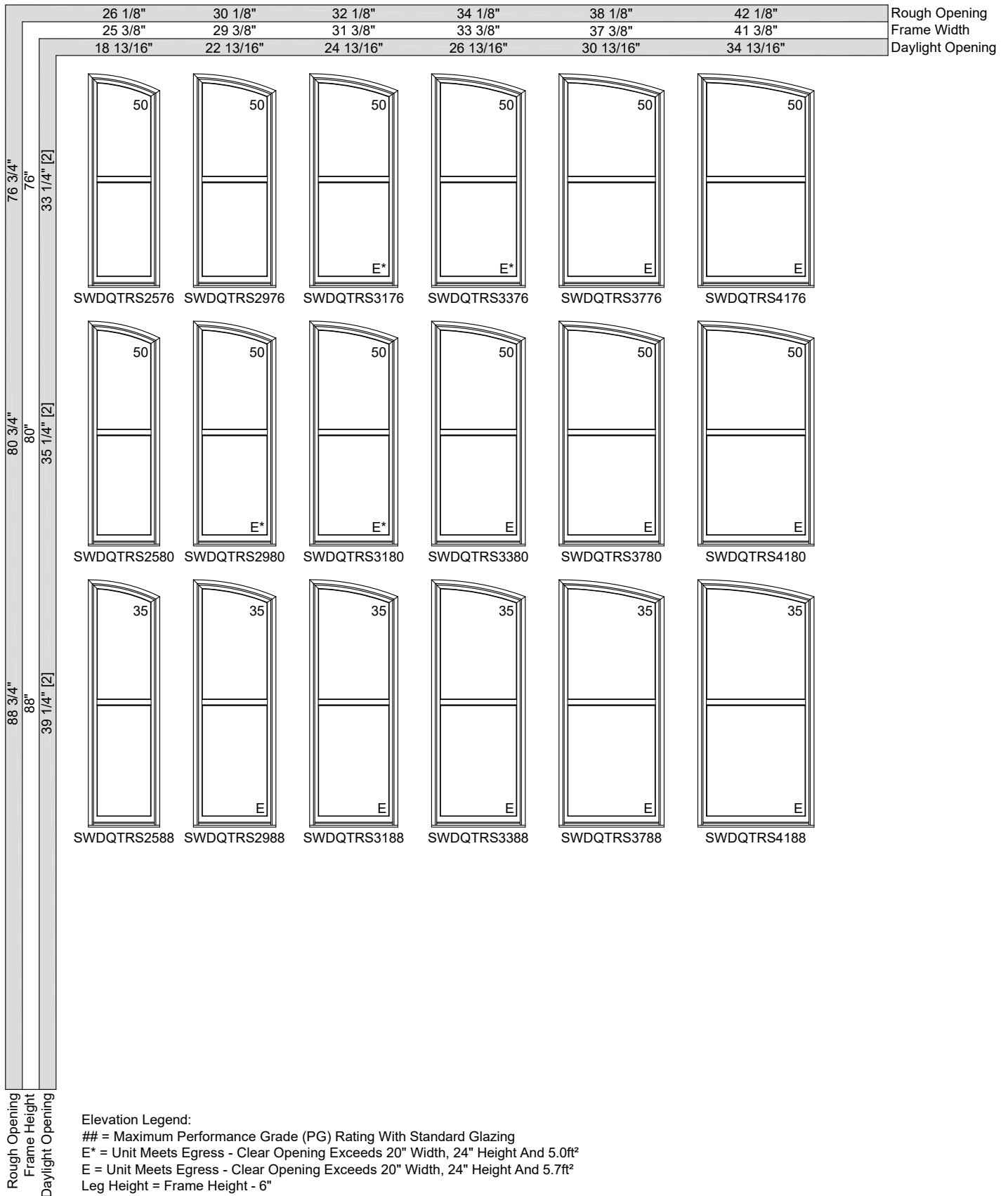

STANDARD UNITS - EXTENDED QUARTER SEGMENT

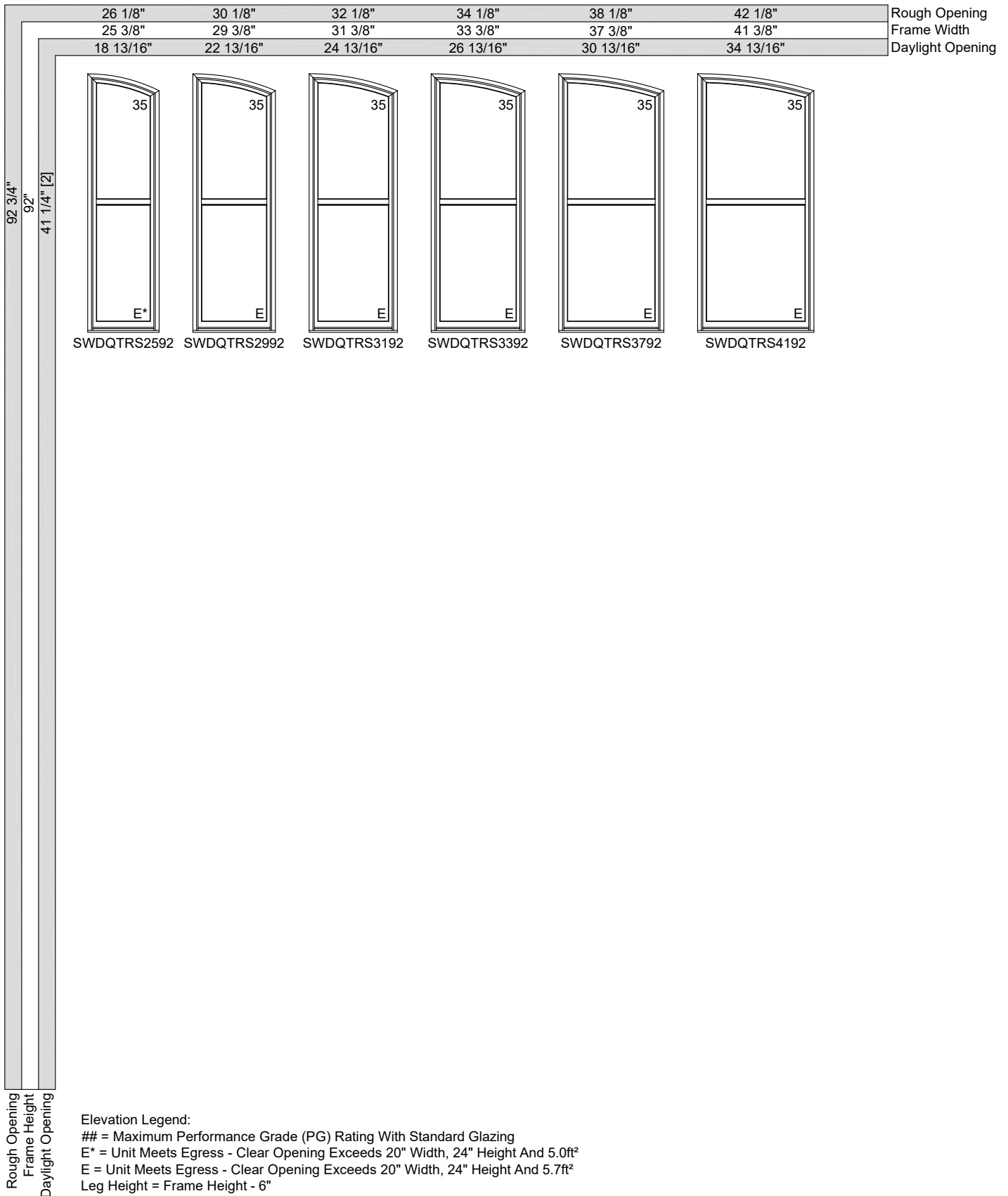

STANDARD UNITS - EXTENDED QUARTER SEGMENT

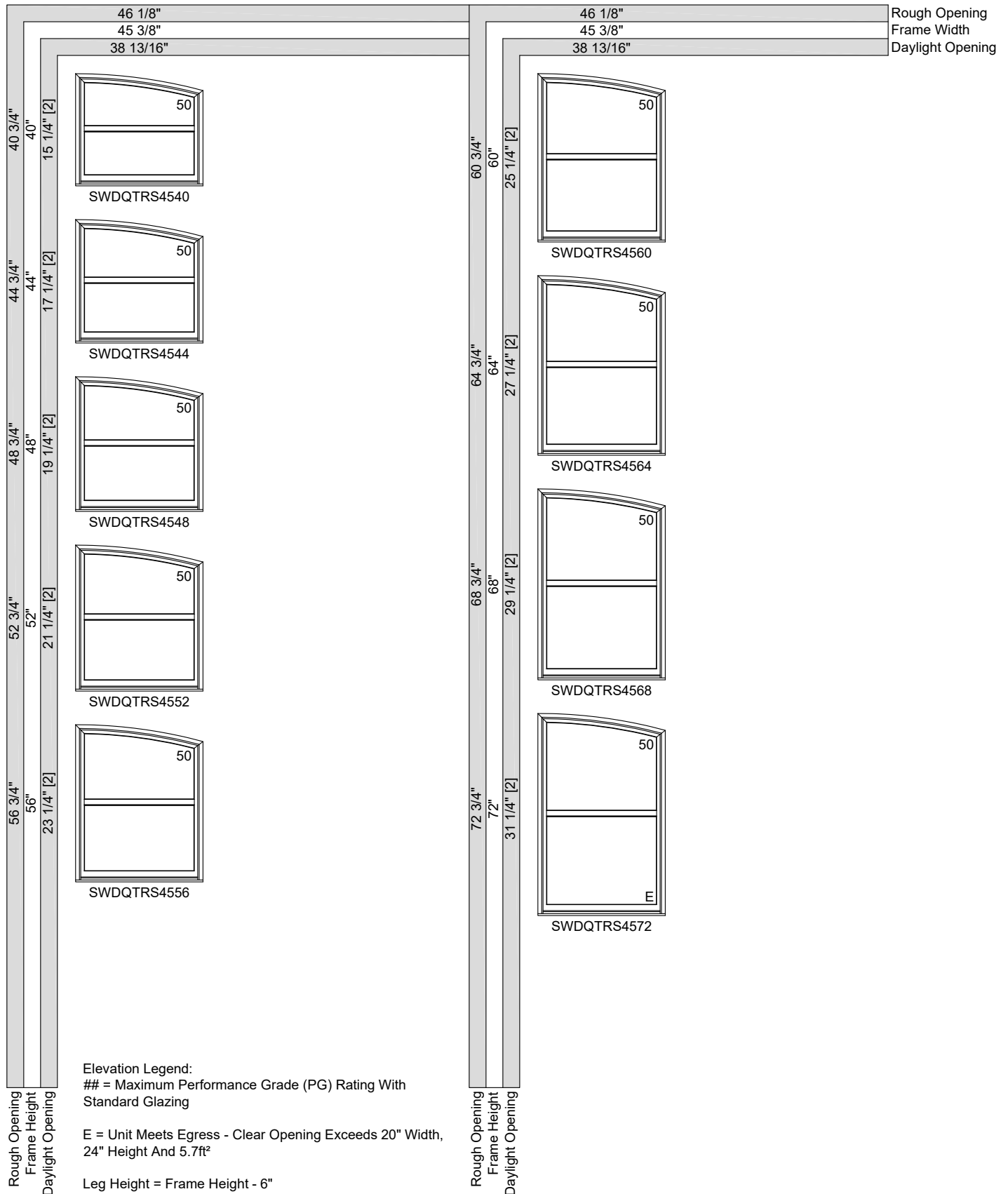

STANDARD UNITS - EXTENDED QUARTER SEGMENT

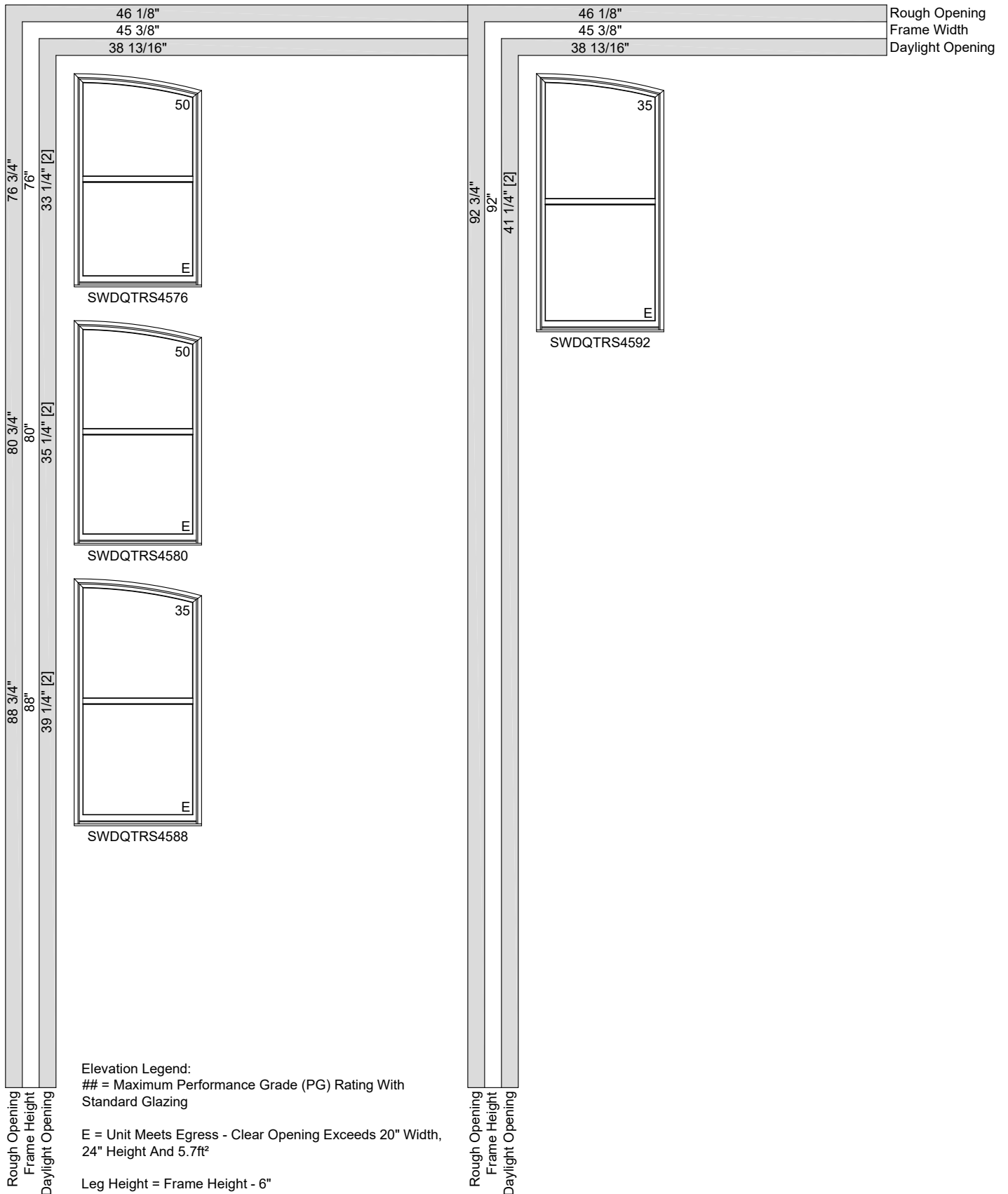

STANDARD UNITS - EXTENDED HALF ROUND

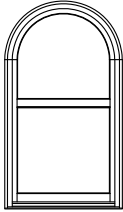
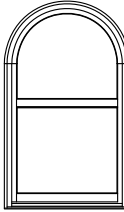
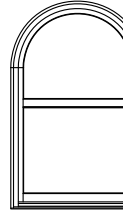
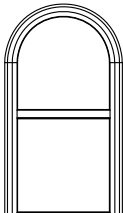
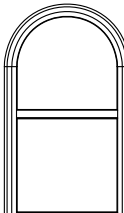
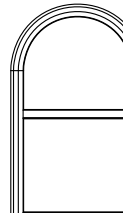
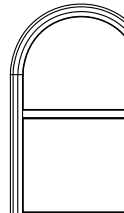
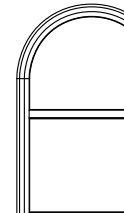
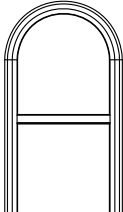
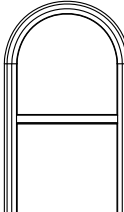
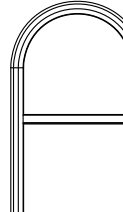
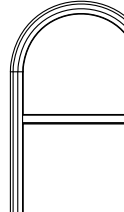
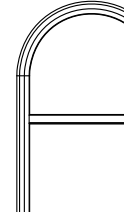
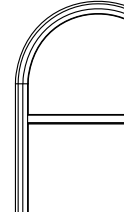
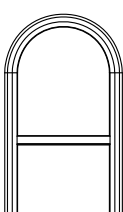
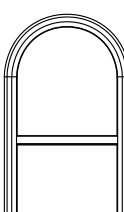
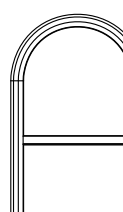
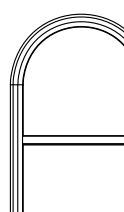
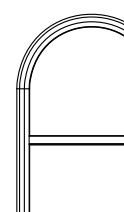
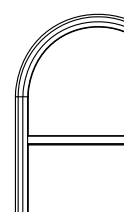
	30 1/8"	32 1/8"	34 1/8"	36 1/8"	38 1/8"	42 1/8"	Rough Opening
	29 3/8"	31 3/8"	33 3/8"	35 3/8"	37 3/8"	41 3/8"	Frame Width
	23"	25"	27"	29"	31"	35"	Daylight Opening
52 3/4" 52" 21 1/4" [2]	 SWDH2952	 SWDH3152	 SWDH3352	Not Available			
56 3/4" 56" 23 1/4" [2]	 SWDH2956	 SWDH3156	 SWDH3356	 SWDH3556	 SWDH3756	Not Available	
60 3/4" 60" 25 1/4" [2]	 SWDH2960	 SWDH3160	 SWDH3360	 SWDH3560	 SWDH3760	 SWDH4160	
64 3/4" 64" 27 1/4" [2]	 SWDH2964	 SWDH3164	 SWDH3364	 SWDH3564	 SWDH3764	 SWDH4164	

STANDARD UNITS - EXTENDED HALF ROUND

	30 1/8"	32 1/8"	34 1/8"	36 1/8"	38 1/8"	42 1/8"	Rough Opening
	29 3/8"	31 3/8"	33 3/8"	35 3/8"	37 3/8"	41 3/8"	Frame Width
	23"	25"	27"	29"	31"	35"	Daylight Opening
68 3/4"							
68"							
29 1/4" [2]							
72 3/4"							
72"							
31 1/4" [2]							
76 3/4"							
76"							
33 1/4" [2]							
80 3/4"							
80"							
35 1/4" [2]							

STANDARD UNITS - EXTENDED HALF ROUND

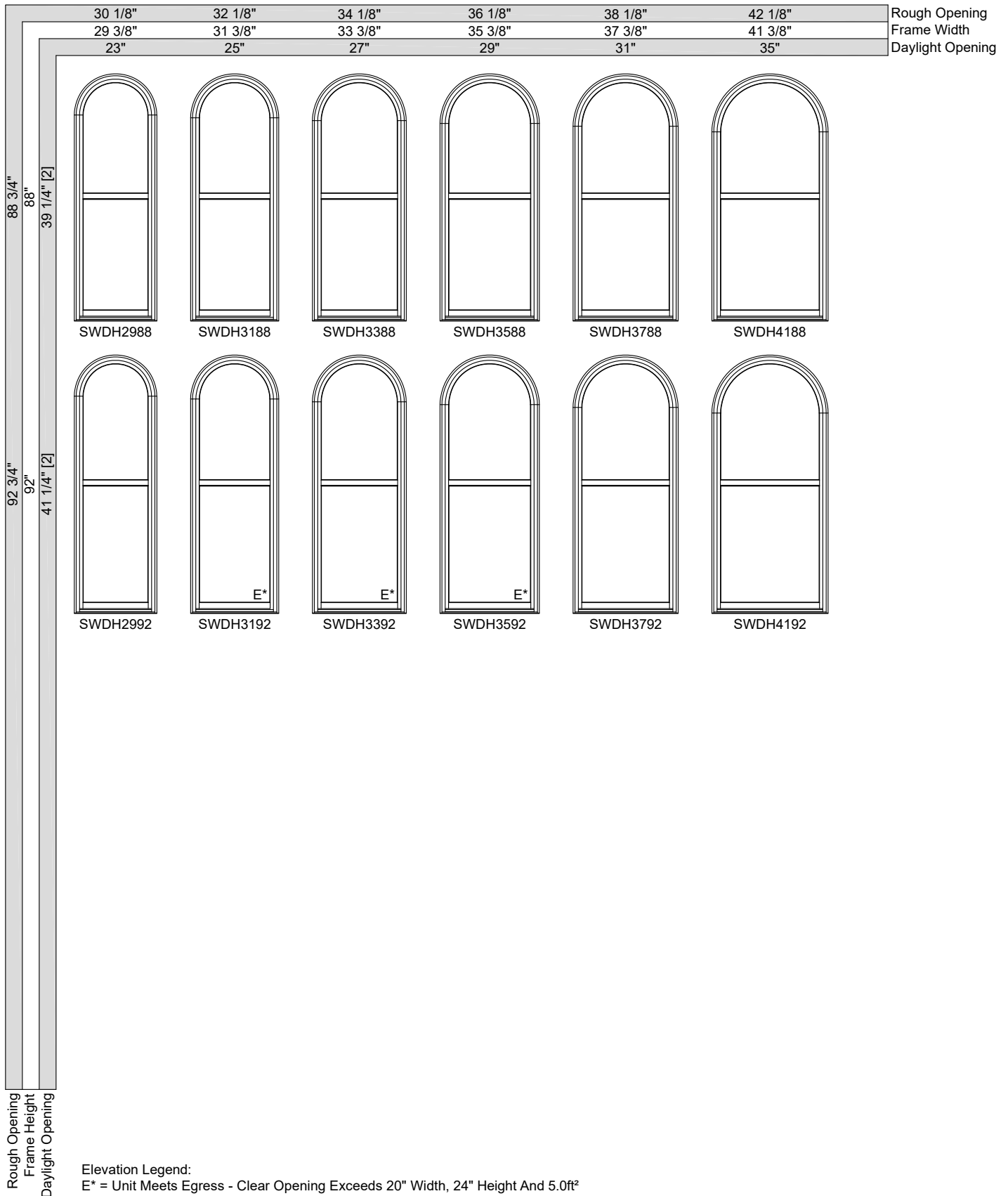

STANDARD UNITS - EXTENDED HALF ROUND

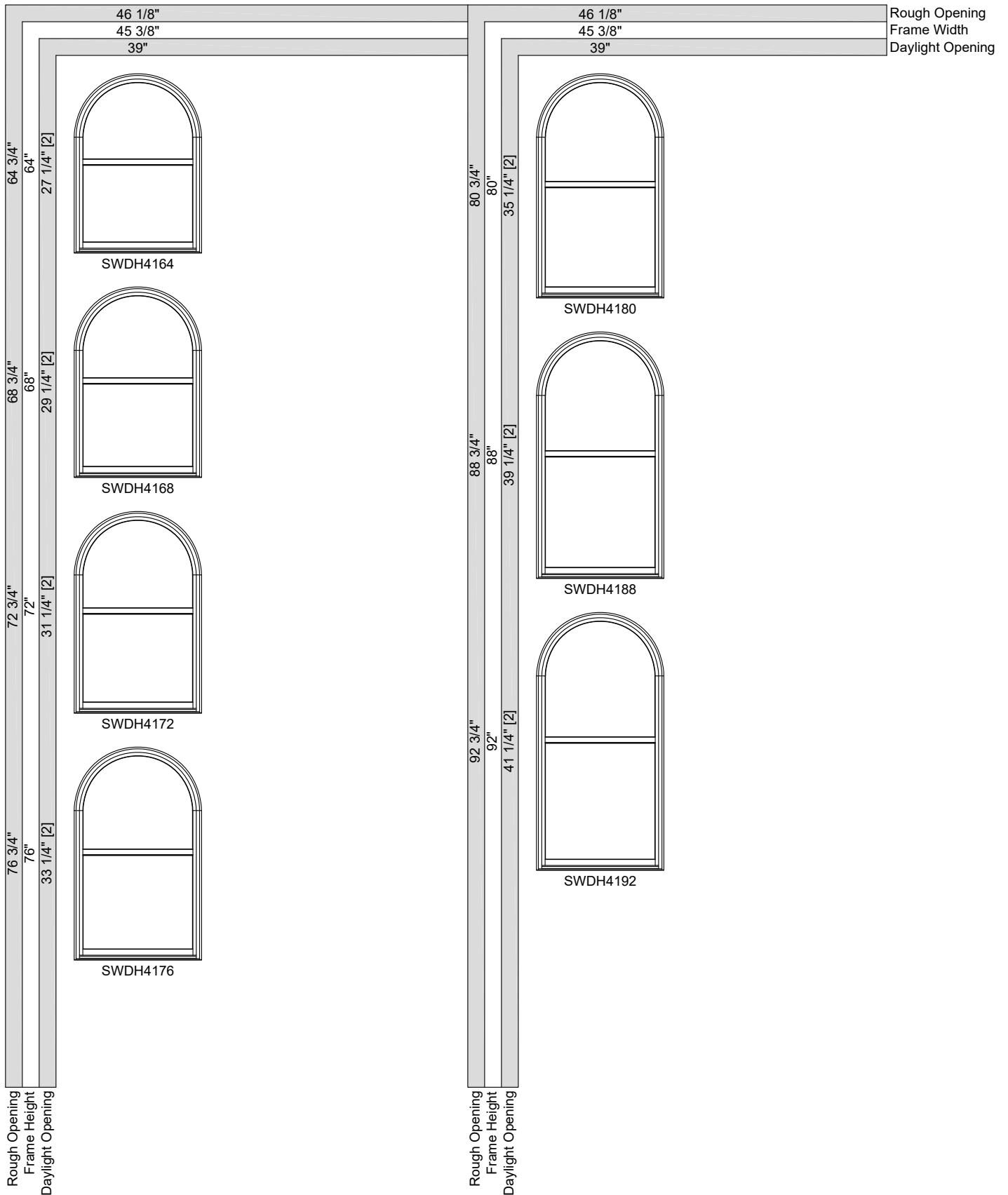

FIXED UNITS - RECTANGLE

	22 1/8"	26 1/8"	30 1/8"	32 1/8"	34 1/8"	36 1/8"	38 1/8"	Rough Opening
	21 3/8"	25 3/8"	29 3/8"	31 3/8"	33 3/8"	35 3/8"	37 3/8"	Frame Width
	14 13/16"	18 13/16"	22 13/16"	24 13/16"	26 13/16"	28 13/16"	30 13/16"	Daylight Opening
15 3/4"								
15"								
18 3/4"								
18"								
24 3/4"								
24"								
32 3/4"								
32"								
36 3/4"								
36"								
40 3/4"								
40"								
44 3/4"								
44"								

Elevation Legend:
 ## = Maximum Performance Grade (PG) Rating With Standard Glazing
 T = Transom Unit Available - See Min-Max Sizing & Formulas Page for Bookcode Format

FIXED UNITS - RECTANGLE

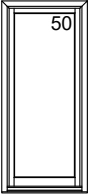
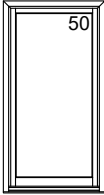
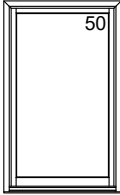
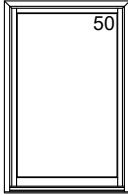
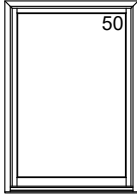
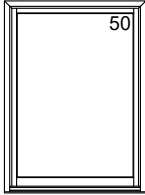
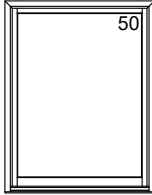
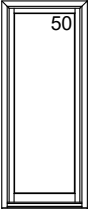
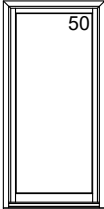
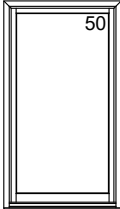
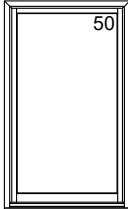
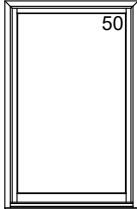
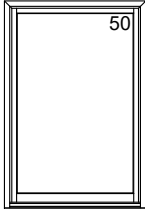
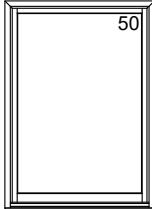
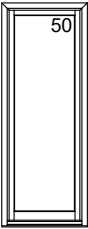
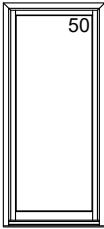
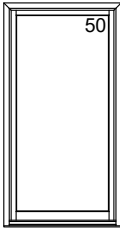
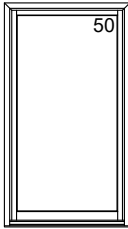
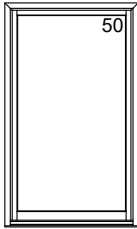
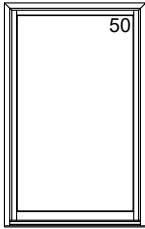
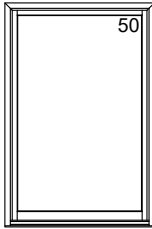
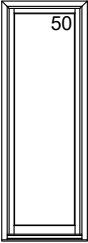
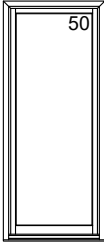
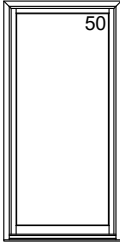
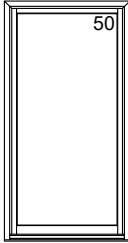
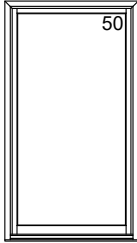
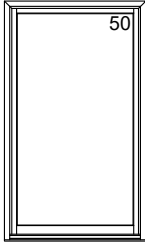
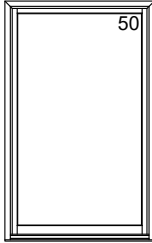
	22 1/8"	26 1/8"	30 1/8"	32 1/8"	34 1/8"	36 1/8"	38 1/8"	Rough Opening
	21 3/8"	25 3/8"	29 3/8"	31 3/8"	33 3/8"	35 3/8"	37 3/8"	Frame Width
	14 13/16"	18 13/16"	22 13/16"	24 13/16"	26 13/16"	28 13/16"	30 13/16"	Daylight Opening
48 3/4" 48" 40 13/16"								
	SWDP2148	SWDP2548	SWDP2948	SWDP3148	SWDP3348	SWDP3548	SWDP3748	
52 3/4" 52" 44 13/16"								
	SWDP2152	SWDP2552	SWDP2952	SWDP3152	SWDP3352	SWDP3552	SWDP3752	
56 3/4" 56" 48 13/16"								
	SWDP2156	SWDP2556	SWDP2956	SWDP3156	SWDP3356	SWDP3556	SWDP3756	
60 3/4" 60" 52 13/16"								
	SWDP2160	SWDP2560	SWDP2960	SWDP3160	SWDP3360	SWDP3560	SWDP3760	

Elevation Legend:

= Maximum Performance Grade (PG) Rating With Standard Glazing

T = Transom Unit Available - See Min-Max Sizing & Formulas Page for Bookcode Format

FIXED UNITS - RECTANGLE

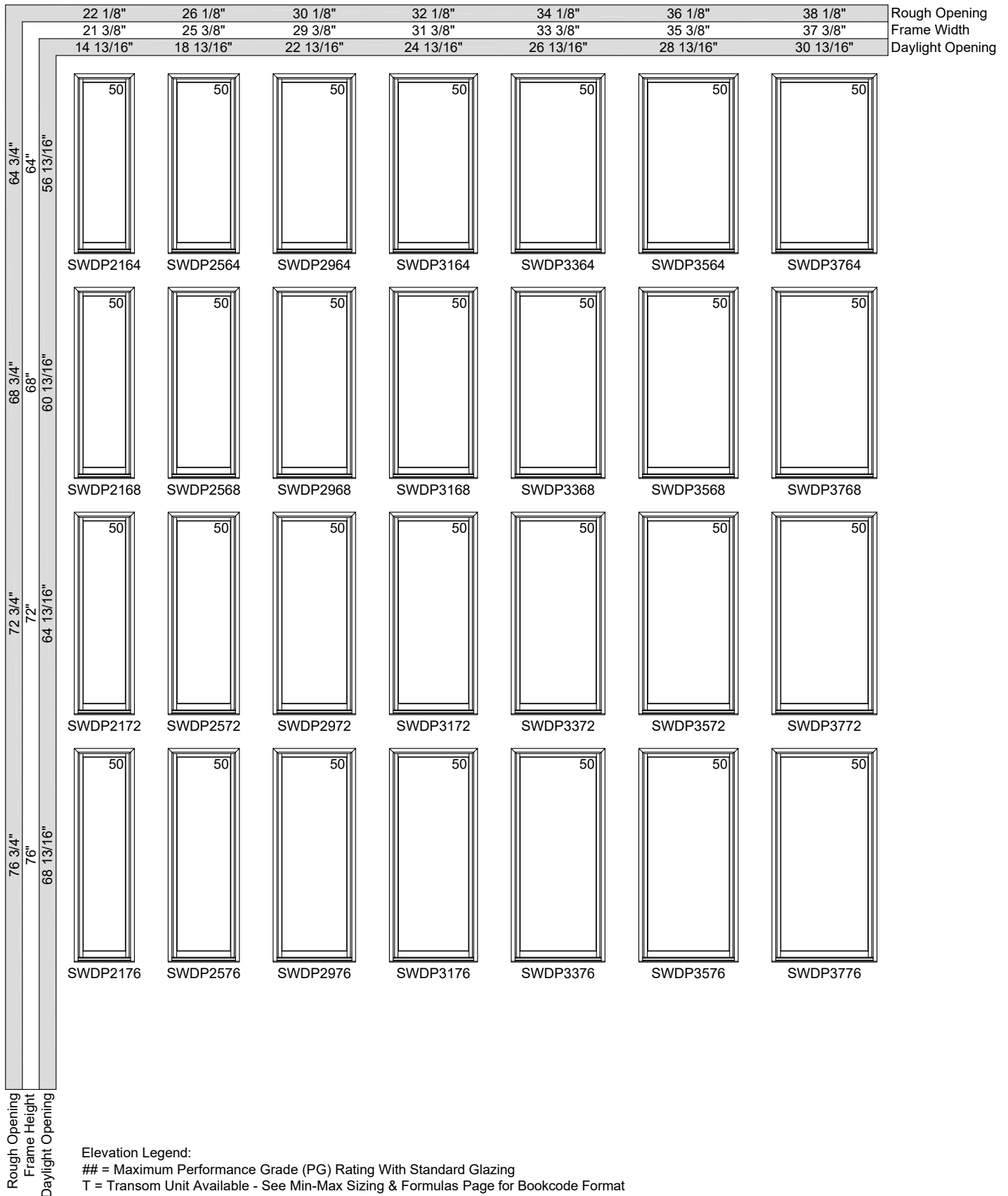

FIXED UNITS - RECTANGLE

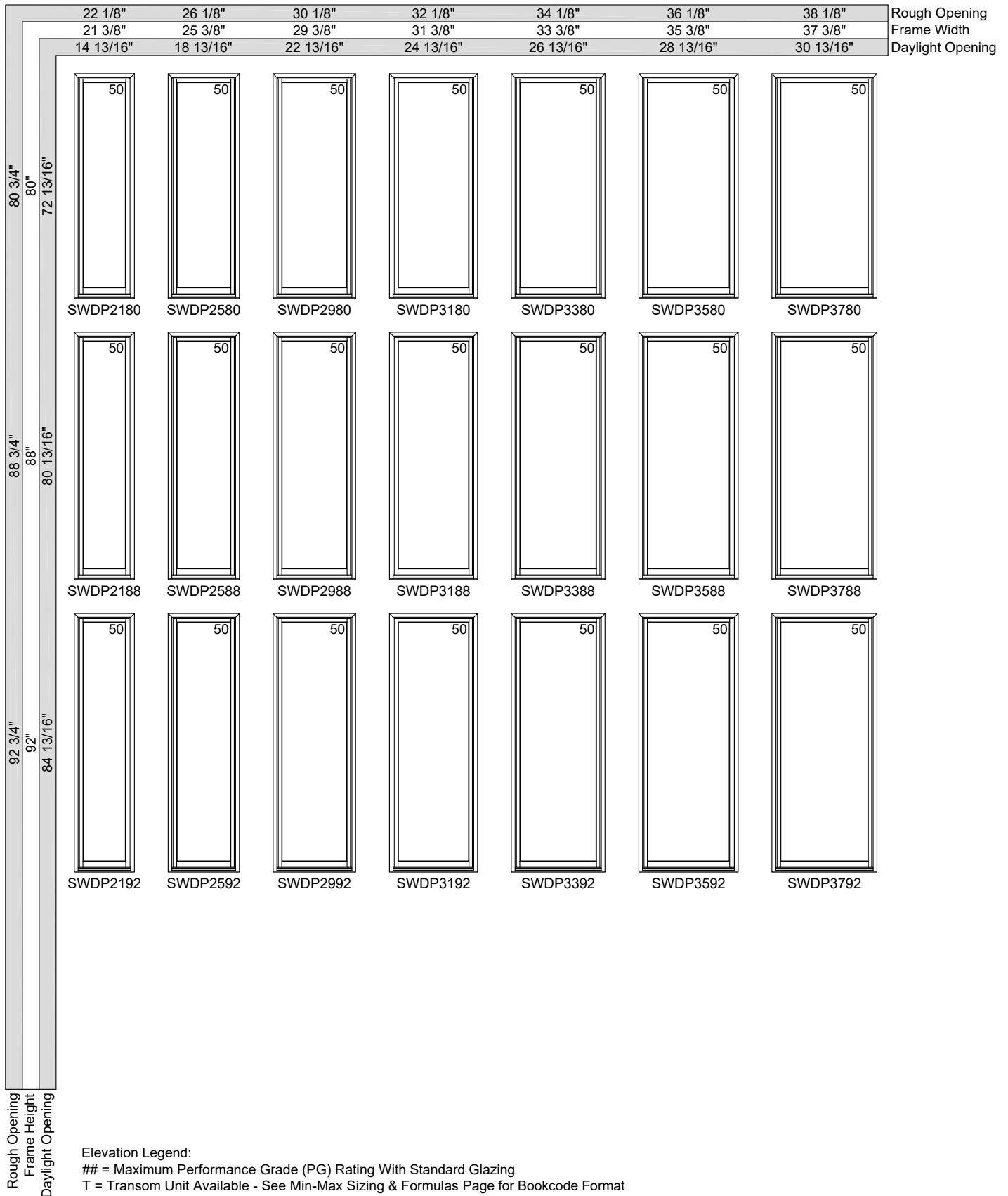

FIXED UNITS - RECTANGLE

	42 1/8"	46 1/8"	50 1/8"	54 1/8"	62 1/8"	Rough Opening
	41 3/8"	45 3/8"	49 3/8"	53 3/8"	61 3/8"	Frame Width
	34 13/16"	38 13/16"	42 13/16"	46 13/16"	54 13/16"	Daylight Opening
15 3/4"						
15"						
18 3/4"						
18"						
24 3/4"						
24"						
32 3/4"						
32"						
36 3/4"						
36"						
40 3/4"						
40"						
44 3/4"						
44"						
Rough Opening						
Frame Height						
Daylight Opening						

Elevation Legend:

= Maximum Performance Grade (PG) Rating With Standard Glazing

T = Transom Unit Available - See Min-Max Sizing & Formulas Page for Bookcode Format

FIXED UNITS - RECTANGLE

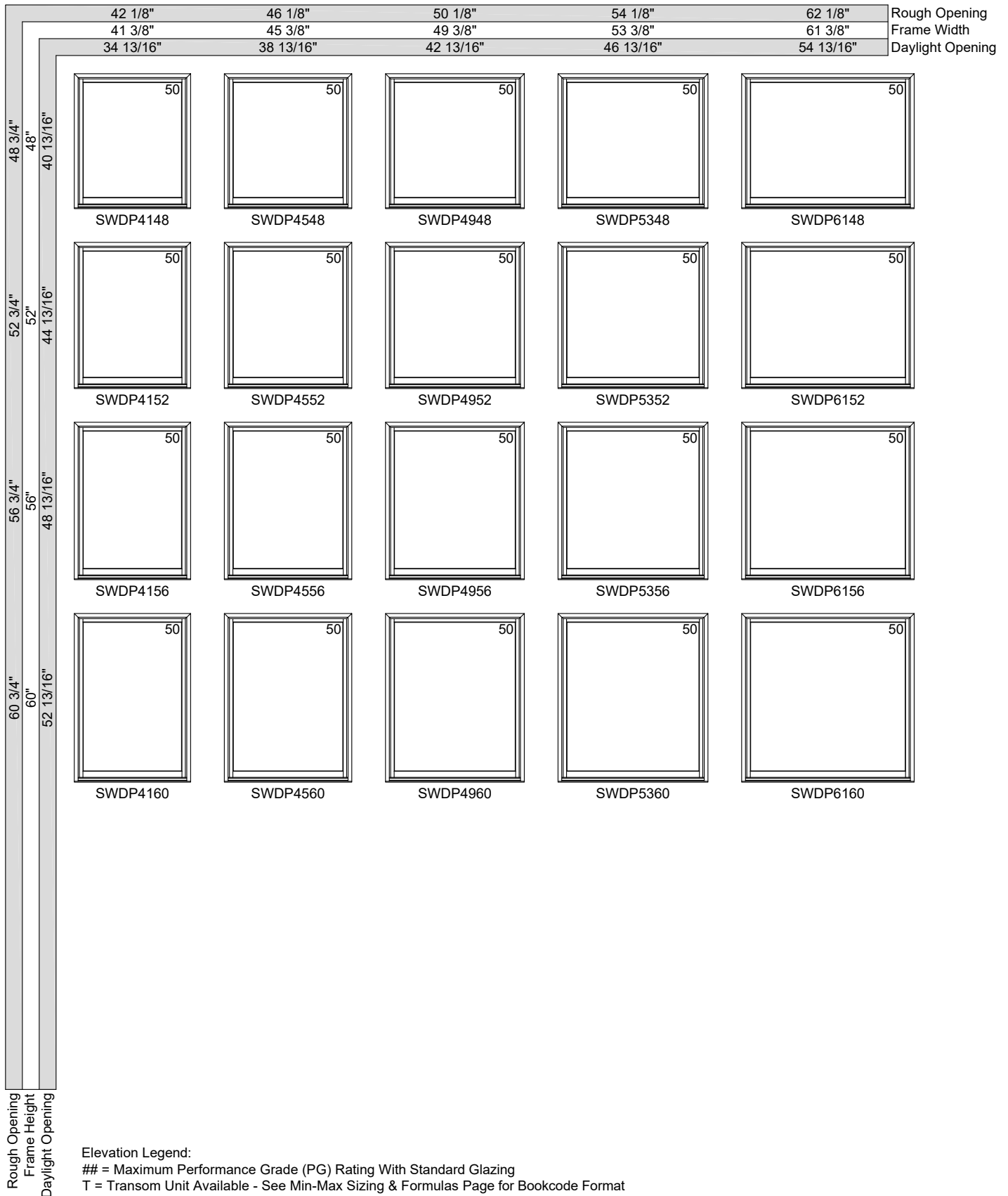

FIXED UNITS - RECTANGLE

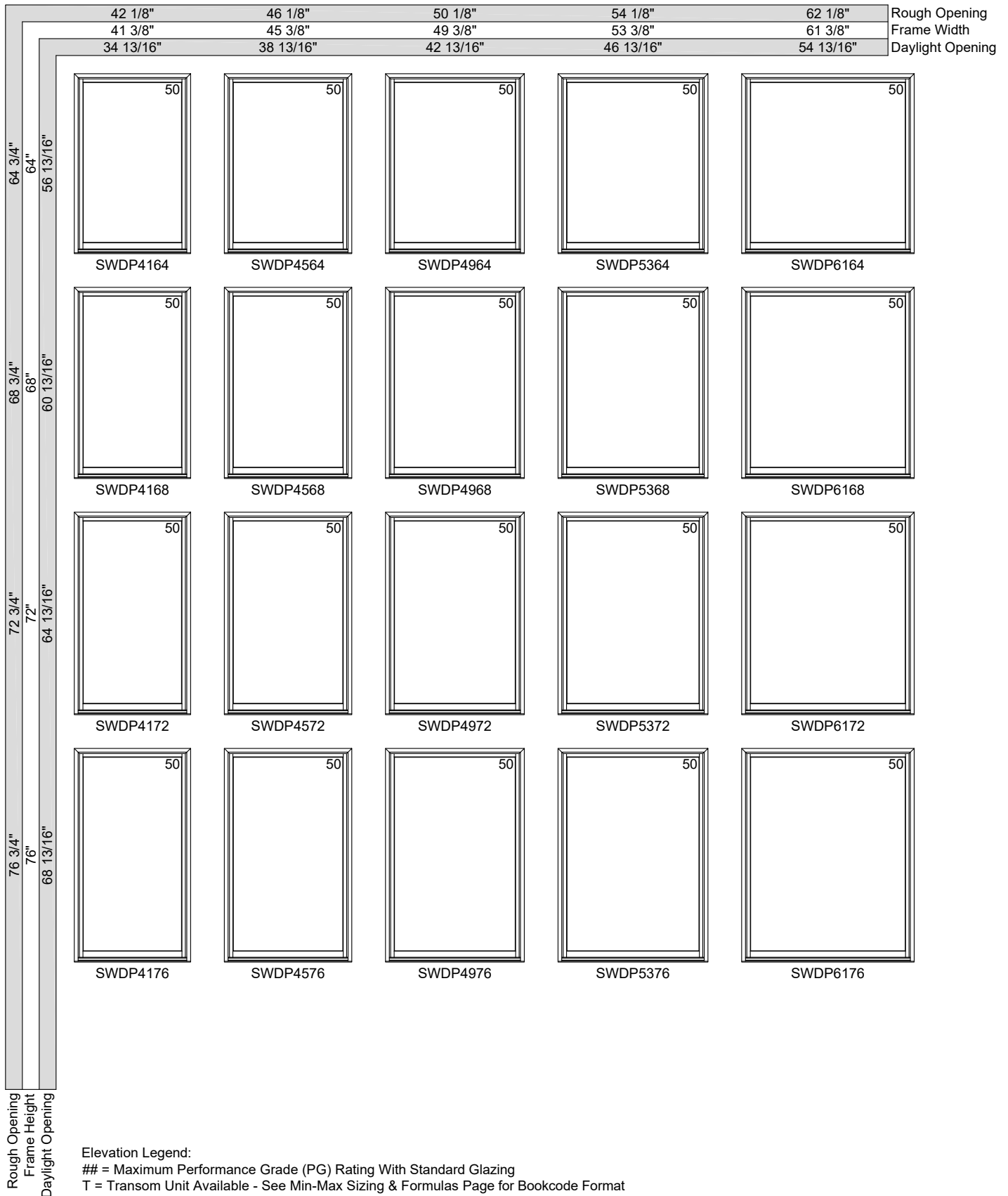

FIXED UNITS - RECTANGLE

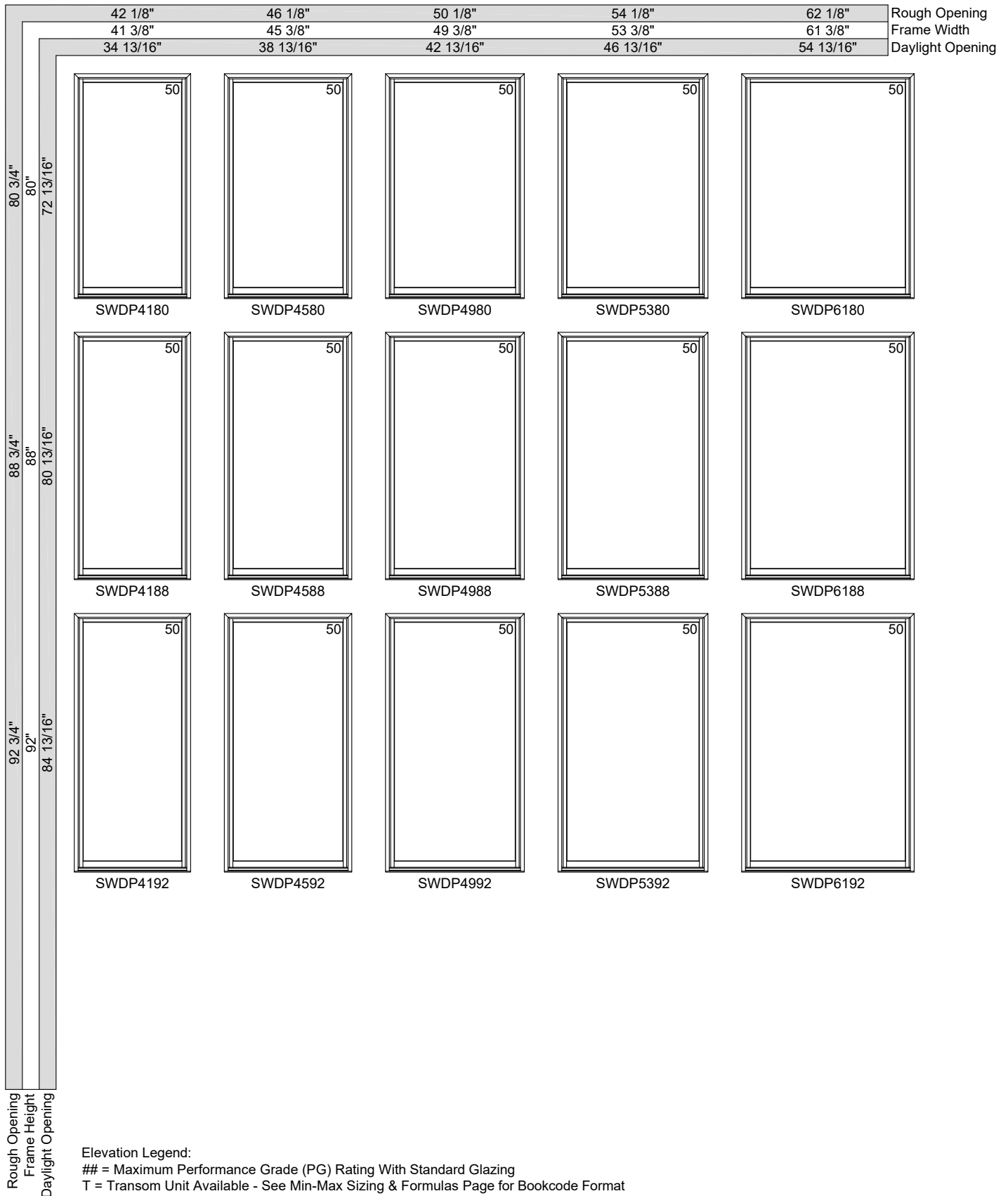

FIXED UNITS - RECTANGLE

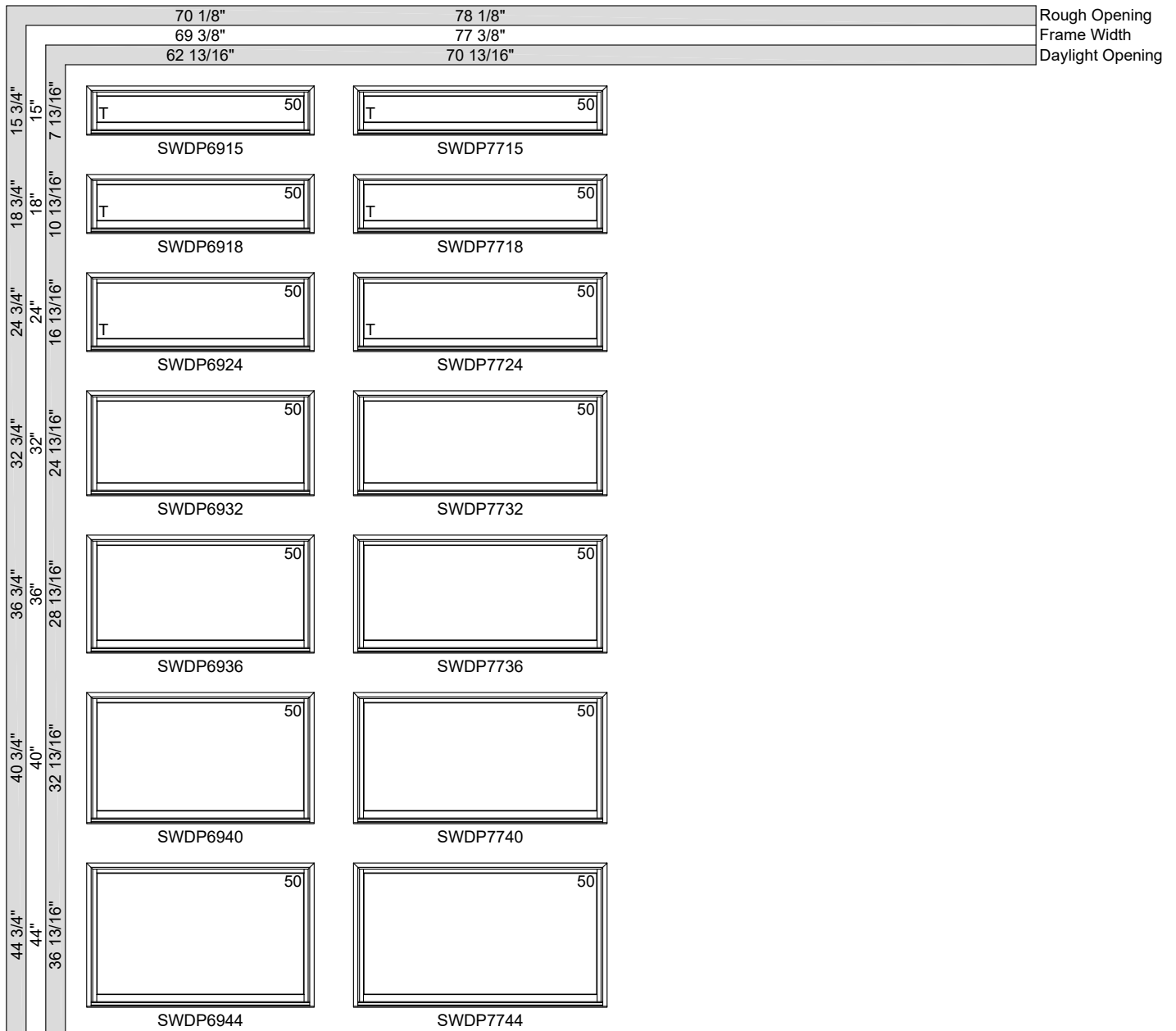

Rough Opening
Frame Height
Daylight Opening

Legend:
 # - Maximum Performance Glazing
 T - Transom Available - See Min-Max Sizing & Formulas Page for Bookcode Format
 50 - 50 Series Glazing

FIXED UNITS - RECTANGLE

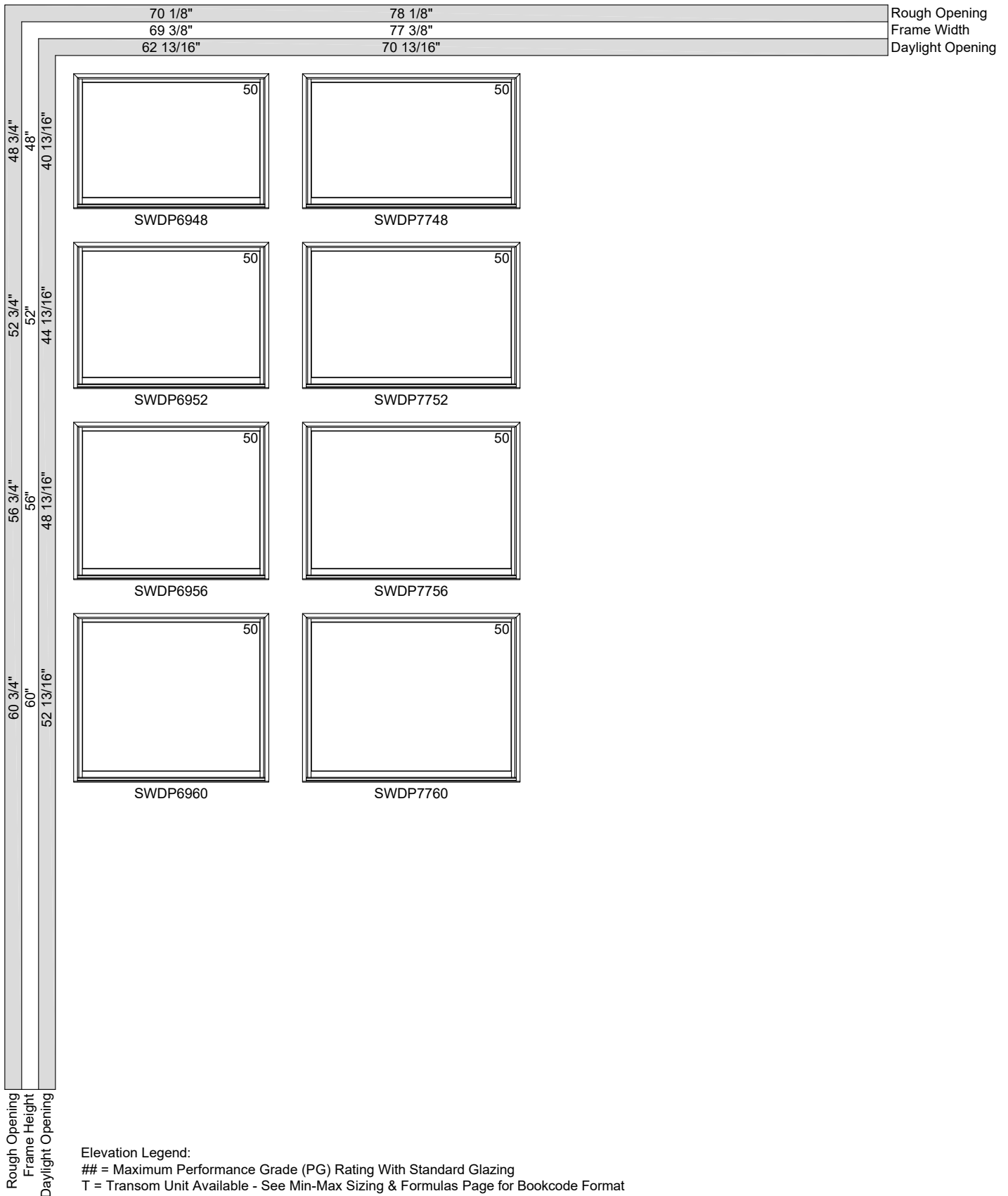



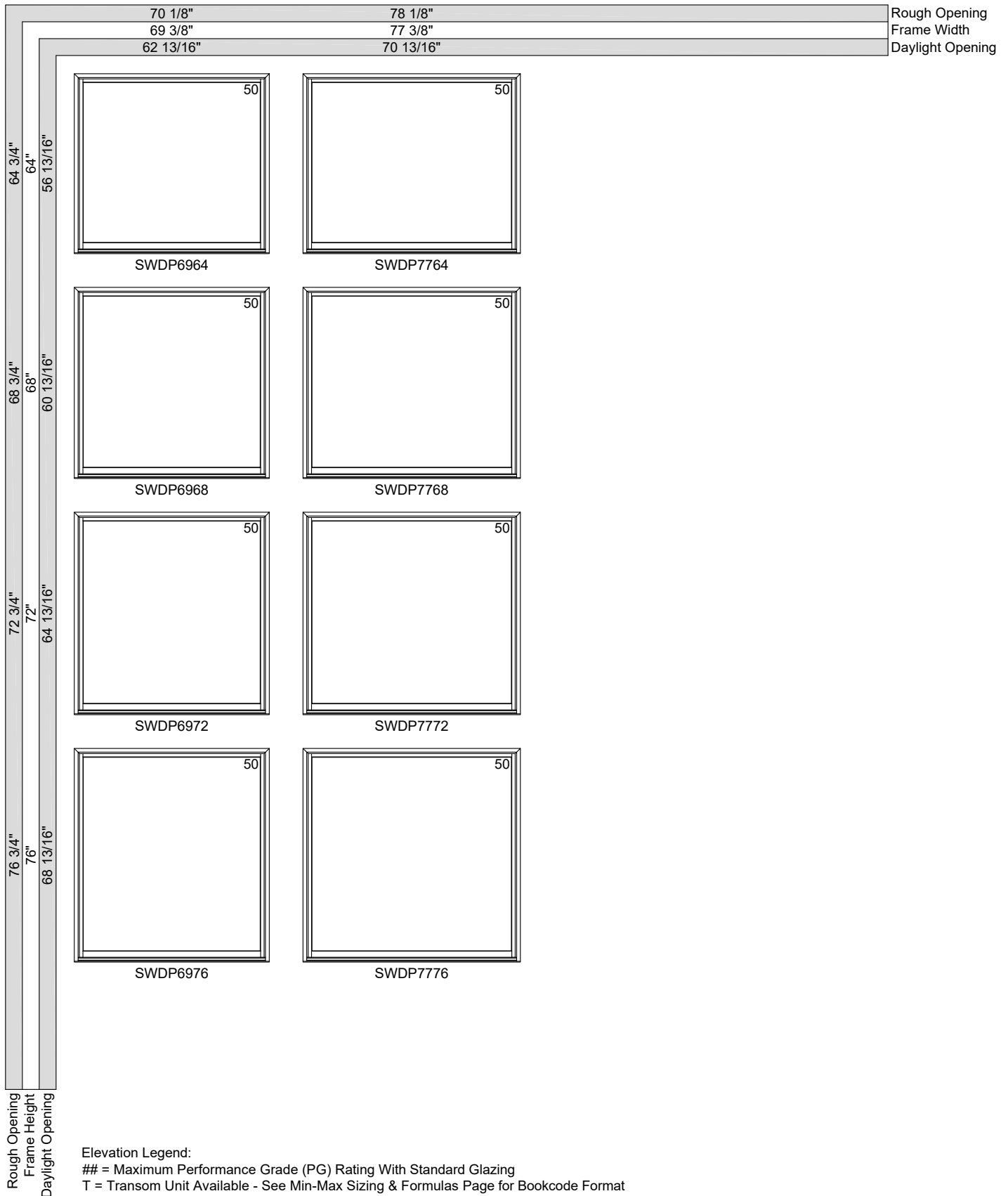



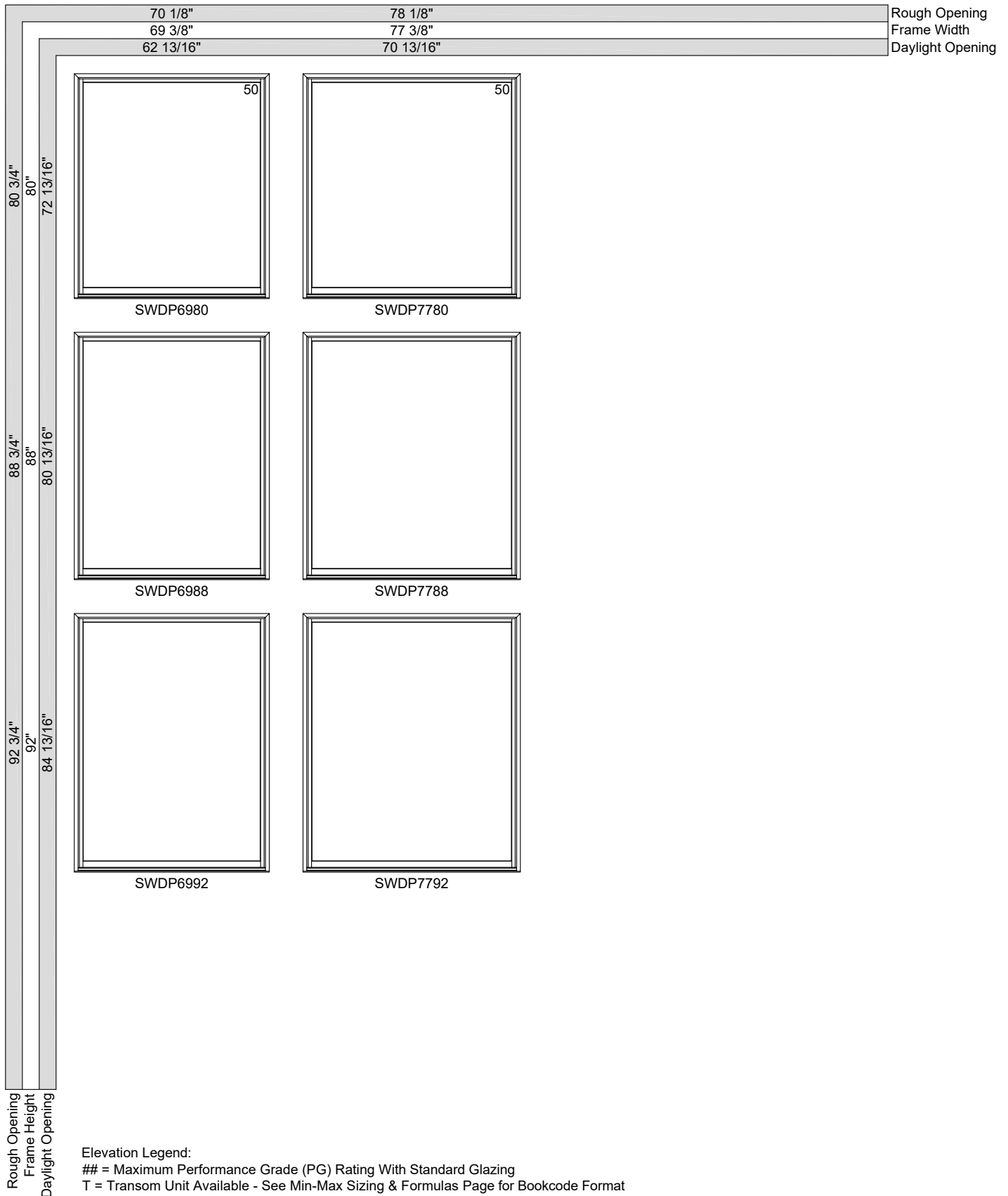

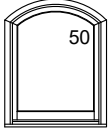
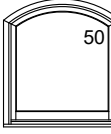

FIXED UNITS - RECTANGLE

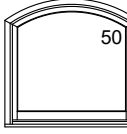
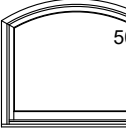
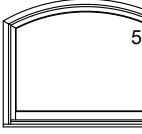
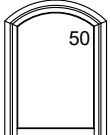
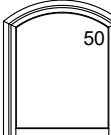

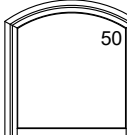
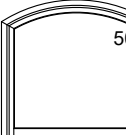
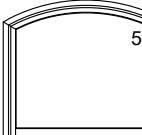
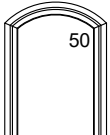
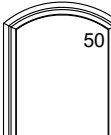
FIXED UNITS - RECTANGLE

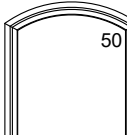
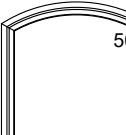
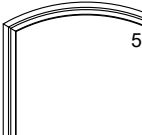
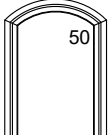
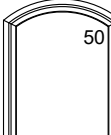

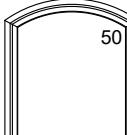
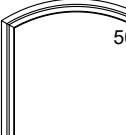
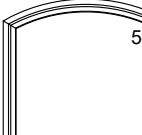
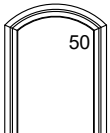
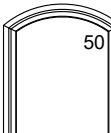
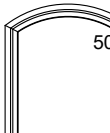
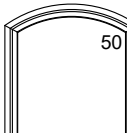
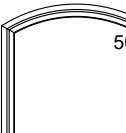
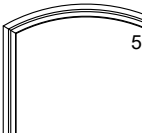
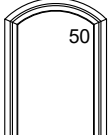
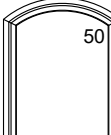
FIXED UNITS - EXTENDED CIRCLE SEGMENT

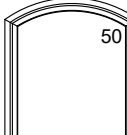
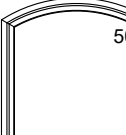
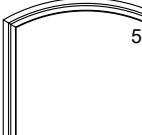
	26 1/8"	30 1/8"	32 1/8"	34 1/8"	38 1/8"	42 1/8"	Rough Opening
	25 3/8"	29 3/8"	31 3/8"	33 3/8"	37 3/8"	41 3/8"	Frame Width
	18 13/16"	22 13/16"	24 13/16"	26 13/16"	30 13/16"	34 13/16"	Daylight Opening
32 3/4"							
32"							
36 3/4"							
36"							
40 3/4"							
40"							
44 3/4"							
44"							
48 3/4"							
48"							
52 3/4"							
52"							
44 13/16"							

Rough Opening
Frame Height
Daylight Opening

Elevation Legend:
= Maximum Performance Grade (PG) Rating With Standard Glazing
Leg Height = Frame Height - 6"

FIXED UNITS - EXTENDED CIRCLE SEGMENT

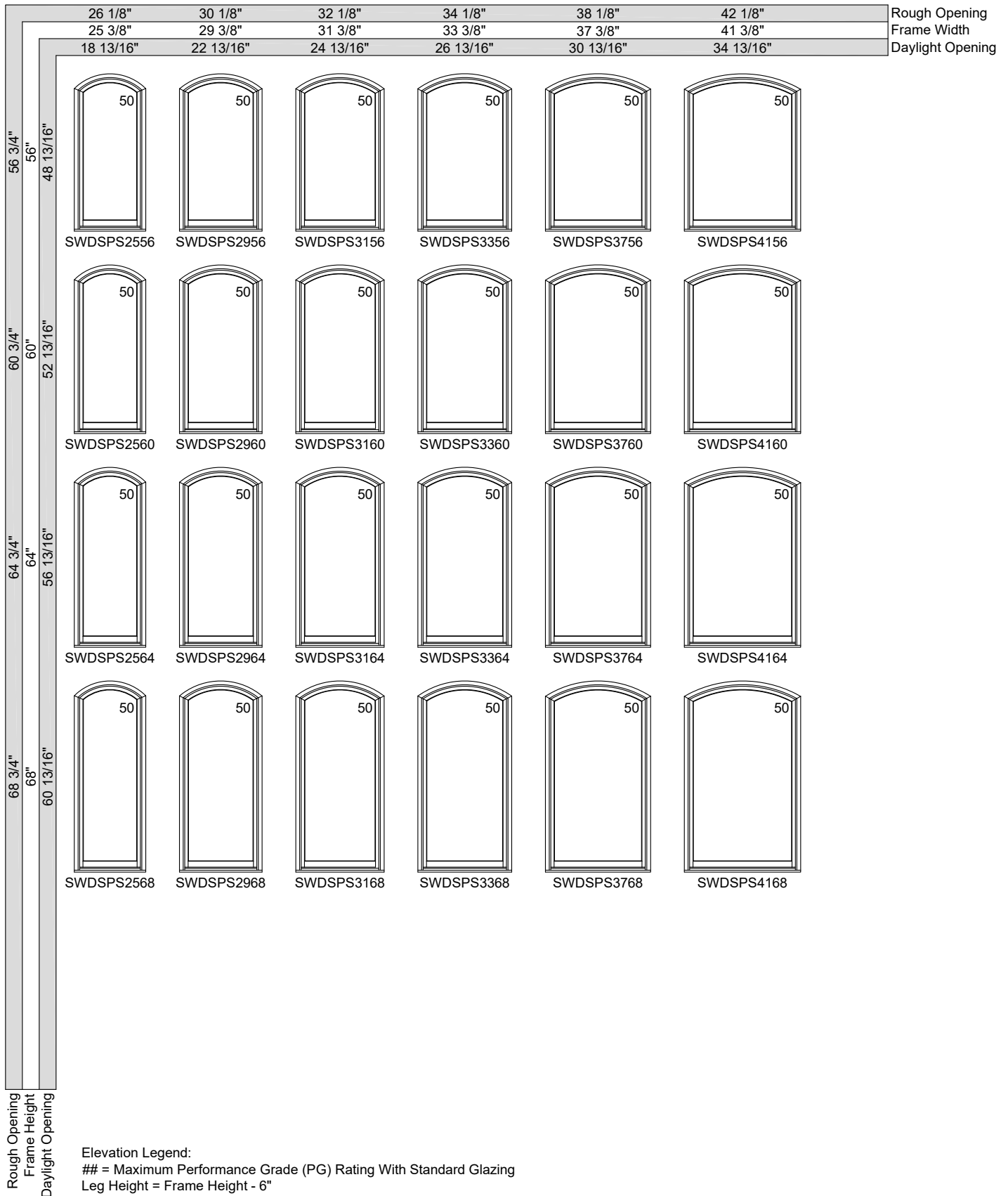

FIXED UNITS - EXTENDED CIRCLE SEGMENT

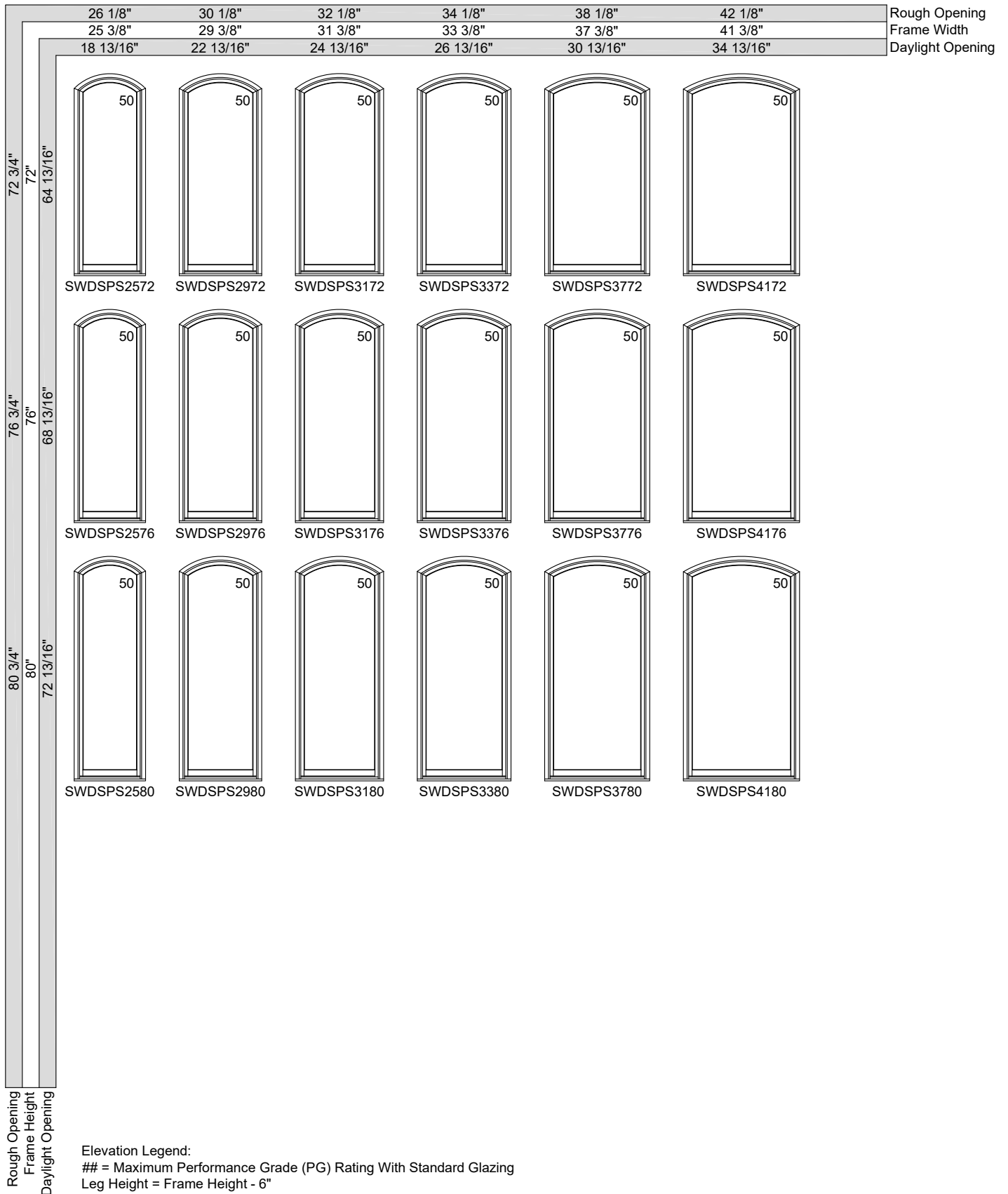

FIXED UNITS - EXTENDED CIRCLE SEGMENT

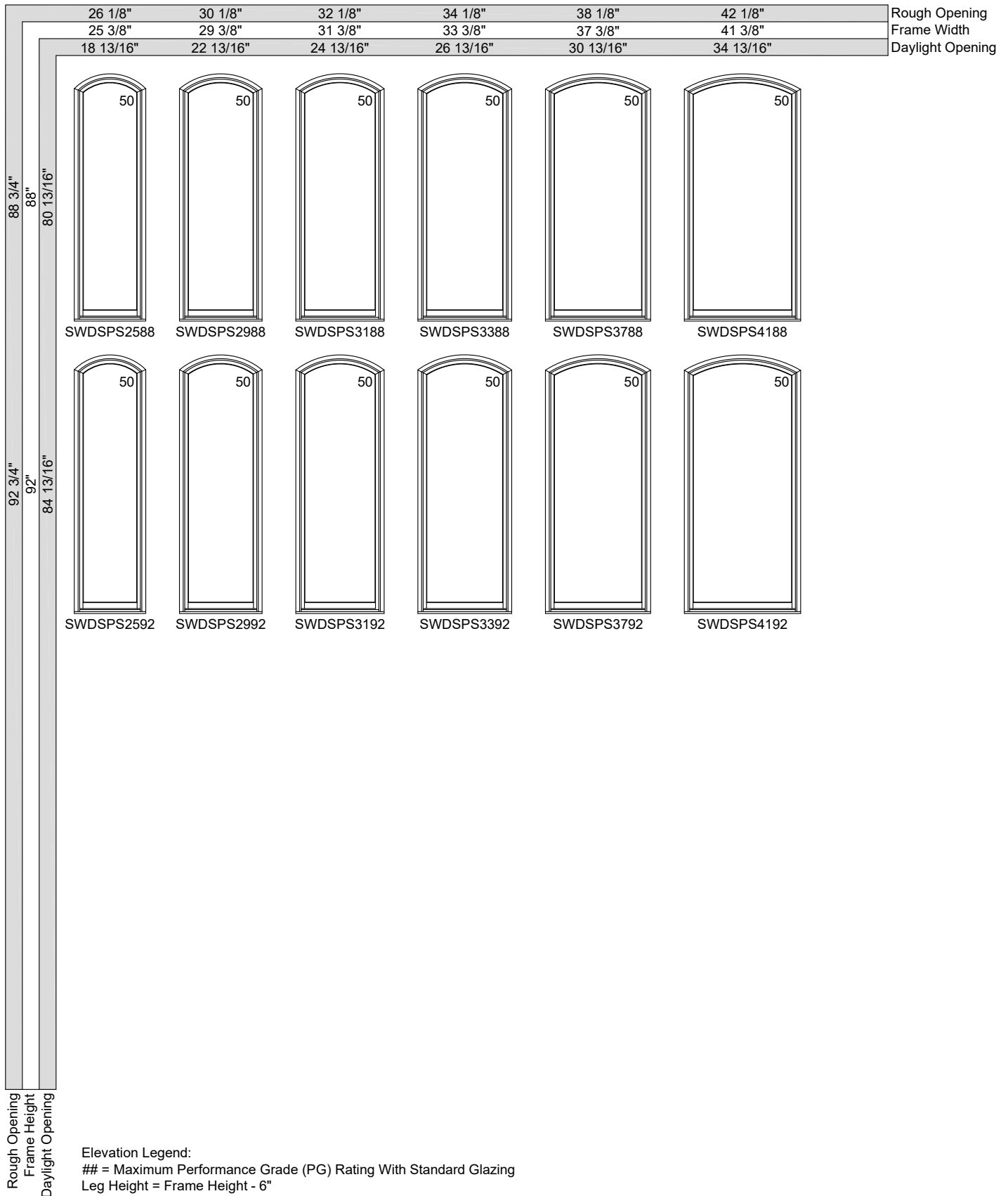

FIXED UNITS - EXTENDED CIRCLE SEGMENT

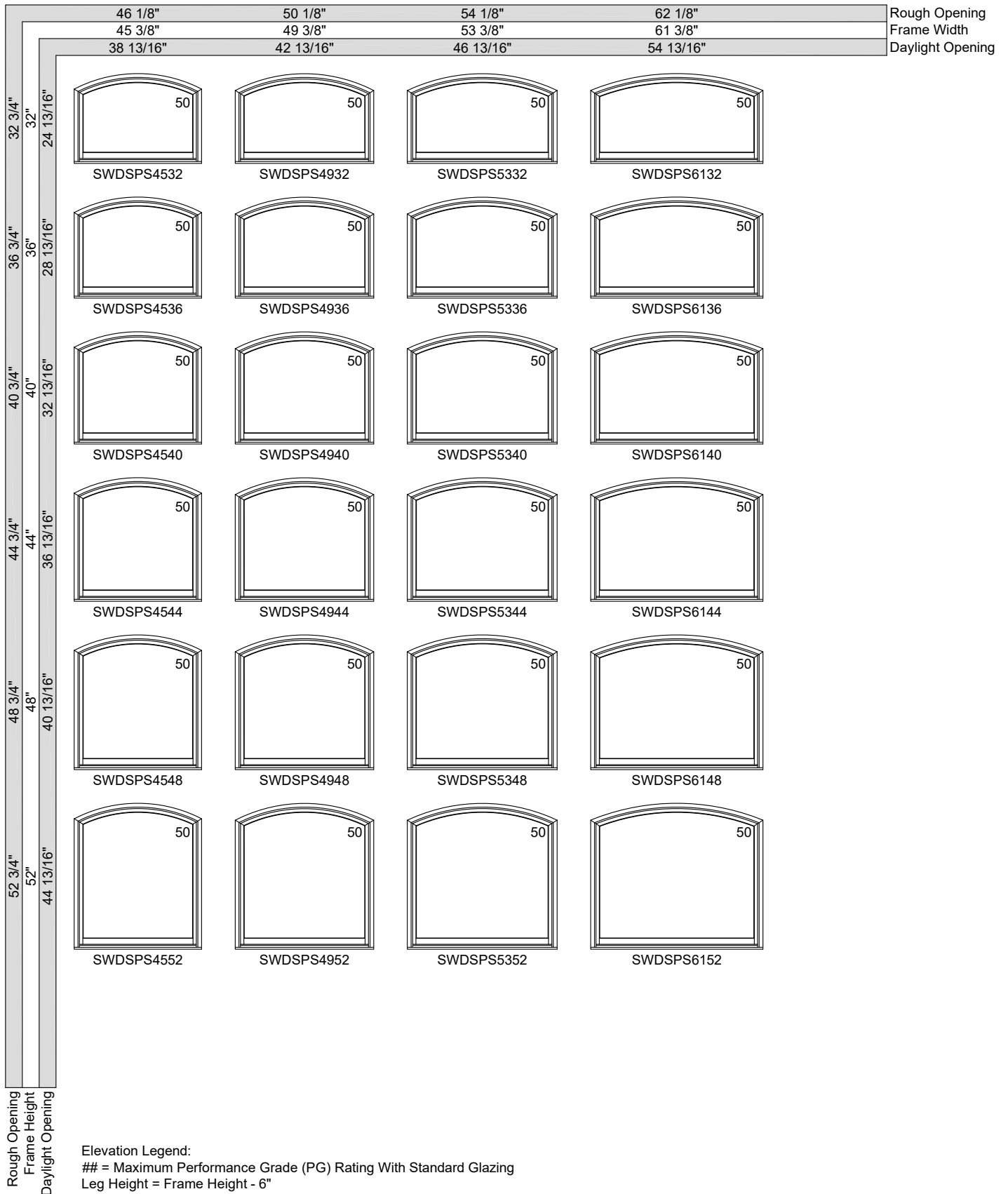

FIXED UNITS - EXTENDED CIRCLE SEGMENT

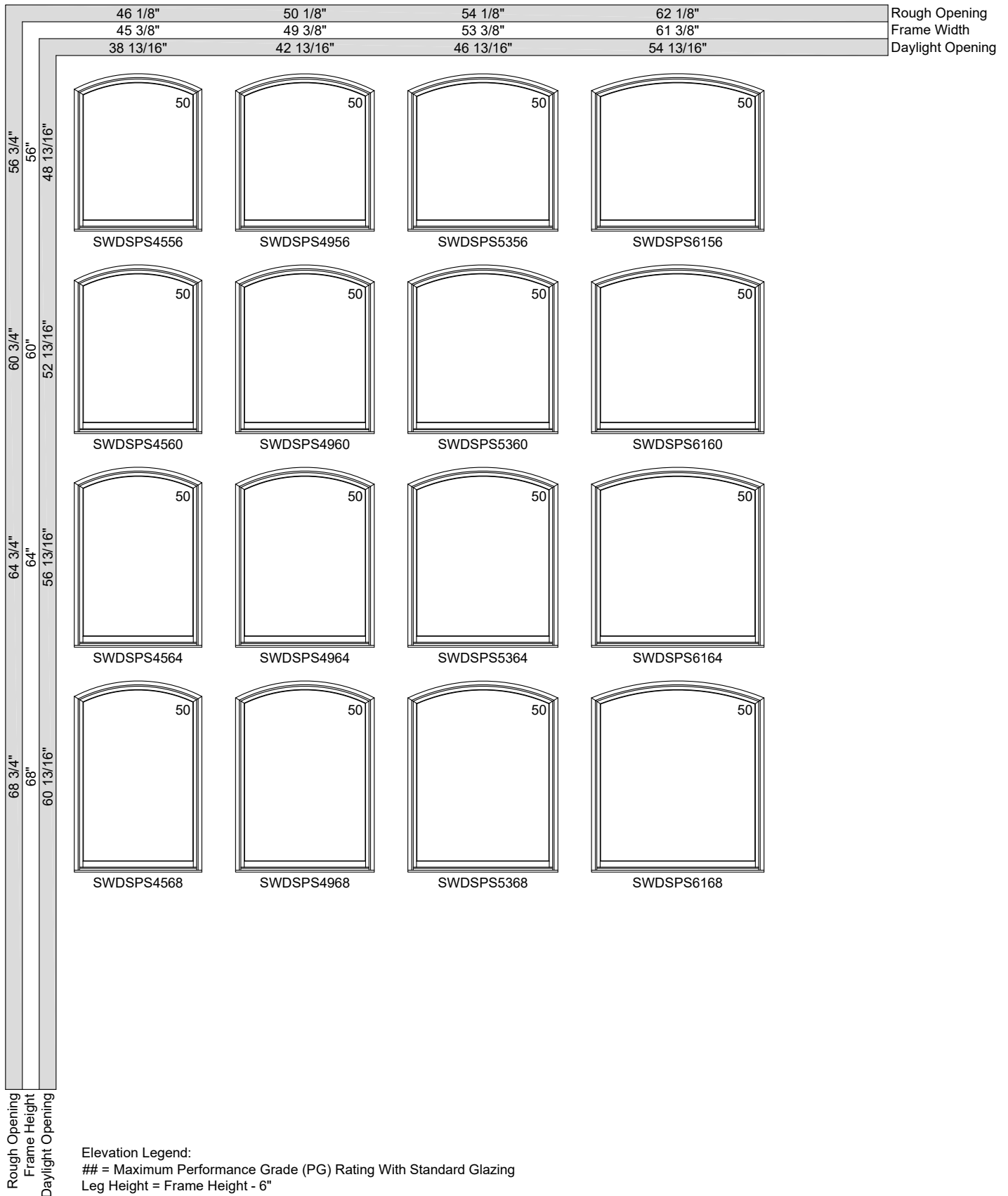

FIXED UNITS - EXTENDED CIRCLE SEGMENT

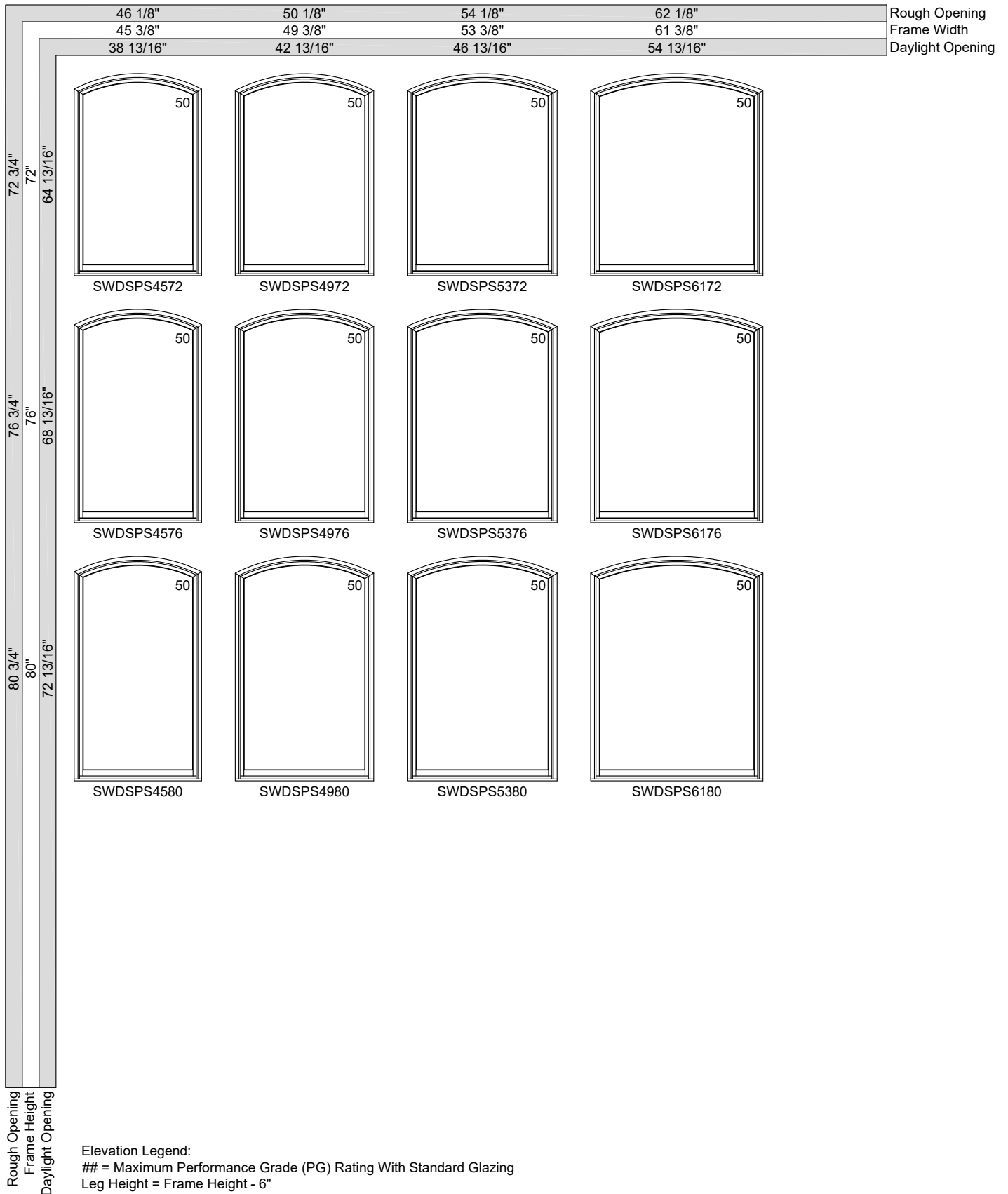

FIXED UNITS - EXTENDED CIRCLE SEGMENT

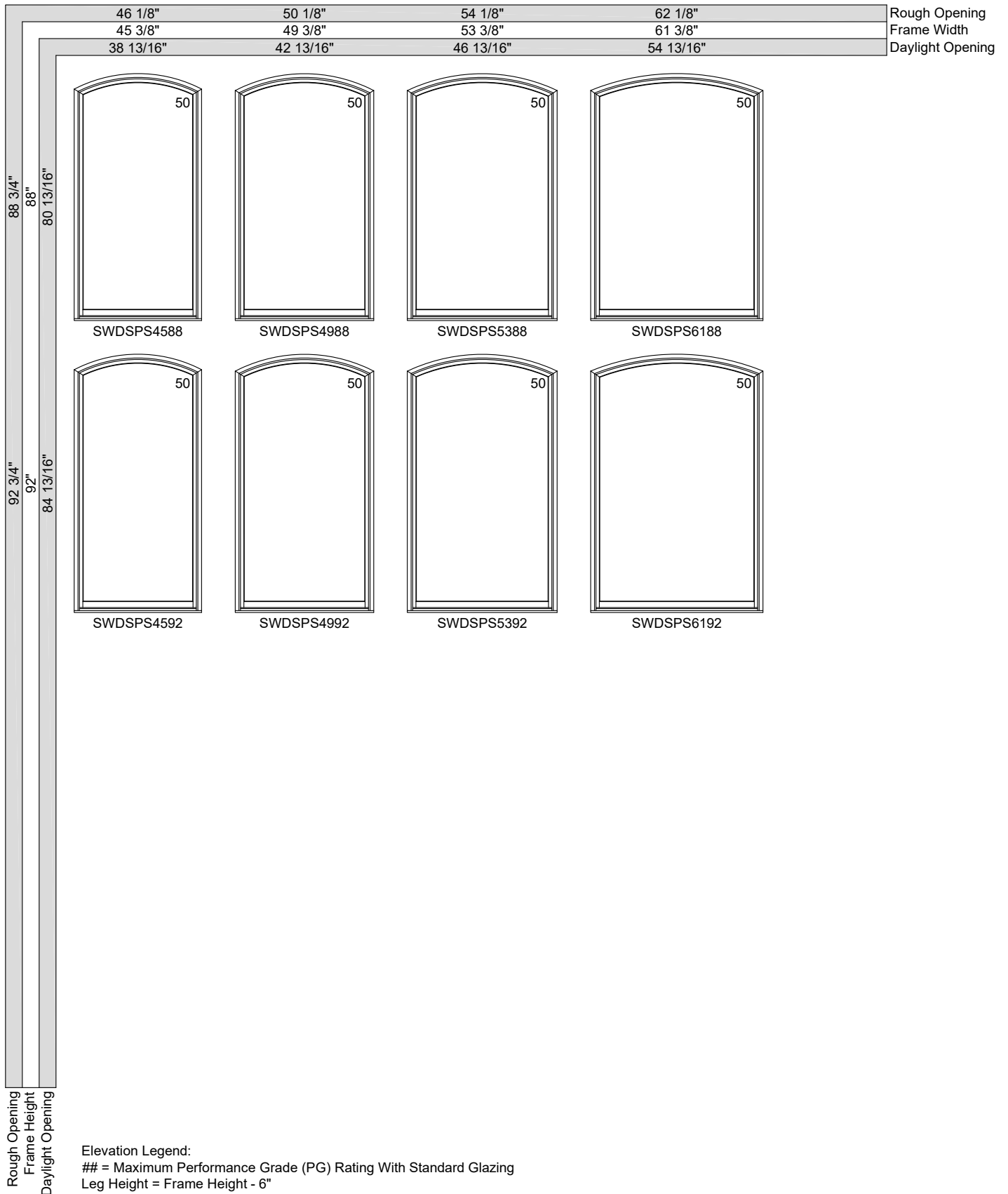

FIXED UNITS - EXTENDED CIRCLE SEGMENT

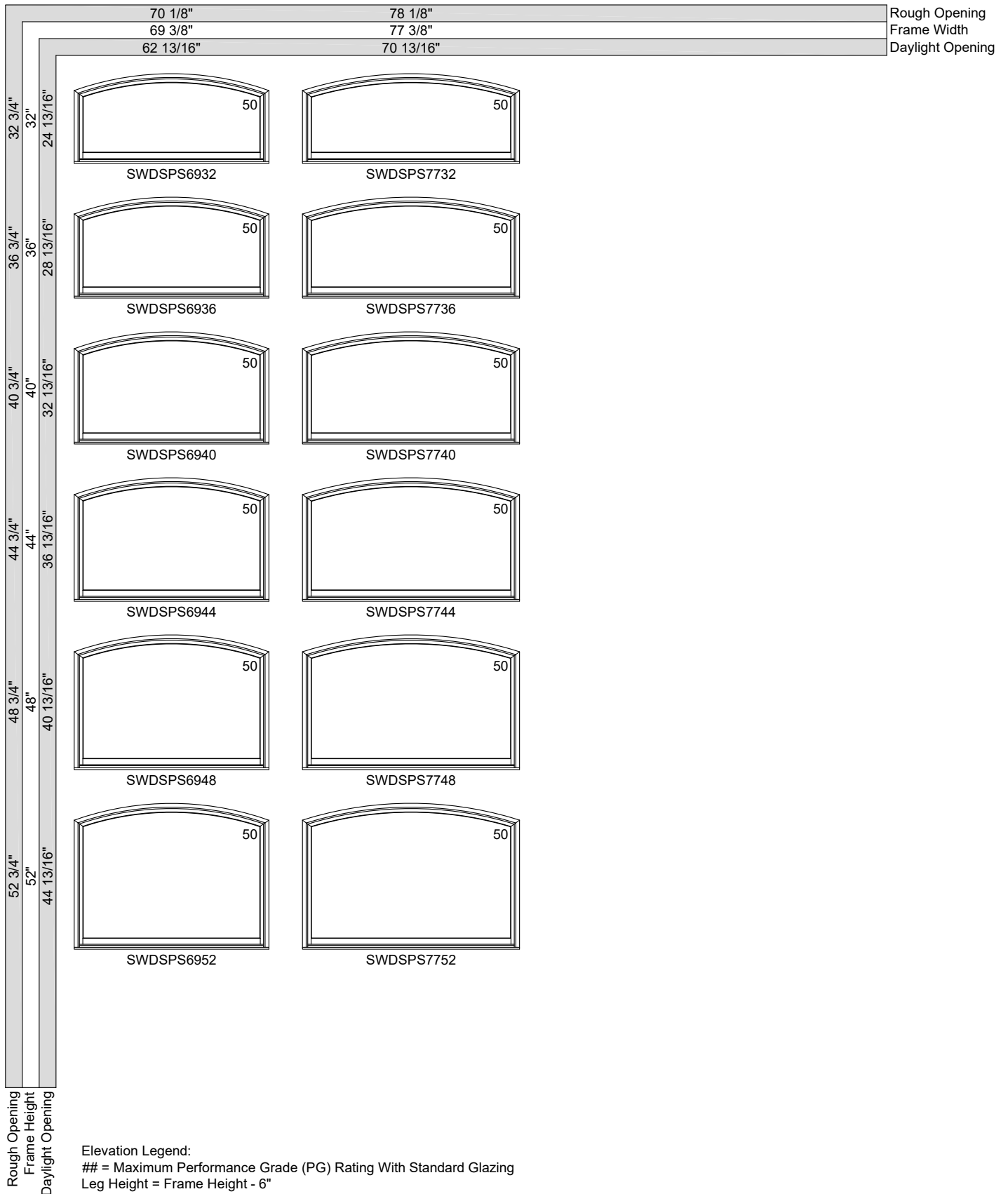

FIXED UNITS - EXTENDED CIRCLE SEGMENT

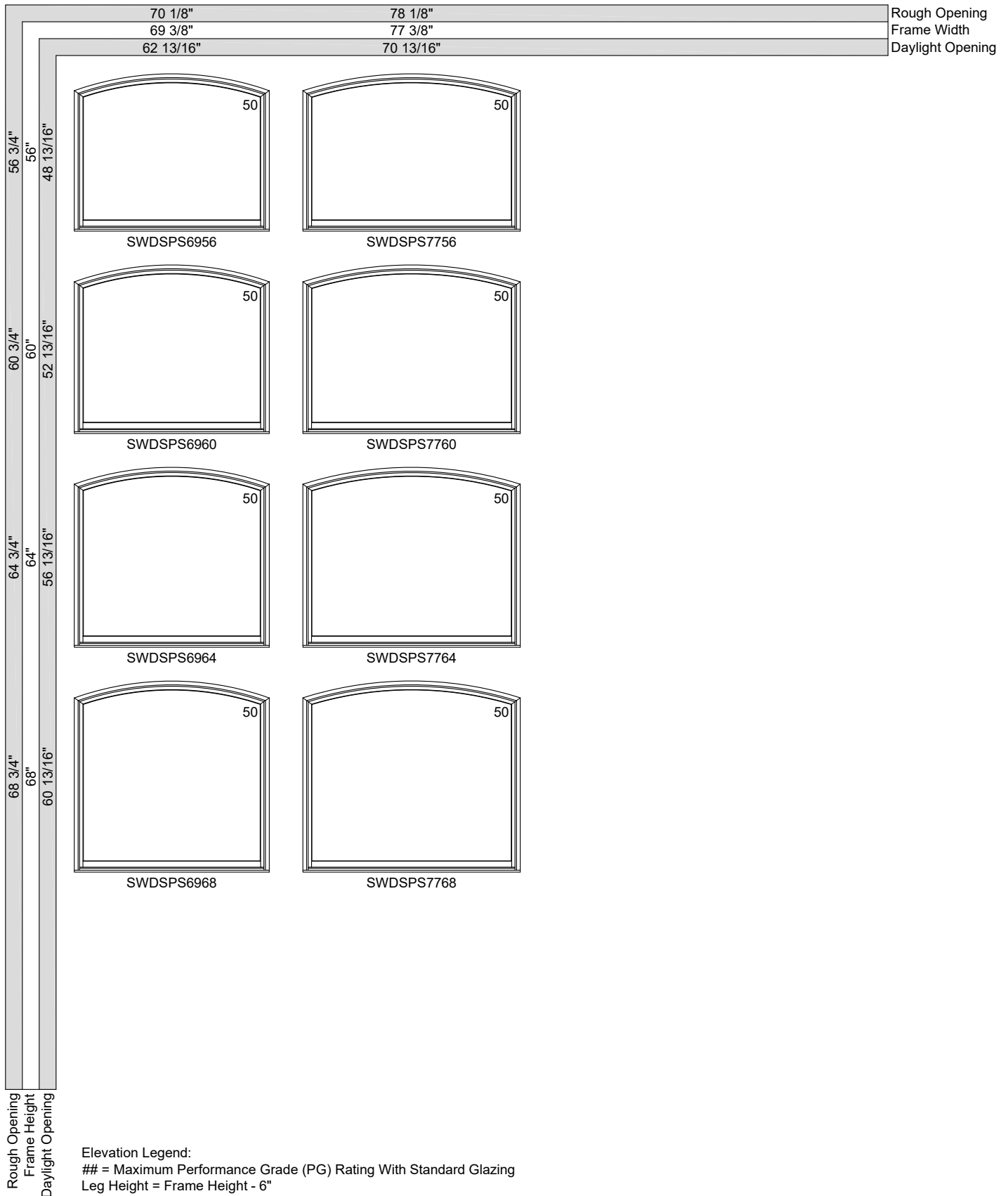



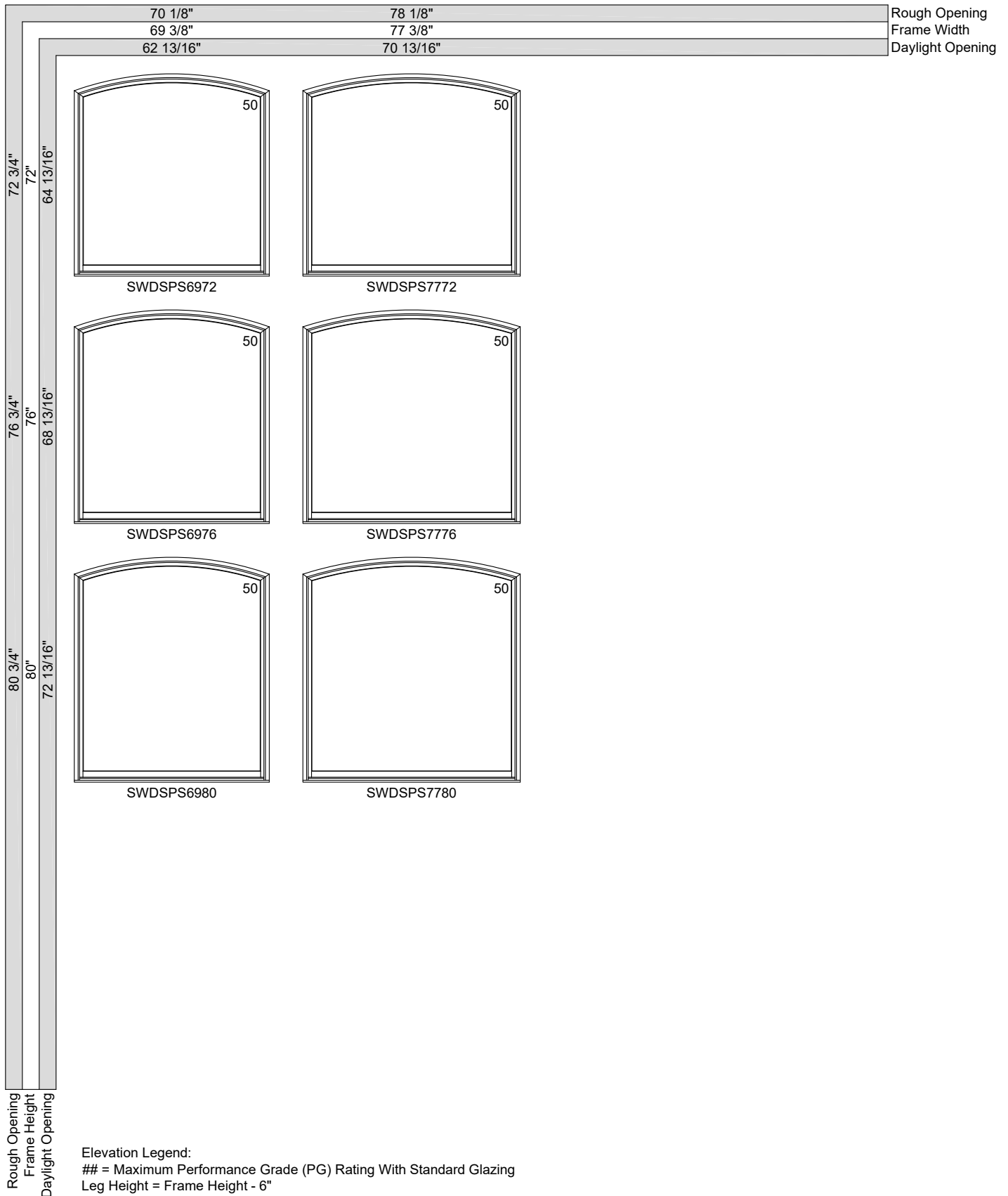



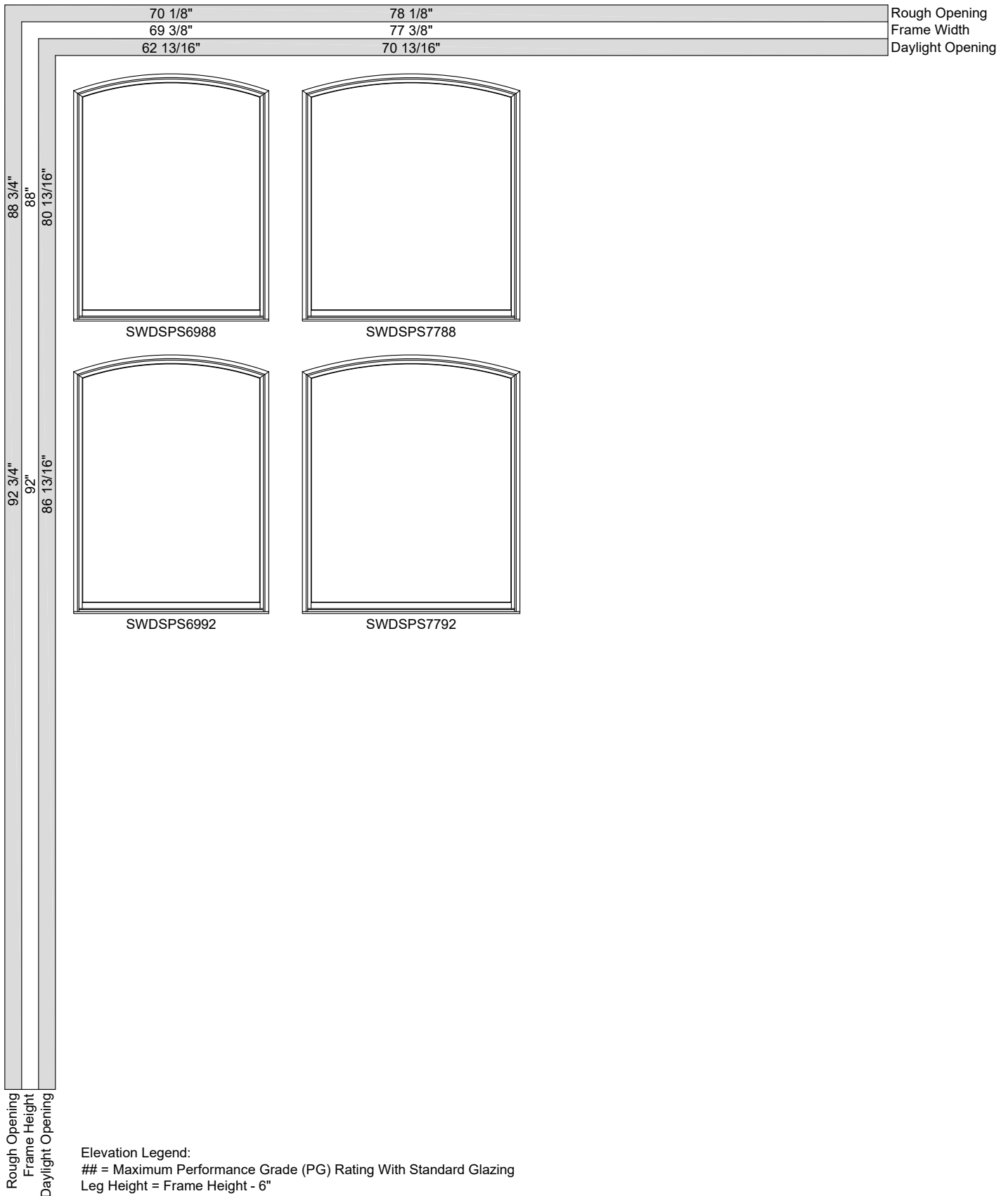

FIXED UNITS - EXTENDED CIRCLE SEGMENT

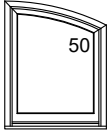
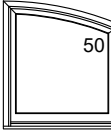
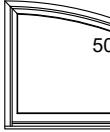
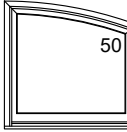
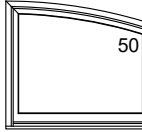
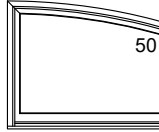
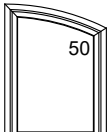
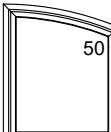
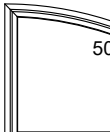
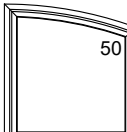
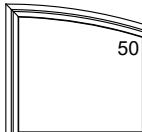
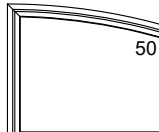
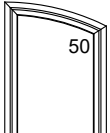
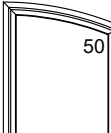
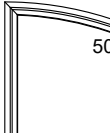
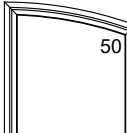
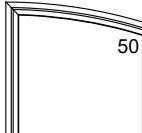
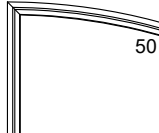
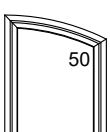
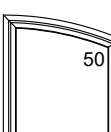
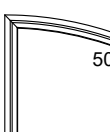
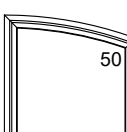
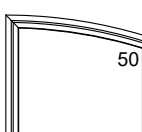
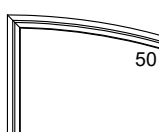
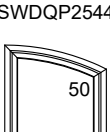

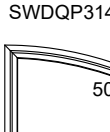
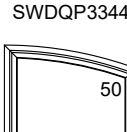
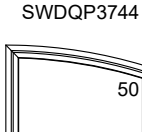
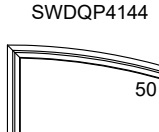
FIXED UNITS - EXTENDED CIRCLE SEGMENT



FIXED UNITS - EXTENDED QUARTER SEGMENT

	26 1/8"	30 1/8"	32 1/8"	34 1/8"	38 1/8"	42 1/8"	Rough Opening
	25 3/8"	29 3/8"	31 3/8"	33 3/8"	37 3/8"	41 3/8"	Frame Width
	18 13/16"	22 13/16"	24 13/16"	26 13/16"	30 13/16"	34 13/16"	Daylight Opening
32 3/4"							
36 3/4"							
40 3/4"							
44 3/4"							
48 3/4"							
52 3/4"							

Rough Opening
Frame Height
Daylight Opening

Elevation Legend:
= Maximum Performance Grade (PG) Rating With Standard Glazing
Leg Height = Frame Height - 6"

FIXED UNITS - EXTENDED QUARTER SEGMENT

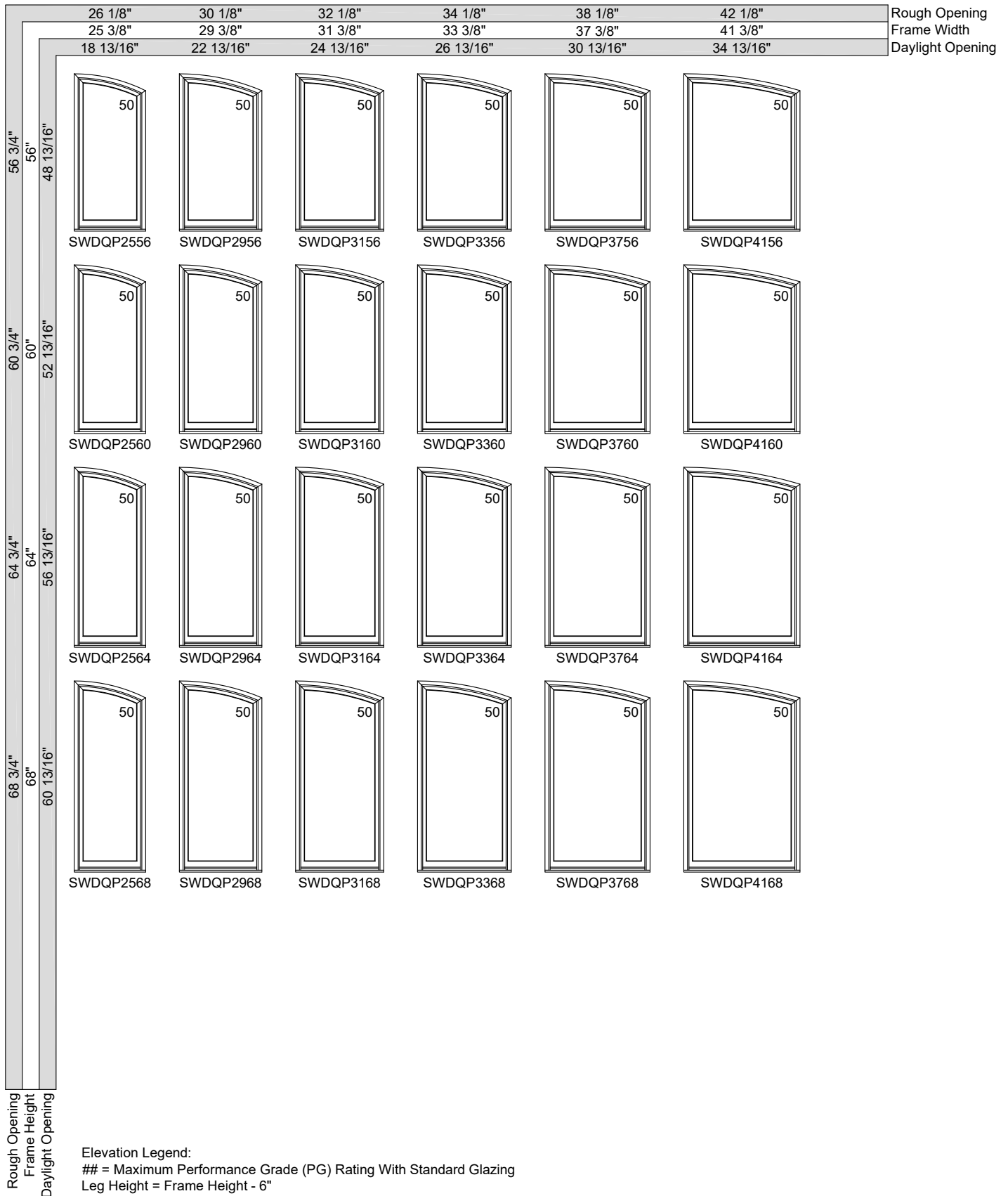

FIXED UNITS - EXTENDED QUARTER SEGMENT

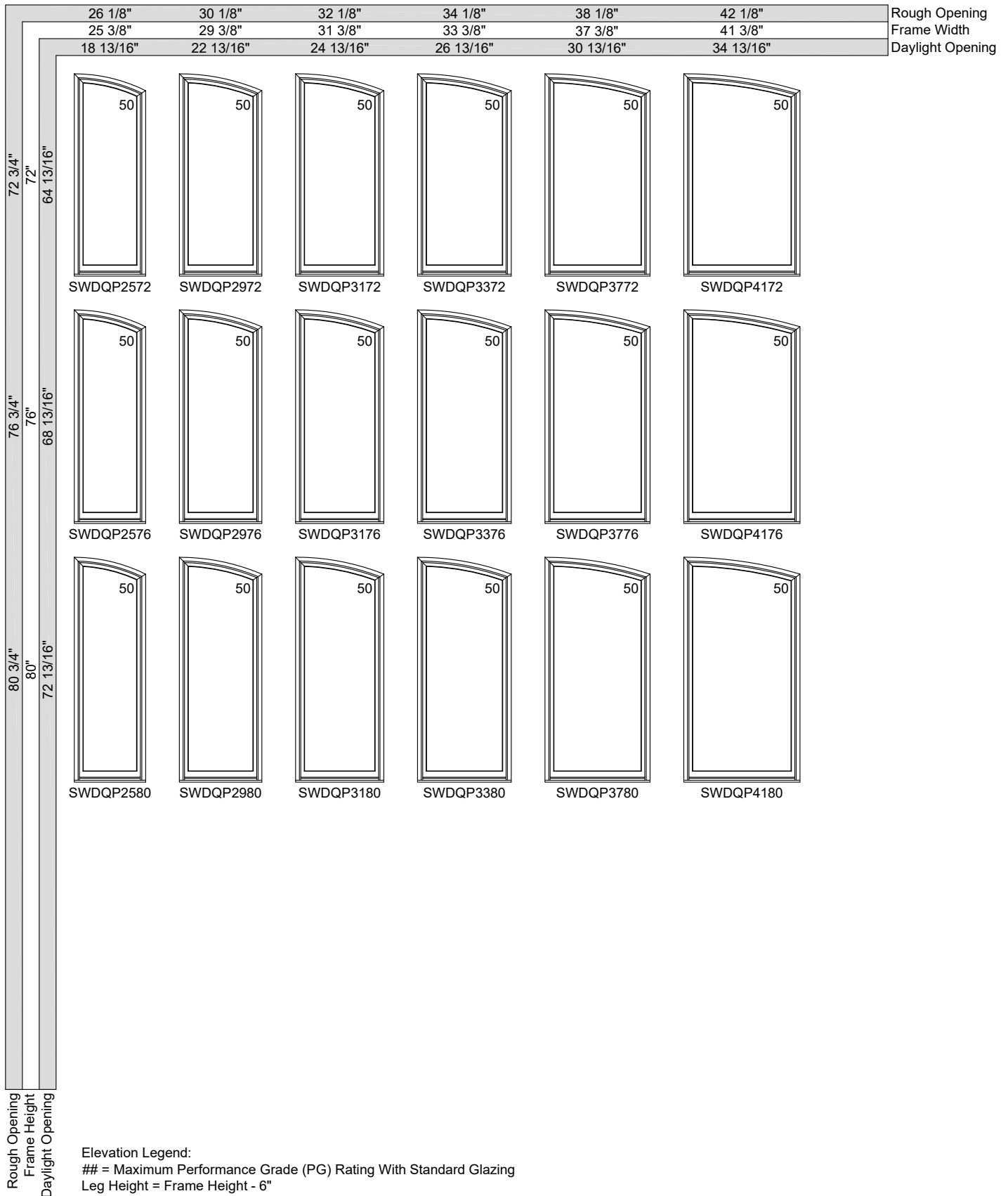

FIXED UNITS - EXTENDED QUARTER SEGMENT

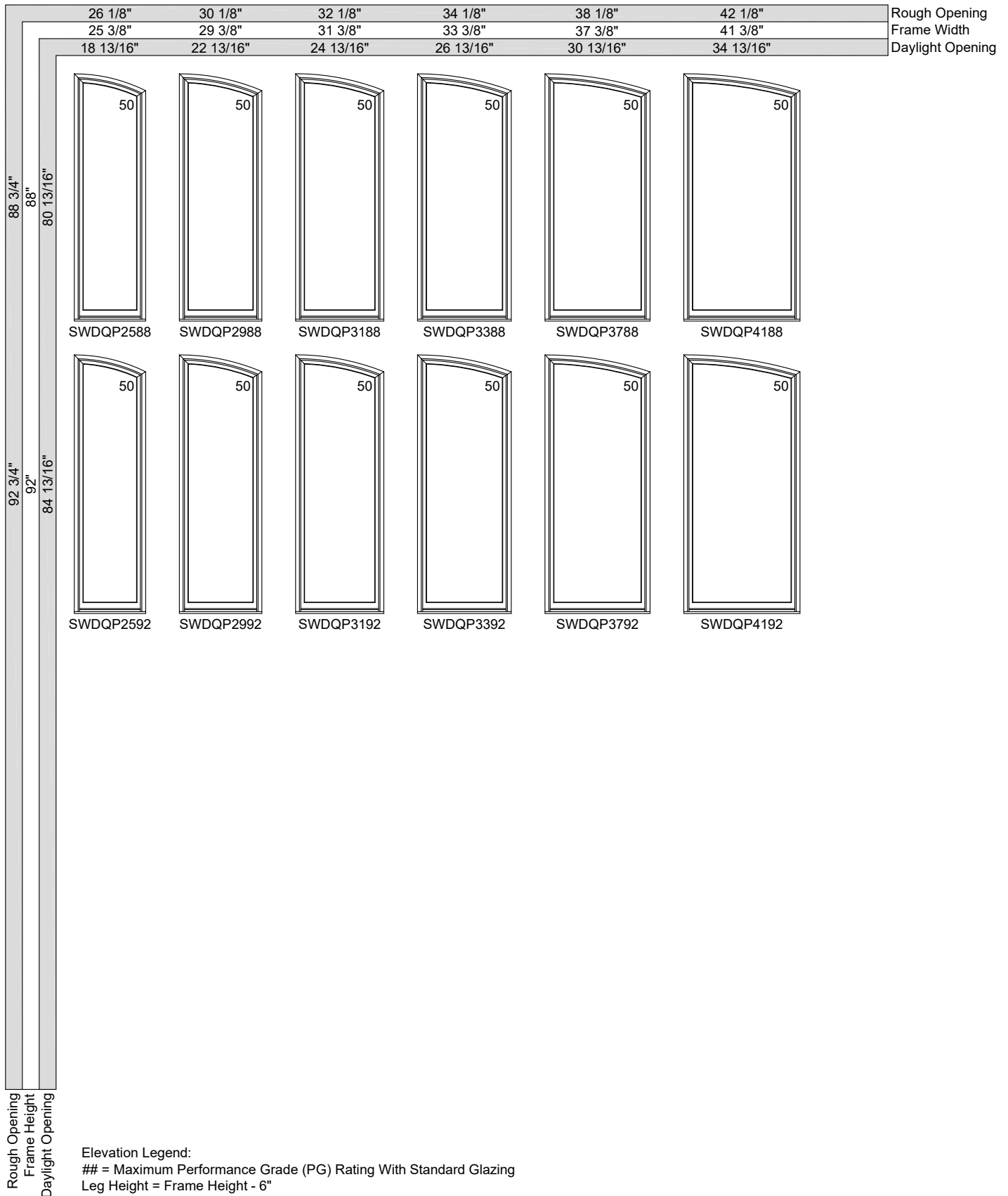

FIXED UNITS - EXTENDED QUARTER SEGMENT

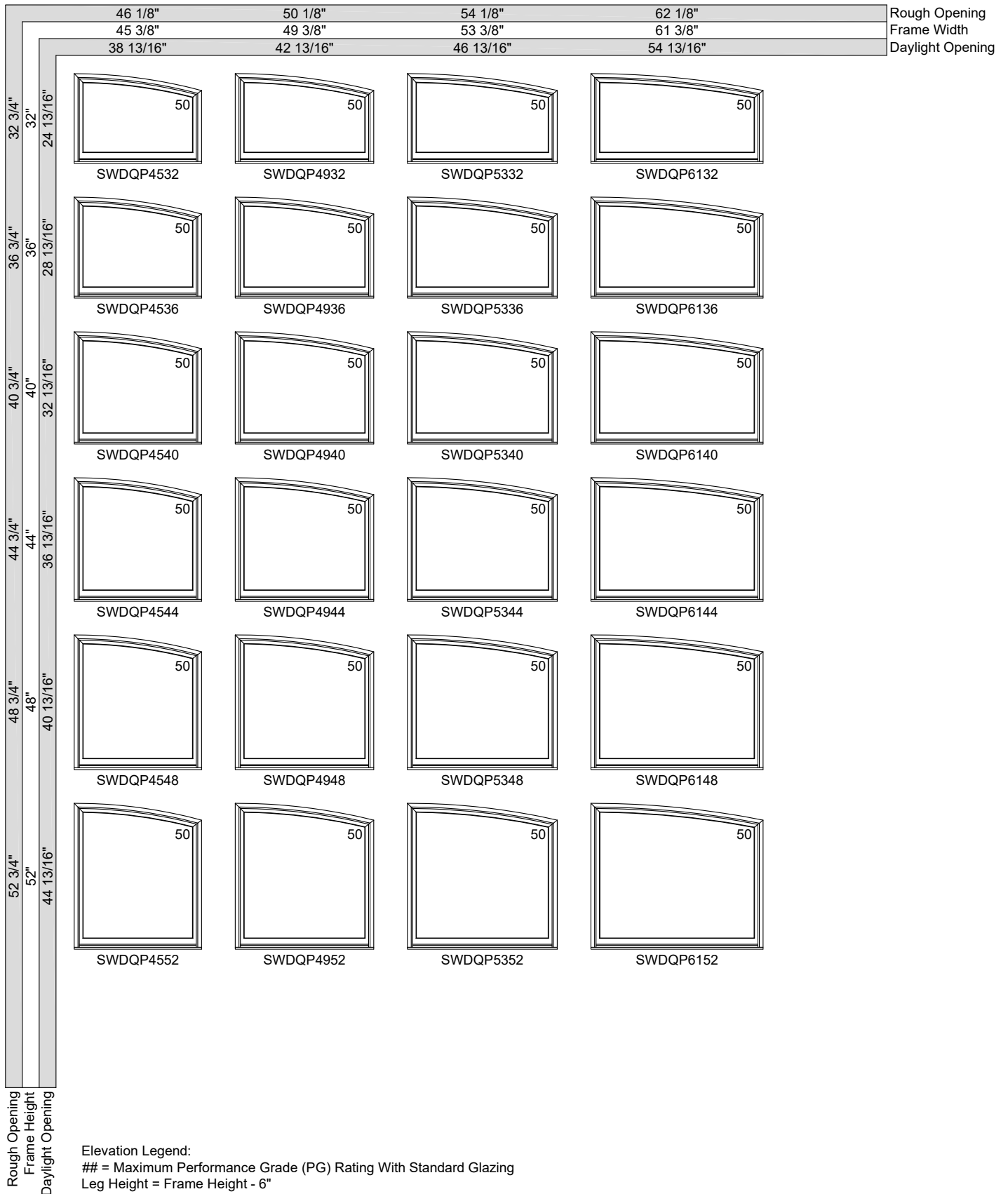

FIXED UNITS - EXTENDED QUARTER SEGMENT

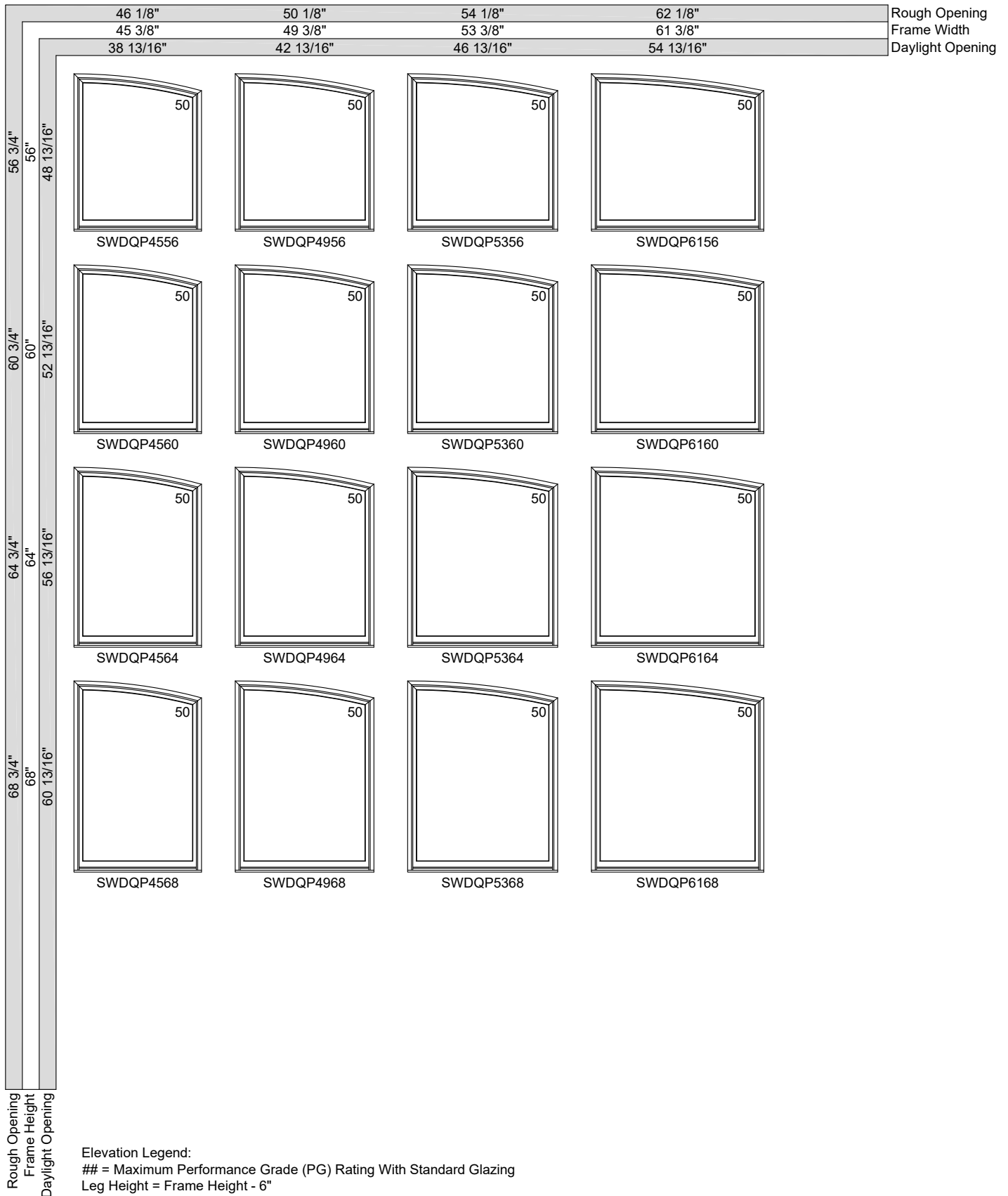

FIXED UNITS - EXTENDED QUARTER SEGMENT

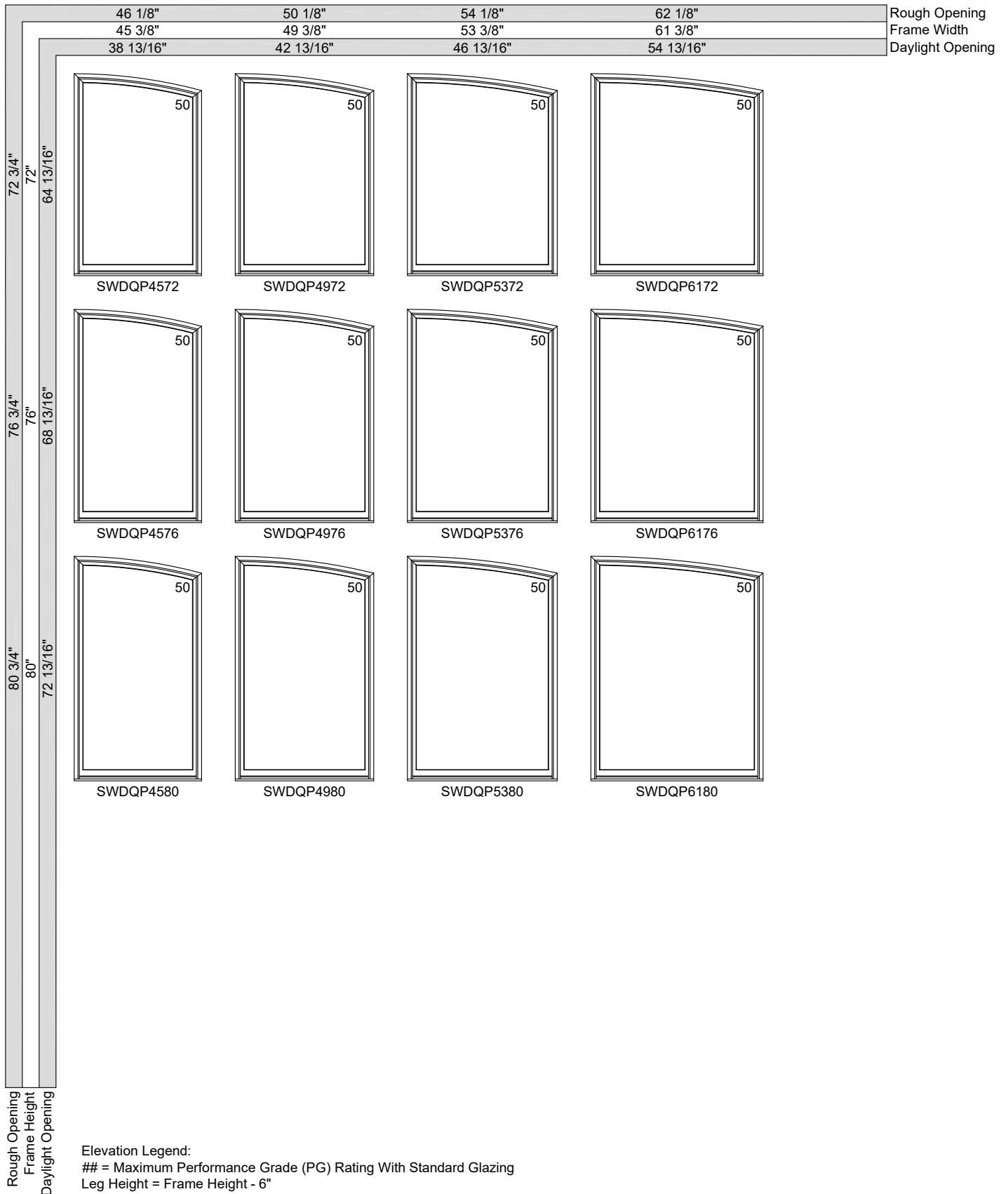

FIXED UNITS - EXTENDED QUARTER SEGMENT

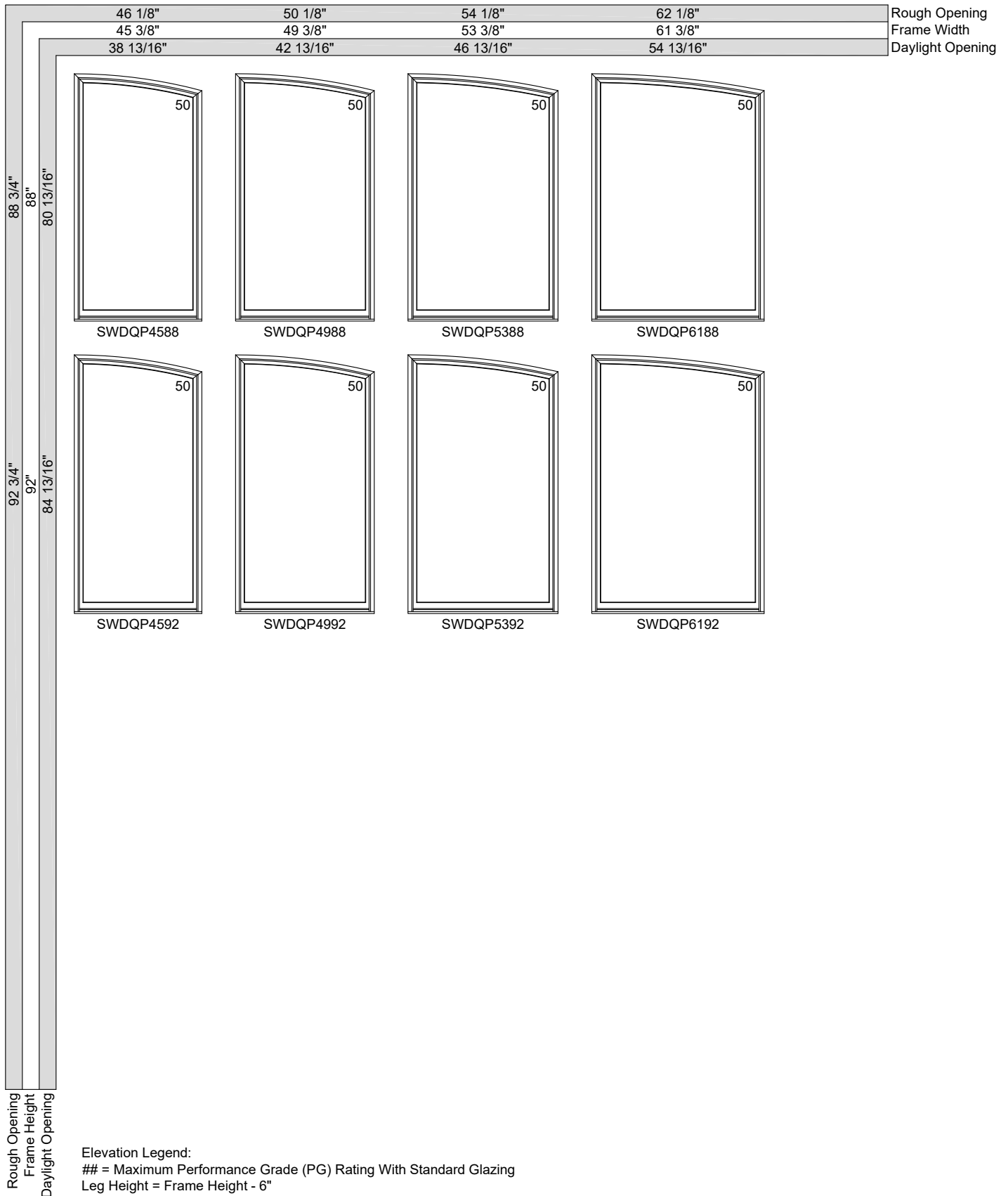

FIXED UNITS - EXTENDED QUARTER SEGMENT

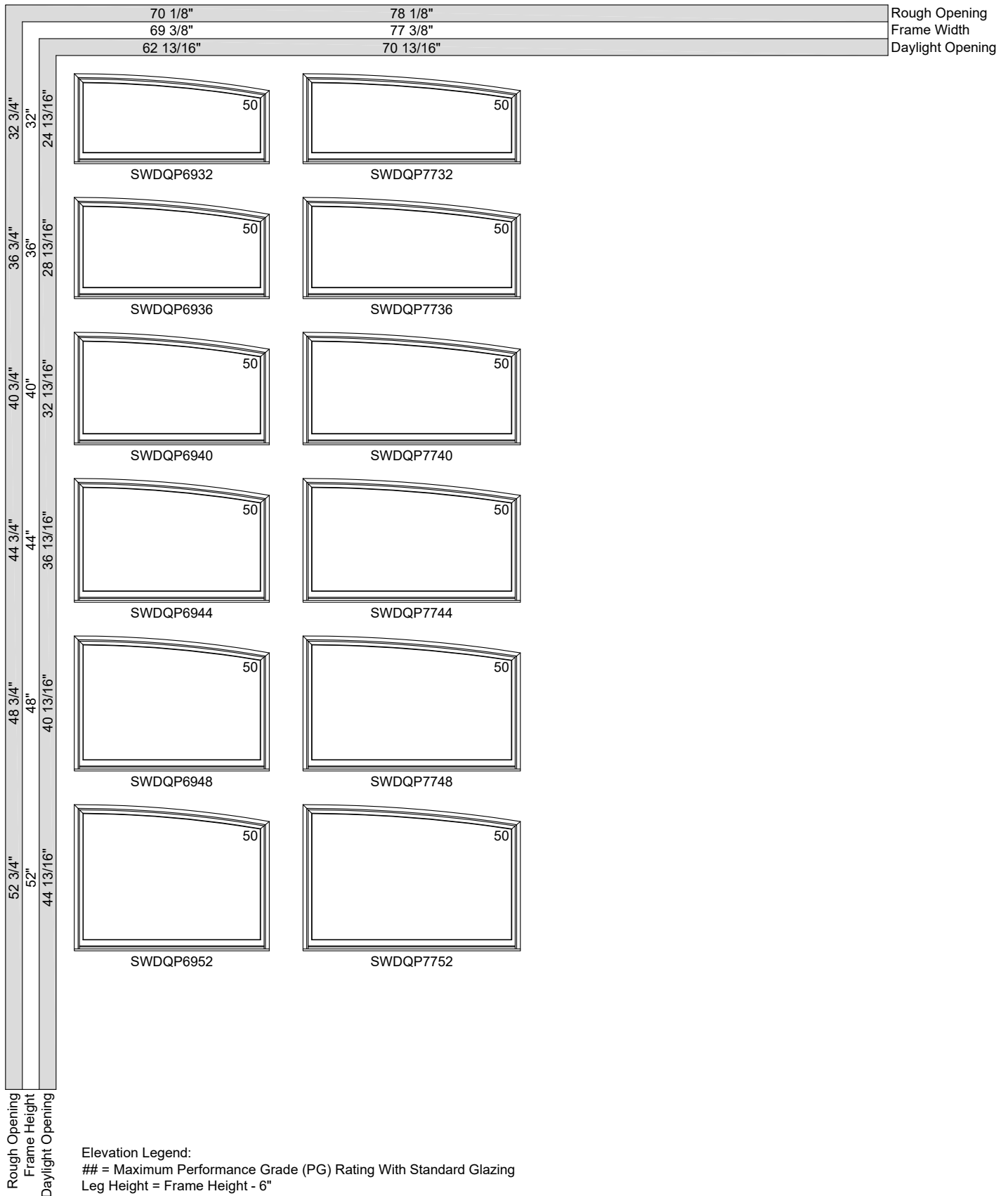

FIXED UNITS - EXTENDED QUARTER SEGMENT

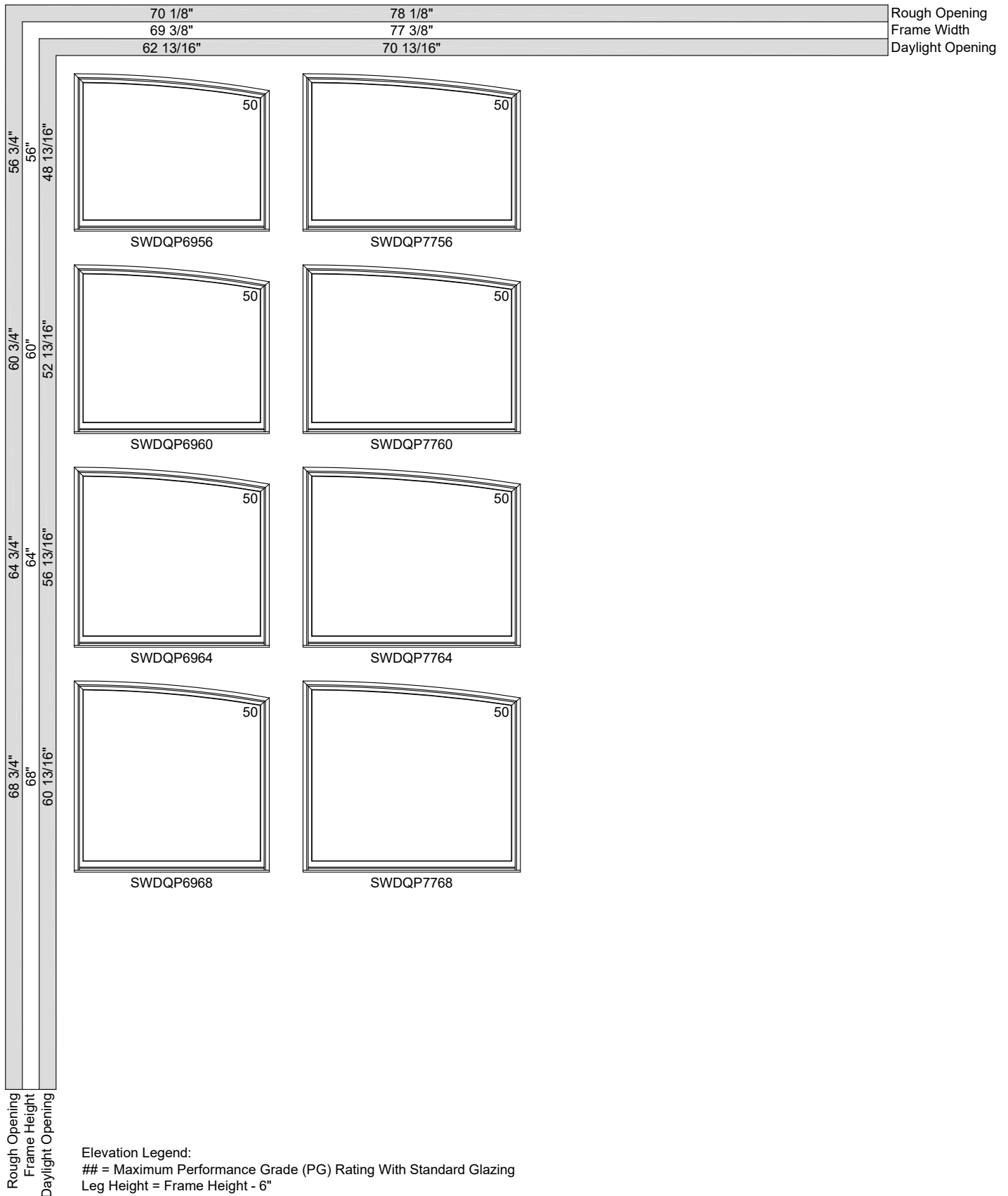

FIXED UNITS - EXTENDED QUARTER SEGMENT

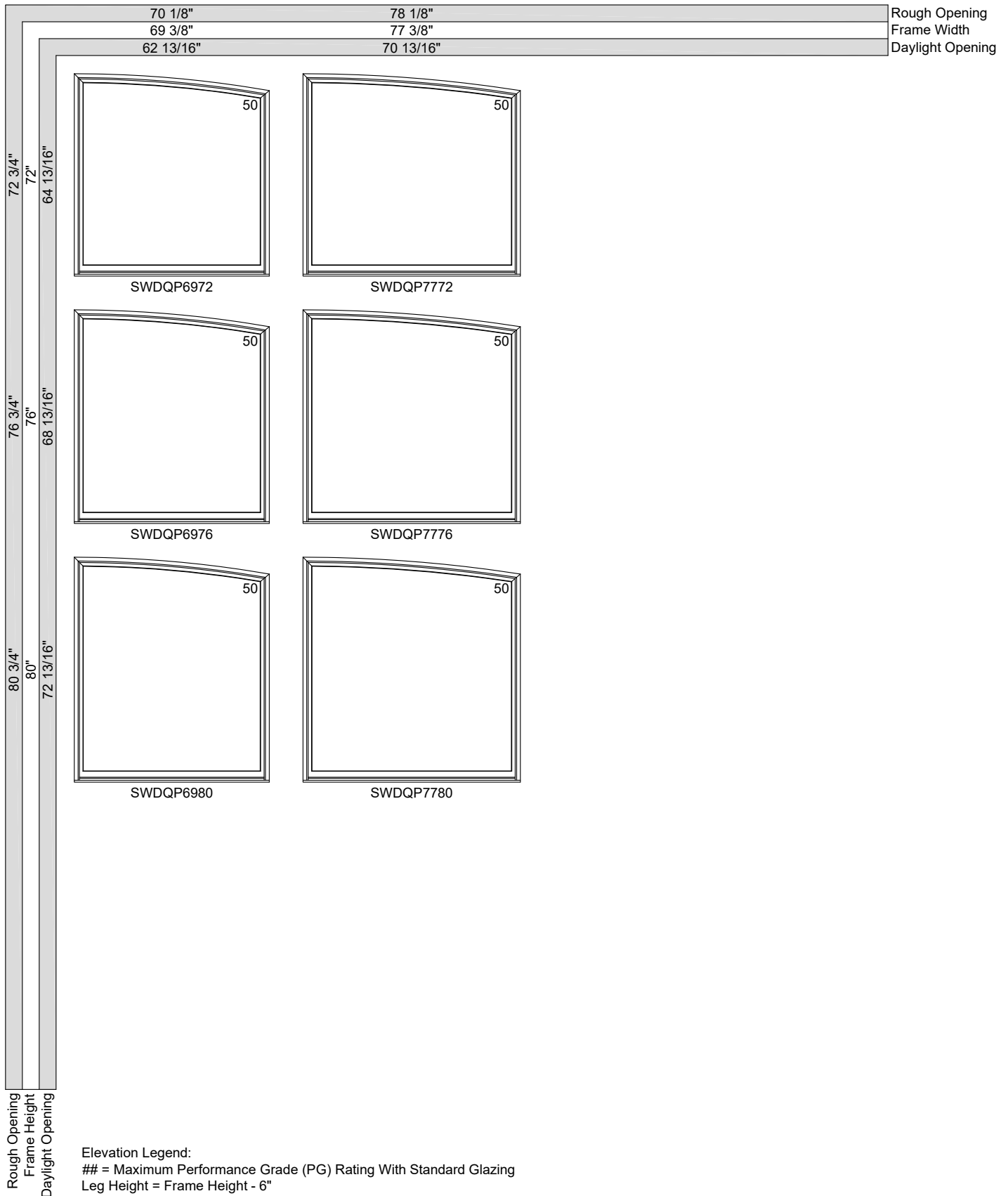

FIXED UNITS - EXTENDED QUARTER SEGMENT

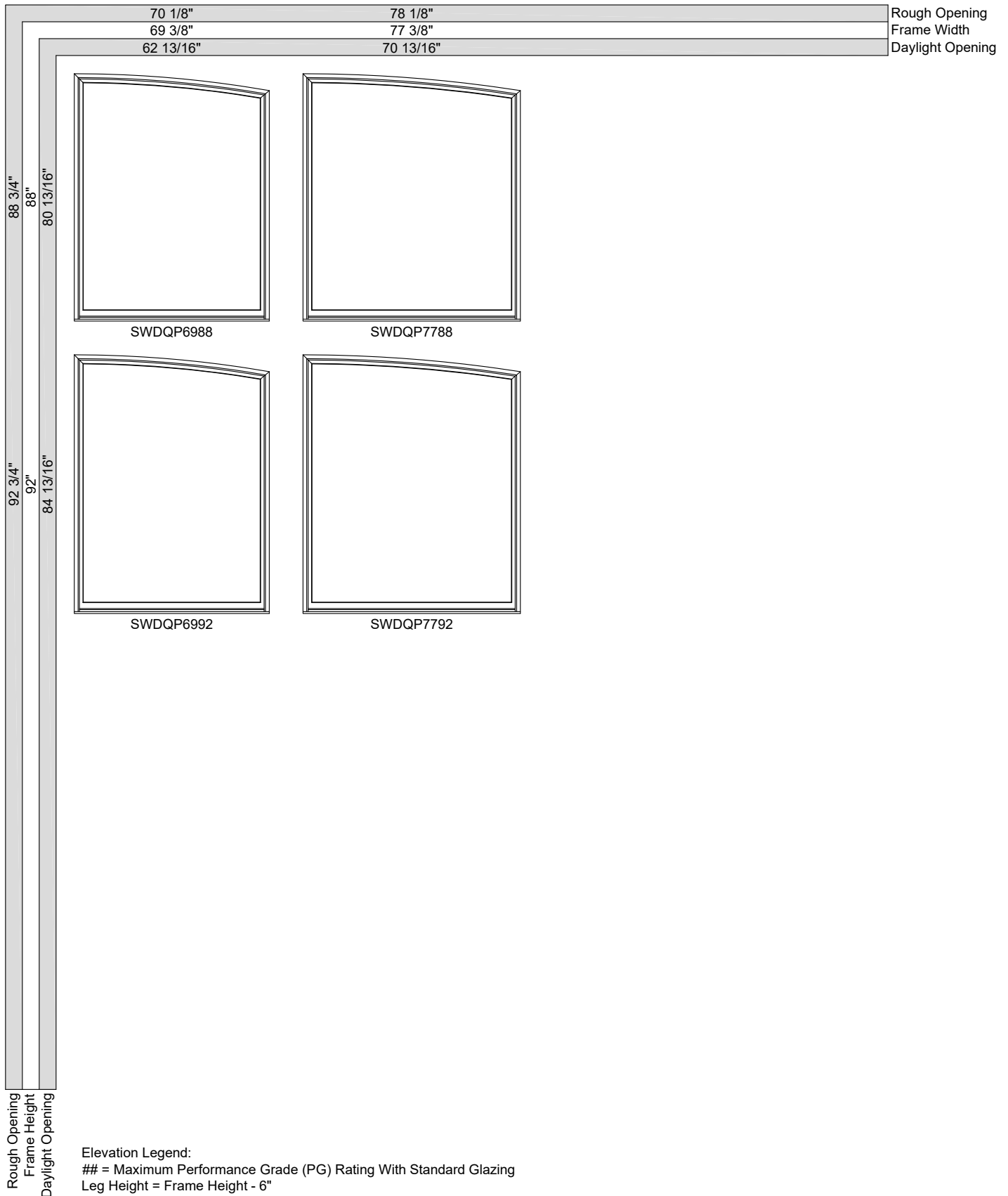

FIXED UNITS - EXTENDED HALF ROUND

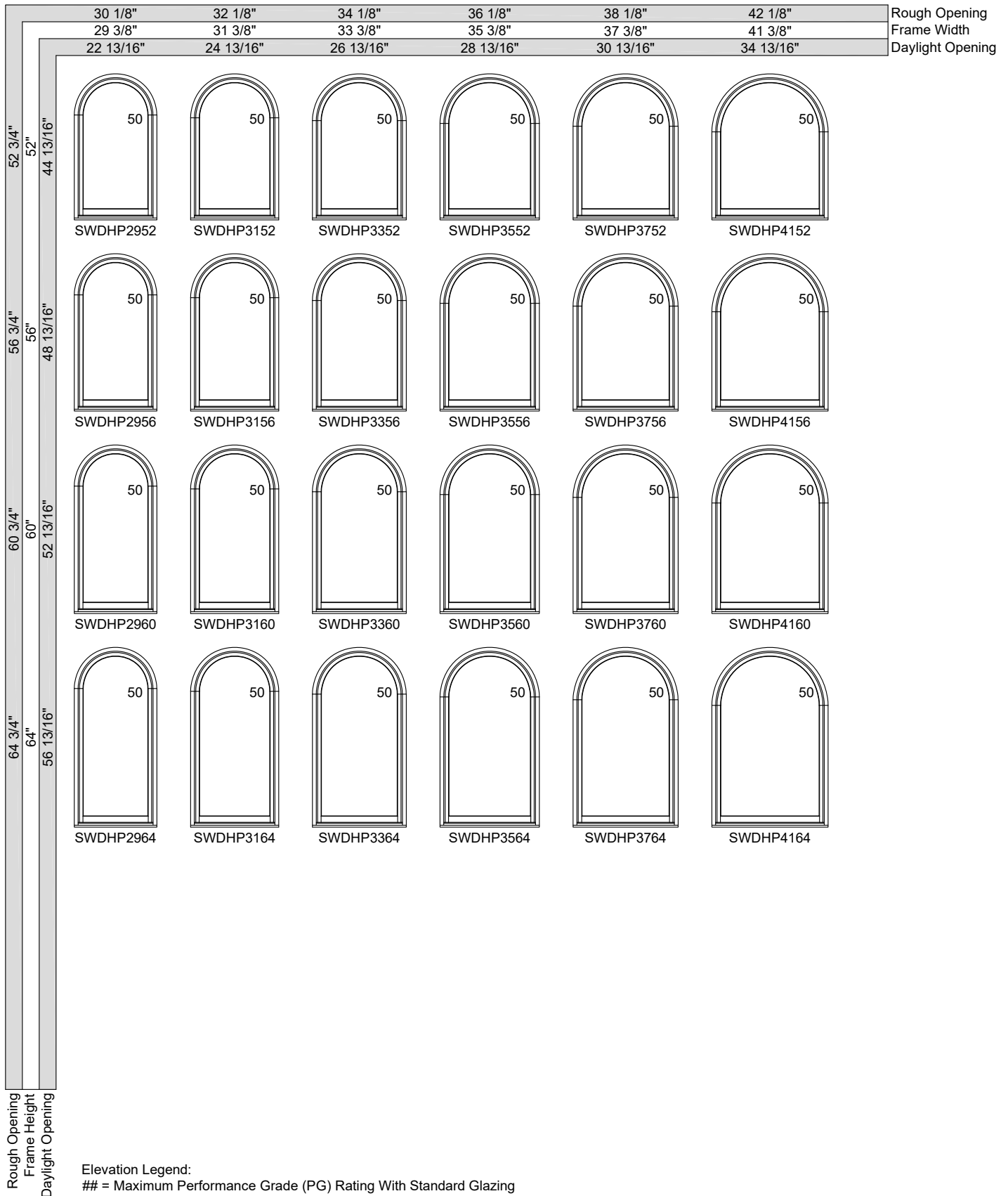

FIXED UNITS - EXTENDED HALF ROUND

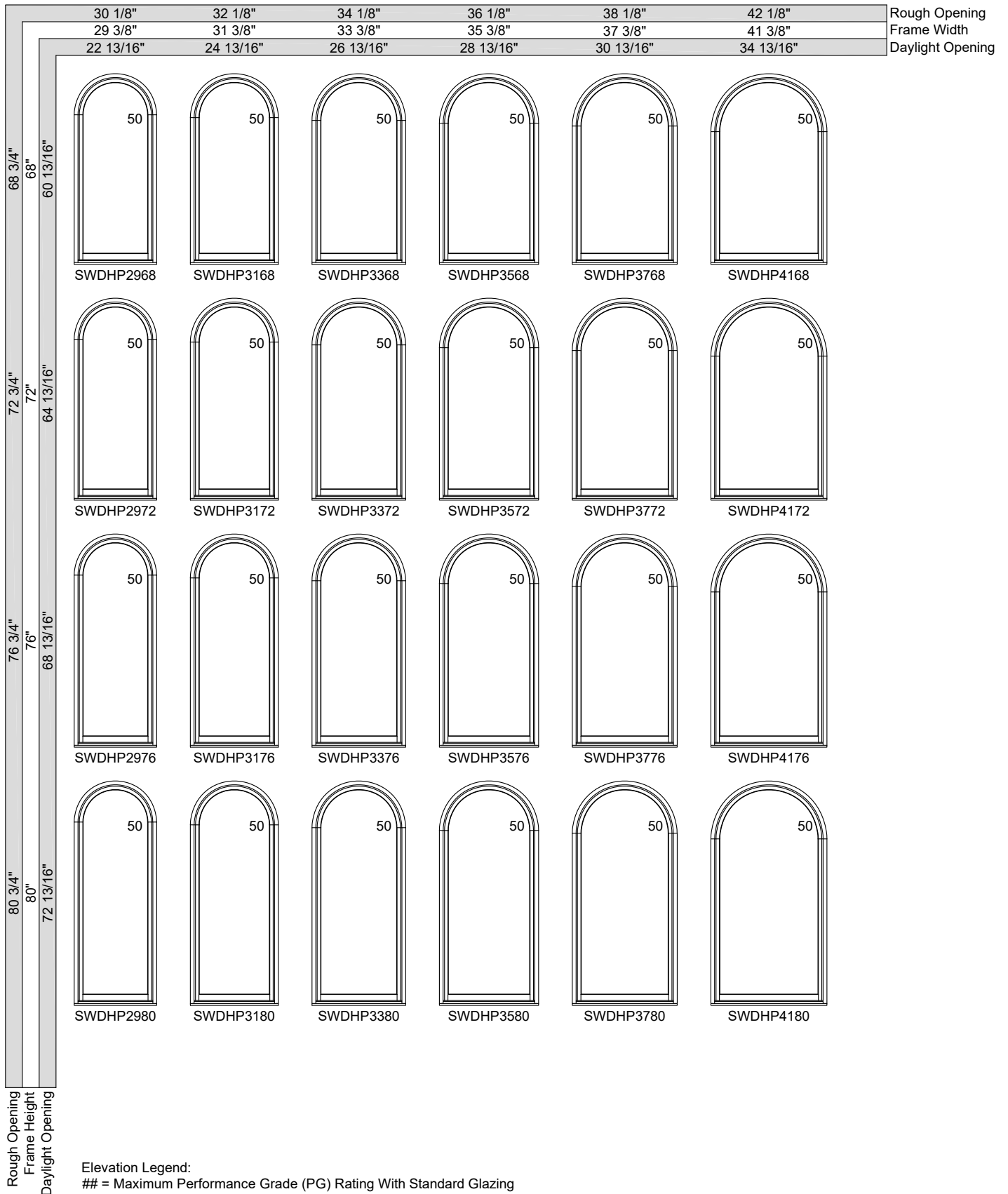

FIXED UNITS - EXTENDED HALF ROUND

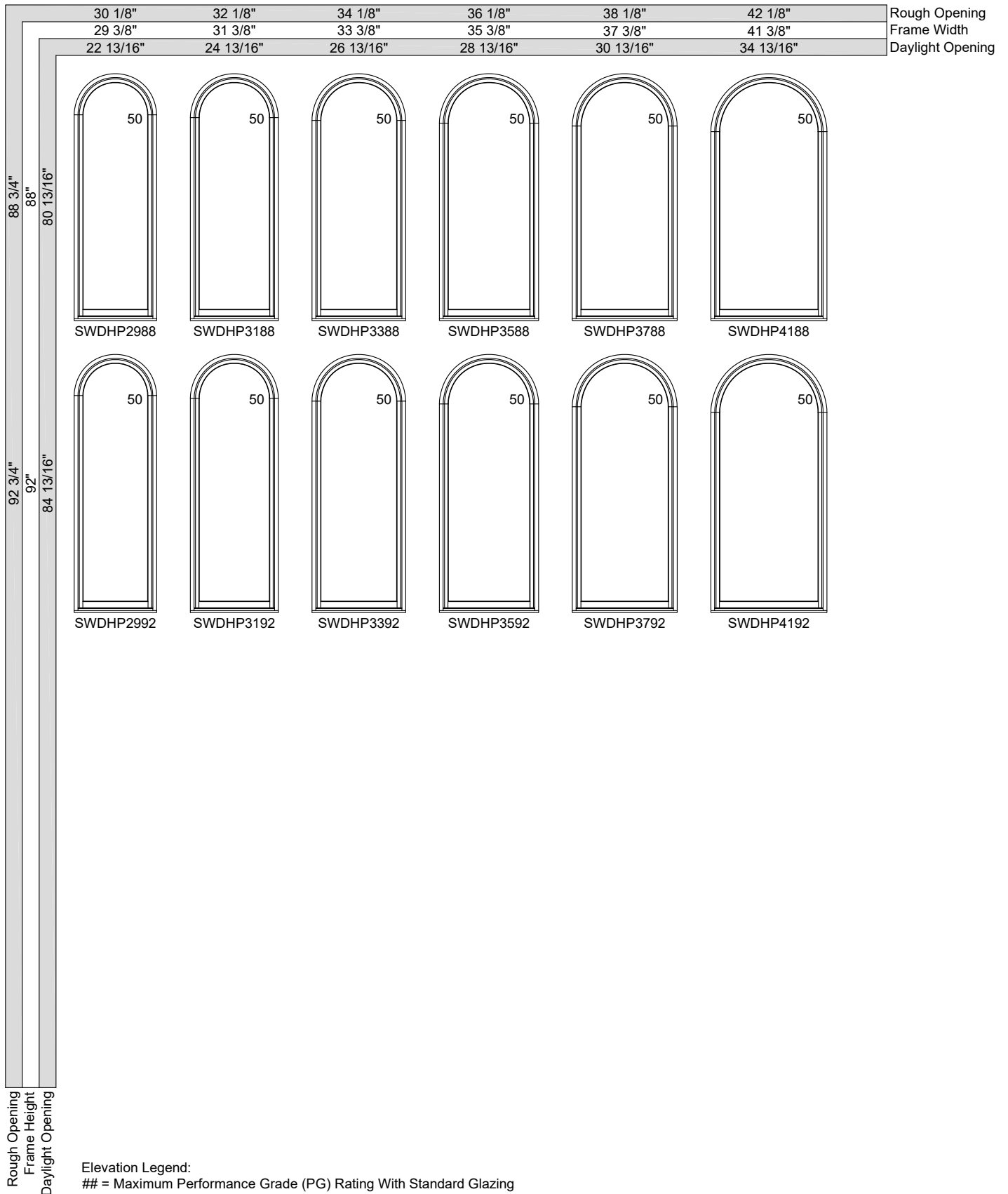

FIXED UNITS - EXTENDED HALF ROUND

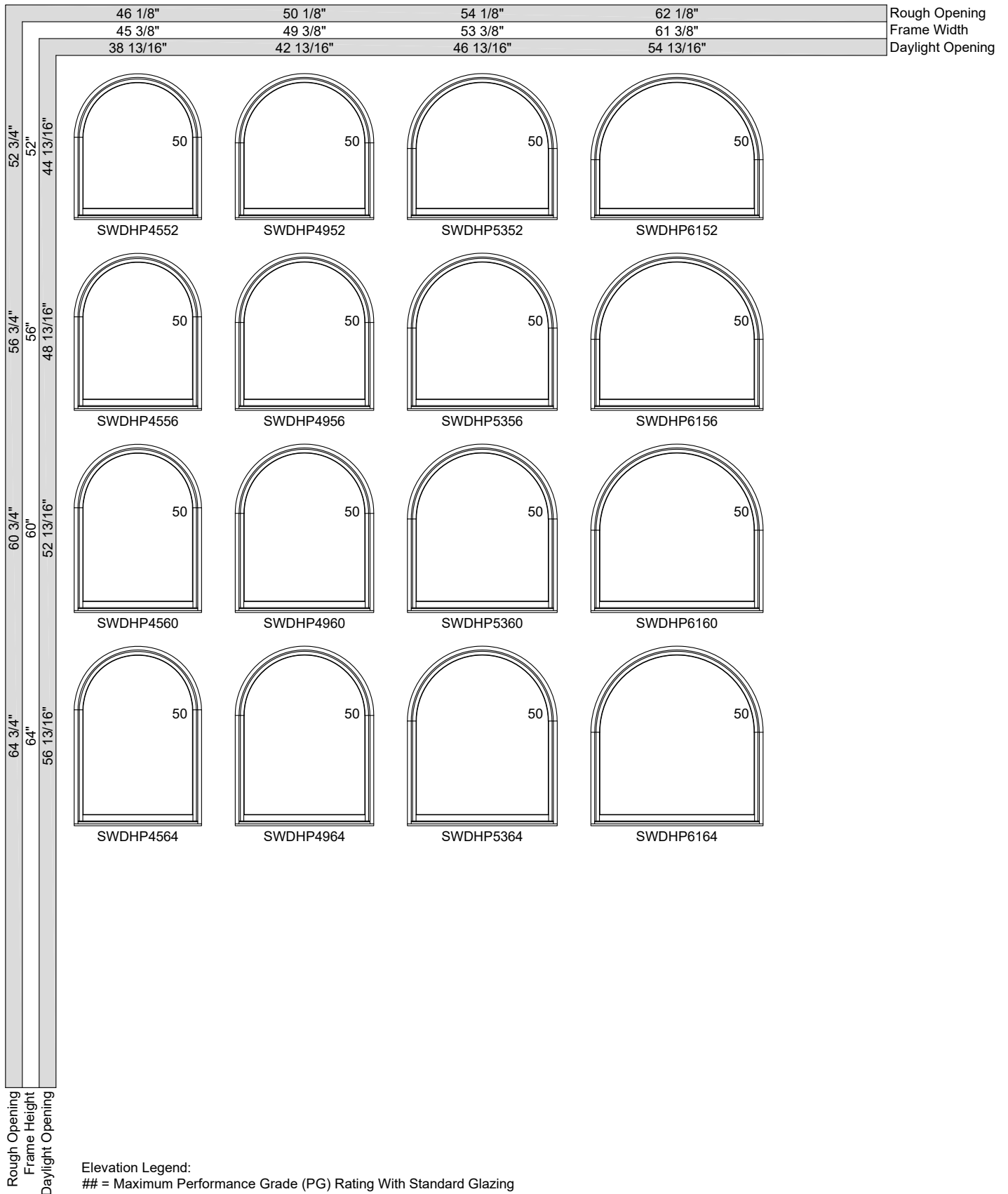

FIXED UNITS - EXTENDED HALF ROUND

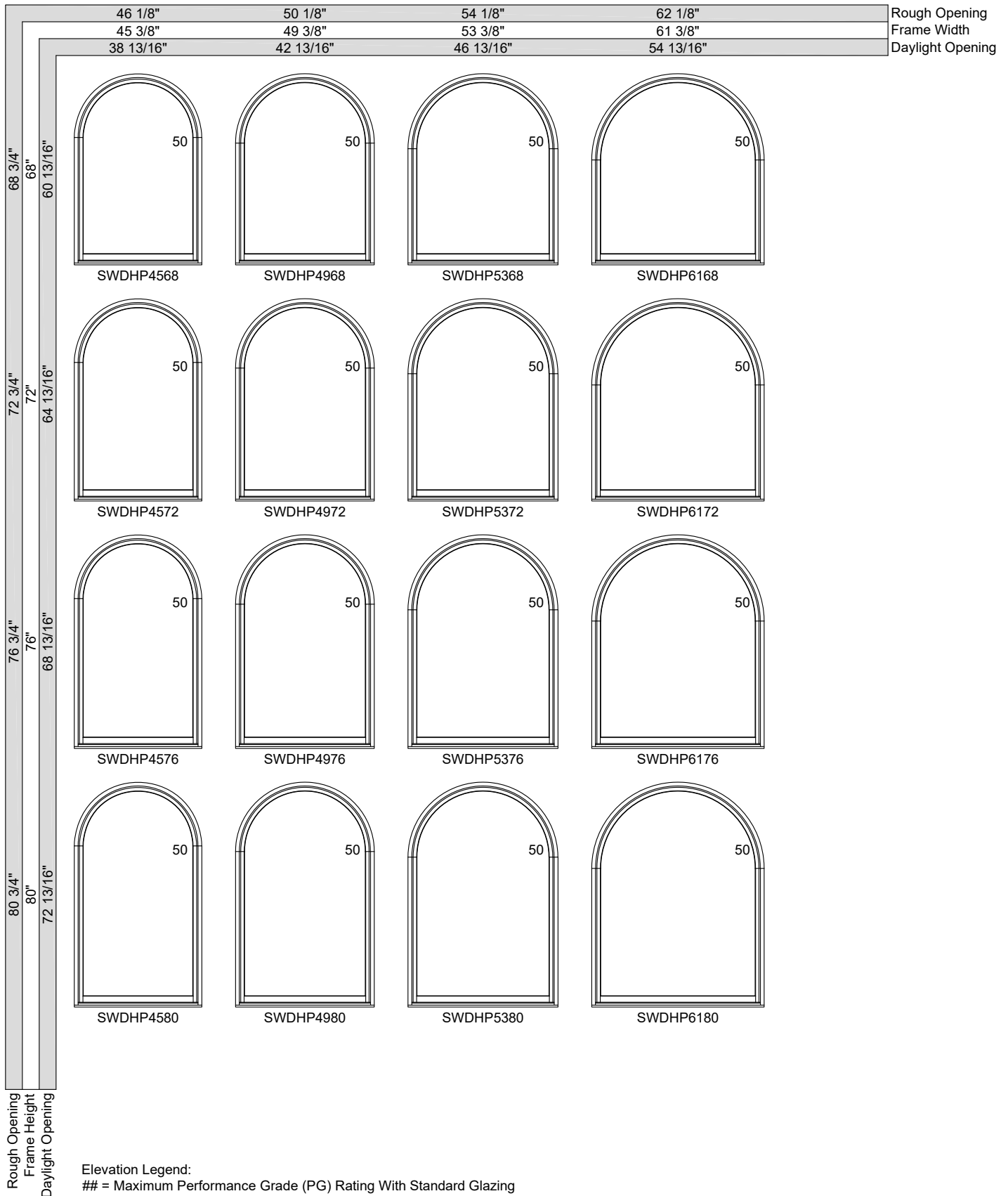

FIXED UNITS - EXTENDED HALF ROUND

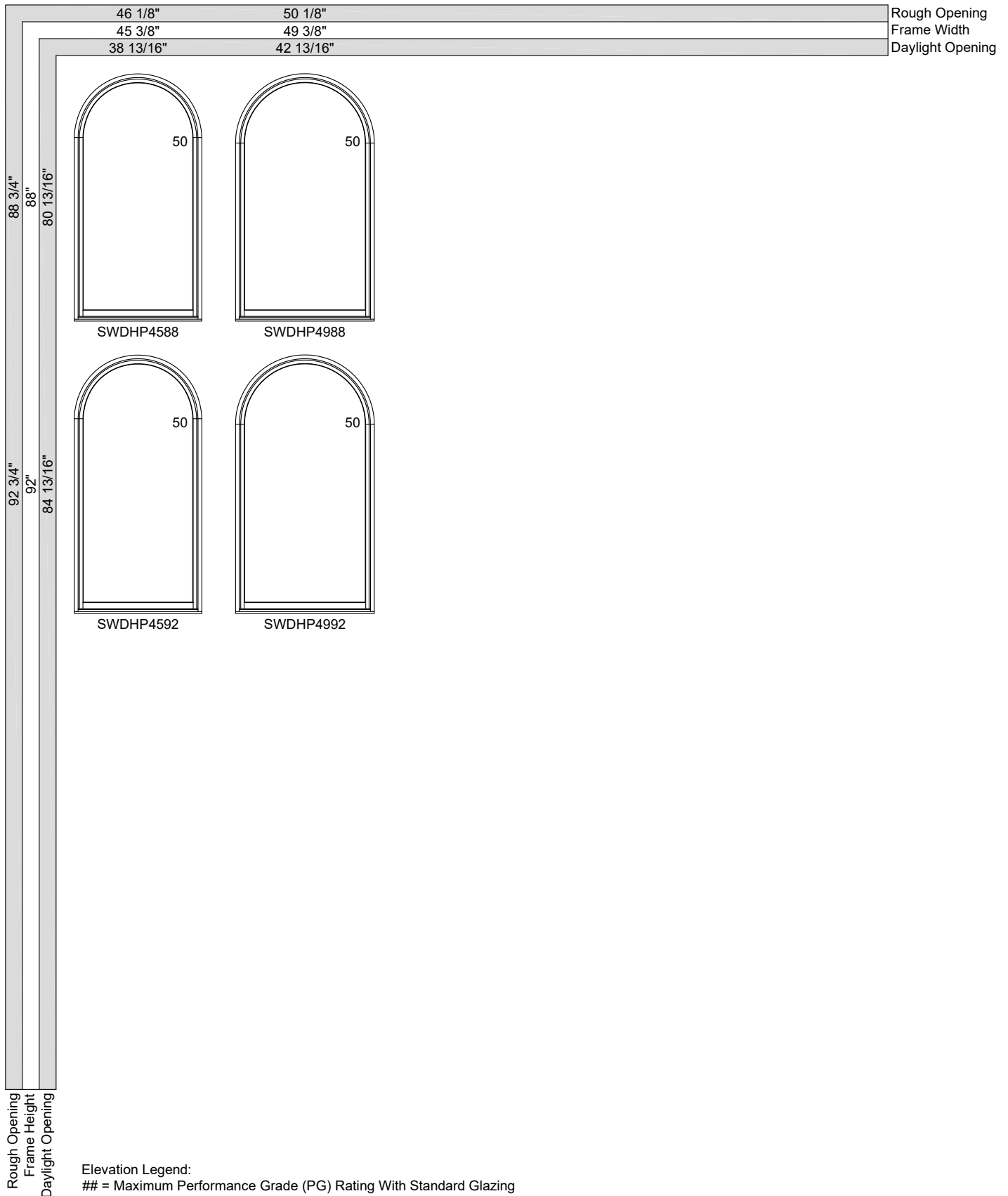

FIXED UNITS - EXTENDED HALF ROUND

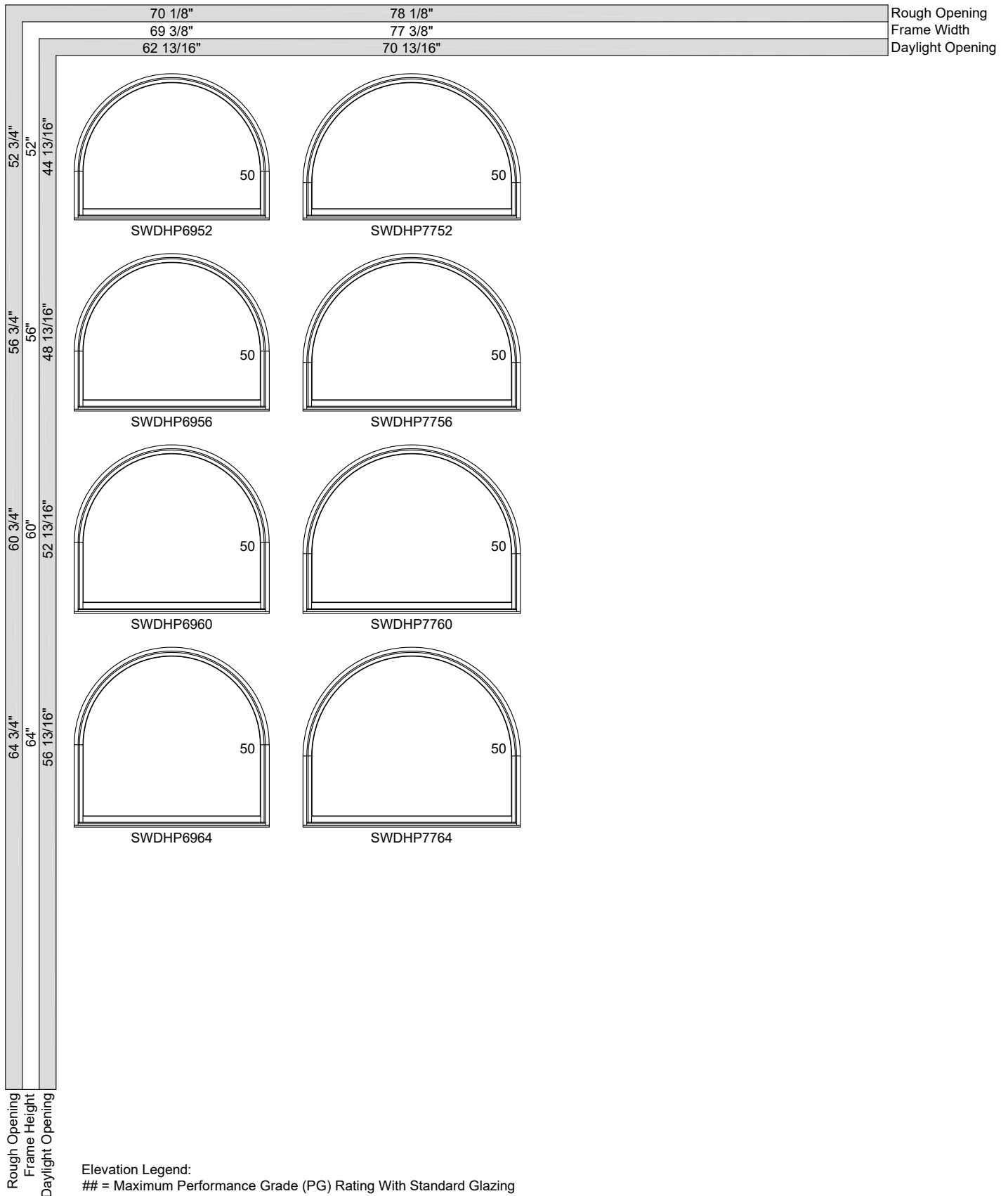

FIXED UNITS - EXTENDED HALF ROUND

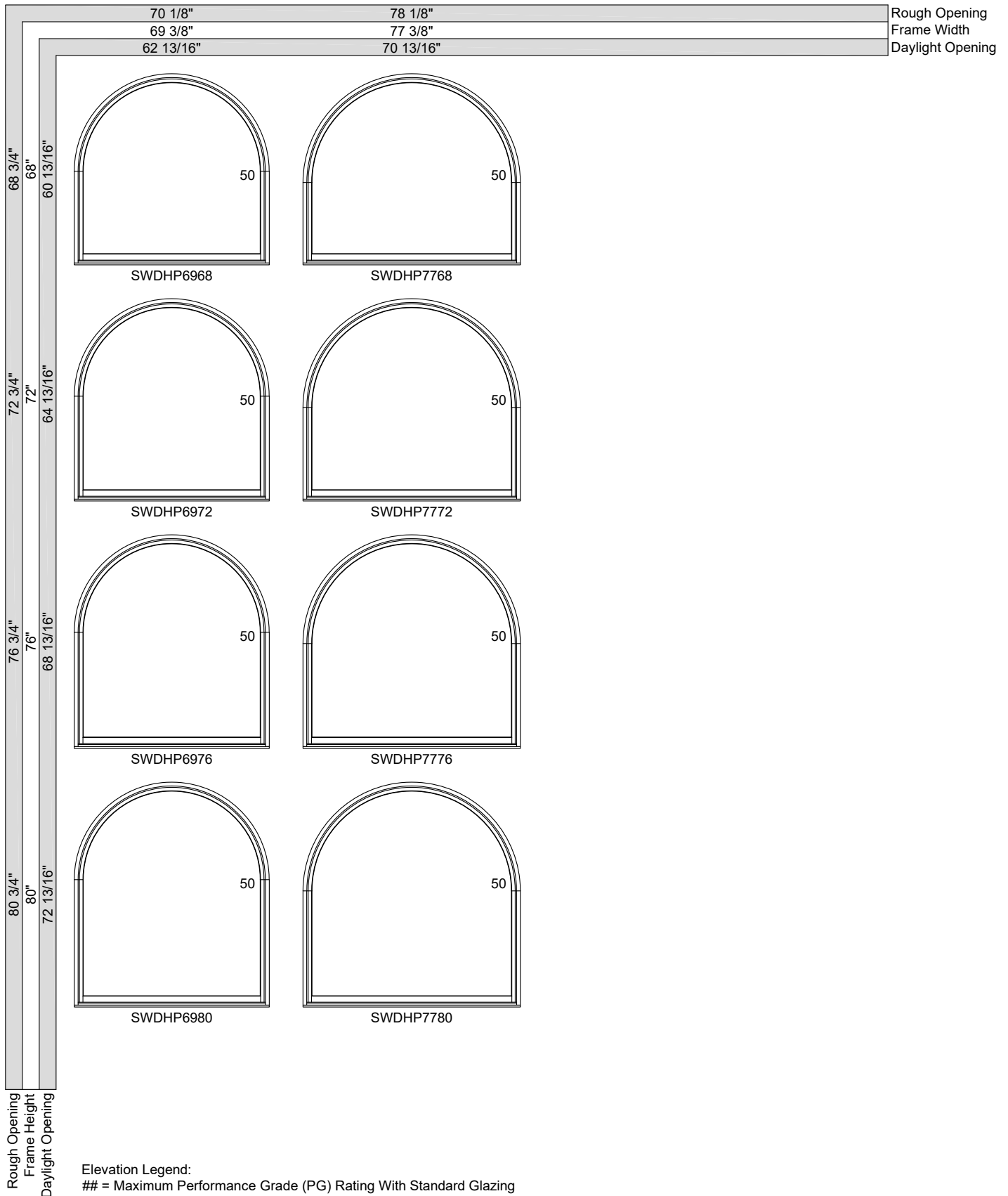



WATERBARRIER® BEST DURABILITY



F37662LEW

Low-E
7/8" SDL Bar
1-7/16" Double Hip
Raised Panel
Wide Layout
Ovolo Sticking

3/0 x 6/8



F37663LEW

Low-E
7/8" SDL Bar
1-7/16" Double Hip
Raised Panel
Ovolo Sticking

1/0 x 6/8
1/2 x 6/8



F37508LEW

Low-E
7/8" SDL Bar
1-7/16" Double Hip
Raised Panel
Wide Layout
Ovolo Sticking

2/6 x 6/8 2/6 x 7/0
2/8 x 6/8 2/8 x 7/0
3/0 x 6/8 3/0 x 7/0



F37982LEW

Low-E
7/8" SDL Bar
1-7/16" Double Hip
Raised Panel
Wide Layout
Ovolo Sticking

2/8 x 6/8 2/8 x 7/0
3/0 x 6/8 3/0 x 7/0

Douglas Fir

SASH DOORS 7/8" SDL BAR & 1-7/16" DOUBLE HIP RAISED PANEL



WaterBarrier® 7/8" SDL Bar, 1-7/16" Double Hip Raised Panel with Low-E Glass - Exterior Side



WaterBarrier® Door Corner

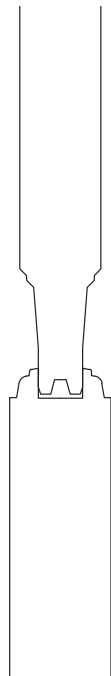

Panel Profile

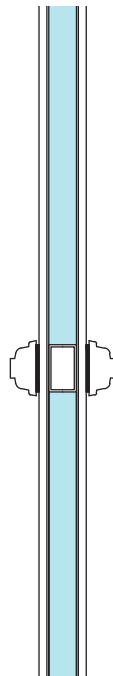

Glass Profile



1-7/16" Double Hip Raised Panel - Interior Side



SITELINE® | SLIDING PATIO DOOR

WOOD PATIO DOORS

ARCHITECTURAL DESIGN MANUAL | May 2024

TABLE OF CONTENTS

PRODUCT INFORMATION

GENERAL INFORMATION	3
CLEAR OPENING LAYOUT	4
GRID PATTERNS	5
GRID OPTIONS	6
UNIT SIZING	7
TRIM OPTIONS	8
JAMB EXTENDER OPTIONS	9
MULLION OPTIONS	10

SECTION DETAILS

NARROW STILE OPERATOR SECTIONS	11
NARROW STILE 4 PANEL OPERATOR - HORIZONTAL SECTIONS	12
NARROW STILE STATIONARY SECTIONS	13
WIDE STILE OPERATOR SECTIONS	14
WIDE STILE 4 PANEL OPERATOR - HORIZONTAL SECTIONS	15
WIDE STILE STATIONARY SECTIONS	16
NARROW STILE TRANSOM SECTIONS	17
WIDE STILE TRANSOM SECTIONS	18

SIZING DETAILS

FORMULAS	19
MIN-MAX STANDARD SIZING	20
1 PANEL WIDE STILE UNITS	23
2 PANEL WIDE STILE UNITS	24
4 PANEL WIDE STILE UNITS	25
TRANSOM WIDE STILE UNITS	27
1 PANEL WIDE STILE UNITS	28
2 PANEL WIDE STILE UNITS	29
4 PANEL WIDE STILE UNITS	30
TRANSOM WIDE STILE UNITS	32

GENERAL INFORMATION

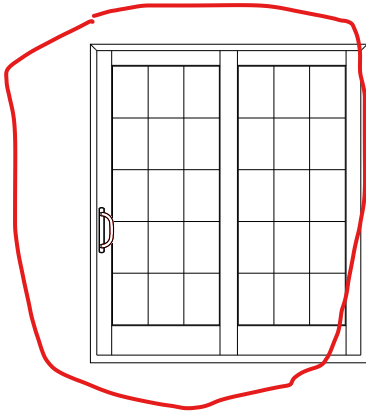

Dimensional Doors

Siteline® Wood Sliding Patio Doors may be specified as "dimensional" by adjusting the desired rough opening width or height in 1/4" increments from standard.

Siteline® Wood Sliding Patio Doors are available in single, twin, and quad panel doors. The standard size range includes sizes specifically designed for replacement of older patio door models in existing structures, as well as a full range of "true size" products for architectural consistency.

Operation

Siteline® Wood Sliding Patio Doors are available in a full range of operating and stationary styles. Single panel doors are only available as stationary (non-venting) styles. Two-panel doors are available with left or right operation. Four-panel doors are available with two panels operating from the center. Configuration and handing is based on viewing the door from the exterior.

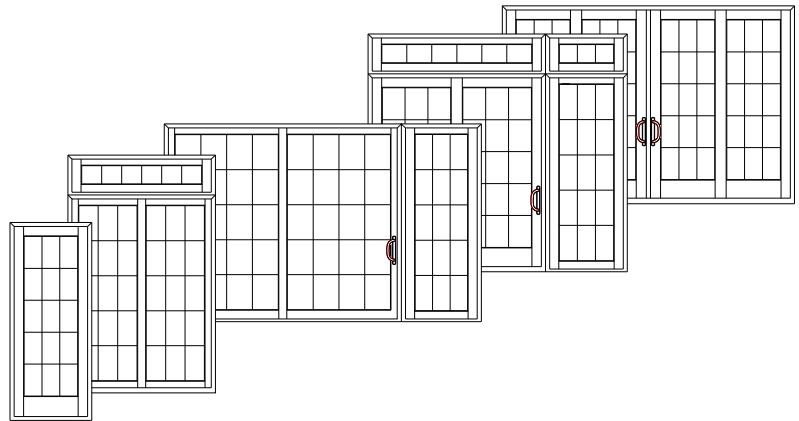

Multiple Assemblies

Siteline® Wood Sliding Patio Doors are available in a wide variety of multiple panel configurations from the factory, all of which are assembled with continuous sills. Mulling to like products in the field is not recommended. Instead, individual factory assembled units should be installed in contiguous rough openings, in order to provide adequate framing support to assure the best performance of the door systems.

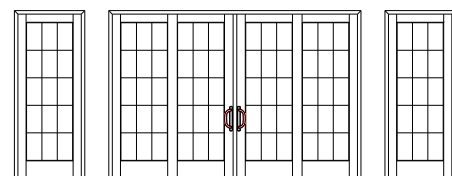
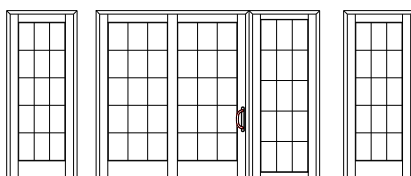
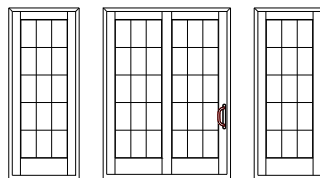

CLEAR OPENING LAYOUT

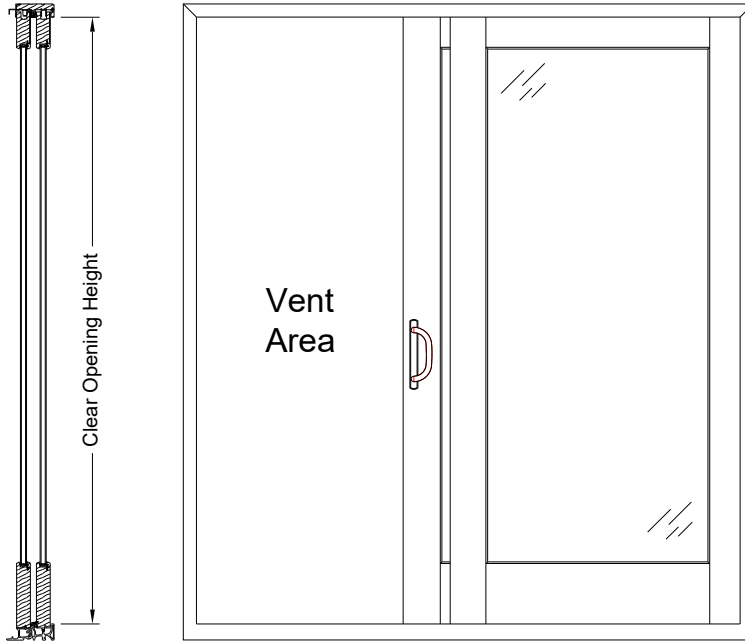

Panel Callout	Narrow Stile	Wide Stile
2-6	30 1/8"	30 13/16"
3-0	36 1/8"	36 13/16"
4-0	48 1/8"	48 13/16"

Vertical Clear Opening = Frame Height - 3 21/32"

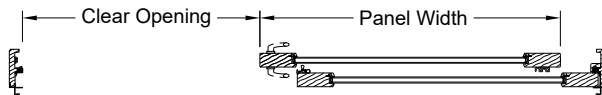

Horizontal 2-Panel Narrow Stile

With Bumper = (Frame Width/2) - 7 5/8"

Without Bumper = (Frame Width/2) - 6 3/8"

Horizontal 2-Panel Wide Stile

With Bumper = (Frame Width/2) - 8 5/16"

Without Bumper = (Frame Width/2) - 7 1/16"

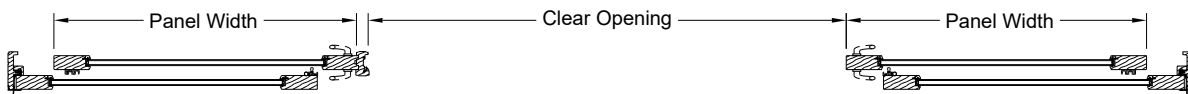

Horizontal 4-Panel Wide Stile Both Panels Open

With Bumper = (Frame Width/2) - 15 1/8"

Without Bumper = (Frame Width/2) - 12 5/8"

Horizontal 4-Panel Narrow Stile Both Panels Open

With Bumper = (Frame Width/2) - 13 3/4"

Without Bumper = (Frame Width/2) - 11 1/4"

Horizontal 4-Panel Wide Stile Active Panel Open

With Bumper = (Frame Width/4) - 7 23/32"

Without Bumper = (Frame Width/4) - 6 15/32"

Horizontal 4-Panel Narrow Stile Active Panel Open

With Bumper = (Frame Width/4) - 7 1/32"

Without Bumper = (Frame Width/4) - 5 25/32"

GRID PATTERNS

Siteline® Wood Sliding Patio Doors are available with Grilles Between Glass (GBG), or Simulated Divided Lites (SDL) in various widths and styles. The standard grid patterns are shown below.

Special grid cut patterns can include a wide variety of straight line and radius patterns. Non-standard patterns are subject to factory approval.

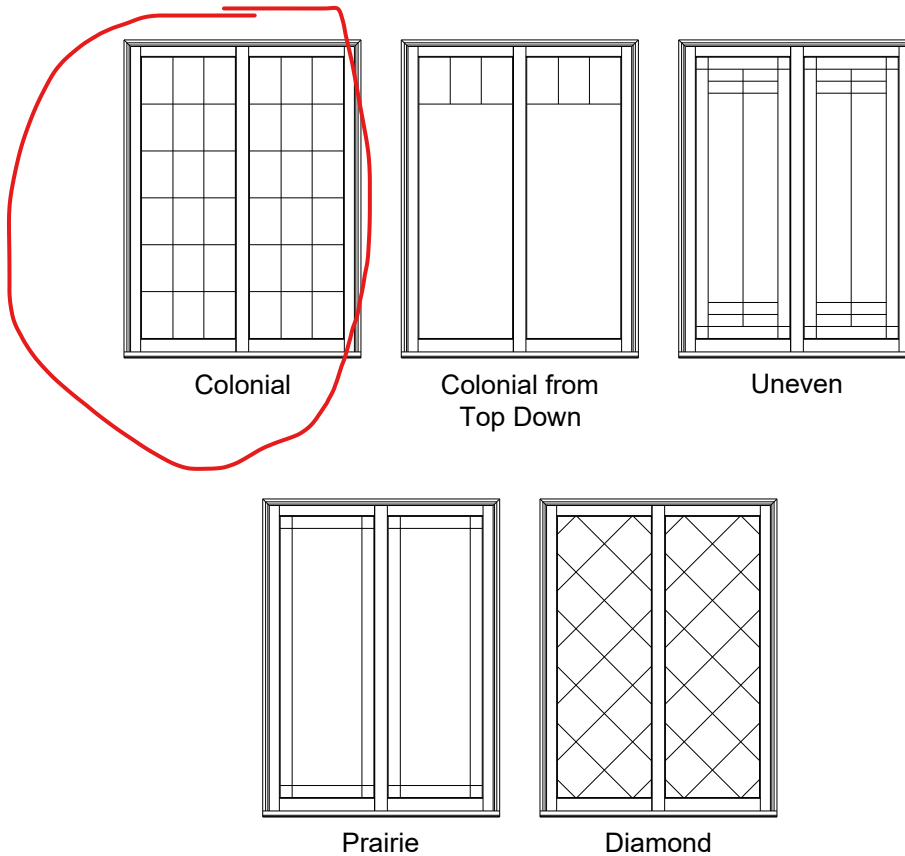

Bar Alignment

Alignment of bars from product to product is often required for fine architectural design. SDL, GBG, and wood grilles may be specified with bars aligned.

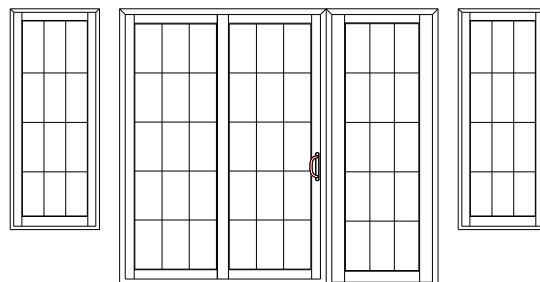

GRID OPTIONS

Exterior ← ————— → Interior

SDL Options

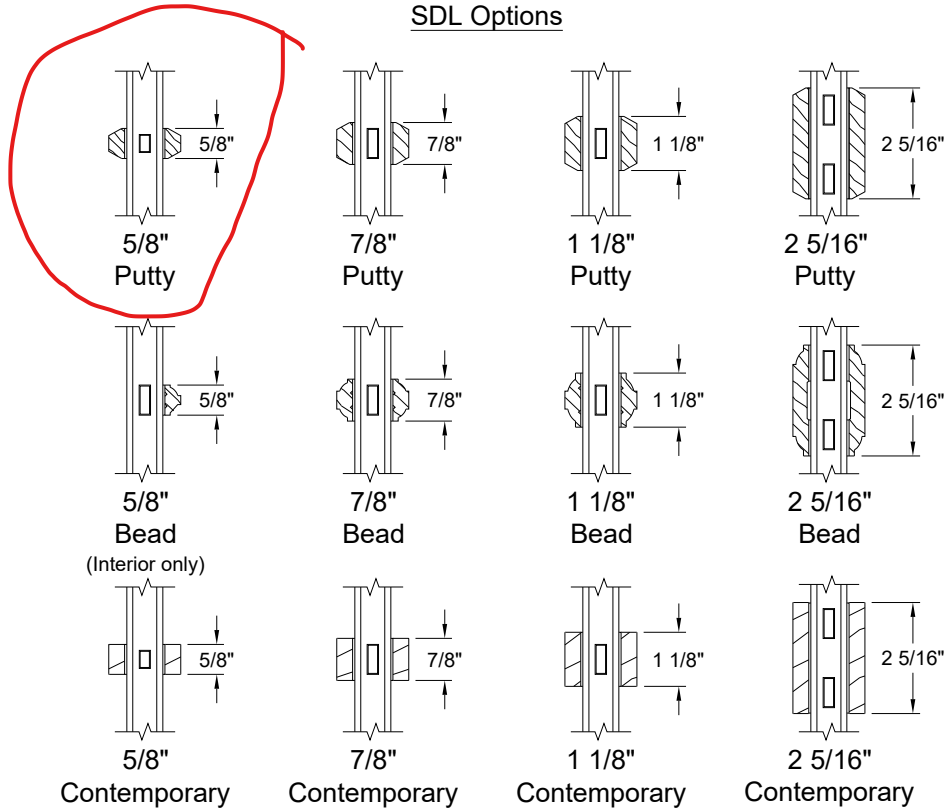

Note: Various Combinations of the SDL Bars Shown are Available

GBG Options

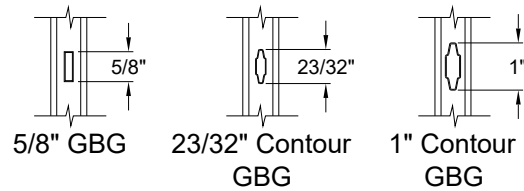

Bottom Rail & Glass Stop Options

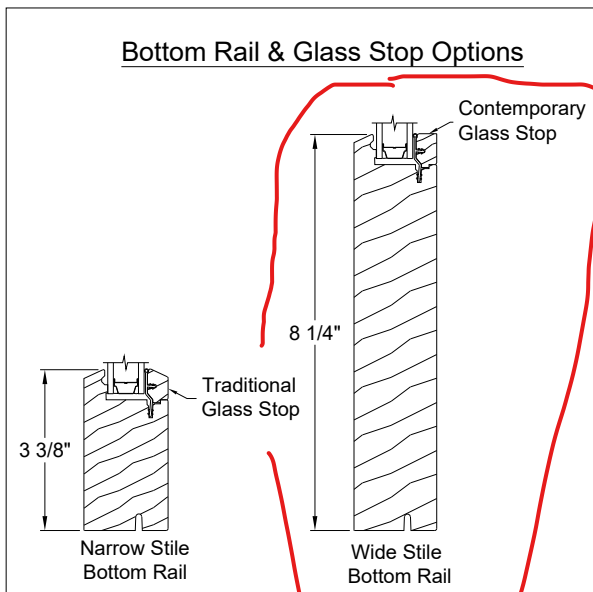

UNIT SIZING

Rough Opening

The frame size of the window plus 3/4".

Masonry Opening

The overall size of the window, including trim, plus 1/2".

Trim- 4 Sides Of Unit

When applied to 4 sides of unit, these dimensions apply to both vertical and horizontal window sections.

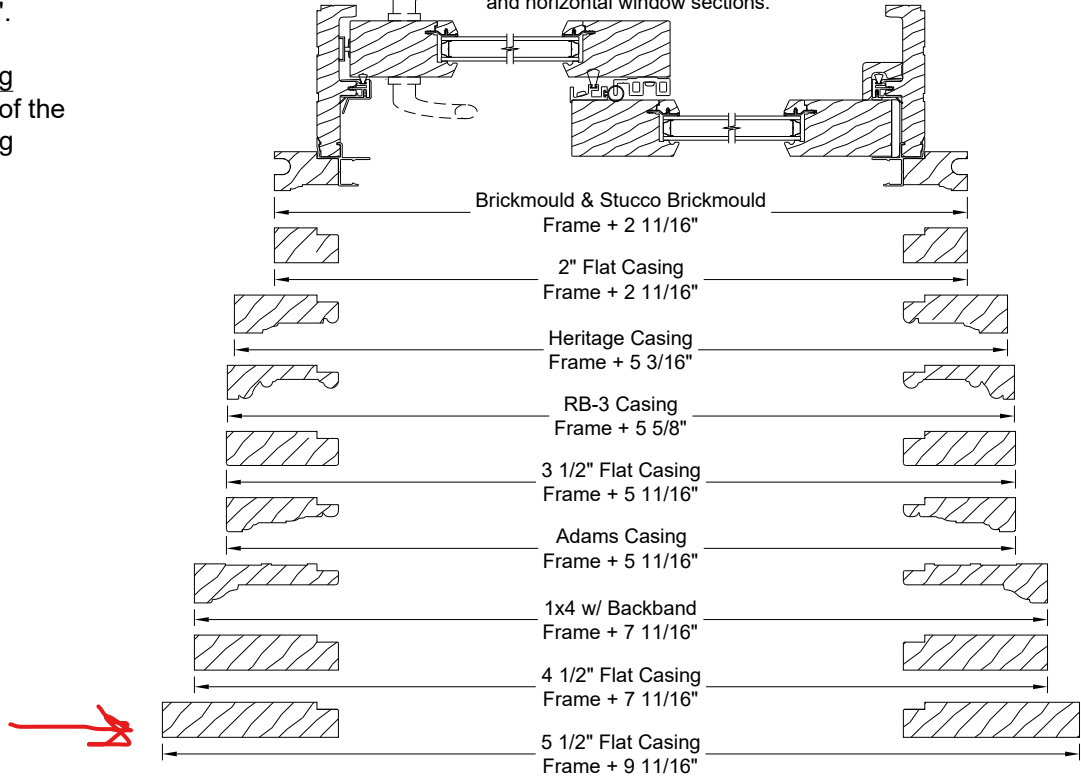

Trim- 3 Sides Of Unit

When applied to 3 sides of unit, with Standard Sill Nose, these dimensions apply to vertical window sections only.

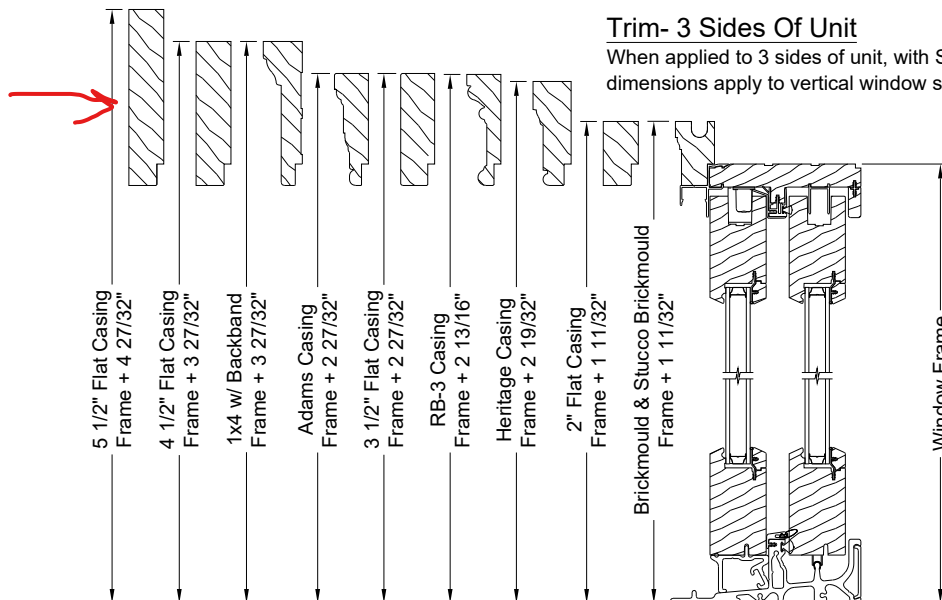

TRIM OPTIONS

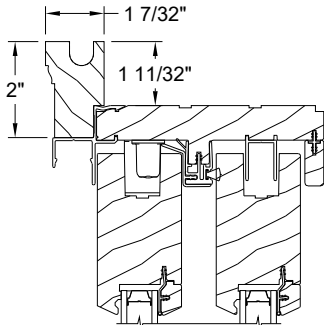

Brickmould &
Stucco Brickmould

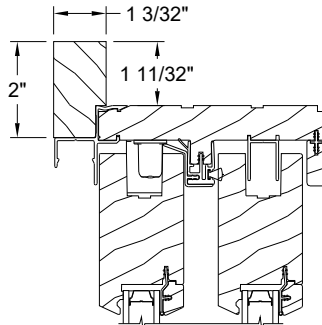

2" Flat Casing

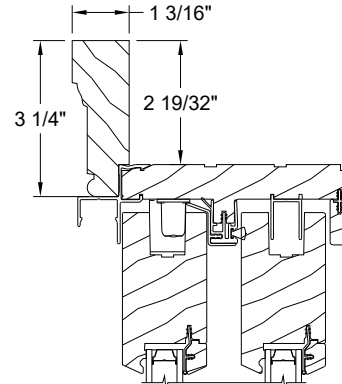

Heritage Casing

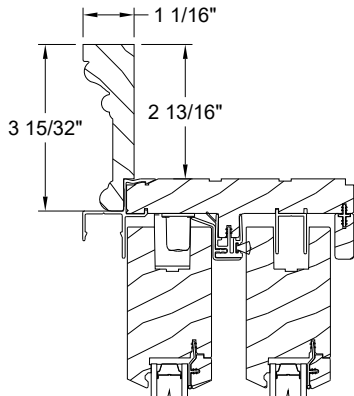

RB-3 Casing

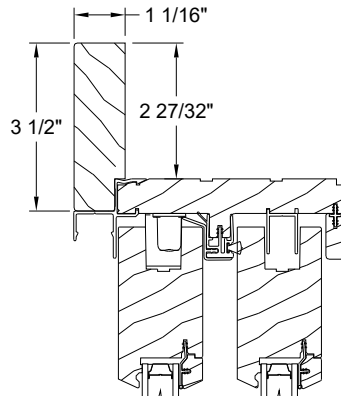

3 1/2" Flat Casing

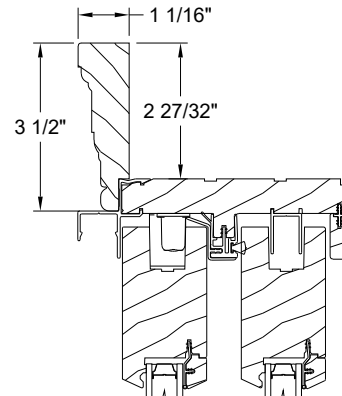

Adams Casing

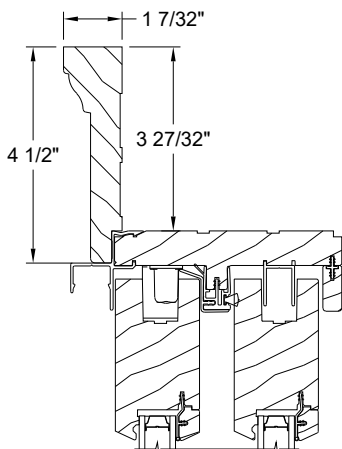

1x4 w/ Backband

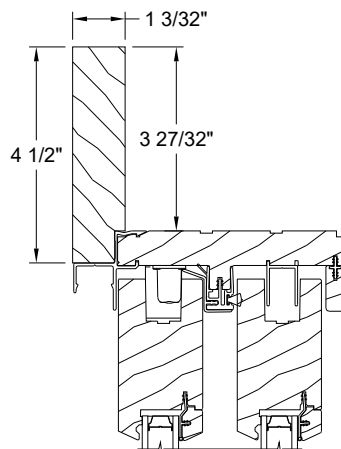

4 1/2" Flat Casing

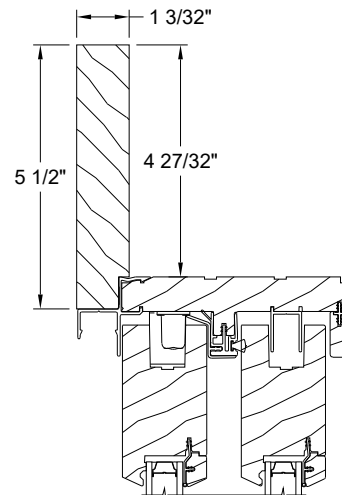

5 1/2" Flat Casing

JAMB EXTENDER OPTIONS

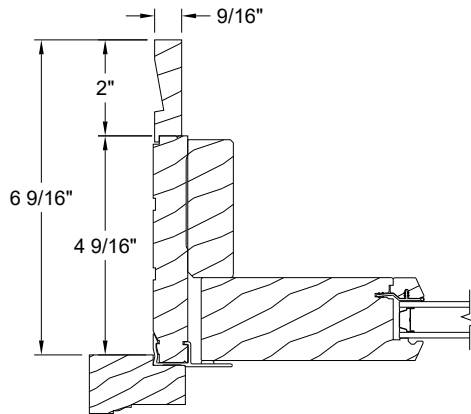

6 9/16" Jamb Extender

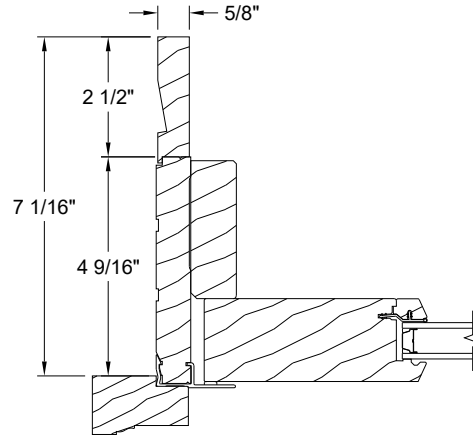

7 1/16" Jamb Extender

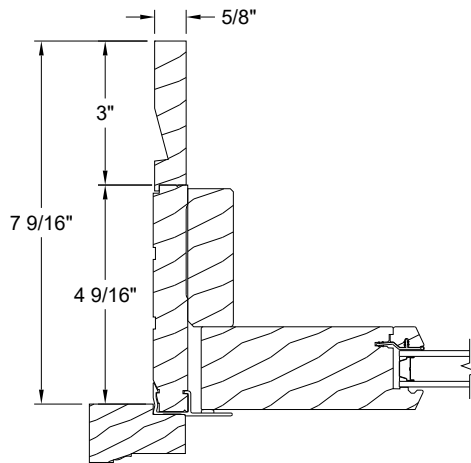

7 9/16" Jamb Extender

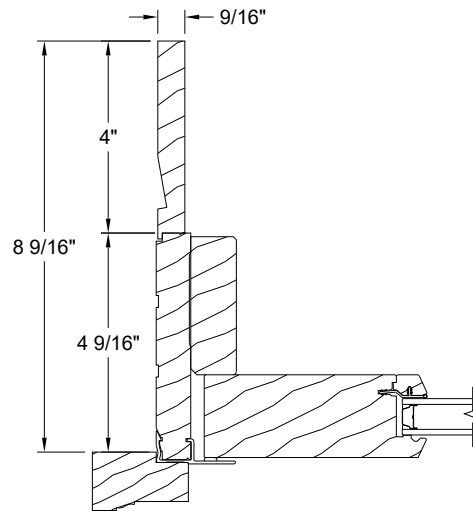

8 9/16" Jamb Extender

MULLION OPTIONS

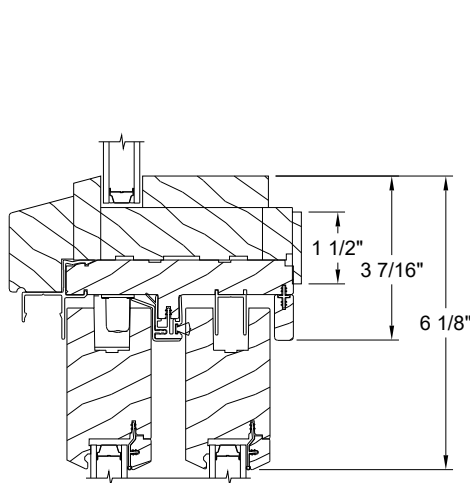

Direct Set
2 Panel

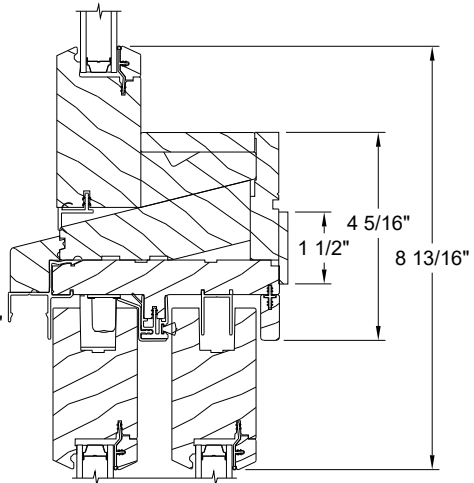

Transom
2 Panel

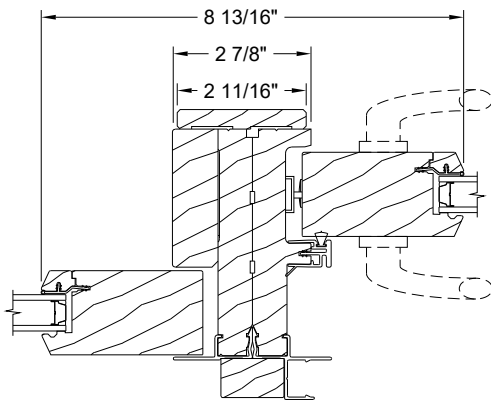

Stationary / 2 Panel

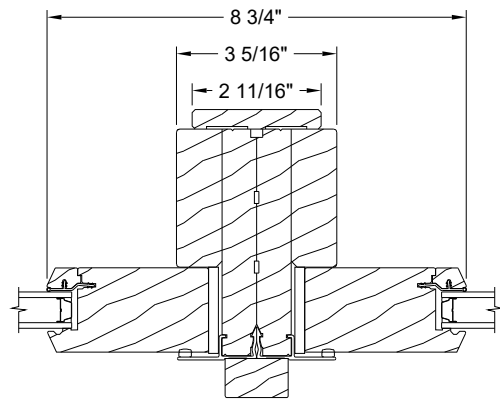

Transom / Transom

NARROW STILE OPERATOR SECTIONS

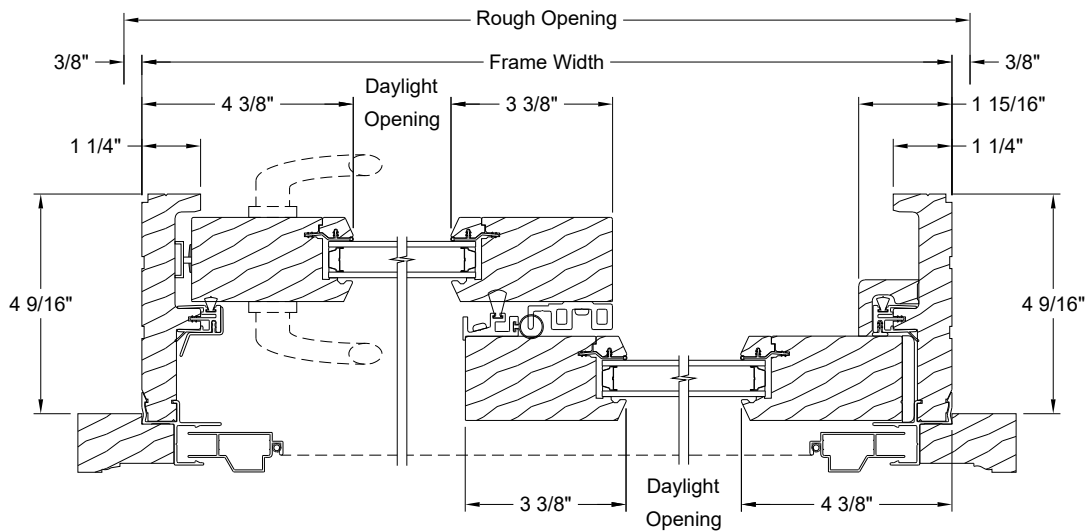
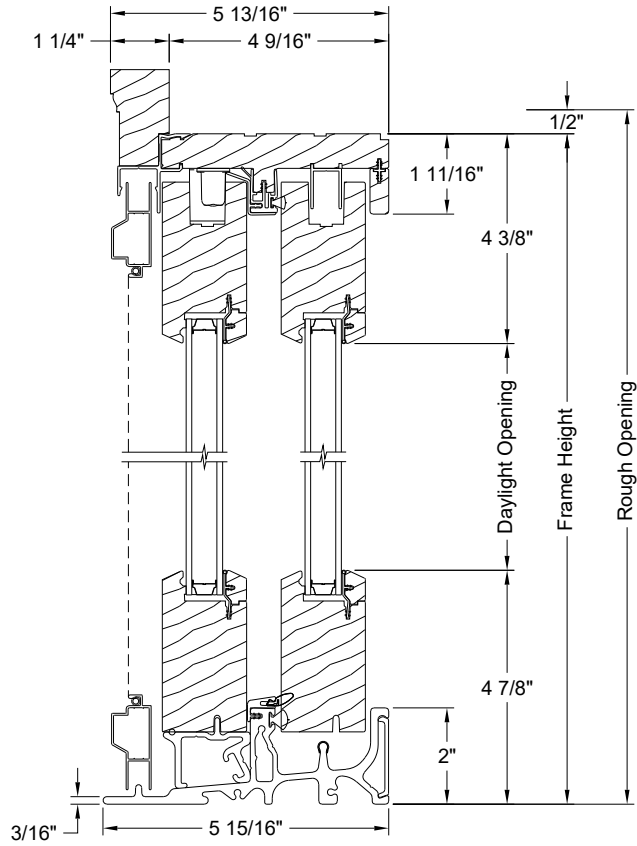

NARROW STILE 4 PANEL OPERATOR - HORIZONTAL SECTIONS

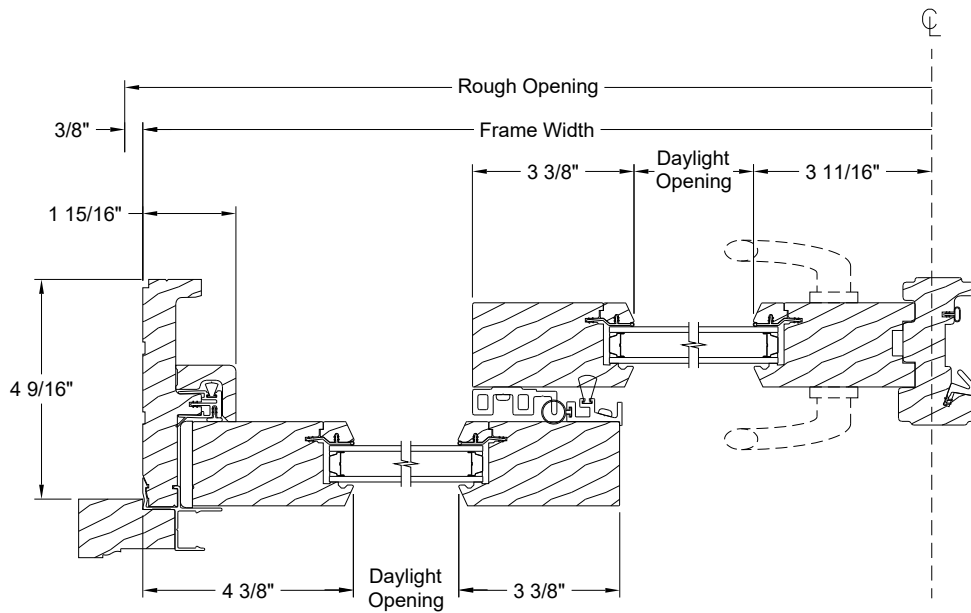
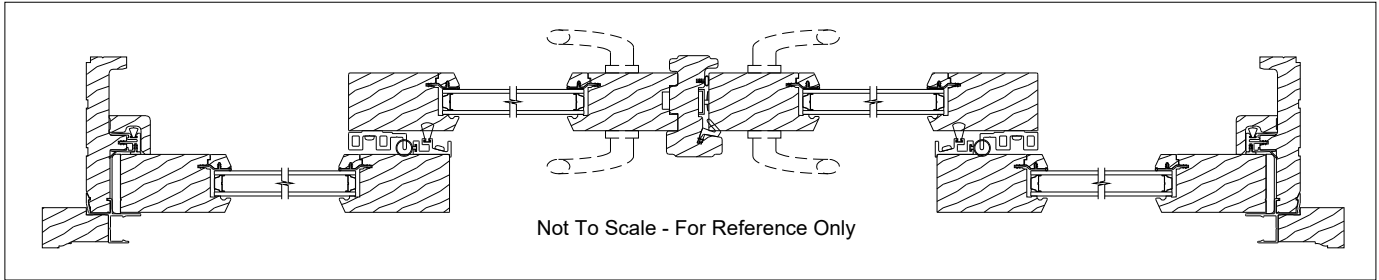

View symmetrical across centerline except astragal

WIDE STILE OPERATOR SECTIONS

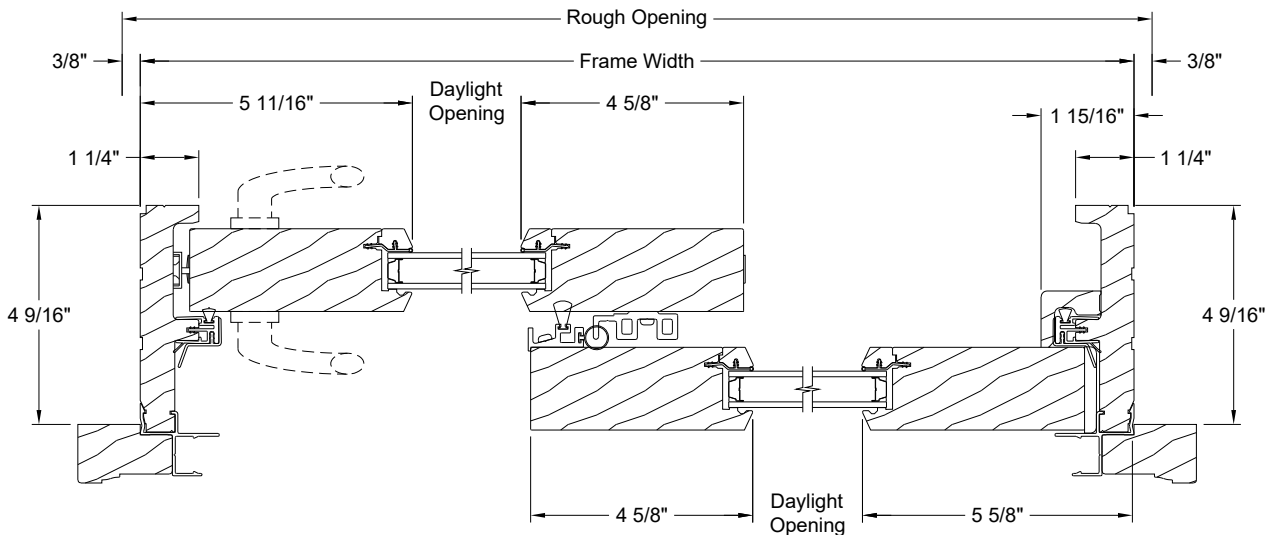
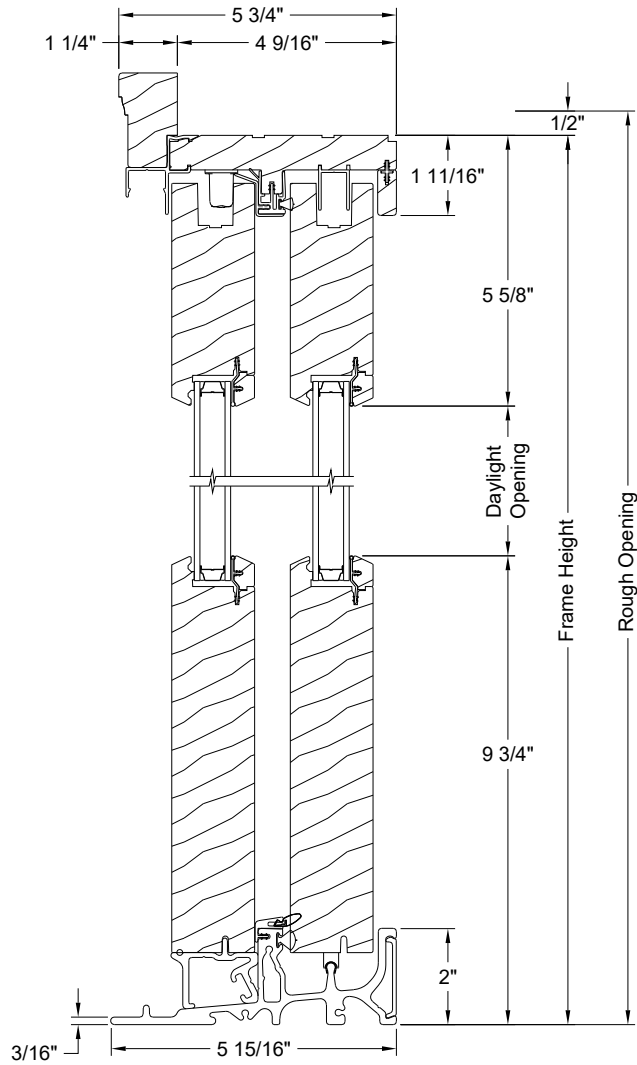

WIDE STILE 4 PANEL OPERATOR - HORIZONTAL SECTIONS

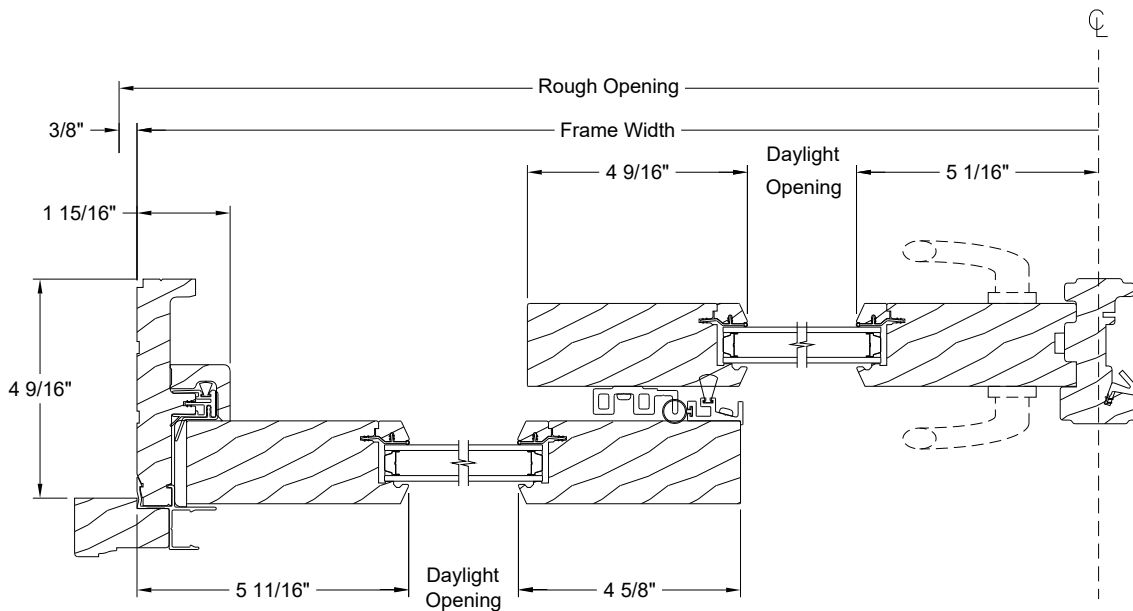
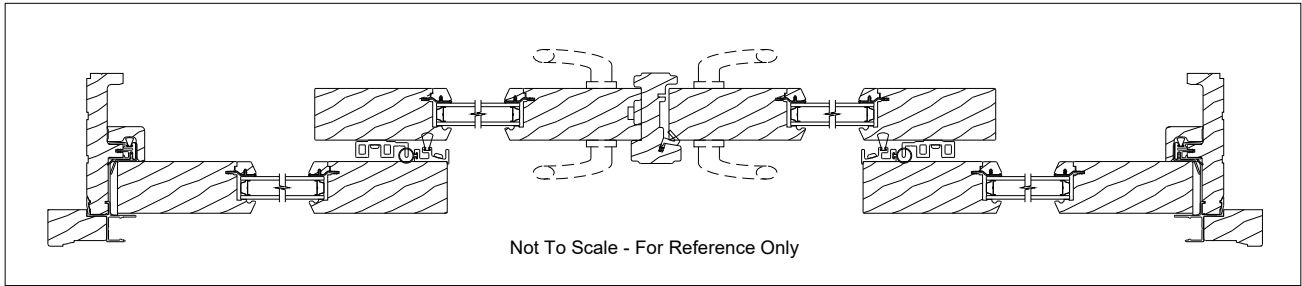

View symmetrical across centerline except astragal and panel hardware

WIDE STILE STATIONARY SECTIONS

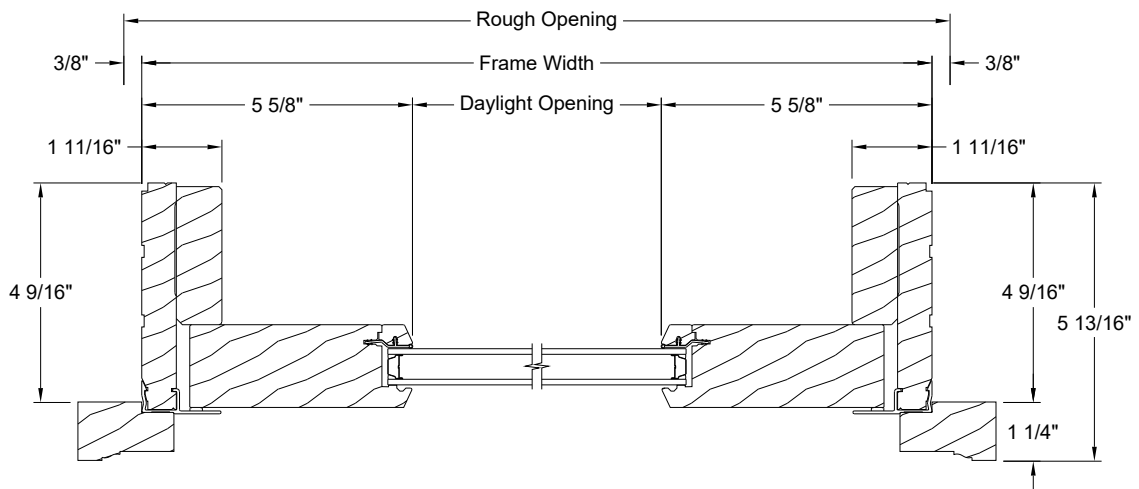
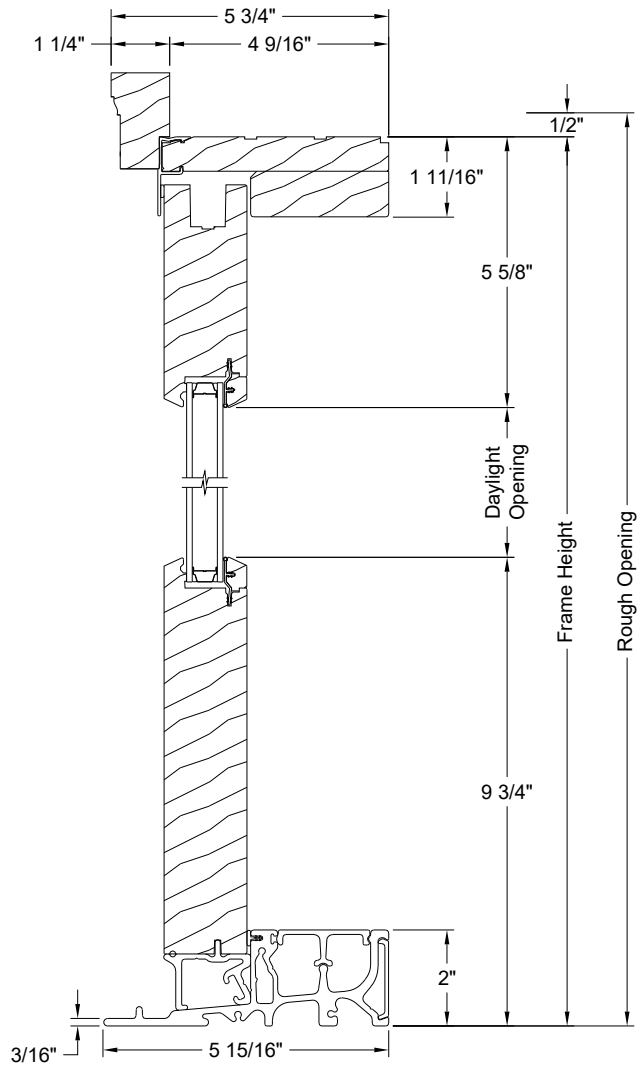

WIDE STILE TRANSOM SECTIONS

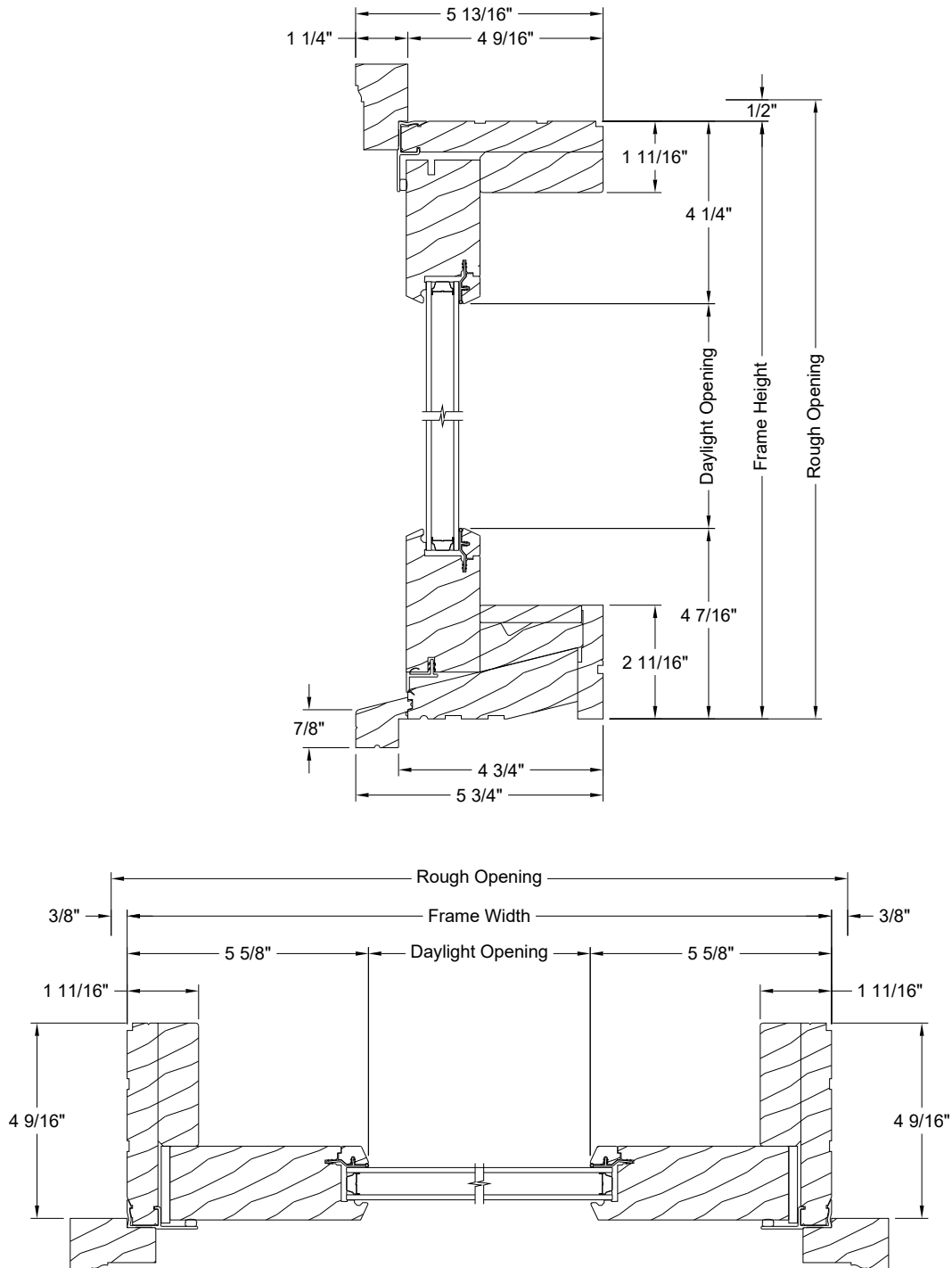

FORMULAS

Understanding JELD-WEN Book Codes:

Siteline® Product	Prefix	Width Code	Height Code
Wood Sliding Patio Door Wide Stile	TWSLDW	WW	HH
Wood Sliding Patio Door Narrow Stile	TWSLDN		
Wood Sliding Patio Door Transom Wide Stile	TWSLDTW		
Wood Sliding Patio Door Transom Narrow Stile	TWSLDTN		

Sample Book Codes:

TWSLDW5068 = Siteline® Wood Sliding Patio Door Wide Stile, 5'-0" x 6'-8" Frame Size

TWSLDTN2914 = Siteline® Wood Sliding Patio Door Transom Narrow Stile, 2'-9" x 1'-4" Frame Size

Formulas		
Rough Opening	$(\text{Frame Width} + 3/4") \times (\text{Frame Height} + 1/2")$	
Masonry Opening	$(\text{Overall Width} + 1/2") \times (\text{Overall Height} + 1/2")$	
Daylight Opening ft ² - 1 Panel Wide Stile	$((\text{Frame Width} - 11 1/4") \times (\text{Frame Height} - 15 3/8")) / 144$	
Daylight Opening ft ² - 2 Panel Wide Stile	$((\text{Frame Width} / 2 - 8 1/16") \times (\text{Frame Height} - 15 3/8")) / 144$	
Daylight Opening ft ² - 4 Panel Wide Stile	$((\text{Frame Width} / 4 - 7 25/32") \times (\text{Frame Height} - 15 3/8")) / 144$	
Daylight Opening ft ² - 1 Panel Narrow Stile	$((\text{Frame Width} - 8 11/16") \times (\text{Frame Height} - 9 3/16")) / 144$	
Daylight Opening ft ² - 2 Panel Narrow Stile	$((\text{Frame Width} / 2 - 6 3/16") \times (\text{Frame Height} - 9 3/16")) / 144$	
Daylight Opening ft ² - 4 Panel Narrow Stile	$((\text{Frame Width} / 4 - 5 29/32") \times (\text{Frame Height} - 9 3/16")) / 144$	
Clear Opening Horizontal	With Bumper	Without Bumper
2 Panel Narrow Stile	$(\text{Frame Width}/2) - 7 5/8"$	$(\text{Frame Width}/2) - 6 3/8"$
2 Panel Wide Stile	$(\text{Frame Width}/2) - 8 5/16"$	$(\text{Frame Width}/2) - 7 1/16"$
4 Panel Narrow Stile Both Panels Open	$(\text{Frame Width}/2) - 13 3/4"$	$(\text{Frame Width}/2) - 11 1/4"$
4 Panel Wide Stile Both Panels Open	$(\text{Frame Width}/2) - 15 1/8"$	$(\text{Frame Width}/2) - 12 5/8"$
4 Panel Narrow Stile Active Panel Open	$(\text{Frame Width} / 4) - 7 1/32"$	$(\text{Frame Width}/4) - 6 25/32"$
4 Panel Wide Stile Active Panel Open	$(\text{Frame Width}/4) - 7 23/32"$	$(\text{Frame Width}/4) - 6 15/32"$
Clear Opening Vertical		
All	Frame Height - 3 21/32"	

Note: "Overall" dimensions include frame and trim.

Unit elevations are shown without exterior trim.

MIN-MAX STANDARD SIZING

1 Panel Narrow Stile

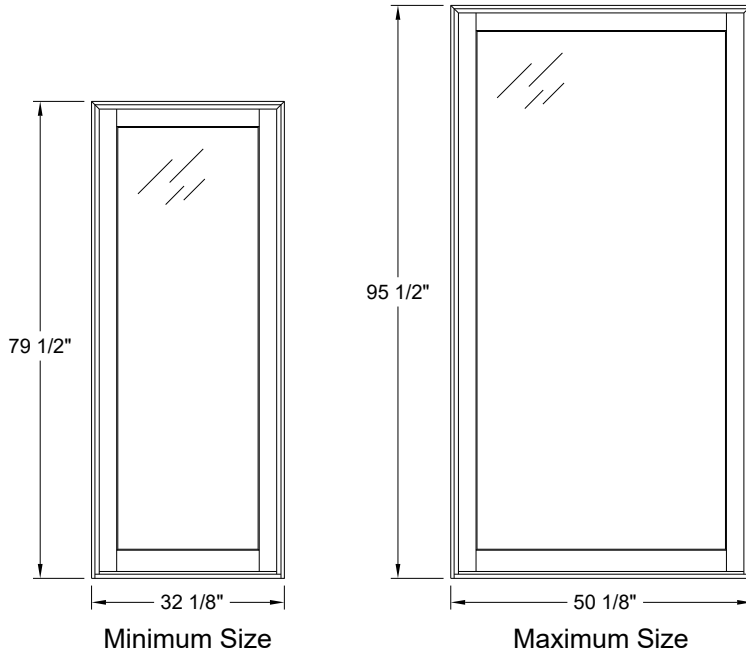

Standard Widths		
32 1/8"	38 1/8"	50 1/8"
Standard Heights		
79 1/2"	82 1/2"	95 1/2"

1 Panel Wide Stile

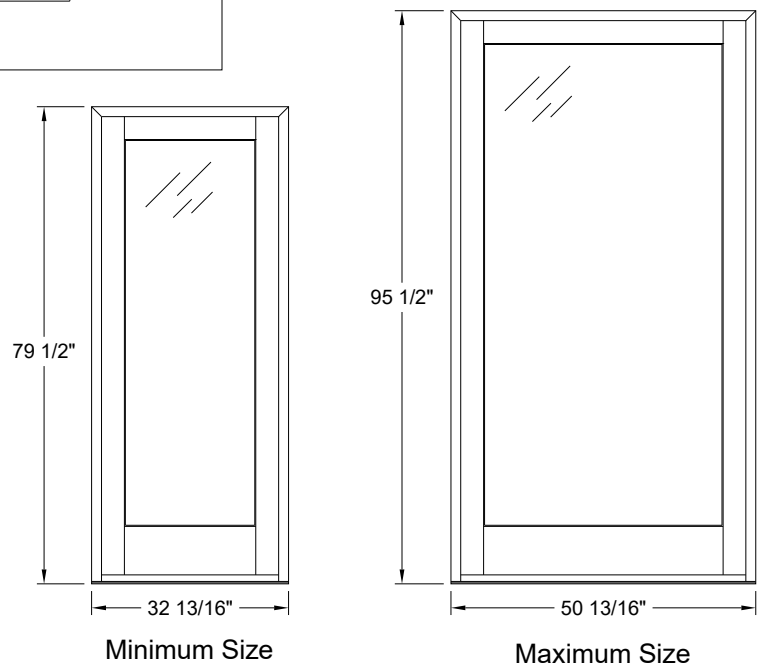

Standard Widths		
32 13/16"	38 13/16"	50 13/16"
Standard Heights		
79 1/2"	82 1/2"	95 1/2"

MIN-MAX STANDARD SIZING

2 Panel - Wide & Narrow Stile

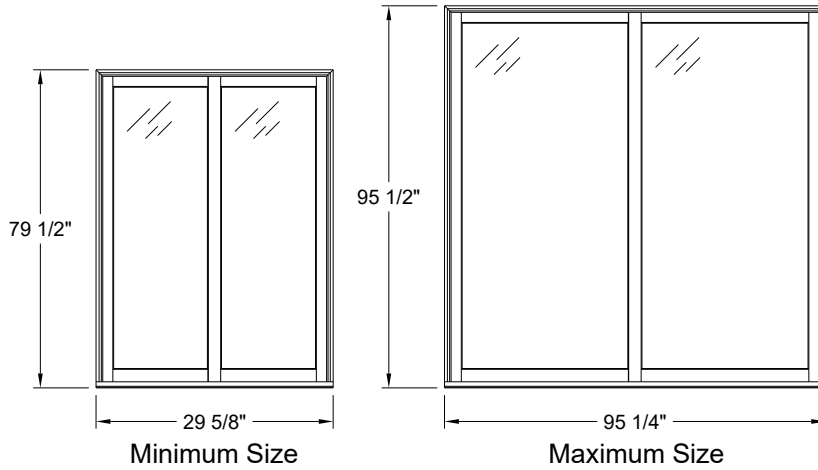

Standard Widths		
59 1/4"	71 1/4"	95 1/4"
Standard Heights		
79 1/2"	82 1/2"	95 1/2"

4 Panel - Wide & Narrow Stile

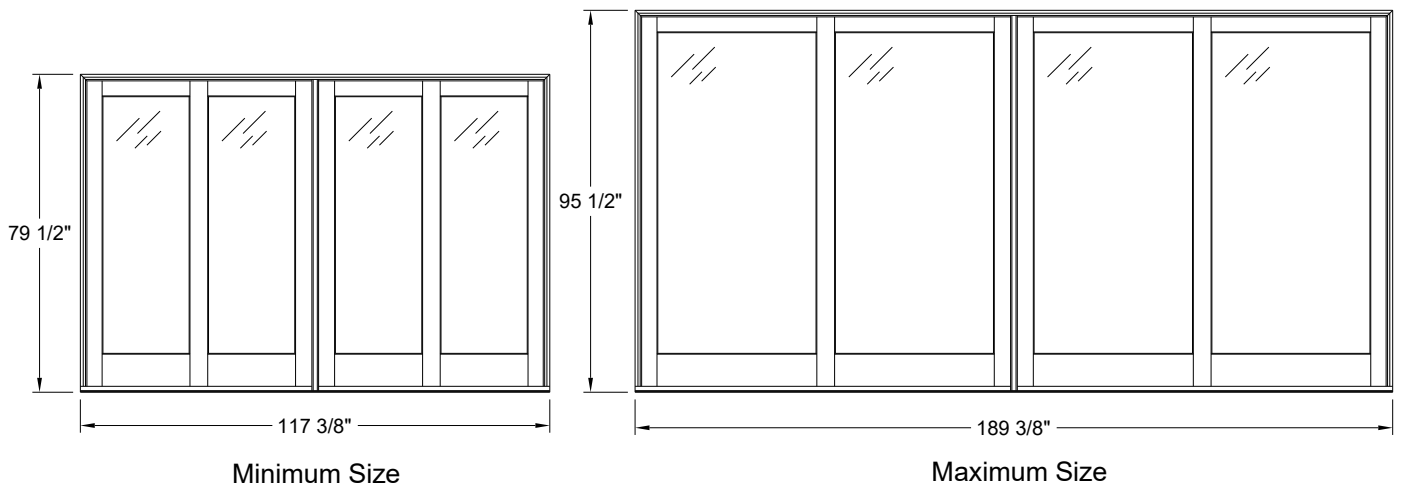

Standard Widths		
117 3/8"	141 3/8"	189 3/8"
Standard Heights		
79 1/2"	82 1/2"	95 1/2"

Sizing is the same for narrow and wide stile units.

MIN-MAX STANDARD SIZING

Transom - Narrow Stile

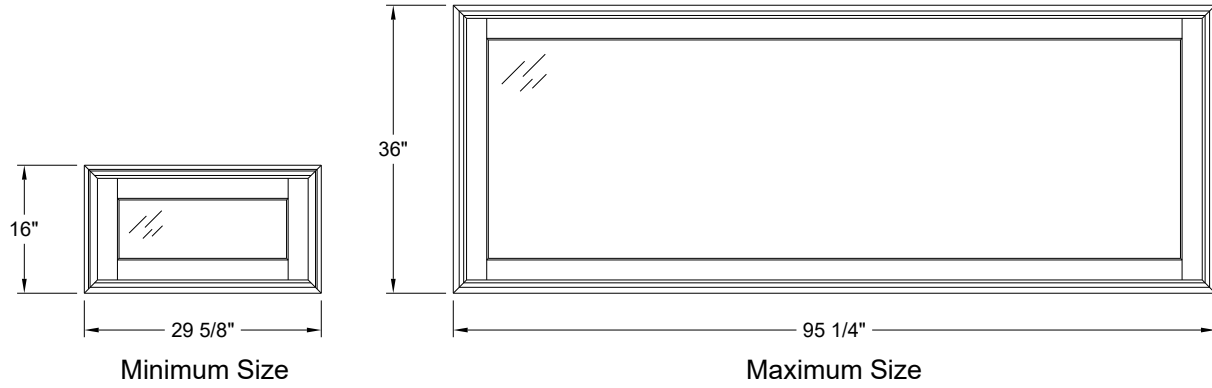

Standard Widths				
29 5/8"	32 1/8"	35 5/8"	38 1/8"	47 5/8"
50 1/8"	59 1/4"	71 1/4"	95 1/4"	
Standard Heights				
16"	24"	36"		

Transom - Wide Stile

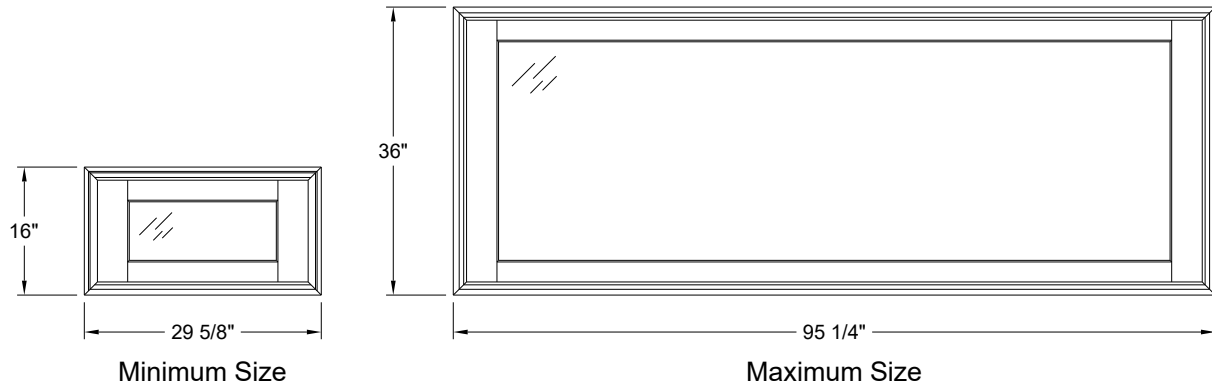

Standard Widths				
29 5/8"	32 1/8"	35 5/8"	38 1/8"	47 5/8"
50 1/8"	59 1/4"	71 1/4"	95 1/4"	
Standard Heights				
16"	24"	36"		

1 PANEL WIDE STILE UNITS

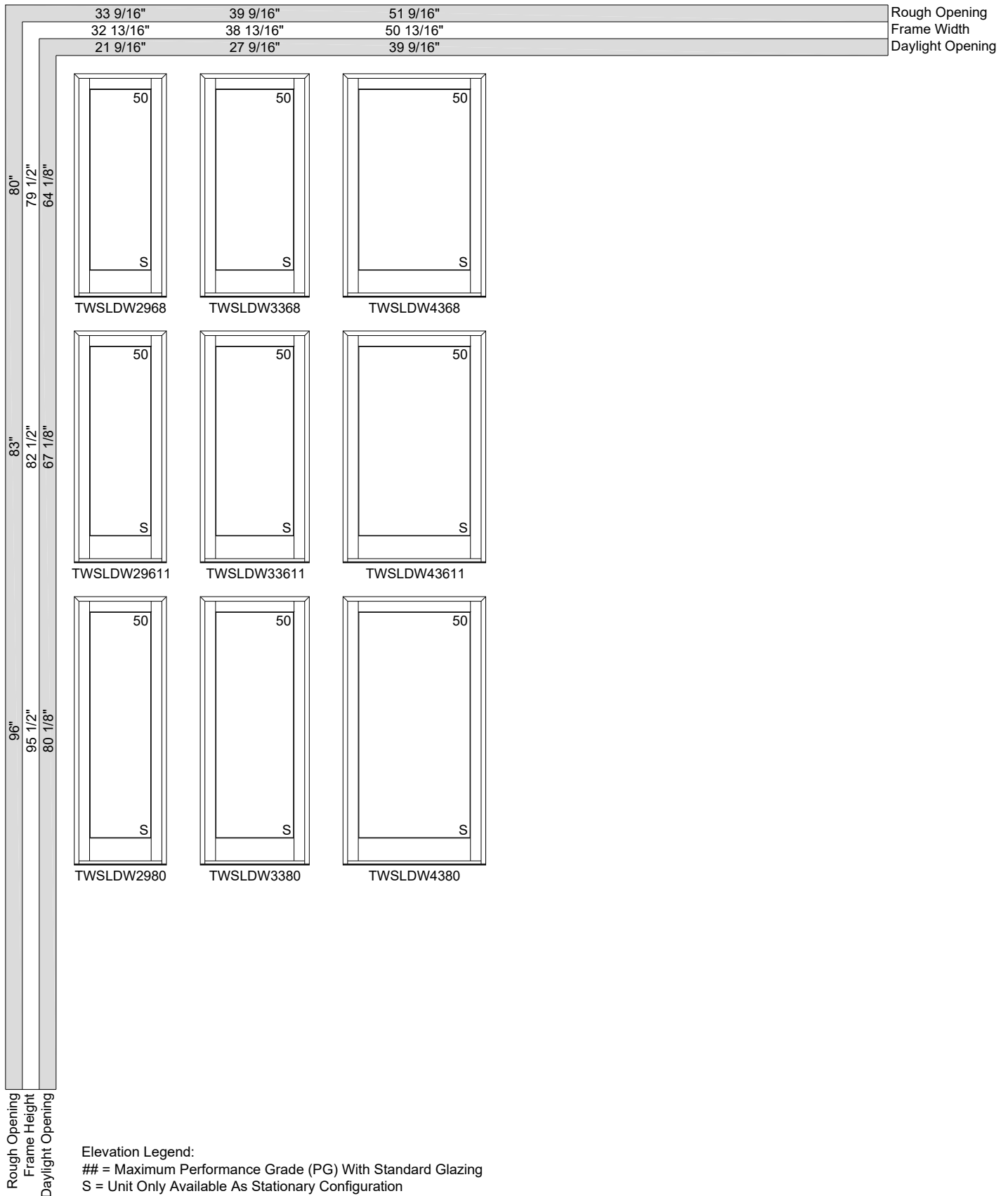

2 PANEL WIDE STILE UNITS

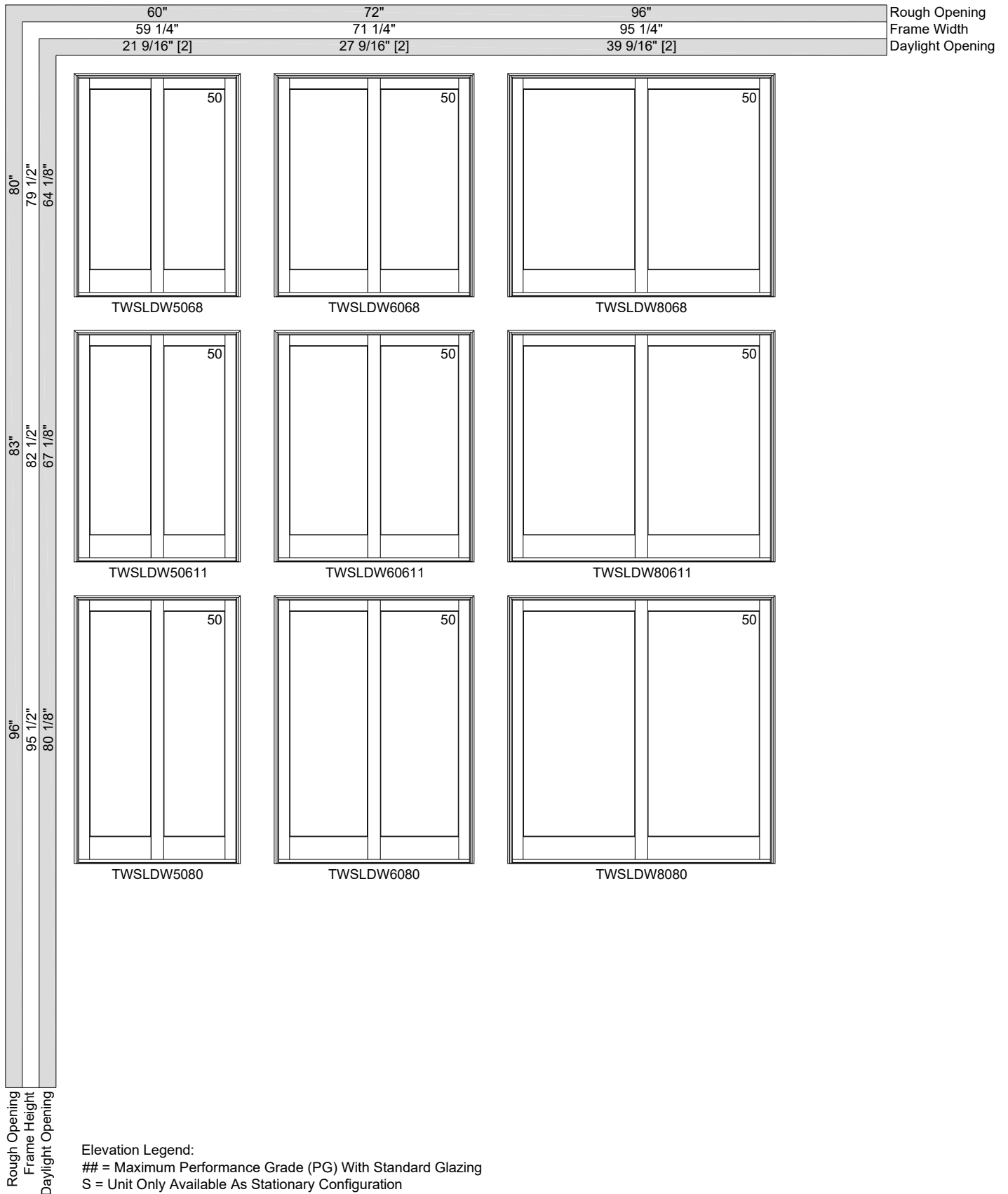

4 PANEL WIDE STILE UNITS

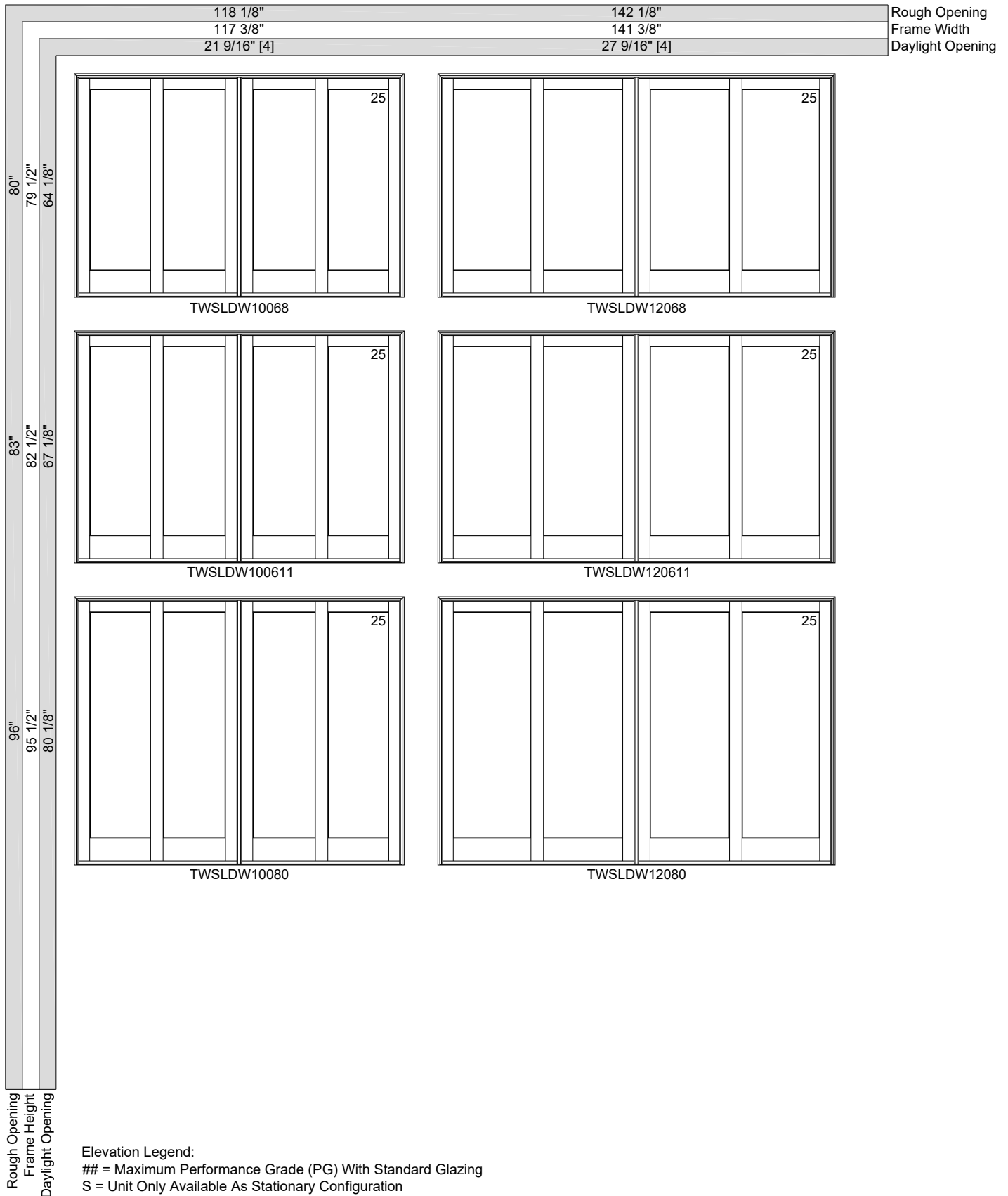

4 PANEL WIDE STILE UNITS

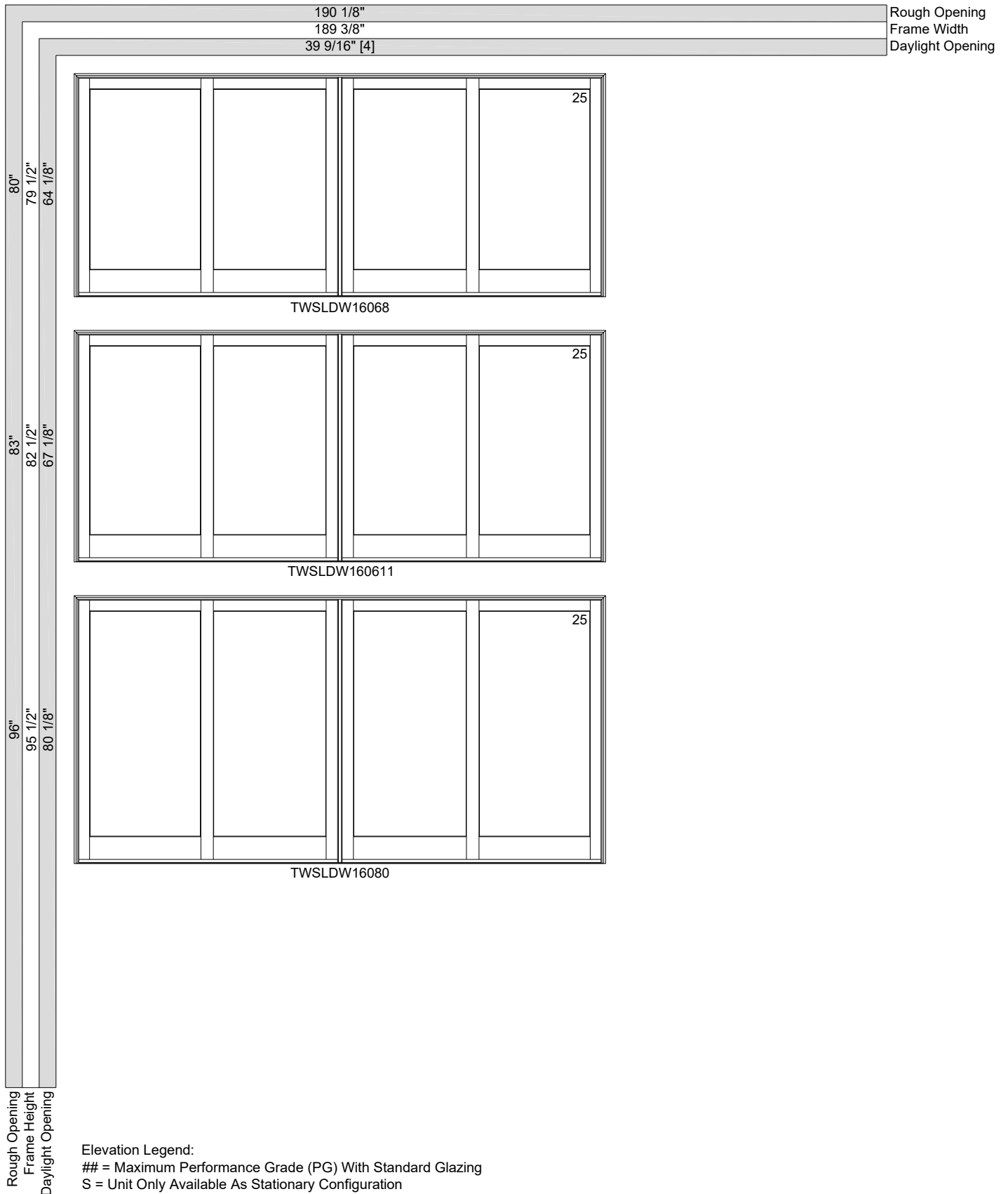

TRANSOM WIDE STILE UNITS

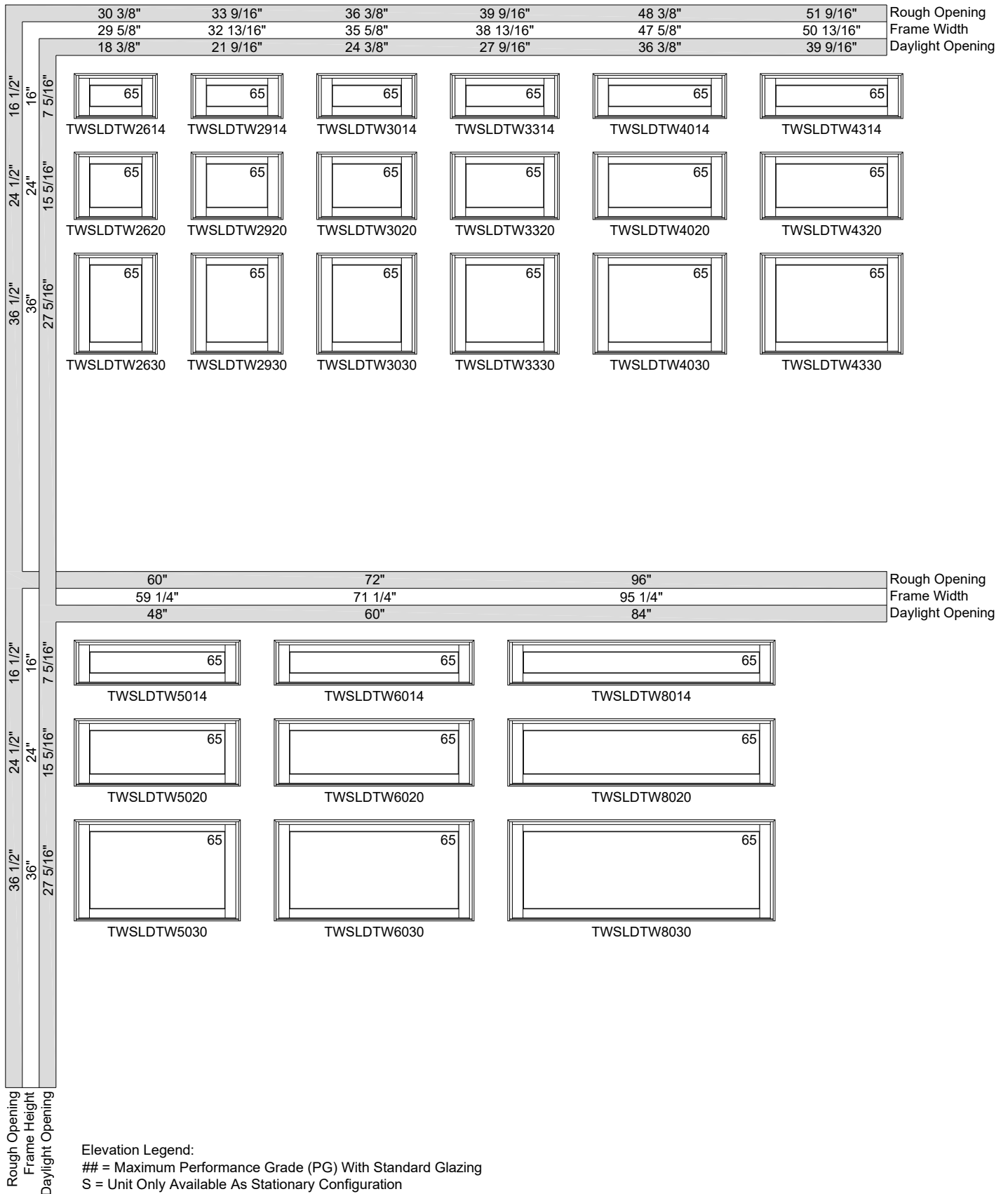

1 PANEL NARROW STILE UNITS

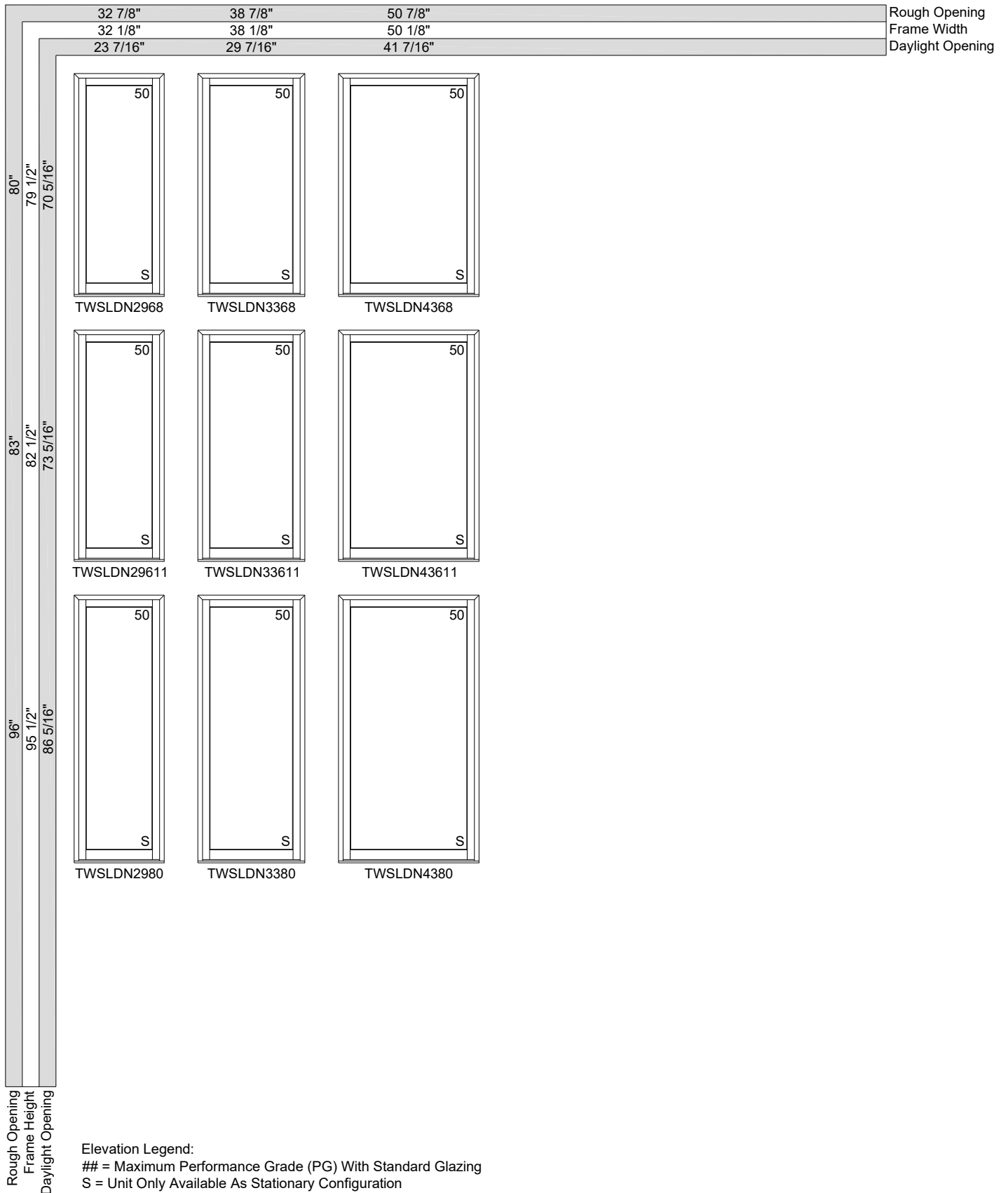

2 PANEL NARROW STILE UNITS

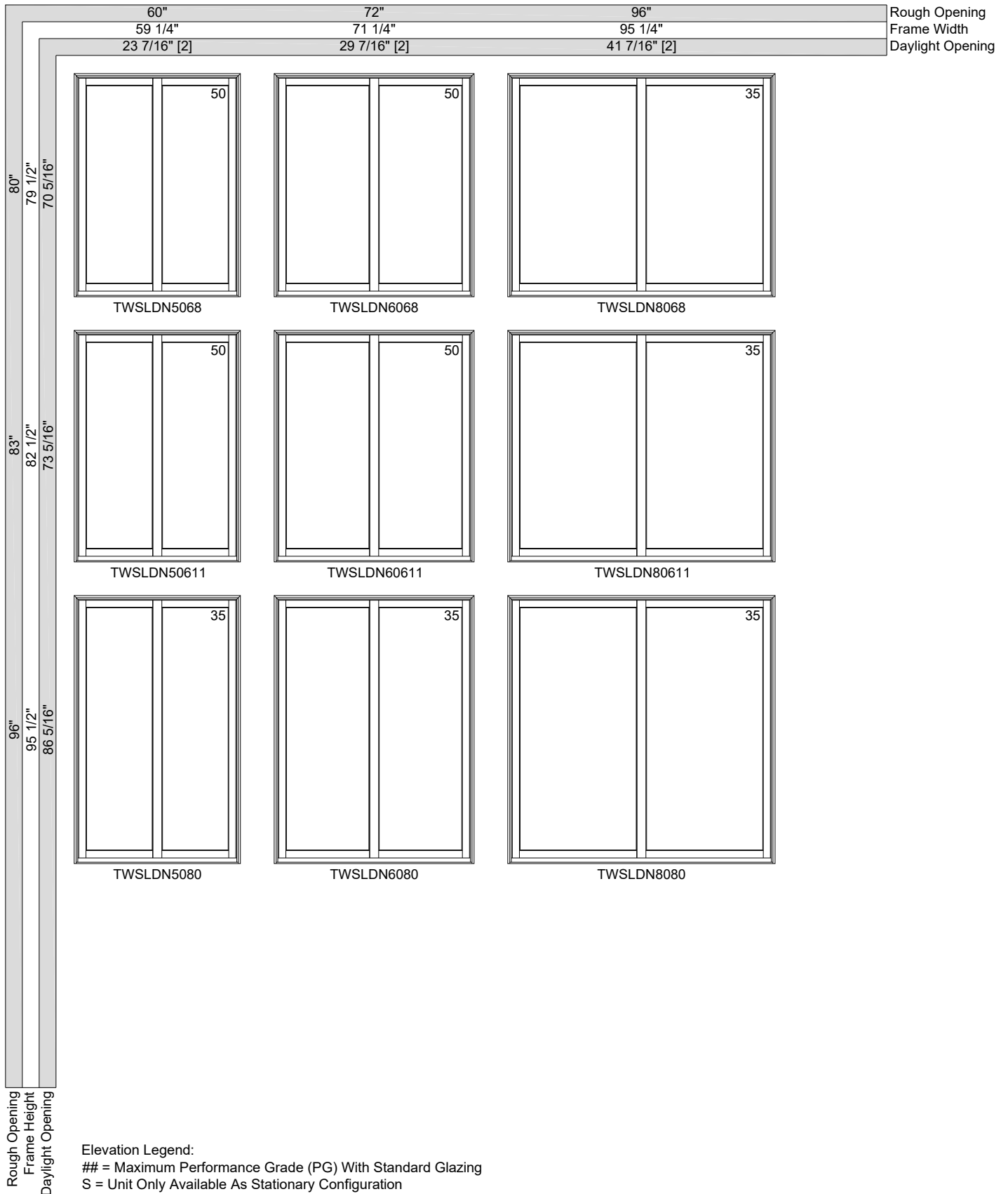

4 PANEL NARROW STILE UNITS

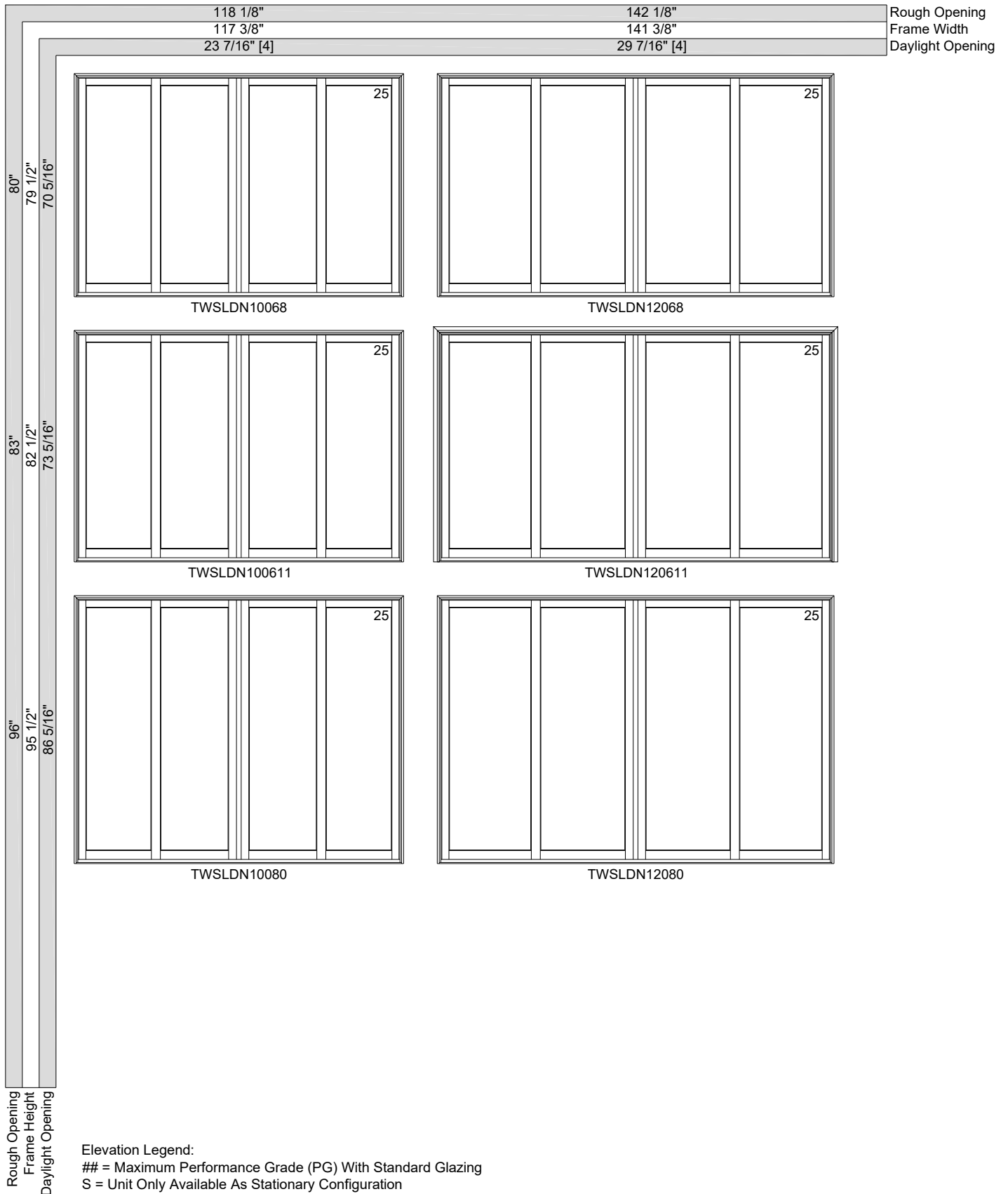

4 PANEL NARROW STILE UNITS

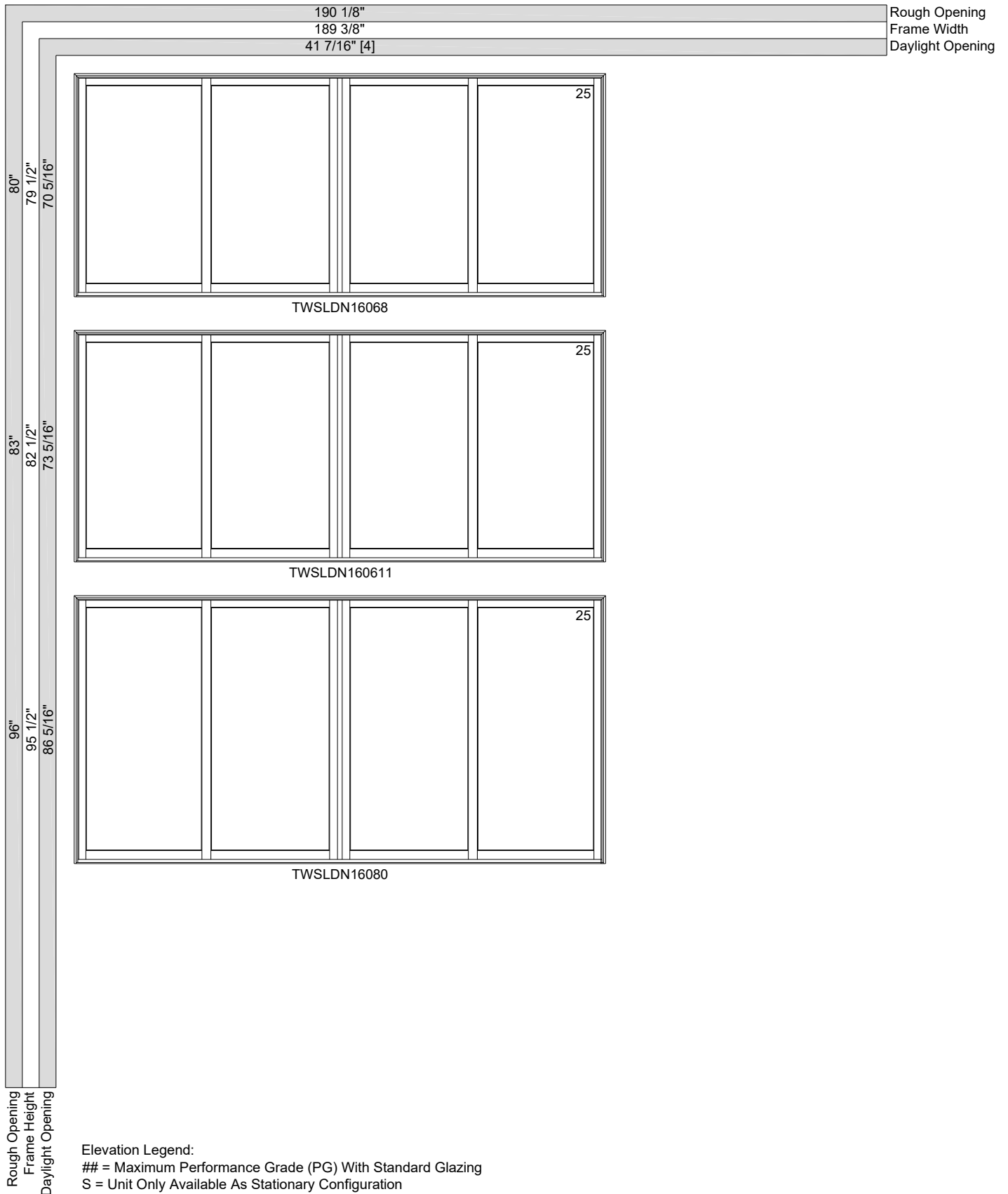

TRANSOM NARROW STILE UNITS

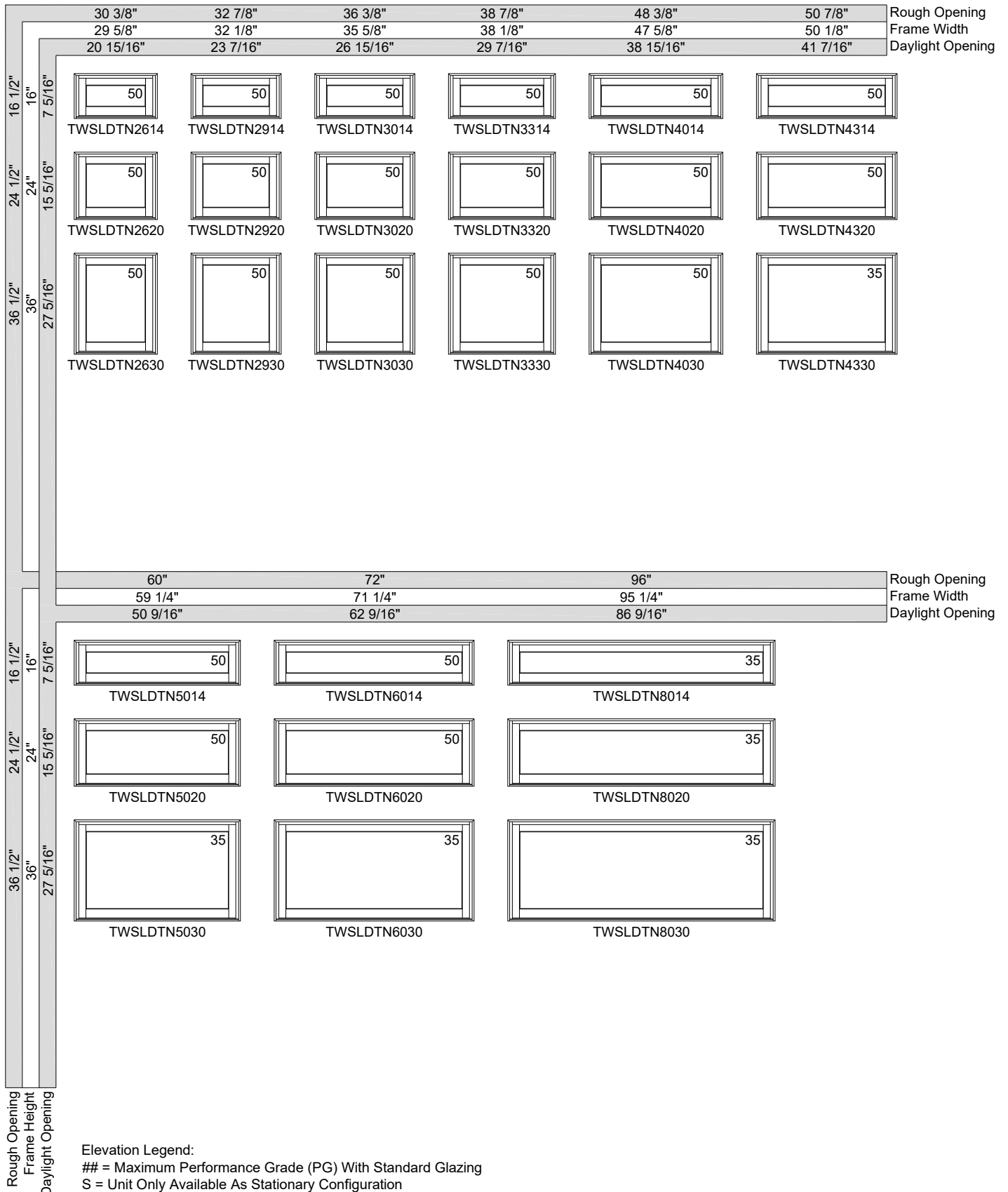

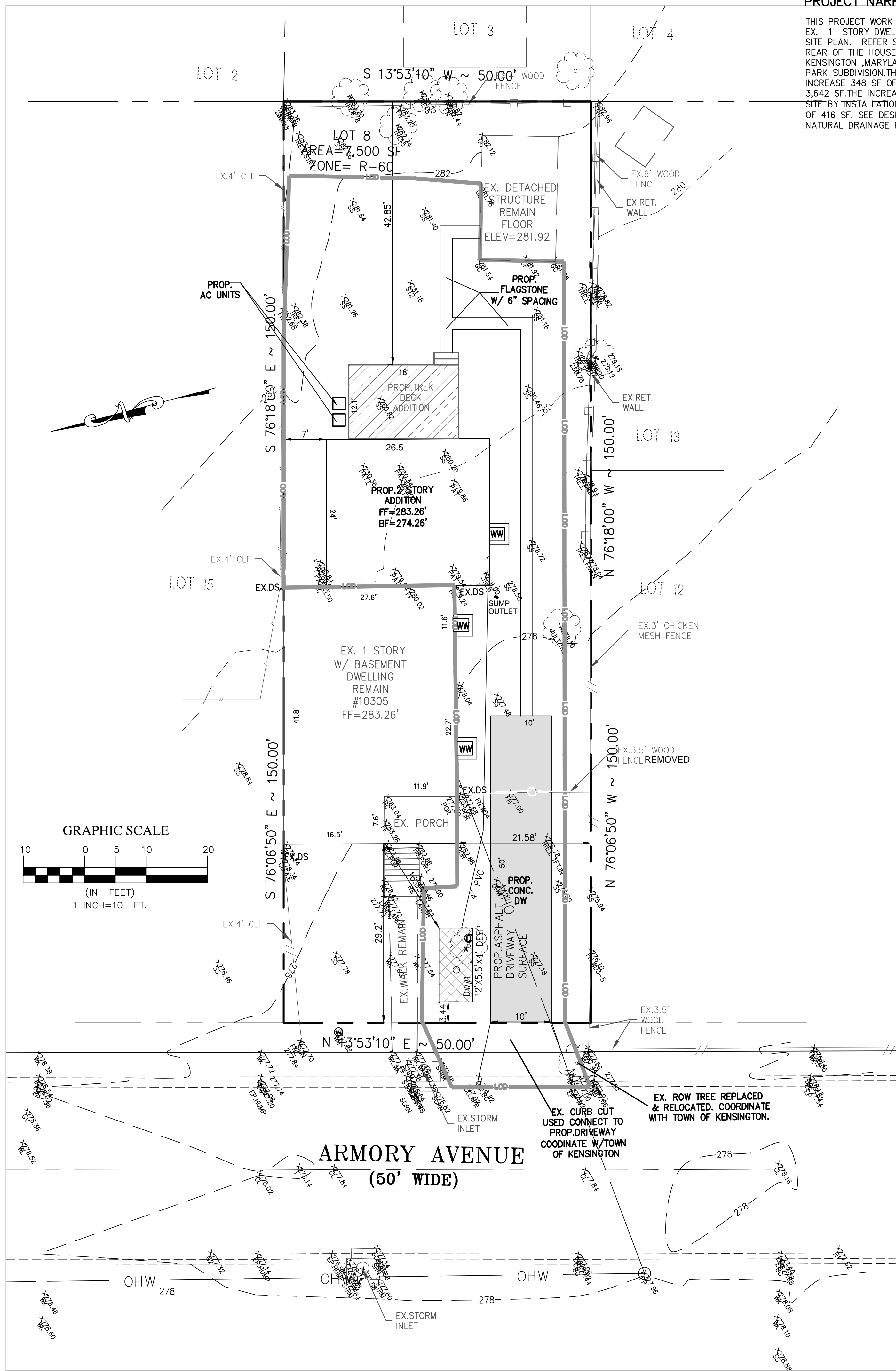

PROJECT NARRATIVE :

THIS PROJECT WORK INVOLVES ADDITION OF TWO LEVELLY STRUCTURES AND DECK ON REAR OF THE EX. 1 STORY DWELLING. IT ALSO INCLUDES INSTALLATION OF DRIVEWAY ENTRANCE AS SHOWN IN SITE PLAN. REFER SHEET 2. THE EX. DETACHED STRUCTURES REMAINS AS IT IS. THE EX. PATIO ON REAR OF THE HOUSE SHALL BE REMOVED. THE PROJECT SITE IS KNOWN AS 10305 ARMORY AVENUE, KENSINGTON MARYLAND 20895. THIS PROPERTY ALSO KNOWN AS LOT 8, BLOCK 9, KENSINGTON PARK SUBDIVISION. THE SITE CONTAINS 7,500 SF OF LAND. THE PROPOSED DEVELOPMENT WILL INCREASE 348 SF OF IMPERVIOUS AREA. THE DISTURBED AREA DUE TO PROPOSED ADDITION WORK IS 3,642 SF. THE INCREASED IN RUNOFF VOLUME GENERATED BY PROPOSED ADDITIONS WILL CONTROL ON SITE BY INSTALLATION OF ONE (1) DRYWELL. THE PROPOSED DRYWELL WILL CONTROL ROOF AREA OF 416 SF. SEE DESIGN AND DETAILS ON SHEET 2. THE PROPOSED ADDITIONS WILL HONOR NATURAL DRAINAGE PATTERN. THERE WILL NOT BE NEGATIVE IMPACT ON ADJACENT PROPERTY.

MAXIMUM ALLOWABLE LOT COVERAGE

LOT AREA = 7,500 SF
 MINUS = - 6,000 SF
 = 1,500 SF
 MULTIPLY TIMES * 0.001
 = 1.5 %
 ALLOWABLE LOT COVERAGE = 30-1.5= 28.50%
 MAXIMUM ALLOWABLE BUILDING AREA = 2,137.5 SF

EX. BUILDING = 1,083 SF
 EX. PORCH = 87 SF
 SUB TOTAL = 1,170 SF
 NEW ADDITION = 648 SF

TOTAL = 1,818 SF
 LOT COVERAGE = 1,818/7,500= 24.24 % < 28.50 % OK

EX. DETACHED STRUCTURE = 251 SF
 EX. WALKWAY AND STEPS = 141 SF
 EX. PATIO = 354 SF (TO BE REMOVED)
 TOTAL PRE DEVELOPMENT IMP AREA= 2,564 SF

NEW DECK ADDITION = 215 SF
 DRIVEWAY SURFACE AREA = 500 SF
 NEW WALK SURFACE AREA = 202 SF
 PROPOSED NEW IMPERVIOUS AREA = 702 SF
 INCREASED IN IMPERVIOUS AREA = 702 SF- 354 SF (EX. PATIO)= 348 SF
 TOTAL POST DEVELOPMENT IMP AREA= 2,912 SF

SAND SPECIFICATIONS:
 WASHED ASTM C33 FINE AGGREGATE CONCRETE SAND IS UTILIZED FOR STORMWATER MANAGEMENT APPLICATIONS IN MONTGOMERY COUNTY. IN ADDITION TO THE ASTM C33 SPECIFICATION, SAND MUST MEET ALL OF THE FOLLOWING CONDITIONS:
 1. SAND MUST MEET GRADATION REQUIREMENTS FOR ASTM C-33 FINE AGGREGATE CONCRETE SAND. AASHTO M-6 GRADATION IS ALSO ACCEPTABLE.
 2. SAND MUST BE SILICA BASED, NO LIMESTONE BASED PRODUCTS MAY BE USED. IF THE MATERIAL IS WHITE OR GRAY IN COLOR, IT IS PROBABLY NOT ACCEPTABLE.
 3. SAND MUST BE CLEAN, NATURAL, UNWASHED SAND DEPOSITS MAY NOT BE USED. LIKEWISE, SAND THAT HAS BECOME CONTAMINATED BY IMPROPER STORAGE OR INSTALLATION PRACTICES WILL BE REJECTED.
 4. MANUFACTURED SAND OR STONE DUST IS NOT ACCEPTABLE UNDER ANY CIRCUMSTANCE

ESD INSPECTION CHECKLISTS

STAGE	MCDPS INSPECTOR INITIALS/DATE	OWNER/DEVELOPER INITIALS/DATE
1. Excavation for Dry Well conforms to approved plans		
2. Placement of backfill, perforated inlet pipe and observation well conforms to approved plans		
3. Placement of geotextiles and filter media conforms to approved plans		
4. Connecting pipes, including connection to downspout, constructed per the approved plans		
5. Final grading and permanent stabilization conforms to approved plans		

TOTAL NUMBER OF DRY WELLS INSTALLED PER THIS PERMIT: APPROVED 1
 CONSTRUCTED _____

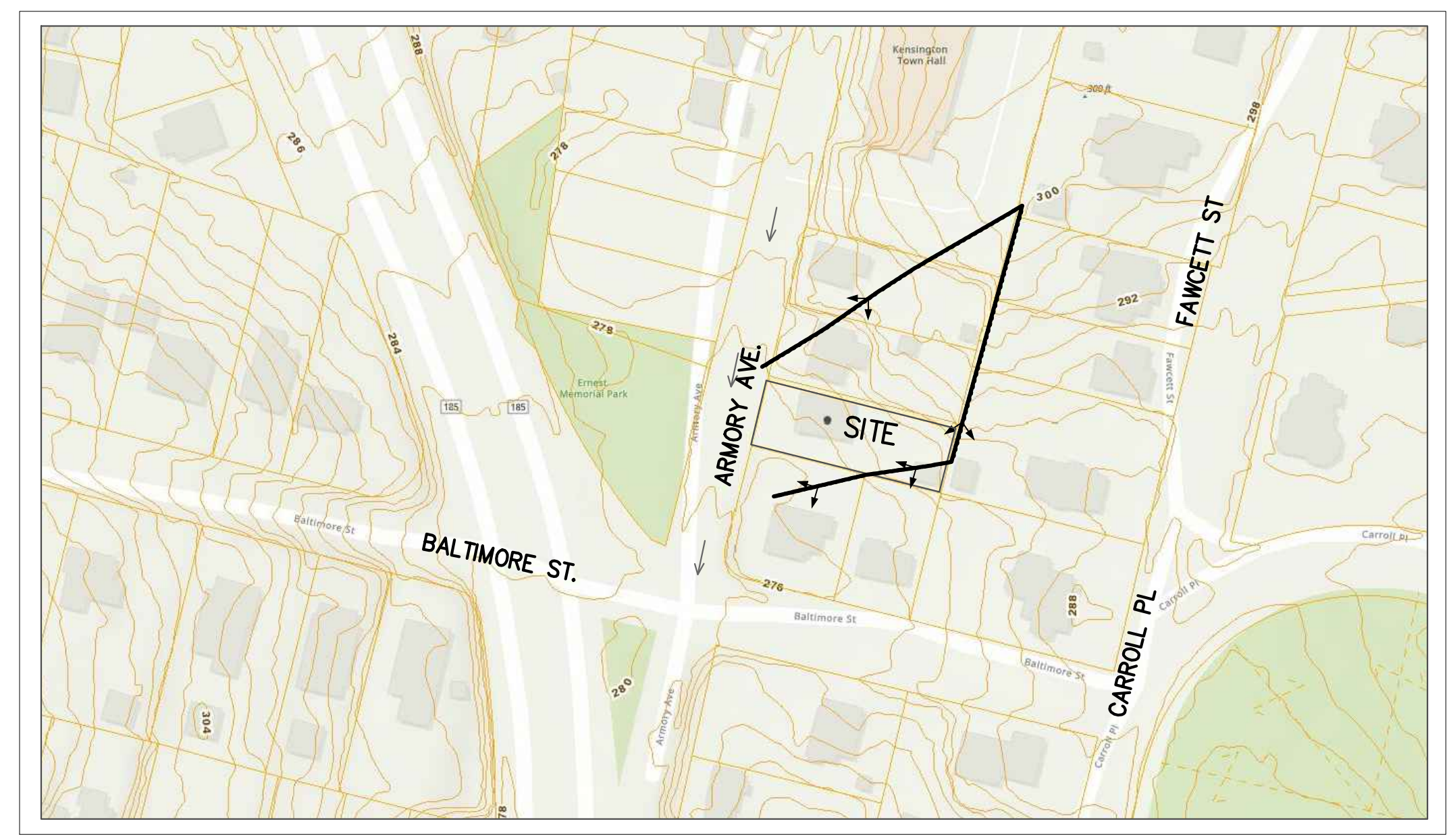

VICINITY MAP
 SCALE: 1"=100'

PROPOSED INCREASED IN ROOF AREA= 648 SF

DRYWELL SIZING (Chapter 8, Section 8-29B, Montgomery county code)	Drywell Size (FT)
Roof Square footage (SF)	
100	3 X 3 X 3.5
200	4 X 4 X 3.5
400	6 X 6 X 3.5
500	6 X 6 X 4
1000	9 X 9 X 4

PROPOSED DRYWELL 12.0'x5.5' x4.0' DEEP = 264 CF

DRYWELL DETAIL INFORMATION								
DRYWELL#	FINISH GRADE HIGHER SIDE	COVERAGE HIGHER SIDE	FINISH GRADE LOWER SIDE	COVERAGE LOWER SIDE	TOP OF GRAVEL	INVERT OF PIPE	BOTTOM OF GRAVEL	BOTTOM OF SAND BASE
DW#FRONT	277.50 ft	1.20 ft	277.30 ft	1.00 ft	276.30 ft	275.80 ft	272.30 ft	271.30 ft

GENERAL NOTES:

- Dry wells may receive water from roof downspouts only.
- Length, width, and depth of each dry well is to be as specified by the design engineer on the approved plan.
- Manufactured sand is not acceptable. Refer to the MCDPS Sand Specifications.
- With the Inspector's approval, dry well locations may be field adjusted for site conditions. All adjustments must meet the minimum setbacks.
- Impermeable liners may be used when specified by the design engineer and shown on the plan.
- Overflow pipes may be used when specified by the design engineer and shown on the plan. They shall be set at a minimum 2% slope. If the outlet is to daylight the outlet invert shall be shown.
- Pop-up emitters may be used when specified by the design engineer and shown on the plan.

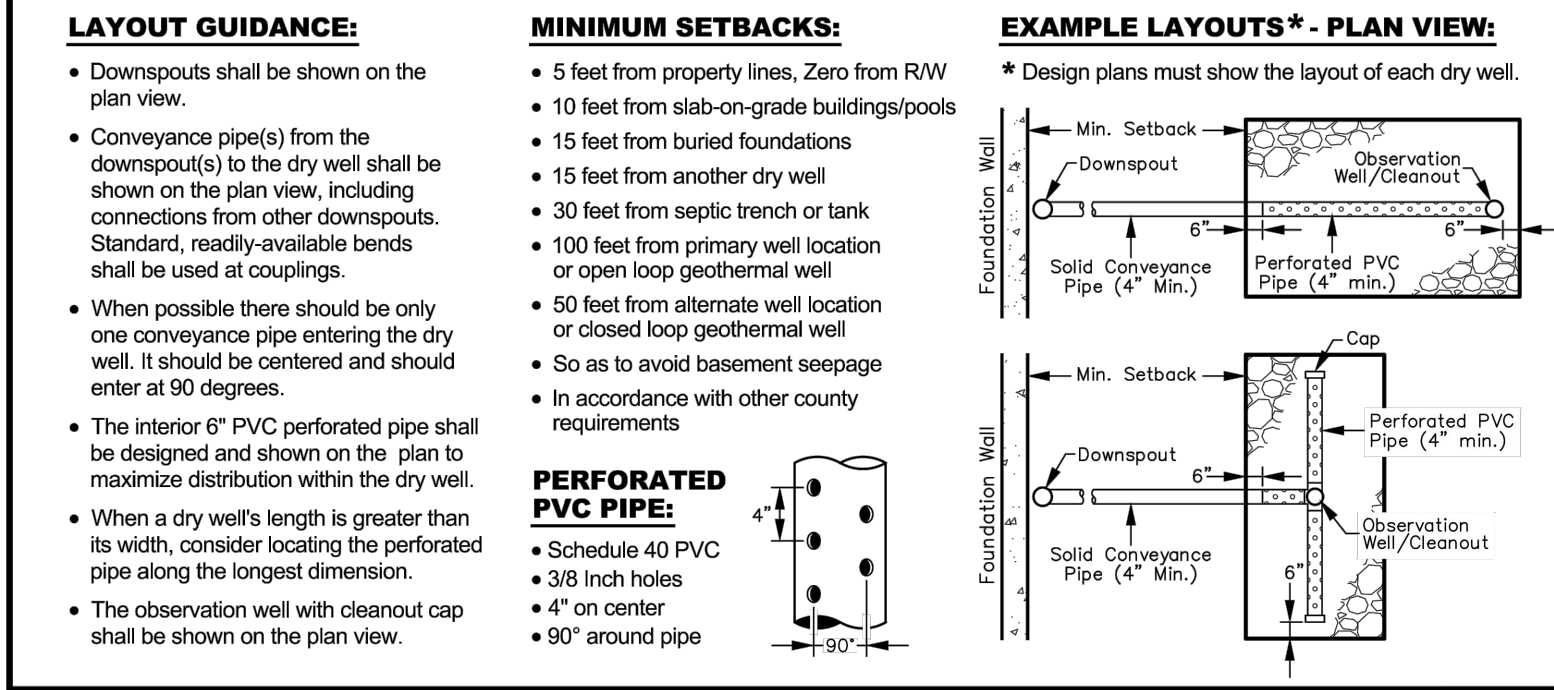
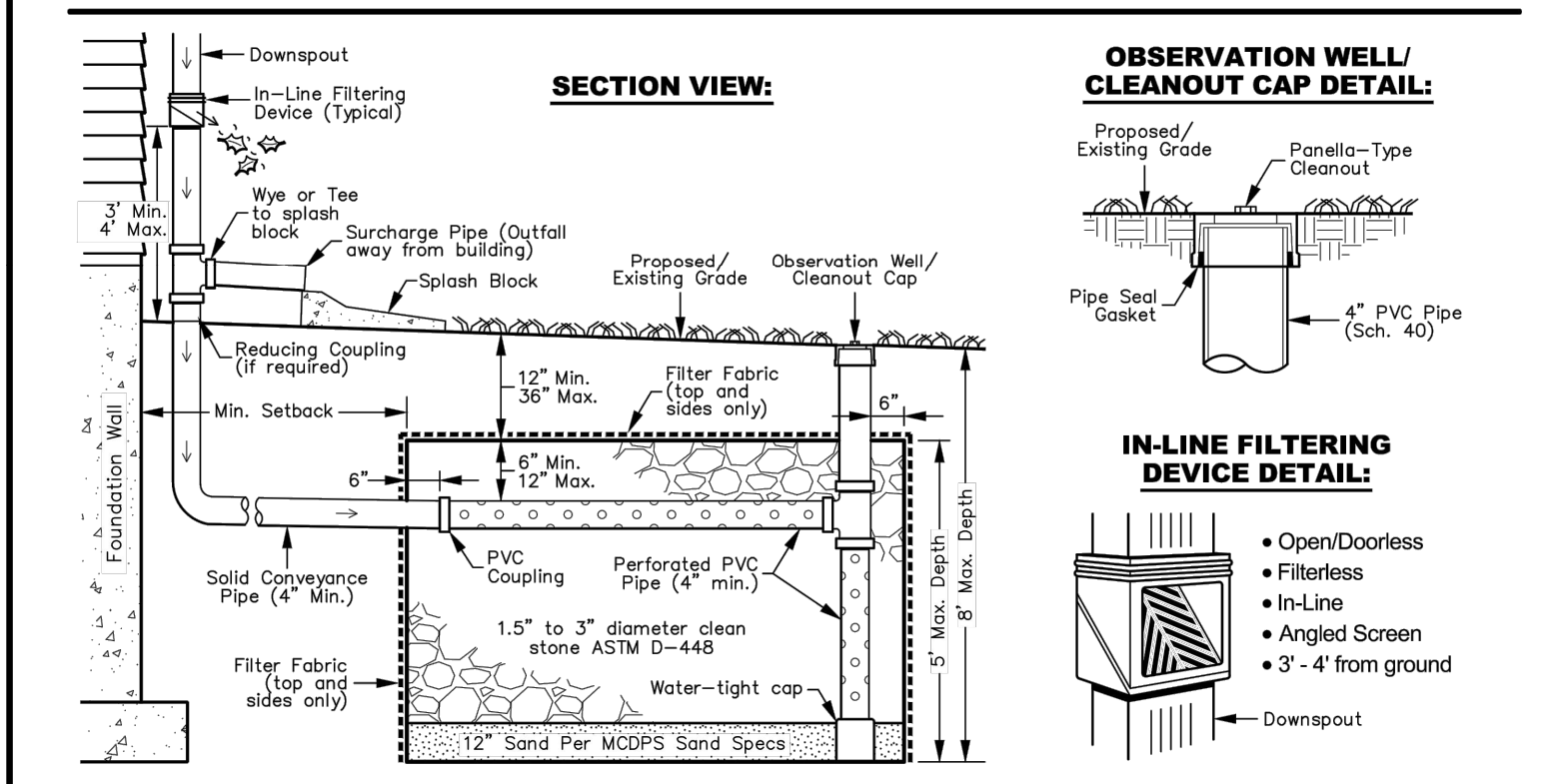

MONTGOMERY COUNTY DEPARTMENT OF PERMITTING SERVICES
 WATER RESOURCES SECTION

DRY WELL FOR ROOF RUNOFF DETAIL

DATE: SEPTEMBER 2021
 SCALE: NONE

Linda Kobylski, Land Development Division Chief

September 1, 2021

INOVA Engineering Consultants, Inc
 (Engineers, Surveyors, Land Development)
 25209 Larks Terrace
 South Riding, Virginia 20152
 Phone : (703) 655-3951
 E-mail: info@inovaeengineers.com

SITE PLAN SHOWING PROPOSED ADDITION KENSINGTON PARK LOT 8, BLOCK 9 10305 ARMORY AVENUE, KENSINGTON MONTGOMERY COUNTY, MARYLAND 20895

NO.	DATE	BY	REVISION

ACC NO: 012022560
 DESIGN BY: RLP
 DRAWN BY:
 CHECKED BY:
 DATE: 6-15-2024
 SCALE: 1"=10'
 SHEET : 2 OF 2

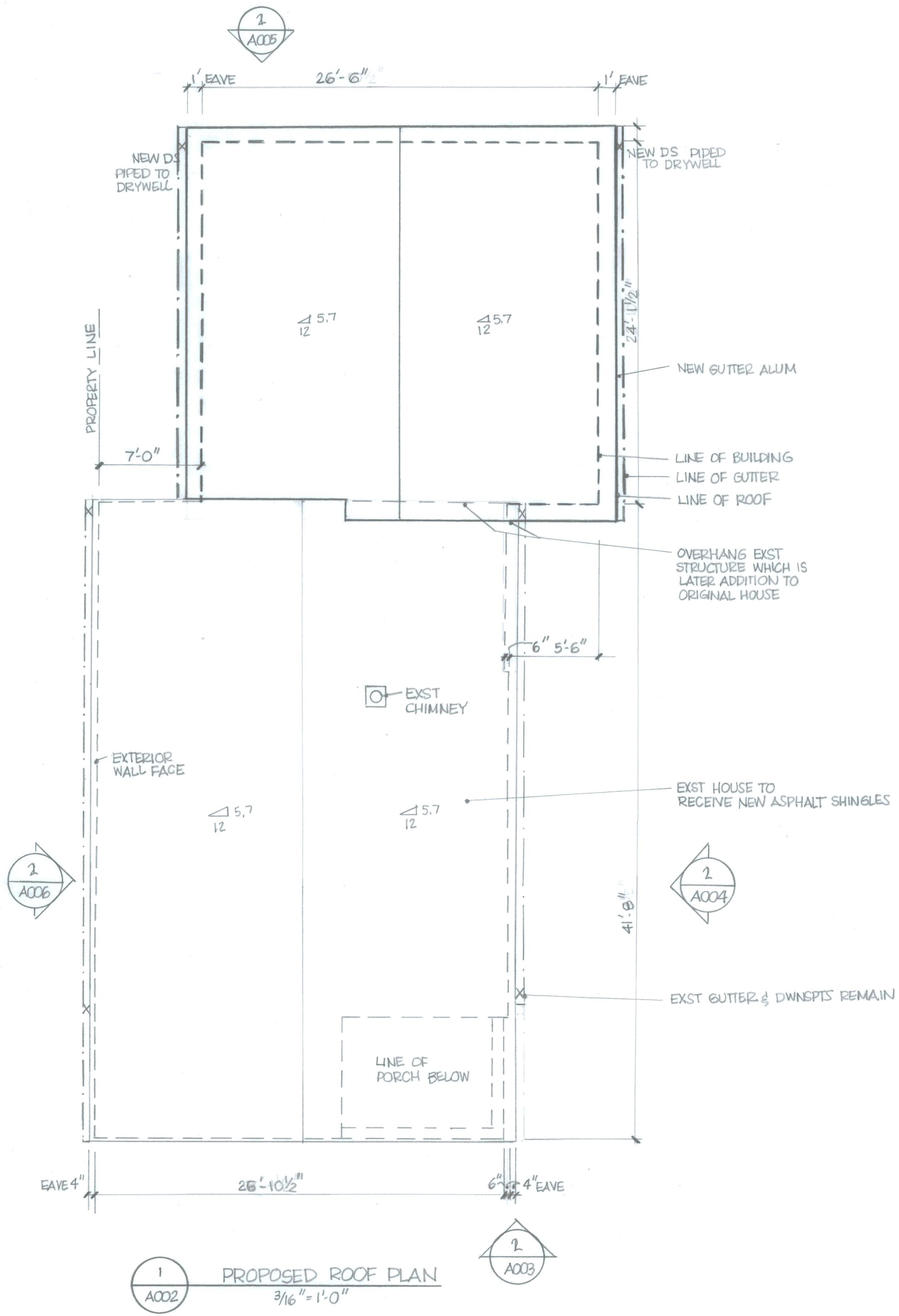

1
 A002
PROPOSED ROOF PLAN
 3/16" = 1'-0"

ED WESELY 703 370 5406
 10305 ARMORY AVE
 KENSINGTON MD 20895
 6-18-24 A002

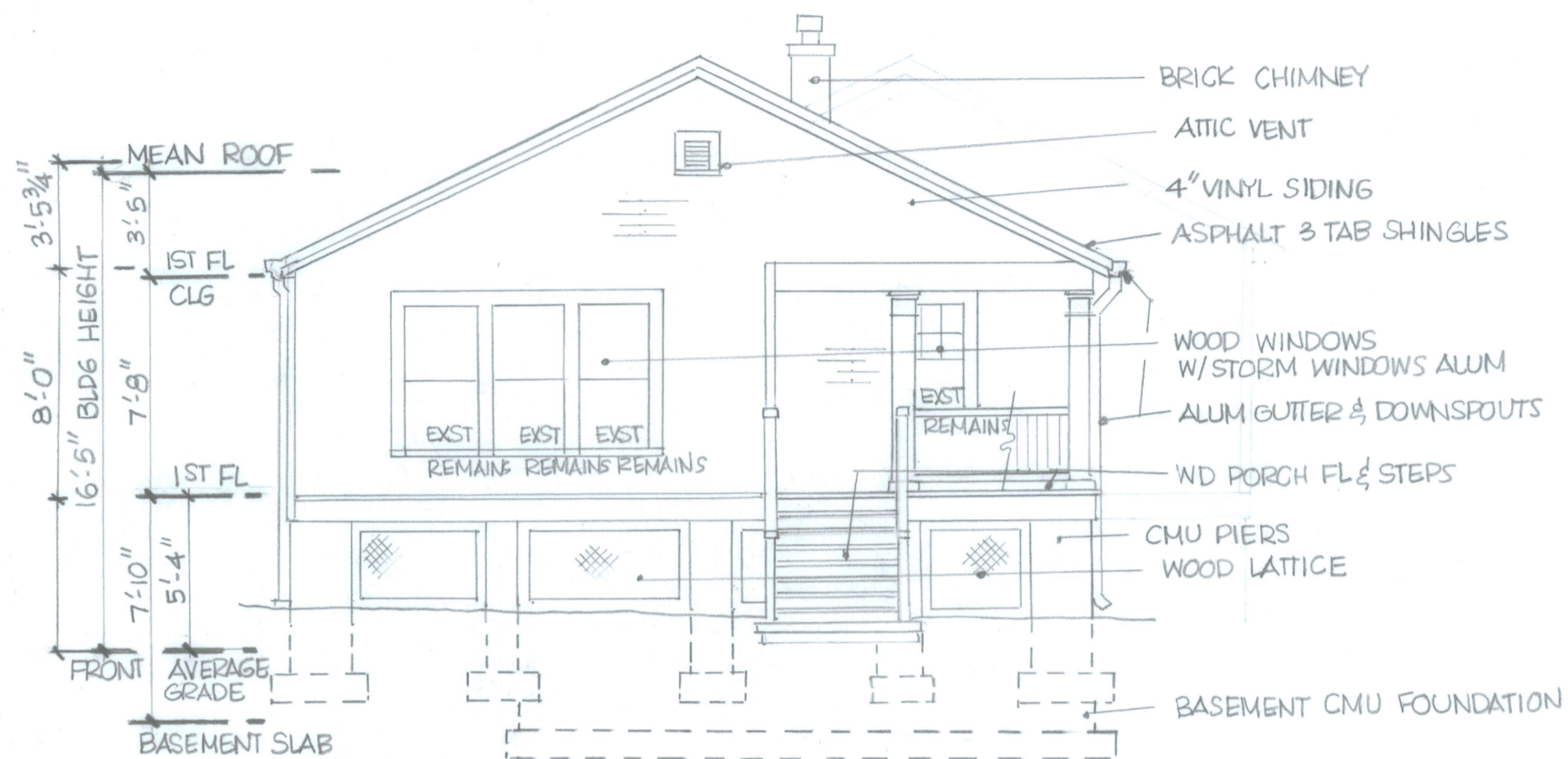

1 EXST FRONT ELEVATION
A003 3/16" = 1'-0"

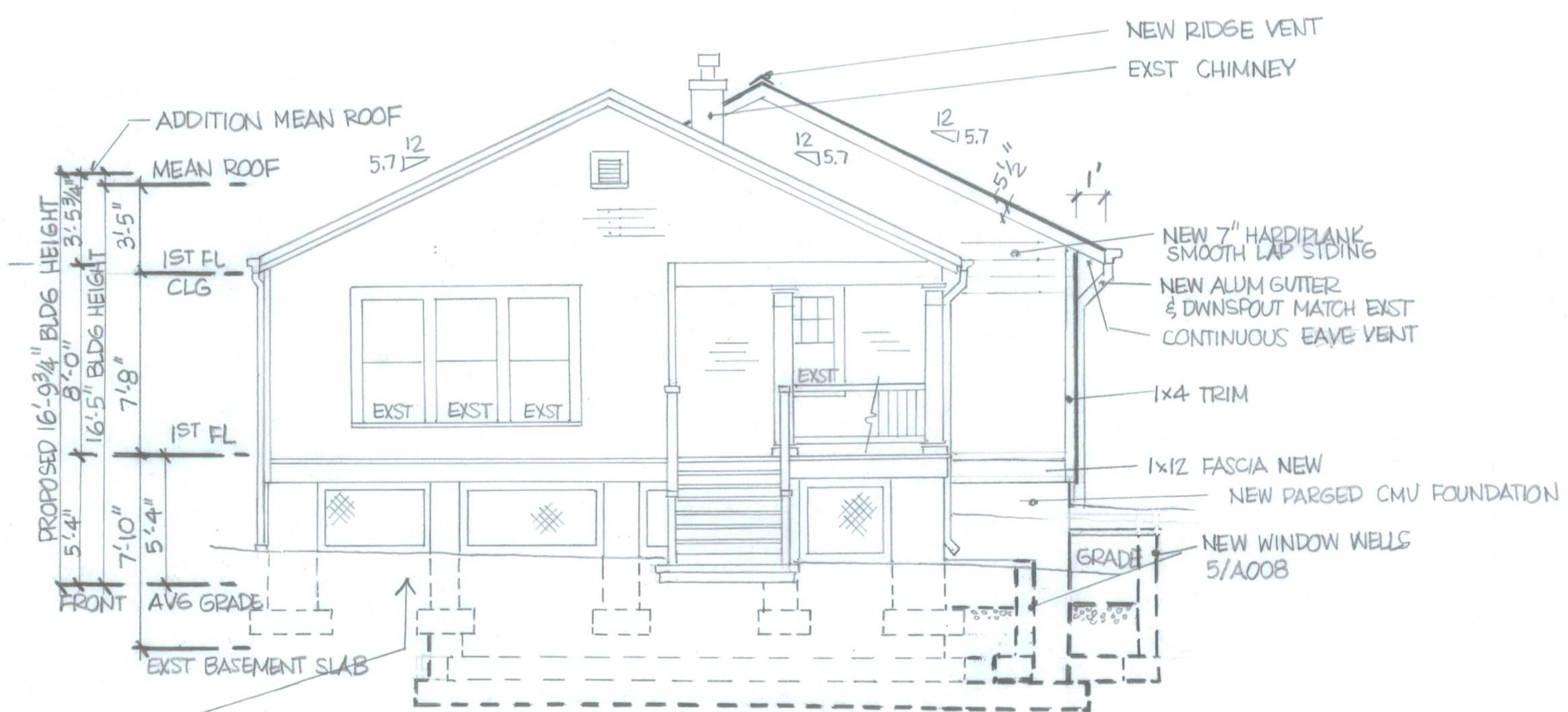

2 PROPOSED FRONT ELEVATION
A003 3/16" = 1'-0"

ENTIRE FRONT FACADE OF EXST HOUSE IS MAINTAINED AS EXST

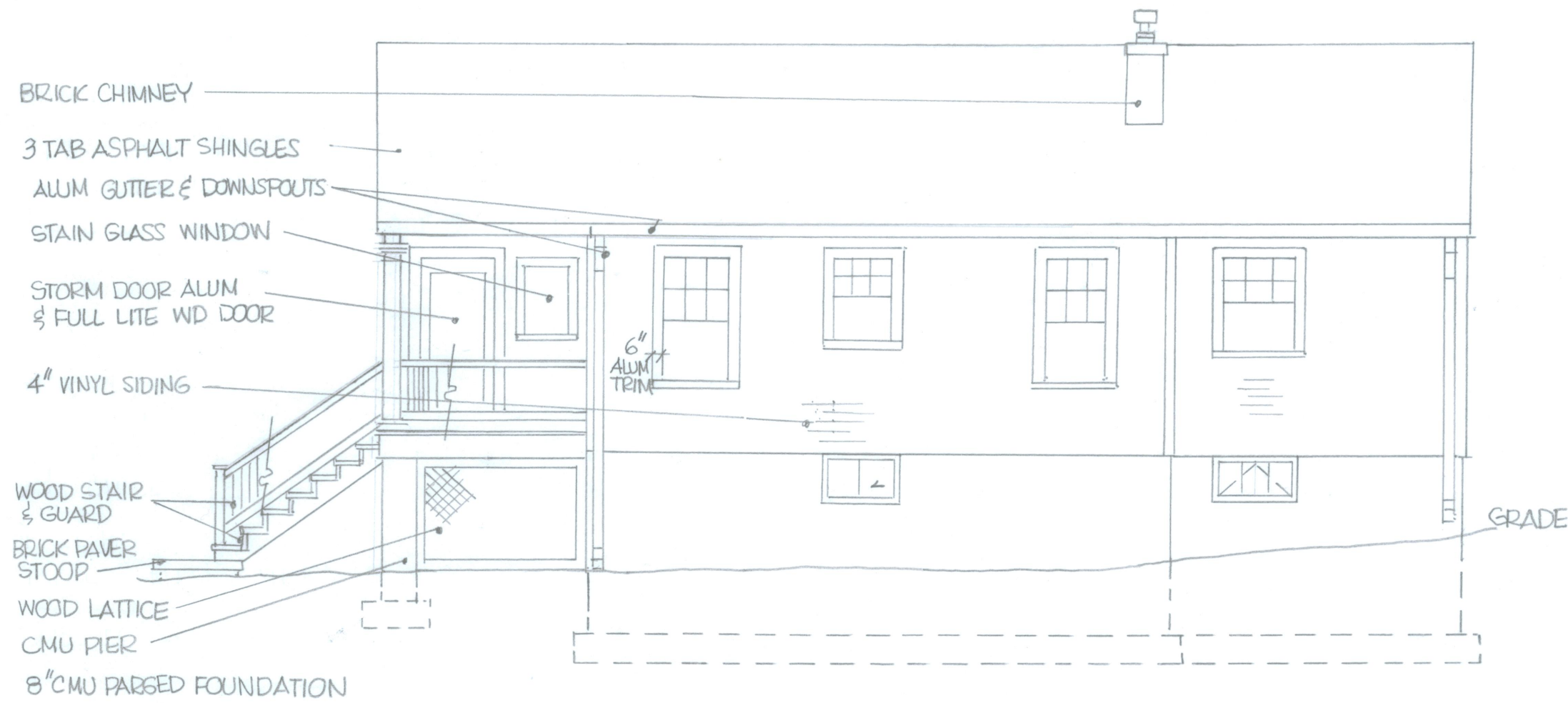

1 EXST SIDE ELEVATION
A004 3/16"=1'-0"

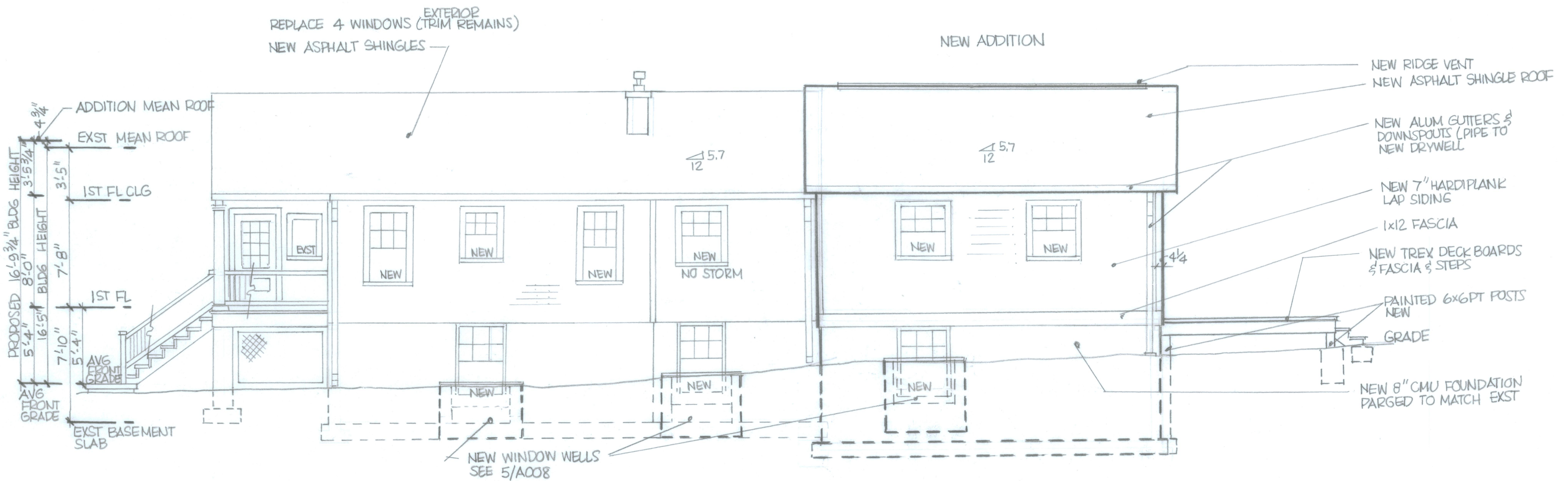

2 PROPOSED SIDE ELEVATION
A004 3/16"=1'-0"

EXISTING HOUSE FINISHES THIS SIDE REMAIN INTACT WITH THE FOLLOWING EXCEPTIONS

1. POSSIBLE NEW FRONT DOOR
2. REPLACE (4) 1ST FL WINDOWS
3. ENLARGE (2) BASEMENT WINDOWS & NEW EGRESS WELLS
4. REPLACE ROOF SHINGLE

ED WESELY 703 370 5406

10305 ARMORY AVE
KENSINGTON MD 20895

6-18-24

A004

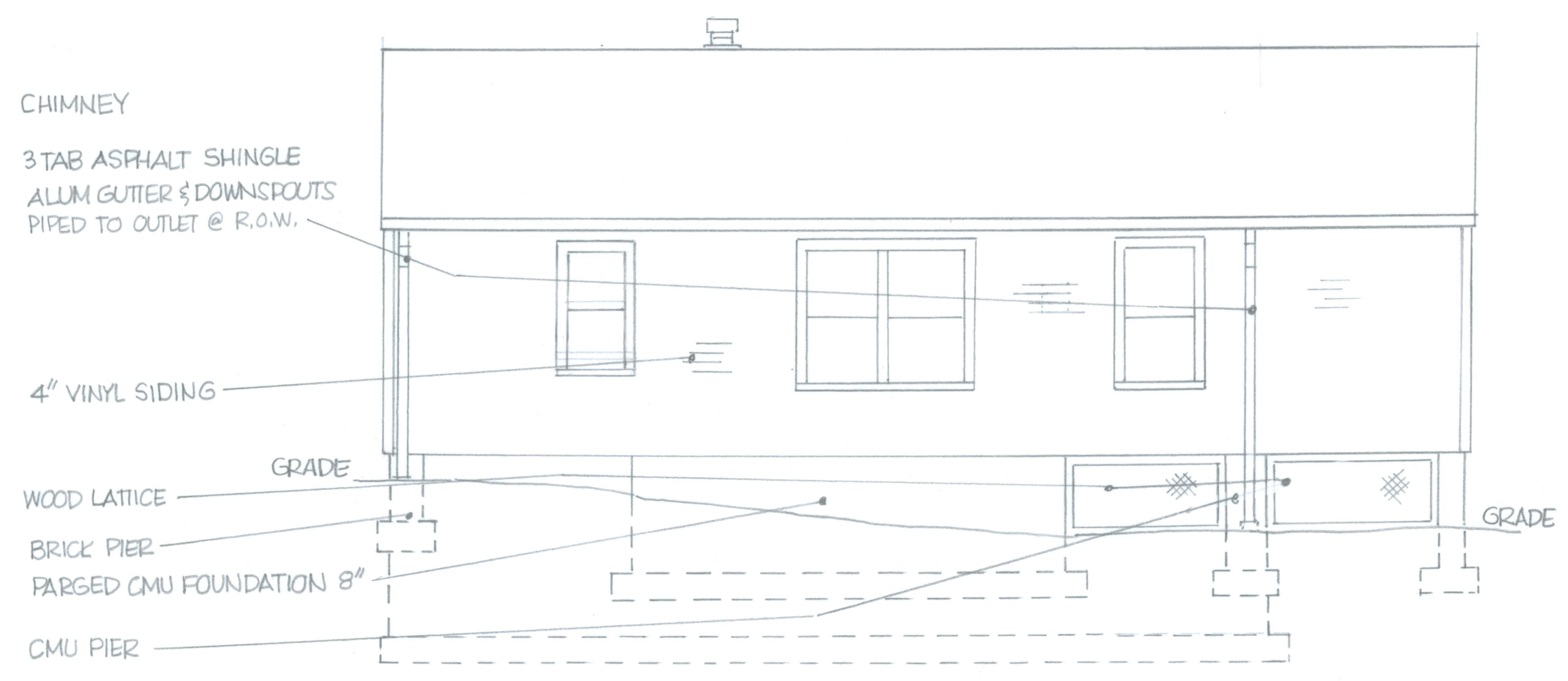

1 EXST SIDE ELEVATION
 3/16" = 1'-0"

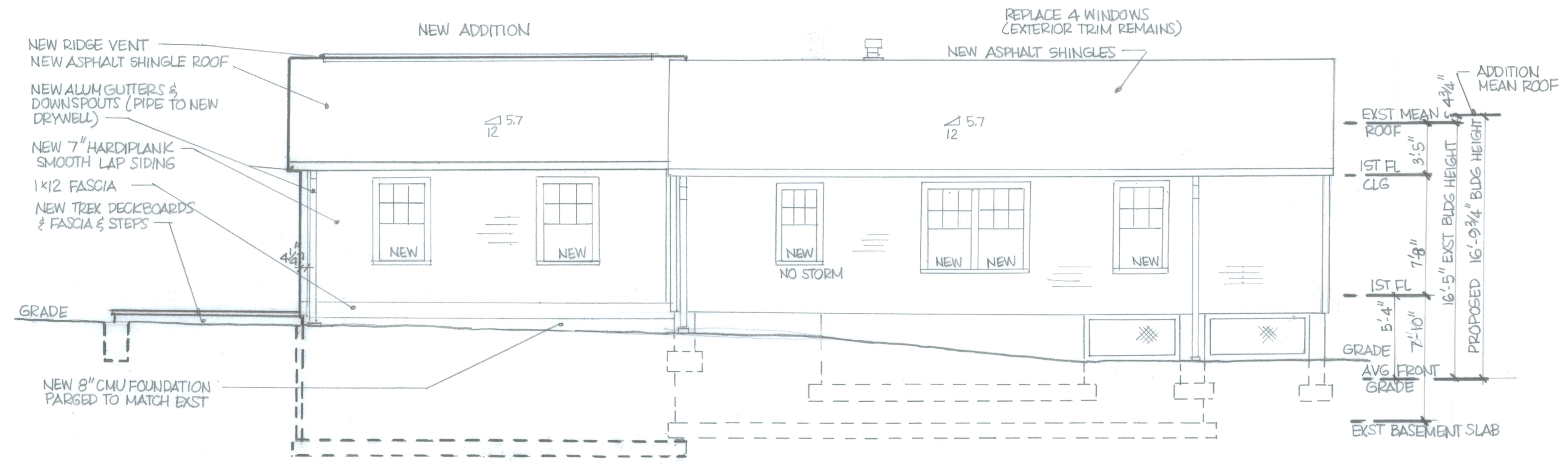

2 PROPOSED SIDE ELEVATION
 3/16" = 1'-0"

EXISTING HOUSE FINISHES
 THIS SIDE REMAIN INTACT WITH
 THE FOLLOWING EXCEPTIONS

1. REPLACE (4) 1ST FL WINDOWS
2. REPLACE ROOF SHINGLES

EXTERIOR DOOR & WINDOW SCHEDULE

MARK	QTY	LOCATION	SIZE	TYPE	REMARKS	EXST STORM REMAINS	
△	1	3	LIVING	28" x 61"	WOOD DH 1 OVER 1 LITE	LATER WINDOW WHEN PORCH ENCL	*
△	2	1	LIVING	24" x 35"	WOOD FIXED STAIN GL		
△	3	1	BEDRM 1	29" x 56"	WOOD DH 6 OVER 1 LITE	ORIGINAL	*
	4	1	BEDRM 1	33" x 56"	NEW WOOD DH 6 OVER 1	ORIGINAL	*
	5	1	BEDRM 1	29" x 37"	NEW WOOD DH 6 OVER 1	ORIGINAL	*
	6	1	BEDRM 2	29" x 56"	NEW WOOD DH 6 OVER 1	ORIGINAL	*
	7	1	BEDRM 2	29" x 45"	NEW WOOD DH 6 OVER 1	COMPOSITE	*
	8	1	LIVING	30" x 61"	NEW WOOD DH 6 OVER 1	ORIGINAL	*
	9	2	DEN	31" x 61"	NEW WOOD DH 6 OVER 1		*
	10	1	BATH	25" x 56"	NEW WOOD DH 6 OVER 1	COMPOSITE	
△	11	1	PANTRY	42" x 16"	EXST WOOD AWNING	LATER ADDITION	
	12	4	FAMILY	36" x 60"	NEW WOOD DH 6 OVER 1	NEW ADDITION	
	13	2	KITCHEN	36" x 42"	NEW WOOD DH 6 OVER 1	NEW ADDITION	
	14	2	BASEMENT	36" x 60"	NEW WOOD DH 6 OVER 1	ONE COMP. ONE METAL NEITHER ORIG	

* EXST STORM REMAINS
 △ EXST WINDOWS REMAIN (CAN EASILY BE REPAIRED)

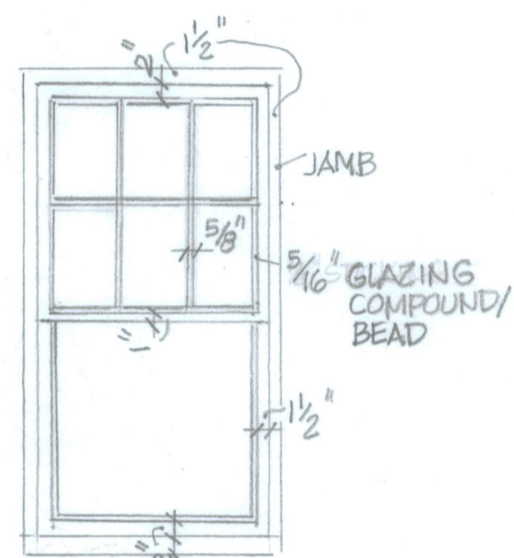

EXTERIOR EXST ELEV ORIGINAL WINDOW WOOD

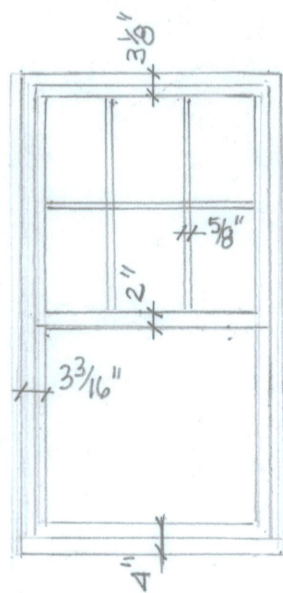

PROPOSED NEW WOOD WINDOW ELEV
 NO BEAD & HORIZONTAL MID RAIL IS 2" INSTEAD OF 1"
 5/8" PUTTY RATHER THAN TRADITION STOPS OF ORIGINAL (FRONT LIVING HAS PUTTY STOPS)

NOTE STORM WINDOW FRAMES COVER 3" OF SHOWN WINDOWS EA SIDE

NEW ADDITION WINDOWS TO TRIM WITH 5 1/2" FLAT CASING & 2 1/2" SILL
 BASEMENT WINDOWS TO RECEIVE 2" FLAT CASING AS BRICK MOLD

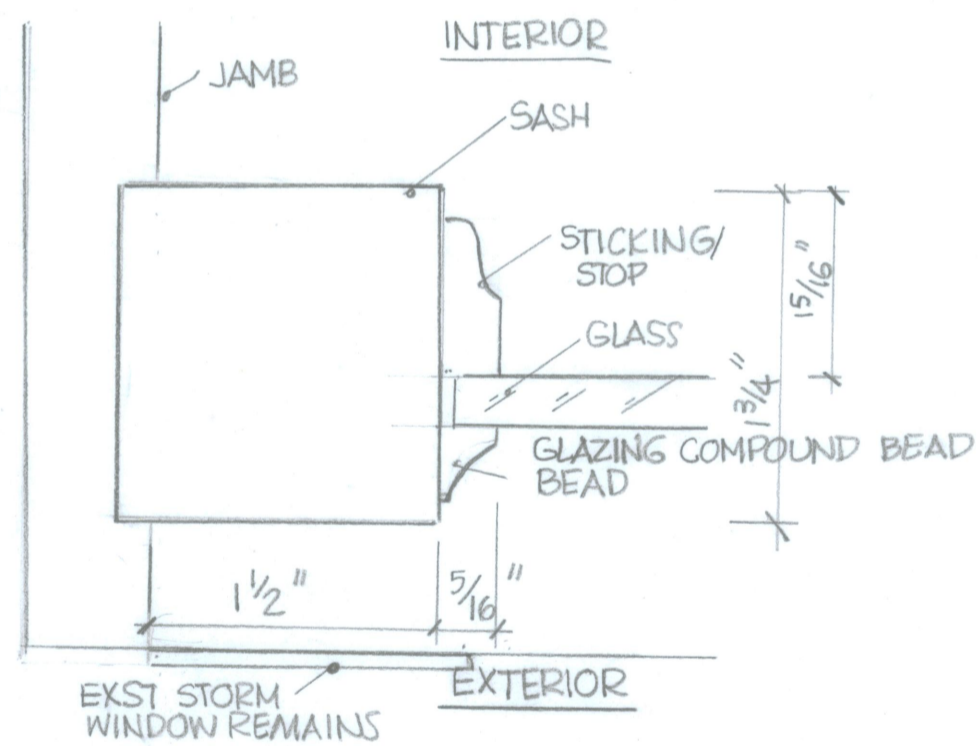

1 WINDOW RAIL SECTION EXST ORIGINAL WINDOW FULL SCALE A008

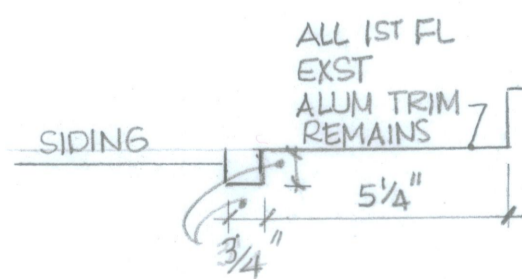

2 WINDOW DETAILS A008

ALL 1ST FL EXST ALUM TRIM REMAINS
 PROPOSED EXTERIOR WD CASING @ ADDITION

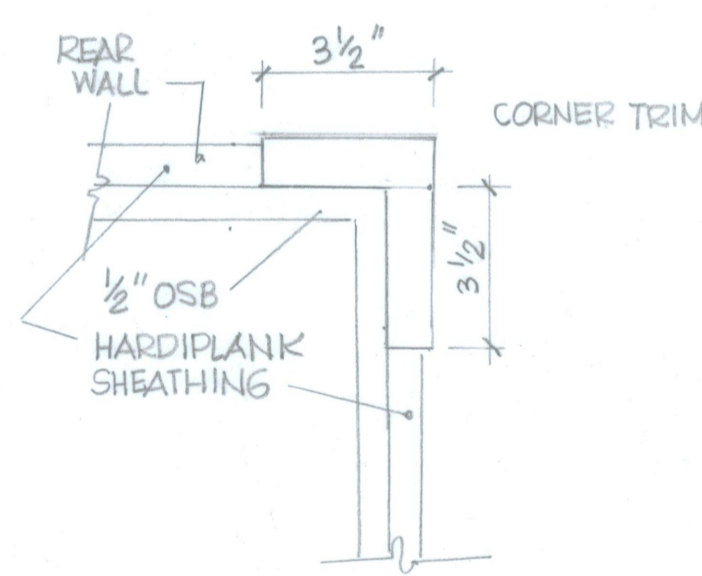

3 ADDITION OUTSIDE CORNER 3" = 1'-0" A008

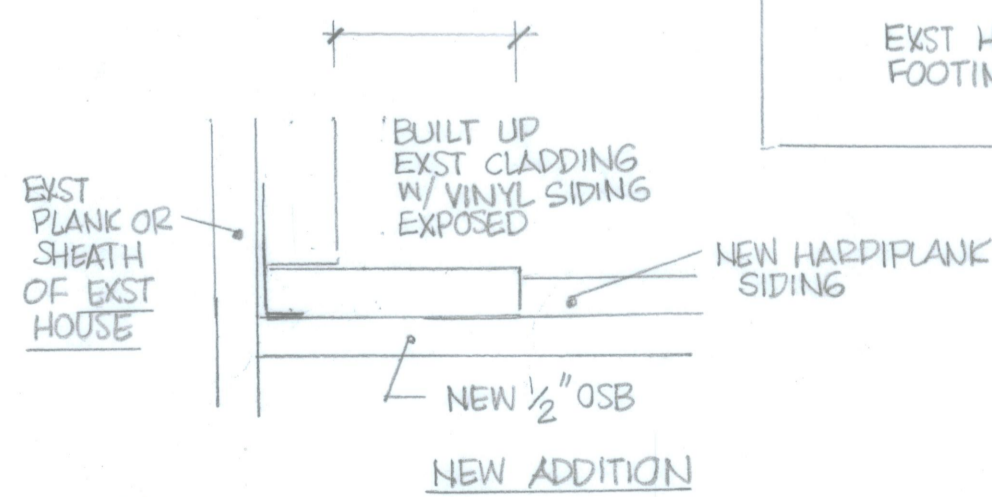

4 ADDITION INSIDE CORNER 3" = 1'-0" A008

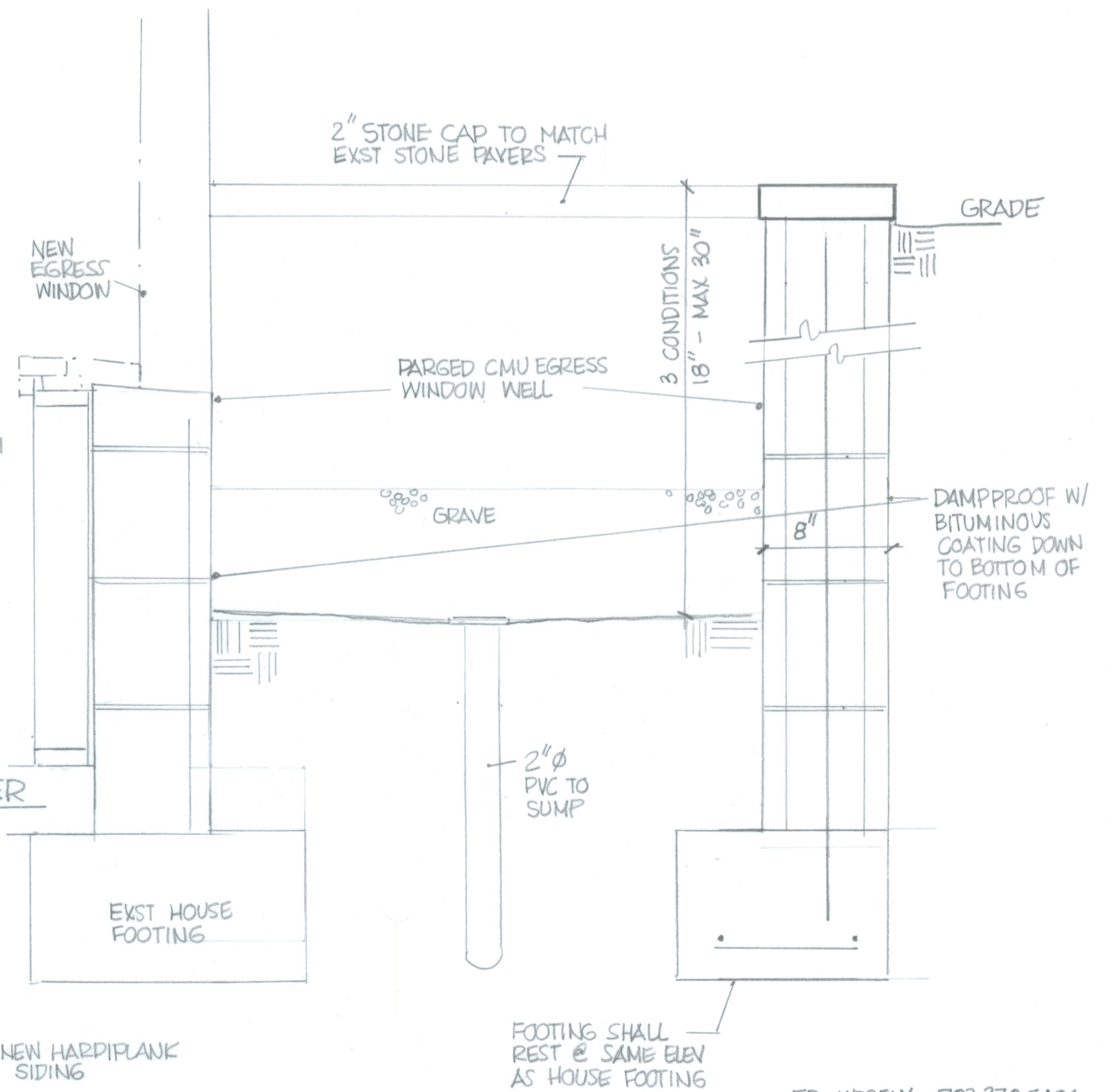

5 EGRESS WELL DETAIL 1 1/2" = 1'-0" A008

ED WESELY 703 370 5406

10305 ARMORY AVE
 KENSINGTON, MD 20895

6-18-24 A008