

MONTGOMERY COUNTY HISTORIC PRESERVATION COMMISSION
STAFF REPORT

Address:	45 West Lenox Street, Chevy Chase	Meeting Date:	6/28/2023
Resource:	Contributing Resource Chevy Chase Village Historic District	Report Date:	6/21/2023
Applicant:	Susan Gorman (Agent, MMD Construction)	Public Notice:	6/14/2023
Review:	HAWP	Tax Credit:	No
		Staff:	John Liebertz

Permit Number: 1029893

PROPOSAL: Window and door replacement.

STAFF RECOMMENDATION

Staff recommends that the Historic Preservation Commission (HPC) **approve with one (1) condition** the HAWP application with final approval delegated to staff:

1. The applicant shall submit an updated specification for Window #3. The new aluminum-clad window shall match the design of the existing six-over-six, round arched window. This includes the form and the muntin pattern.

ARCHITECTURAL DESCRIPTION

SIGNIFICANCE: Contributing Resource within the Chevy Chase Village Historic District
STYLE: Colonial Revival
DATE: 1916-1924

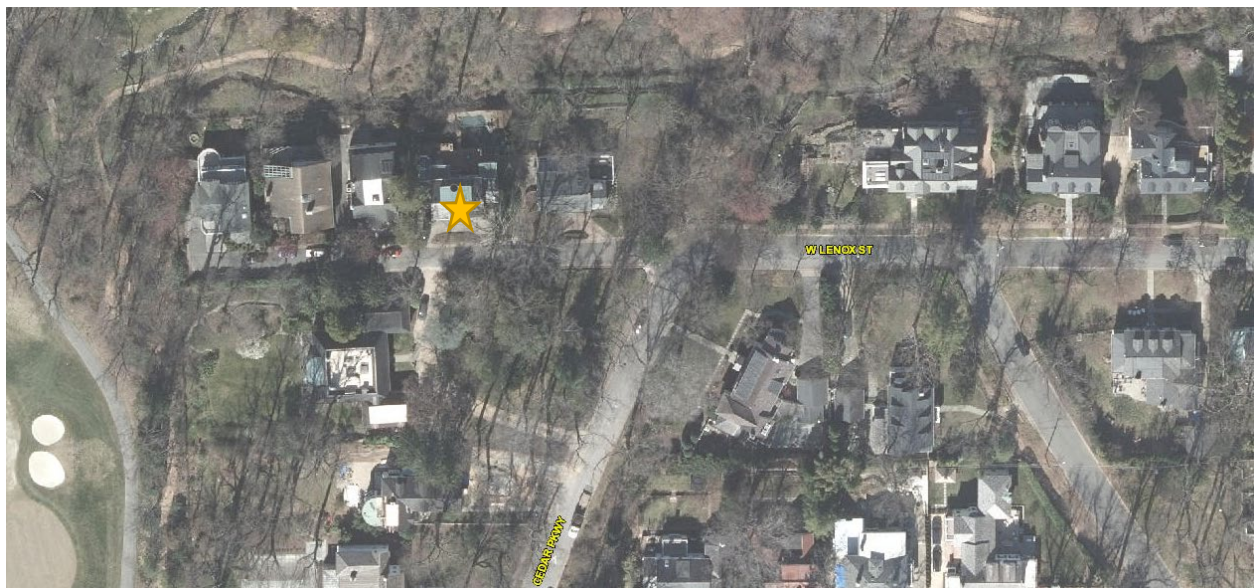

Figure 1: The subject property at 45 West Lenox Street is located mid-block on the northern side of the road. The yellow star is the subject property. Source: Montgomery Planning.

PROPOSAL

The applicant proposes the following work: 1) remove all the original wood and non-historic, aluminum-clad, wood windows; 2) install aluminum-clad, simulated divided light, wood windows that match the fenestration pattern and design of the existing windows; and 3) replace two doors on the side and rear elevations of the house with single-light, aluminum-clad, wood doors. The existing window trim and shutters would remain intact.

APPLICABLE GUIDELINES

The Historic Preservation Office and Historic Preservation Commission (HPC) consult several documents when reviewing alterations and new construction within the Chevy Chase Village Historic District. These documents include the historic preservation review guidelines in the approved and adopted amendment for the *Chevy Chase Historic District (Guidelines)*, *Montgomery County Code Chapter 24A (Chapter 24A)*, and *the Secretary of the Interior's Standards for Rehabilitation (Standards)*. The pertinent information in these three documents is outlined below.

Chevy Chase Village Historic District Guidelines

The *Guidelines* break down specific projects into three levels of review - Lenient, Moderate and Strict Scrutiny.

“Lenient Scrutiny” means that the emphasis of the review should be on issues of general massing and scale, and compatibility with the surrounding streetscape, and should allow for a very liberal interpretation of preservation rules. Most changes should be permitted unless there are major problems with massing, scale or compatibility.

“Moderate Scrutiny” involves a higher standard of review than “lenient scrutiny.” Besides issues of massing, scale and compatibility, preserving the integrity of the resource is taken into account. Alterations should be designed so that the altered structure still contributes to the district. Use of compatible new materials, rather than the original building materials, should be permitted. Planned changes should be compatible with the structure’s existing design, but should not be required to replicate its architectural style.

“Strict Scrutiny” means that the planned changes should be reviewed to insure that the integrity of the significant exterior architectural or landscaping features and details is not compromised. However, strict scrutiny should not be “strict in theory but fatal in fact” i.e. it does not mean that there can be no changes but simply that the proposed changes should be reviewed with extra care.

The *Guidelines* state five basic policies that should be adhered to, including:

- Preserving the integrity of the Chevy Chase Village Historic District. Any alterations should at a minimum, perpetuate the ability to perceive the sense of time and place portrayed by the district.
- Preserving the integrity of contributing structures. Alterations should be designed in such a way that the altered structure still contributes to the district.
- Maintaining the variety of architectural styles and the tradition of architectural excellence.
- Design review emphasis should be restricted to changes that will be visible from the front or side public right-of-way, or that would be visible in the absence of vegetation or landscaping.
- Alterations to the portion of a property that are not visible from the public-right-of-way should be subject to a very lenient review. Most changes to the rear of the properties should be approved as a matter of course.

The *Guidelines* that pertain to this project are as follows:

- Doors should be subject to moderate scrutiny if they are visible from the public right-of-way, lenient scrutiny if they are not. For outstanding resources, they should be subject to strict scrutiny if they are visible from the public right-of-way. Addition of compatible storm doors should be encouraged.
- Windows (including window replacement) should be subject to moderate scrutiny if they are visible from the public right-of-way, lenient scrutiny if they are not. For outstanding resources, they should be subject to strict scrutiny. Addition of compatible exterior storm windows should be encouraged, whether visible from the public right-of-way or not. Vinyl and aluminum windows (other than storm windows) should be discouraged. Addition of security bars should be subject to lenient scrutiny. whether visible from the public right-of-way or not.

Montgomery County Code, Chapter 24A-8

The following guidance which pertains to this project are as follows:

- (b) The commission shall instruct the director to issue a permit, or issue a permit subject to such conditions as are found to be necessary to ensure conformity with the purposes and requirements of this chapter, if it finds that:
 - (1) The proposal will not substantially alter the exterior features of an historic site or historic resource within an historic district; or
 - (2) The proposal is compatible in character and nature with the historical, archeological, architectural or cultural features of the historic site or the historic district in which an historic resource is located and would not be detrimental thereto or to the achievement of the purposes of this chapter;
- (d) In the case of an application for work on an historic resource located within an historic district, the commission shall be lenient in its judgment of plans for structures of little historical or design significance or for plans involving new construction, unless such plans would seriously impair the historic or architectural value of surrounding historic resources or would impair the character of the historic district. (Ord. No. 9-4, § 1; Ord. No. 11-59.)

Secretary of the Interior’s Standards for Rehabilitation

The Secretary of the Interior defines rehabilitation as “the act or process of making possible a compatible use for a property through repair, alterations, and additions while preserving those portions or features, which convey its historical, cultural, or architectural values.” The applicable *Standards* are as follows:

- 2. The historic character of a property shall be retained and preserved. The removal of historic materials or alteration of features and spaces that characterize a property shall be avoided.
- 9. New additions, exterior alterations, or related new construction shall not destroy historic materials that characterize the property. The new work shall be differentiated from the old and shall be compatible with the massing, size, scale, and architectural features to protect the historic integrity of the property and its environment.
- 10. New additions and adjacent or related new construction shall be undertaken in such a manner that if removed in the future, the essential form and integrity of the historic property and its environment would be unimpaired.

STAFF DISCUSSION

The subject property is Contributing Resource in the Chevy Chase Village Historic District. The Colonial Revival, wood-frame house was constructed between 1916 and 1924. Historic Area Work Permits (HAWPS) approved by the HPC include the construction of a one-story, hexagonal bay on the rear of the house in 2000 and replacement of the front portico and alteration to a number of windows on the rear and side elevations.¹



Figure 2: View of the façade of 45 West Lenox Street, 2023. Source: Montgomery Planning.

Replacement of Windows

Staff finds that the replacement of the historic and non-historic windows (except for Windows #3, #31, and #32 – see section below) to be consistent with the applicable guidelines and recommends approval. Staff reviewed the replacement of the windows with “moderate scrutiny” per the guidelines which permits the use of “new compatible materials.” While the guidelines discourage the installation of “vinyl and aluminum windows,” aluminum-clad wood windows are a superior product than the referenced “aluminum windows” and should not be considered in a similar light. The replacement of the original wood windows with simulated divided light, aluminum-clad, wood-sash windows would diminish the historic integrity (materials, design, and workmanship) of the contributing resource but not to the extent that it would change the property’s classification to non-contributing. The proposed windows would

¹ For more information see, https://mcatlas.org/tiles/06_HistoricPreservation_PhotoArchives/Padlock/HAR60640002/Box009/35-13-00R_Chevy%20Chase%20Village%20HD-Phase%201_45%20West%20Lenox%20Street_06-26-2000.pdf and https://mcatlas.org/tiles/06_HistoricPreservation_PhotoArchives/Padlock/HAR60640007/Box059/35-13-04Q_Chevy%20Chase%20Historic%20District_45%20West%20Lenox%20St_06-09-2004.pdf.

retain the existing fenestration pattern, size of the opening, and design of the windows. Therefore, the windows would be compatible with the architectural features of the site and historic district. In a similar case, the Board of Appeals of Montgomery County found that the HPC incorrectly denied an applicant's request to replace original wood windows with similar aluminum-clad wood windows at 22 Hesketh Street—a Contributing Resource in the Chevy Chase Historic District—in 2013.²

Replacement of Windows #31 and #32

Staff finds that the replacement of the rear, non-historic to be consistent with the applicable guidelines and recommends approval. Staff reviewed the replacement of the windows with “lenient scrutiny” per the guidelines. The non-historic windows were installed as part of the 2004 approved HAWP. Alteration of the fenestration pattern from an eight-over-one, simulated divided light window to an eight-over-eight, simulated divided light, aluminum-clad, wood window would have no adverse effect on the individual resource or streetscape and should be approved as a matter of course.

Replacement of Window #3

Staff finds that the replacement of the double-hung, six-over-six, rounded arched, wood window to be consistent with the applicable guidelines and recommends approval with conditions. Staff reviewed the replacement of the window with “moderate scrutiny” per the guidelines. The original window is a character defining feature and highly-visible element on the facade of the contributing resource. While the replacement of the wood window with an aluminum-clad wood window should be permitted as justified earlier in the staff report, the alteration of the design of the window should be avoided due to the adverse effect to the individual resource and the character of the district. The proposal remains unclear regarding the replacement of this window as shown in *Figure 3*. The applicant's specification depicts a rectangular window with a singular, round-arched light in the upper sash and a singular, rectangular-light in the lower sash. Staff recommends that the applicant retain the existing design of the round arched window (including the muntin pattern). Please see *Figure 4* for an example of a half-circle, double-hung, aluminum-clad, wood window from the same series/manufacturer. The window, however, should be custom-made to match the muntin pattern of the existing window.



Figure 3: View of the façade of 45 West Lenox Street, 2023 (left), close-up view of Window #3 (middle), and applicant's proposed replacement specification labeled as “ultra rectangular out – half circle in double hung” (right). Source: Montgomery Planning and Applicant.

² Board of Appeals of Montgomery County, Case No. A-6402, Appeal of Margaret S. Marcus, May 8, 2013. For more information, <https://mcatlas.org/filetransfer/HistoricPreservation/Temp%20Files/22%20Hesketh%20Street.%20Chevy%20Chase%20Appeal%20-%20A-6402%20Decision.pdf>.

Half-Circle Top Sterling Double Hungs

F.S.	1'-9 1/2"	2'-1 1/2"	2'-5 1/2"	2'-7 1/2"	2'-9 1/2"	2'-11 1/2"	3'-1 1/2"	3'-5 1/2"	3'-9 1/2"
R.O.	1'-10"	2'-2"	2'-6"	2'-8"	2'-10"	3'-0"	3'-2"	3'-6"	3'-10"
S.O.	1'-8"	2'-0"	2'-4"	2'-6"	2'-8"	2'-10"	3'-0"	3'-4"	3'-8"
G.S.	16"	20"	24"	26"	28"	30"	32"	36"	40"











3'-0 1/2"						
3'-1 1/16"	1614-HC	2014-HC	2414-HC	2614-HC	2816-HC	3016-HC
2'-10"						
14"						
3'-4 1/2"						
3'-5 1/16"	1616-HC	2016-HC	2416-HC	2616-HC		
3'-2"						
16"						

Figure 4: Staff recommends the applicant retain the existing window design. Here is an example of a half-circle (or round arched), double-hung window (circled in red) available from Kolbie Windows. The applicant would need to have a custom-designed window manufactured that matches the existing muntin pattern. Source: Kolbie Windows.

Replacement of Doors #9 and #22

Staff finds that the replacement of the doors to be consistent with the applicable guidelines and recommends approval. Staff reviewed the replacement of the doors with “lenient scrutiny” per the guidelines. The doors are not visible from the public rights-of-way and their replacement would have no adverse effect to the individual resource or the massing, scale, or compatibility with the streetscape.

After full and fair consideration of the applicant’s submission, staff finds the proposal, as modified by the conditions, consistent with the Criteria for Issuance in Chapter 24A-8(b)(1), (2) and (d), having found the proposal is consistent with the *Secretary of the Interior’s Standards for Rehabilitation #2, #9, and #10*, and *Chevy Chase Village Historic District Guidelines* outlined above.

STAFF RECOMMENDATION

Staff recommends that the Historic Preservation Commission (HPC) **approve with one (1) condition** the HAWP:

1. The applicant shall submit an updated specification for Window #3. The new aluminum-clad window shall match the design of the existing six-over-six, round arched window. This includes the form and the muntin pattern.

under the Criteria for Issuance in Chapter 24A-8(b), (1), (2), and (d), having found that the proposal is consistent with the *Chevy Chase Village Historic District Guidelines*, and therefore will not substantially alter the exterior features of the historic resource and is compatible in character with the district and the purposes of Chapter 24A;

and with the general condition that the applicant shall present an electronic set of drawings, if applicable, to Historic Preservation Commission (HPC) staff for review and stamping prior to submission for the Montgomery County Department of Permitting Services (DPS) building permits;

and with the general condition that final project design details, not specifically delineated by the Commission, shall be approved by HPC staff or brought back to the Commission as a revised HAWP application at staff’s discretion;

and with the general condition that the applicant shall notify the Historic Preservation Staff if they propose to make any alterations to the approved plans. Once the work is completed the applicant will contact the staff person assigned to this application at 301-563-3400 or john.liebertz@montgomeryplanning.org to schedule a follow-up site visit.

45 W LENOX HAWP APPLICATION

Homeowner: Gorman

**MMD CONSTRUCTION
202-731-1177**

**EACH numbered window is being replaced all others are remaining as is
this document goes in numerical order consisting of 4 with a few
exeptions pages each, sketch, details sheet (2 pageswith a few exeptions),
and a specs sheet**

at the bottom there are drawings of the storm details and mullions details

CURRENT STORMS WILL BE REMOVED WINDOW TRIM/ SHUTTERS WILL REMAIN AS EXISTING

**X's through half pages are just not apart of that window series and will be referenced in another part of t
doc**

8/8 is intentional for the rear back closet windows

we did did changed the mullions from 7/8 back to 5/8



**APPLICATION FOR
HISTORIC AREA WORK PERMIT**
HISTORIC PRESERVATION COMMISSION
301.563.3400

FOR STAFF ONLY:
HAWP# _____
DATE ASSIGNED _____

APPLICANT:

Name: Susan Gorman
Address: 45 W Lenox
Daytime Phone: 301-706-2215

E-mail: ssgchch@aol.com
City: Chevy Chase Zip: 20815
Tax Account No.: _____

AGENT/CONTACT (if applicable):

Name: MMD Construction
Address: 3724 Northampton
Daytime Phone: 202-731-1177

E-mail: michele@mmdconstruction.com
City: Washington Zip: 20015
Contractor Registration No.: 146756

LOCATION OF BUILDING/PREMISE: MIHP # of Historic Property 35/13

Is the Property Located within an Historic District? X Yes/District Name Chevy Chase
 No/Individual Site Name _____

Is there an Historic Preservation/Land Trust/Environmental Easement on the Property? If YES, include a map of the easement, and documentation from the Easement Holder supporting this application.

Are other Planning and/or Hearing Examiner Approvals /Reviews Required as part of this Application? (Conditional Use, Variance, Record Plat, etc.?) If YES, include information on these reviews as supplemental information.

Building Number: 45 Street: W Lenox
Town/City: Chevy Chase Nearest Cross Street: Cedar PKWY
Lot: 4097 Block: _____ Subdivision: 0009 Parcel: p954

TYPE OF WORK PROPOSED: See the checklist on Page 4 to verify that all supporting items for proposed work are submitted with this application. Incomplete Applications will not be accepted for review. Check all that apply:

- | | | |
|---|--|--|
| <input type="checkbox"/> New Construction | <input type="checkbox"/> Deck/Porch | <input type="checkbox"/> Shed/Garage/Accessory Structure |
| <input type="checkbox"/> Addition | <input type="checkbox"/> Fence | <input type="checkbox"/> Solar |
| <input type="checkbox"/> Demolition | <input type="checkbox"/> Hardscape/Landscape | <input type="checkbox"/> Tree removal/planting |
| <input type="checkbox"/> Grading/Excavation | <input type="checkbox"/> Roof | <input checked="" type="checkbox"/> Window/Door |
| | | <input type="checkbox"/> Other: _____ |

I hereby certify that I have the authority to make the foregoing application, that the application is correct and accurate and that the construction will comply with plans reviewed and approved by all necessary agencies and hereby acknowledge and accept this to be a condition for the issuance of this permit.

Signature of owner or authorized agent

5-9-23
Date

HAWP APPLICATION: MAILING ADDRESSES FOR NOTIFYING
[Owner, Owner's Agent, Adjacent and Confronting Property Owners]

Owner's mailing address	Owner's Agent's mailing address
Adjacent and confronting Property Owners mailing addresses	

Description of Property: Please describe the building and surrounding environment. Include information on significant structures, landscape features, or other significant features of the property:

Single family home with circular driveway and shared driveway

Description of Work Proposed: Please give an overview of the work to be undertaken:

Replacement of windows in kind, wood/clad replacement with mullions to match existing.

Work Item 1: _____	
Description of Current Condition: Replace old non-functioning windows	Proposed Work: with new 'in kind' replacement wood/clad windows

Work Item 2: _____	
Description of Current Condition:	Proposed Work:

Work Item 3: _____	
Description of Current Condition:	Proposed Work:

**HISTORIC AREA WORK PERMIT
CHECKLIST OF
APPLICATION REQUIREMENTS**

	Required Attachments						
Proposed Work	I. Written Description	2. Site Plan	3. Plans/ Elevations	4. Material Specifications	5. Photographs	6. Tree Survey	7. Property Owner Addresses
New Construction	*	*	*	*	*	*	*
Additions/ Alterations	*	*	*	*	*	*	*
Demolition	*	*	*		*		*
Deck/Porch	*	*	*	*	*	*	*
Fence/Wall	*	*	*	*	*	*	*
Driveway/ Parking Area	*	*		*	*	*	*
Grading/Exc avation/Land scaing	*	*		*	*	*	*
Tree Removal	*	*		*	*	*	*
Siding/ Roof Changes	*	*	*	*	*		*
Window/ Door Changes	*	*	*	*	*		*
Masonry Repair/ Repoint	*	*	*	*	*		*
Signs	*	*	*	*	*		*



3

1 a

4

1 b

2

5



38

39

40

6

7



10
11 12

13 14

8

9



arch on 36 will remain as is





37













WINDOW 1a and 1b

THIS DRAWING AND THE INFORMATION IT CONTAINS ARE THE PROPERTY OF KOLBE & KOLBE MILLWORK CO., INC. AND ARE PROPRIETARY AND CONFIDENTIAL TO KOLBE & KOLBE MILLWORK CO., INC. ANY UNAUTHORIZED PUBLICATION, COPYING, USE, REPRODUCTION, DISCLOSURE OR DISSEMINATION OF THE DRAWING OR INFORMATION BY ANY MEANS (INCLUDING ELECTRONIC MEANS) IS PROHIBITED.

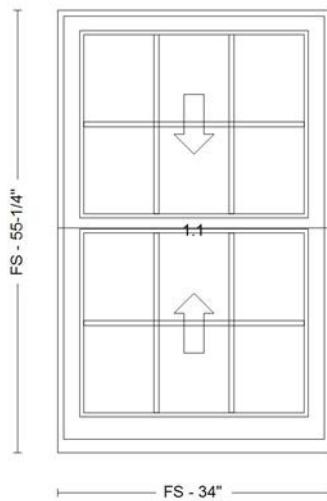

FS: 34" X 55-1/4"
 RO: 34-1/2" X 55-13/16"
 UD: 34" X 55-1/4"

Ultra Rectangle Double Hung
 UDH (Assy 1)

NOT FOR PRODUCTION USE

CUSTOMER: MERIT COMMERCIAL WINDOWS, INC	LINE: 009-1	QUANTITY: 2
PRINTED BY: STEVE DAVIS	LABEL: FRONT LEFT BEDROOM	
PROJECT: 45 W LENOX STREET		
QUOTE 1217694: 45 W LENOX STREET	PK VERSION: 759	
PRINTED: 6/19/2023 3:34 PM		

WINDOW 1a and 1b

Quote 1217694C: 45 W LENOX STREET

Merit Commercial Windows, Inc

6/19/2023 3:31:55 PM

Window and Door Details

Line Number **009-1**
 Label **FRONT LEFT BEDROOM**
 Product Name **Ultra Rectangle Double Hung (UDH)**
 Configured in PK Version **759**

Scaled To Fit

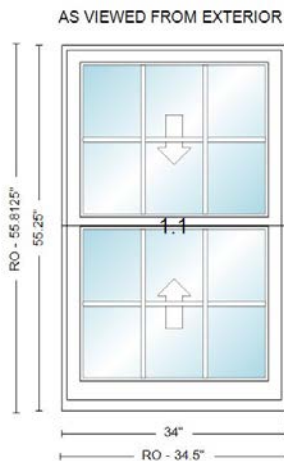

Quantity **1**
 Cubic Feet **9.23**
 Unit Price **\$2,381.28**
 Extended Price **\$2,381.28**

*** Pricing Details ***

Base Price **\$1,011.32**
 Lower Glass PDL **\$245.25**
 Upper Glass PDL **\$245.25**
 Screen **\$50.21**
 Non-Standard Size **\$265.13**
 Hardware Color **\$54.03**
 Lower Glass Glass **\$6.98**
 Upper Glass Glass **\$6.98**
 Screen Prep **\$34.15**
 Interior Finish **\$287.23**
 Lower Glass Lite Finish **\$87.37**
 Upper Glass Lite Finish **\$87.37**

*** Overall Dimensions ***

Overall Frame Width **34"**
 Overall Frame Height **55 1/4"**
 Overall Rough Opening Width **34 1/2"**
 Overall Rough Opening Height **55 13/16"**
 Overall Unit Dimension Width **34"**
 Overall Unit Dimension Height **55 1/4"**

*** Dimensions ***

Call Width **Custom**
 Call Height **Custom**
 Individual Frame Width **34"**
 Individual Frame Height **55 1/4"**
 Clear Opening Width **30 15/32"**
 Clear Opening Height **21 25/32"**

Glass Width **28 1/2"**
 Glass Height **23 13/32"**

*** Casing-Jamb-Trim ***

Exterior Casing/Accessories **No Casing**
 Sill Nosing **No Sill Nosing**
 Nailing Fin **No**
 Back Priming of Frame **No**
 Jamb Depth **4 9/16"**
 Installation Clips **None**
 Kolbe Installation Consulting **No**

*** Performance ***

Performance **Standard Performance**

*** Unit ***

Unit Type **Complete Unit**
 Unit Package **No Package**
 Model **Sterling**
 Production **Current**
 Vintage **#1117**
 Sash Material **Extruded**
 Basic Jamb Profile **Square**

*** Glass ***

Glass Make Up **Double Glazed**
 Glass **Solar Low-E**
 Glass Spacer **Mill Finish**
 High Altitude **No**
 Glass Preserve / Neat+ Coating **Glass Preserve without Neat+ Coating**
 Glazing Bead **Ovolo**
 Upper Glass - Glass Type **Clear**
 Upper Glass - Obscure / Opaque Glass **None**
 Upper Glass **NOT Tempered**
 Lower Glass - Glass Type **Clear**
 Lower Glass - Obscure / Opaque Glass **None**
 Lower Glass **NOT Tempered**

*** Lite Divisions - Upper ***

Lite Division **Performance Divided Lites**
 Bar Profile - Exterior **Beveled**
 Bar Profile - Interior **Ovolo**
 Bar Size **5/8"**
 Internal Spacers **Champagne**
 Second Bar Size **None**
 Grid Pattern **Colonial**
 Colonial Division **3W2H**
 Grille Division Type **Specified**

*** Lite Divisions - Lower ***

Lite Division **Performance Divided Lites**
 Bar Profile - Exterior **Beveled**
 Bar Profile - Interior **Ovolo**
 Bar Size **5/8"**
 Internal Spacers **Champagne**



Printed By: Steve Davis

Created: 5/26/2023

This report does not include Non-Kolbe Items

2023 Pricing

Window and Door Details Page 40 of 76

For warranty information please click this link or visit <https://www.kolbewindows.com/resources/warranties>

WINDOW 1a and 1b

Quote 1217694C: 45 W LENOX STREET

Merit Commercial Windows, Inc

6/19/2023 3:31:55 PM

Window and Door Details

Second Bar Size	None
Grid Pattern	Colonial
Colonial Divison	3W2H
Grille Division Type	Specified
Lite Bar Alignment	Align Vertical

*** Hardware-Accessories ***

Lock Style	Spoon
Hardware Color	Antique Brass
Bottom Sash Lift Handle(s)	No
Screen	Half Screen
Mesh Type	BetterVue Fiberglass
Screen(s) Applied	No
Ogee Lugs	No
Jambliner	Black
Window Opening Control Device	No
Class 5 Balance	No

*** Species-Finish-Color ***

Change Species	Leave All Pine
Exterior Frame Finish	70% Fluoropolymer
Exterior Sash Finish	70% Fluoropolymer
Match All Exterior Colors	Yes
Exterior Color	Ultra Pure White
Interior Frame Finish	Colored Prefinish
Interior Sash Finish	Colored Prefinish
Match All Interior Colors	Yes
Interior Color	Ultra Pure White
Jambliner Cover	Wood Wrapped
Vertical Weatherstrip Color	Black
Fingerjoints	Standard Fingerjoints



Printed By: Steve Davis

Created: 5/26/2023

This report does not include Non-Kolbe Items

2023 Pricing

Window and Door Details Page 41 of 76

For warranty information please click this link or visit <https://www.kolbewindows.com/resources/warranties>

WINDOW 1a and 1b

Quote 1217694C: 45 W LENOX STREET

Merit Commercial Windows, Inc

6/19/2023 3:31:55 PM

008 FRONT LEFT BEDROOM EA (2) 12.01 \$2,774.46 \$2,774.46

*** Unit ***

UDH (Assy 1)

Ultra Rectangle Double Hung

*** Unit ***

Unit 1.1: #1117 Vintage, Extruded Sash, Sterling, Square Basic Jamb Profile

*** Glass ***

Unit 1.1: Solar Low-E Glass

*** Lite Divisions ***

Unit 1.1 Lower: Performance Divided Lites, Colonial, Align Vertical Bars, 4W2H, 5/8" Bars, Beveled Bars - Exterior

Unit 1.1 Upper: Performance Divided Lites, Colonial, 4W2H, 5/8" Bars, Beveled Bars - Exterior

*** Hardware-Accessories ***

Unit 1.1: Antique Brass Hardware, Spoon Lock, BetterVue Fiberglass Half Screen, Screen(s) Loose

*** Species-Finish-Color ***

Unit 1.1: 70% Fluoropolymer Exterior Sash, 70% Fluoropolymer Exterior Frame, Ultra Pure White Exterior, Colored Prefinish Interior Sash, Colored Prefinish Interior Frame, Ultra Pure White Interior, Wood Wrapped Jambliner, Black Vertical Weatherstrip

*** Casing-Jambs-Trim ***

Unit 1.1: No Casing, No Sill Nosing, No Nailing Fin, 4-9/16" Jambs

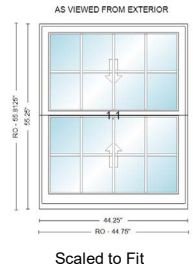

Rough Opening:
44 3/4" X 55 13/16"

Frame Size:
44 1/4" X 55 1/4"

Unit Dimension:
44 1/4" X 55 1/4"



Printed By: Steve Davis

Created: 5/26/2023

* Indicates Increased Rough Opening

2023 Pricing

Summary Page 8 of 76

For warranty information please click this link or visit <https://www.kolbewindows.com/resources/warranties>

WINDOW 2

THIS DRAWING AND THE INFORMATION IT CONTAINS ARE THE PROPERTY OF KOLBE & KOLBE MILLWORK CO., INC. AND ARE PROPRIETARY AND CONFIDENTIAL TO KOLBE & KOLBE MILLWORK CO., INC. ANY UNAUTHORIZED PUBLICATION, COPYING, USE, REPRODUCTION, DISCLOSURE OR DISSEMINATION OF THE DRAWING OR INFORMATION BY ANY MEANS (INCLUDING ELECTRONIC MEANS) IS PROHIBITED.

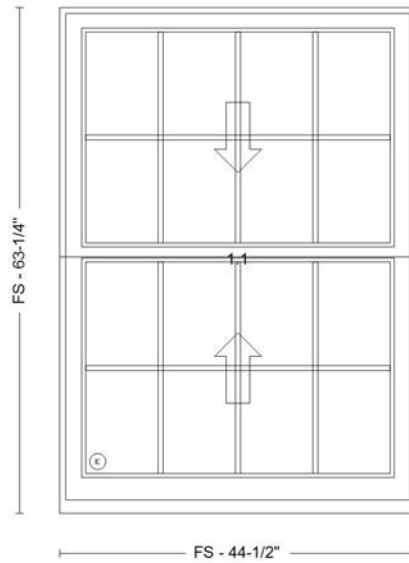

FS: 44-1/2" X 63-1/4"
 RO: 45" X 63-13/16"
 UD: 44-1/2" X 63-1/4"

Ultra Rectangle Double Hung
 UDH (Assy 1)

NOT FOR PRODUCTION USE

CUSTOMER: MERIT COMMERCIAL WINDOWS, INC	LINE: 004-1	QUANTITY: 1
PRINTED BY: STEVE DAVIS	LABEL: FRONT-OFFICE/ LAUNDRY	
PROJECT: 45 W LENOX STREET		
QUOTE 1217694: 45 W LENOX STREET	PK VERSION: 759	
PRINTED: 6/19/2023 3:34 PM		

WINDOW 2

Quote 1217694C: 45 W LENOX STREET

Merit Commercial Windows, Inc

6/19/2023 3:31:55 PM

Window and Door Details

Line Number **004-1**
 Label **FRONT-OFFICE/ LAUNDRY**
 Product Name **Ultra Rectangle Double Hung (UDH)**
 Configured in PK Version **759**

Scaled To Fit

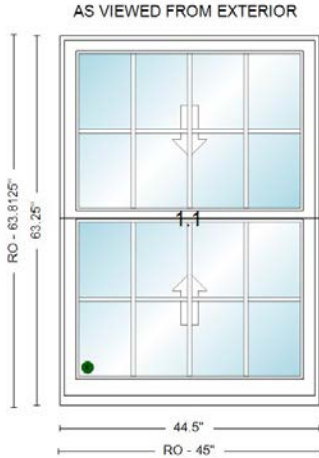

Quantity **(1)**
 Cubic Feet **13.82**
 Unit Price **\$2,911.13**
 Extended Price **\$2,911.13**

*** Pricing Details ***

Base Price **\$1,242.30**
 Lower Glass PDL **\$327.00**
 Upper Glass PDL **\$327.00**
 Screen **\$60.26**
 Non-Standard Size **\$265.13**
 Hardware Color **\$54.03**
 Lower Glass Glass **\$10.90**
 Upper Glass Glass **\$10.90**
 Screen Prep **\$34.15**
 Interior Finish **\$346.48**
 Lower Glass Lite Finish **\$116.50**
 Upper Glass Lite Finish **\$116.50**

*** Notes ***

Manufacturer Note: Opening(s) designated by a circled 'E' meet most national building codes for emergency escape and rescue requirements. Check local codes for product compliance for desired application.

Manufacturer Note: Individual Grille Division Type defaults may not always align with each other in certain mull/stack configurations. Please check layouts for acceptability and adjust if necessary.

*** Overall Dimensions ***

Overall Frame Width **44 1/2"**
 Overall Frame Height **63 1/4"**
 Overall Rough Opening Width **45"**
 Overall Rough Opening Height **63 13/16"**
 Overall Unit Dimension Width **44 1/2"**
 Overall Unit Dimension Height **63 1/4"**

*** Dimensions ***



Printed By: Steve Davis

Created: 5/26/2023

This report does not include Non-Kolbe Items

2023 Pricing

Window and Door Details Page 31 of 76

For warranty information please click this link or visit <https://www.kolbewindows.com/resources/warranties>

Call Width **Custom**
 Call Height **Custom**
 Individual Frame Width **44 1/2"**
 Individual Frame Height **63 1/4"**
 Clear Opening Width **40 31/32"**
 Clear Opening Height **25 25/32"**
 Glass Width **39"**
 Glass Height **27 13/32"**

*** Casing-Jamb-Trim ***

Exterior Casing/Accessories **No Casing**
 Sill Nosing **No Sill Nosing**
 Nailing Fin **No**
 Back Priming of Frame **No**
 Jamb Depth **4 9/16"**
 Installation Clips **None**
 Kolbe Installation Consulting **No**

*** Performance ***

Performance **Standard Performance**

*** Unit ***

Unit Type **Complete Unit**
 Unit Package **No Package**
 Model **Sterling**
 Production **Current**
 Vintage **#1117**
 Sash Material **Extruded**
 Basic Jamb Profile **Square**

*** Glass ***

Glass Make Up **Double Glazed**
 Glass **Solar Low-E**
 Glass Spacer **Mill Finish**
 High Altitude **No**
 Glass Preserve / Neat+ Coating **Glass Preserve without Neat+ Coating**
 Glazing Bead **Ovolo**
 Upper Glass - Glass Type **Clear**
 Upper Glass - Obscure / Opaque Glass **None**
 Upper Glass **NOT Tempered**
 Lower Glass - Glass Type **Clear**
 Lower Glass - Obscure / Opaque Glass **None**
 Lower Glass **NOT Tempered**

*** Lite Divisions - Upper ***

Lite Division **Performance Divided Lites**
 Bar Profile - Exterior **Beveled**
 Bar Profile - Interior **Ovolo**
 Bar Size **5/8"**
 Internal Spacers **Champagne**
 Second Bar Size **None**
 Grid Pattern **Colonial**
 Colonial Division **4W2H**
 Grille Division Type **Specified**

Window and Door Details

*** Lite Divisions - Lower ***

Lite Division	Performance Divided Lites
Bar Profile - Exterior	Beveled
Bar Profile - Interior	Ovolo
Bar Size	5/8"
Internal Spacers	Champagne
Second Bar Size	None
Grid Pattern	Colonial
Colonial Divison	4W2H
Lite Bar Alignment	Align Vertical

*** Hardware-Accessories ***

Lock Style	Spoon
Hardware Color	Antique Brass
Bottom Sash Lift Handle(s)	No
Screen	Half Screen
Mesh Type	BetterVue Fiberglass
Screen(s) Applied	No
Ogee Lugs	No
Jambliner	Black
Window Opening Control Device	No
Class 5 Balance	No

*** Species-Finish-Color ***

Change Species	Leave All Pine
Exterior Frame Finish	70% Fluoropolymer
Exterior Sash Finish	70% Fluoropolymer
Match All Exterior Colors	Yes
Exterior Color	Ultra Pure White
Interior Frame Finish	Colored Prefinish
Interior Sash Finish	Colored Prefinish
Match All Interior Colors	Yes
Interior Color	Ultra Pure White
Jambliner Cover	Wood Wrapped
Vertical Weatherstrip Color	Black
Fingerjoints	Standard Fingerjoints



WINDOW 2

Quote 1217694C: 45 W LENOX STREET

Merit Commercial Windows, Inc

6/19/2023 3:31:55 PM

004 FRONT-OFFICE/ LAUNDRY EA (1) 13.82 \$2,911.13 \$2,911.13

*** Unit ***
UDH (Assy 1)

Ultra Rectangle Double Hung

*** Unit ***
Unit 1.1: #1117 Vintage, Extruded Sash, Sterling, Square Basic Jamb Profile

*** Glass ***
Unit 1.1: Solar Low-E Glass

*** Lite Divisions ***
Unit 1.1 Lower: Performance Divided Lites, Colonial, Align Vertical Bars, 4W2H, 5/8" Bars, Beveled Bars - Exterior

Unit 1.1 Upper: Performance Divided Lites, Colonial, 4W2H, 5/8" Bars, Beveled Bars - Exterior

*** Hardware-Accessories ***
Unit 1.1: Antique Brass Hardware, Spoon Lock, BetterVue Fiberglass Half Screen, Screen(s) Loose

*** Species-Finish-Color ***
Unit 1.1: 70% Fluoropolymer Exterior Sash, 70% Fluoropolymer Exterior Frame, Ultra Pure White Exterior, Colored Prefinish Interior Sash, Colored Prefinish Interior Frame, Ultra Pure White Interior, Wood Wrapped Jambliner, Black Vertical Weatherstrip

*** Casing-Jambs-Trim ***
Unit 1.1: No Casing, No Sill Nosing, No Nailing Fin, 4-9/16" Jambs

Opening(s) designated by a circled 'E' meet most national building codes for emergency escape and rescue requirements. Check local codes for product compliance for desired application. Individual Grille Division Type defaults may not always align with each other in certain mull/stack configurations. Please check layouts for acceptability and adjust if necessary.

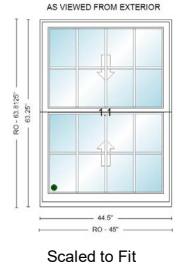

Rough Opening:
45" X 63 13/16"

Frame Size:
44 1/2" X 63 1/4"

Unit Dimension:
44 1/2" X 63 1/4"



Printed By: Steve Davis
Created: 5/26/2023

* Indicates Increased Rough Opening

2023 Pricing
Summary Page 5 of 76

For warranty information please click this link or visit <https://www.kolbewindows.com/resources/warranties>

WINDOW 3

THIS DRAWING AND THE INFORMATION IT CONTAINS ARE THE PROPERTY OF KOLBE & KOLBE MILLWORK CO., INC. AND ARE PROPRIETARY AND CONFIDENTIAL TO KOLBE & KOLBE MILLWORK CO., INC. ANY UNAUTHORIZED PUBLICATION, COPYING, USE, REPRODUCTION, DISCLOSURE OR DISSEMINATION OF THE DRAWING OR INFORMATION BY ANY MEANS (INCLUDING ELECTRONIC MEANS) IS PROHIBITED.



SPECIAL UNIT - MAY EXTEND LEADTIM

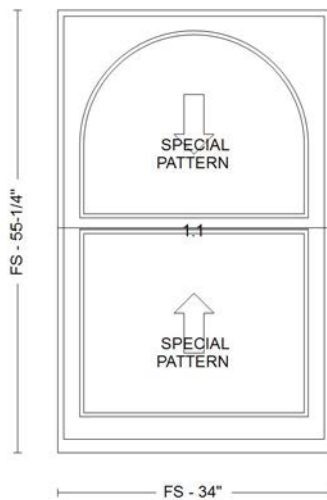

FS: 34" X 55-1/4"

RO: 34-1/2" X 55-13/16"

UD: 34" X 55-1/4"

Ultra Rectangle Out - Half Circle In Double Hung
UDH (Assy 1)

NOT FOR PRODUCTION USE

CUSTOMER: MERIT COMMERCIAL WINDOWS, INC	LINE: 016-1	QUANTITY: 1
PRINTED BY: STEVE DAVIS	LABEL: 3RD FL FRONT AT STAIR	
PROJECT: 45 W LENOX STREET		
QUOTE 1217694: 45 W LENOX STREET	PK VERSION: 759	
PRINTED: 6/19/2023 3:34 PM		

WINDOW 3

Quote 1217694C: 45 W LENOX STREET

Merit Commercial Windows, Inc

6/19/2023 3:31:55 PM

Window and Door Details

Line Number **016-1**
 Label **3RD FL FRONT AT STAIR**
 Product Name **Ultra Rectangle Out - Half Circle In Double Hung (UDH)**
 Configured in PK Version **759**

SPECIAL UNIT - MAY EXTEND LEADTIME

AS VIEWED FROM EXTERIOR

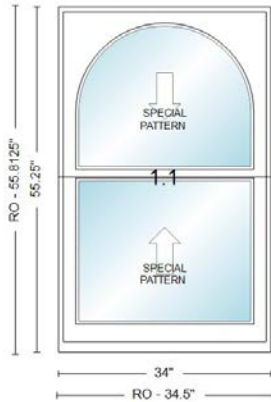

Scaled To Fit

Quantity **(1)**
 Cubic Feet **9.23**
 Unit Price **\$4,131.84**
 Extended Price **\$4,131.84**

*** Pricing Details ***

Base Price **\$1,914.17**
 Lower Glass PDL **\$245.25**
 Screen **\$50.21**
 Non-Standard Size **\$265.13**
 Hardware Color **\$54.03**
 Lower Glass Glass **\$6.98**
 Upper Glass Glass **\$14.21**
 Screen Prep **\$34.15**
 Mixed Colors **\$47.20**
 Interior Finish **\$287.23**
 Upper Glass A Lites **\$81.75**
 Upper Glass B Lites **\$55.64**
 Upper Glass C Lites **\$901.15**
 Lower Glass Lite Finish **\$87.37**
 Upper Glass Lite Finish **\$87.37**

*** Notes ***

Manufacturer Note: Drop will always be Daylight Opening Drop for all radius in square out units.

Manufacturer Note: Ultra Square Out Radius In sash will be wood with K-Kron2.

*** Overall Dimensions ***

Overall Frame Width **34"**
 Overall Frame Height **55 1/4"**
 Overall Rough Opening Width **34 1/2"**
 Overall Rough Opening Height **55 13/16"**
 Overall Unit Dimension Width **34"**

Overall Unit Dimension Height **55 1/4"**

*** Dimensions ***

Call Width **Custom**
 Call Height **Custom**
 Individual Frame Width **34"**
 Individual Frame Height **55 1/4"**
 Clear Opening Width **30 15/32"**
 Clear Opening Height **21 25/32"**
 Overall DLO Short Side **8 21/32"**
 Overall DLO Radius **13 3/4"**
 Glass Width **28 1/2"**
 Glass Height **23 13/32"**

*** Casing-Jamb-Trim ***

Exterior Casing/Accessories **No Casing**
 Sill Nosing **No Sill Nosing**
 Nailing Fin **No**
 Back Priming of Frame **No**
 Jamb Depth **4 9/16"**
 Installation Clips **None**
 Kolbe Installation Consulting **No**

*** Performance ***

Performance **Standard Performance**
 Job Specification PG Rating Entry **Do Not Specify**

*** Unit ***

Unit Type **Complete Unit**
 Unit Package **No Package**
 Model **Sterling**
 Production **Current**
 Vintage **#1117**
 Radius Blind Stop/Casing **No**
 Sash Material **Wood**
 Basic Jamb Profile **Square**

*** Glass ***

Glass Make Up **Double Glazed**
 Glass **Solar Low-E**
 Glass Spacer **Mill Finish**
 High Altitude **No**
 Glass Preserve / Neat+ Coating **Glass Preserve without Neat+ Coating**
 Glazing Bead **Ovolo**
 Upper Glass - Glass Type **Clear**
 Upper Glass - Obscure / Opaque Glass **None**
 Upper Glass **NOT Tempered**
 Lower Glass - Glass Type **Clear**
 Lower Glass - Obscure / Opaque Glass **None**
 Lower Glass **NOT Tempered**

*** Lite Divisions - Upper ***

Lite Division **Performance Divided Lites**
 Bar Profile - Exterior **Beveled**
 Bar Profile - Interior **Ovolo**



Printed By: Steve Davis

Created: 5/26/2023

This report does not include Non-Kolbe Items

2023 Pricing

Window and Door Details Page 54 of 76

For warranty information please click this link or visit <https://www.kolbewindows.com/resources/warranties>

WINDOW 3

Quote 1217694C: 45 W LENOX STREET

Merit Commercial Windows, Inc

6/19/2023 3:31:55 PM

Window and Door Details

Bar Size	5/8"
Internal Spacers	Champagne
Second Bar Size	None
Grid Pattern	Special
Grid Pattern Description	6 PDL lites per photo attached
Grille Division Type	Specified
*** Lite Divisions - Lower ***	
Lite Division	Performance Divided Lites
Bar Profile - Exterior	Beveled
Bar Profile - Interior	Ovolo
Bar Size	5/8"
Internal Spacers	Champagne
Second Bar Size	None
Grid Pattern	Special
Grid Pattern Description	3W2H
Grille Division Type	Specified
*** Hardware-Accessories ***	
Lock Style	Spoon
Hardware Color	Antique Brass
Bottom Sash Lift Handle(s)	No
Screen	Half Screen
Mesh Type	BetterVue Fiberglass
Screen(s) Applied	No
Ogee Lugs	No
Jambliner	Black
Window Opening Control Device	No
Class 5 Balance	No
*** Species-Finish-Color ***	
Change Species	Leave All Pine
Exterior Frame Finish	70% Fluoropolymer
Exterior Sash Finish	K-Kron2
Exterior Frame Color	Ultra Pure White
Exterior Sash Color	Ultra Pure White
Exterior Divided Lite Bar Color	Ultra Pure White
Interior Frame Finish	Colored Prefinish
Interior Sash Finish	Colored Prefinish
Match All Interior Colors	Yes
Interior Color	Ultra Pure White
Screen Color	White
Jambliner Cover	Wood Wrapped
Vertical Weatherstrip Color	Black
Fingerjoints	Standard Fingerjoints



Printed By: Steve Davis

Created: 5/26/2023

This report does not include Non-Kolbe Items

2023 Pricing

Window and Door Details Page 55 of 76

For warranty information please click this link or visit <https://www.kolbewindows.com/resources/warranties>

WINDOW 3

Quote 1217694C: 45 W LENOX STREET

Merit Commercial Windows, Inc

6/19/2023 3:31:55 PM

016 3RD FL FRONT AT STAIR EA (1) 9.23 \$4,131.84 \$4,131.84

*** Unit ***

UDH (Assy 1)

Ultra Rectangle Out - Half Circle In Double Hung

*** Unit ***

Unit 1.1: #1117 Vintage, Wood Sash, Sterling, Square Basic Jamb Profile

*** Glass ***

Unit 1.1: Solar Low-E Glass

*** Lite Divisions ***

Unit 1.1 Lower, 1.1 Upper: Performance Divided Lites, Special, 5/8" Bars, Beveled Bars - Exterior

*** Hardware-Accessories ***

Unit 1.1: Antique Brass Hardware, Spoon Lock, BetterVue Fiberglass Half Screen, Screen(s) Loose

*** Species-Finish-Color ***

Unit 1.1: K-Kron2 Exterior Sash, Ultra Pure White 70% Fluoropolymer Exterior Frame, Ultra Pure White Exterior Sash, Colored Prefinish Interior Sash, Colored Prefinish Interior Frame, Ultra Pure White Interior, White Screen, Wood Wrapped Jambliner, Black Vertical Weatherstrip

*** Casing-Jambs-Trim ***

Unit 1.1: No Casing, No Sill Nosing, No Nailing Fin, 4-9/16" Jambs

Drop will always be Daylight Opening Drop for all radius in square out units.

Ultra Square Out Radius In sash will be wood with K-Kron2.

SPECIAL UNIT - MAY EXTEND LEADTIME
AS VIEWED FROM EXTERIOR

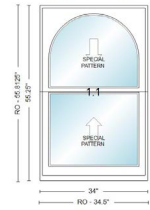

Rough Opening:
34 1/2" X 55 13/16"

Frame Size:
34" X 55 1/4"

Unit Dimension:
34" X 55 1/4"



Printed By: Steve Davis

Created: 5/26/2023

* Indicates Increased Rough Opening

2023 Pricing

Summary Page 16 of 76

For warranty information please click this link or visit <https://www.kolbewindows.com/resources/warranties>

WINDOW 4

THIS DRAWING AND THE INFORMATION IT CONTAINS ARE THE PROPERTY OF KOLBE & KOLBE MILLWORK CO., INC. AND ARE PROPRIETARY AND CONFIDENTIAL TO KOLBE & KOLBE MILLWORK CO., INC. ANY UNAUTHORIZED PUBLICATION, COPYING, USE, REPRODUCTION, DISCLOSURE OR DISSEMINATION OF THE DRAWING OR INFORMATION BY ANY MEANS (INCLUDING ELECTRONIC MEANS) IS PROHIBITED.

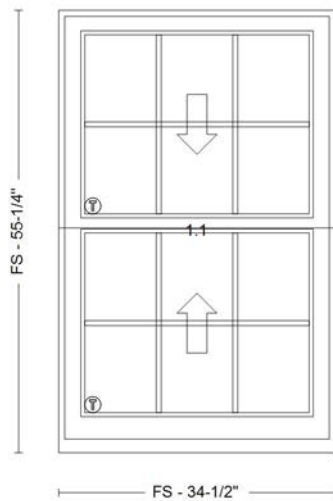

FS: 34-1/2" X 55-1/4"

RO: 35" X 55-13/16"

UD: 34-1/2" X 55-1/4"

Ultra Rectangle Double Hung
UDH (Assy 1)

NOT FOR PRODUCTION USE

CUSTOMER: MERIT COMMERCIAL WINDOWS, INC	LINE: 007-1	QUANTITY: 1
PRINTED BY: STEVE DAVIS	LABEL: FRONT-STAIR	
PROJECT: 45 W LENOX STREET		
QUOTE 1217694: 45 W LENOX STREET	PK VERSION: 759	
PRINTED: 6/19/2023 3:34 PM		

WINDOW 4

Quote 1217694C: 45 W LENOX STREET

Merit Commercial Windows, Inc

6/19/2023 3:31:55 PM

Window and Door Details

Line Number **007-1**
 Label **FRONT-STAIR**
 Product Name **Ultra Rectangle Double Hung (UDH)**
 Configured in PK Version **759**

Scaled To Fit

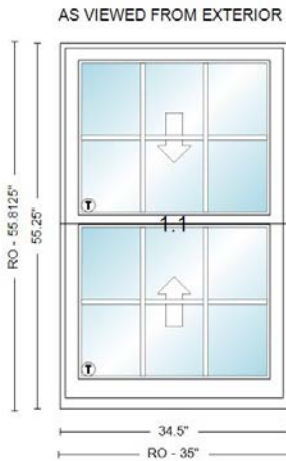

Quantity **(1)**
 Cubic Feet **9.36**
 Unit Price **\$2,537.13**
 Extended Price **\$2,537.13**

*** Pricing Details ***

Base Price **\$1,015.33**
 Lower Glass PDL **\$245.25**
 Upper Glass PDL **\$245.25**
 Screen **\$50.21**
 Non-Standard Size **\$265.13**
 Hardware Color **\$54.03**
 Lower Glass Glass **\$82.40**
 Upper Glass Glass **\$82.40**
 Screen Prep **\$34.15**
 Interior Finish **\$288.23**
 Lower Glass Lite Finish **\$87.37**
 Upper Glass Lite Finish **\$87.37**

*** Overall Dimensions ***

Overall Frame Width **34 1/2"**
 Overall Frame Height **55 1/4"**
 Overall Rough Opening Width **35"**
 Overall Rough Opening Height **55 13/16"**
 Overall Unit Dimension Width **34 1/2"**
 Overall Unit Dimension Height **55 1/4"**

*** Dimensions ***

Call Width **Custom**
 Call Height **Custom**
 Individual Frame Width **34 1/2"**
 Individual Frame Height **55 1/4"**
 Clear Opening Width **30 31/32"**
 Clear Opening Height **21 25/32"**

Glass Width **29"**
 Glass Height **23 13/32"**

*** Casing-Jamb-Trim ***

Exterior Casing/Accessories **No Casing**
 Sill Nosing **No Sill Nosing**
 Nailing Fin **No**
 Back Priming of Frame **No**
 Jamb Depth **4 9/16"**
 Installation Clips **None**
 Kolbe Installation Consulting **No**

*** Performance ***

Performance **Standard Performance**

*** Unit ***

Unit Type **Complete Unit**
 Unit Package **No Package**
 Model **Sterling**
 Production **Current**
 Vintage **#1117**
 Sash Material **Extruded**
 Basic Jamb Profile **Square**

*** Glass ***

Glass Make Up **Double Glazed**
 Glass **Solar Low-E**
 Glass Spacer **Mill Finish**
 High Altitude **No**
 Glass Preserve / Neat+ Coating **Glass Preserve without Neat+ Coating**
 Glazing Bead **Ovolo**
 Upper Glass - Glass Type **Clear**
 Upper Glass - Obscure / Opaque Glass **None**
 Upper Glass **Tempered**
 Lower Glass - Glass Type **Clear**
 Lower Glass - Obscure / Opaque Glass **None**
 Lower Glass **Tempered**

*** Lite Divisions - Upper ***

Lite Division **Performance Divided Lites**
 Bar Profile - Exterior **Beveled**
 Bar Profile - Interior **Ovolo**
 Bar Size **5/8"**
 Internal Spacers **Champagne**
 Second Bar Size **None**
 Grid Pattern **Colonial**
 Colonial Division **3W2H**
 Grille Division Type **Specified**

*** Lite Divisions - Lower ***

Lite Division **Performance Divided Lites**
 Bar Profile - Exterior **Beveled**
 Bar Profile - Interior **Ovolo**
 Bar Size **5/8"**
 Internal Spacers **Champagne**



Printed By: Steve Davis

Created: 5/26/2023

This report does not include Non-Kolbe Items

2023 Pricing

Window and Door Details Page 36 of 76

For warranty information please click this link or visit <https://www.kolbewindows.com/resources/warranties>

WINDOW 4

Quote 1217694C: 45 W LENOX STREET

Merit Commercial Windows, Inc

6/19/2023 3:31:55 PM

Window and Door Details

Second Bar Size	None
Grid Pattern	Colonial
Colonial Divison	3W2H
Grille Division Type	Specified
Lite Bar Alignment	Align Vertical

*** Hardware-Accessories ***

Lock Style	Spoon
Hardware Color	Antique Brass
Bottom Sash Lift Handle(s)	No
Screen	Half Screen
Mesh Type	BetterVue Fiberglass
Screen(s) Applied	No
Ogee Lugs	No
Jambliner	Black
Window Opening Control Device	No
Class 5 Balance	No

*** Species-Finish-Color ***

Change Species	Leave All Pine
Exterior Frame Finish	70% Fluoropolymer
Exterior Sash Finish	70% Fluoropolymer
Match All Exterior Colors	Yes
Exterior Color	Ultra Pure White
Interior Frame Finish	Colored Prefinish
Interior Sash Finish	Colored Prefinish
Match All Interior Colors	Yes
Interior Color	Ultra Pure White
Jambliner Cover	Wood Wrapped
Vertical Weatherstrip Color	Black
Fingerjoints	Standard Fingerjoints



Printed By: Steve Davis

Created: 5/26/2023

This report does not include Non-Kolbe Items

2023 Pricing

Window and Door Details Page 37 of 76

For warranty information please click this link or visit <https://www.kolbewindows.com/resources/warranties>

WINDOW 4

007 FRONT-STAIR EA (1) 9.36 \$2,537.13 \$2,537.13

*** Unit ***

UDH (Assy 1)

Ultra Rectangle Double Hung

*** Unit ***

Unit 1.1: #1117 Vintage, Extruded Sash, Sterling, Square Basic Jamb Profile

*** Glass ***

Unit 1.1: Solar Low-E Glass

Unit 1.1 Lower, 1.1 Upper: Tempered Glass

*** Lite Divisions ***

Unit 1.1 Lower: Performance Divided Lites, Colonial, Align Vertical Bars, 3W2H, 5/8" Bars, Beveled Bars - Exterior

Unit 1.1 Upper: Performance Divided Lites, Colonial, 3W2H, 5/8" Bars, Beveled Bars - Exterior

*** Hardware-Accessories ***

Unit 1.1: Antique Brass Hardware, Spoon Lock, BetterVue Fiberglass Half Screen, Screen(s) Loose

*** Species-Finish-Color ***

Unit 1.1: 70% Fluoropolymer Exterior Sash, 70% Fluoropolymer Exterior Frame, Ultra Pure White Exterior, Colored Prefinish Interior Sash, Colored Prefinish Interior Frame, Ultra Pure White Interior, Wood Wrapped Jambliner, Black Vertical Weatherstrip

*** Casing-Jambs-Trim ***

Unit 1.1: No Casing, No Sill Nosing, No Nailing Fin, 4-9/16" Jambs

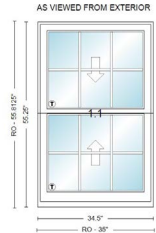

**Rough Opening:
35" X 55 13/16"**

**Frame Size:
34 1/2" X 55 1/4"**

**Unit Dimension:
34 1/2" X 55 1/4"**



WINDOW 5

THIS DRAWING AND THE INFORMATION IT CONTAINS ARE THE PROPERTY OF KOLBE & KOLBE MILLWORK CO., INC. AND ARE PROPRIETARY AND CONFIDENTIAL TO KOLBE & KOLBE MILLWORK CO., INC. ANY UNAUTHORIZED PUBLICATION, COPYING, USE, REPRODUCTION, DISCLOSURE OR DISSEMINATION OF THE DRAWING OR INFORMATION BY ANY MEANS (INCLUDING ELECTRONIC MEANS) IS PROHIBITED.

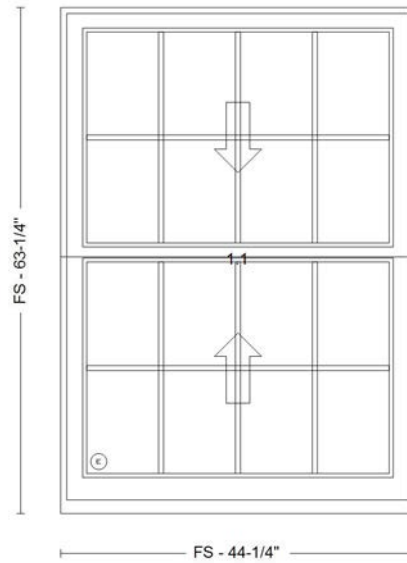

FS: 44-1/4" X 63-1/4"
 RO: 44-3/4" X 63-13/16"
 UD: 44-1/4" X 63-1/4"

Ultra Rectangle Double Hung
 UDH (Assy 1)

NOT FOR PRODUCTION USE

CUSTOMER: MERIT COMMERCIAL WINDOWS, INC	LINE: 001-1	QUANTITY: 1
PRINTED BY: STEVE DAVIS	LABEL: LIVING ROOM FRONT	
PROJECT: 45 W LENOX STREET		
QUOTE 1217694: 45 W LENOX STREET	PK VERSION: 759	
PRINTED: 6/19/2023 3:34 PM		

WINDOW 5

Quote 1217694C: 45 W LENOX STREET

Merit Commercial Windows, Inc

6/19/2023 3:31:55 PM

Line	Label	UOM	Quantity	Cubic Feet	Unit Price	Extended Price
------	-------	-----	----------	------------	------------	----------------

001	LIVING ROOM FRONT	EA	(1)	13.75	\$2,907.11	\$2,907.11
-----	-------------------	----	-------	-------	------------	------------

*** Unit ***
UDH (Assy 1)

Ultra Rectangle Double Hung

*** Unit ***
Unit 1.1: #1117 Vintage, Extruded Sash, Sterling, Square Basic Jamb Profile

*** Glass ***
Unit 1.1: Solar Low-E Glass

*** Lite Divisions ***
Unit 1.1 Lower: Performance Divided Lites, Colonial, Align Vertical Bars, 4W2H, 5/8" Bars, Beveled Bars - Exterior

Unit 1.1 Upper: Performance Divided Lites, Colonial, 4W2H, 5/8" Bars, Beveled Bars - Exterior

*** Hardware-Accessories ***
Unit 1.1: Antique Brass Hardware, Spoon Lock, BetterVue Fiberglass Half Screen, Screen(s) Loose

*** Species-Finish-Color ***
Unit 1.1: 70% Fluoropolymer Exterior Sash, 70% Fluoropolymer Exterior Frame, Ultra Pure White Exterior, Colored Prefinish Interior Sash, Colored Prefinish Interior Frame, Ultra Pure White Interior, Wood Wrapped Jambliner, Black Vertical Weatherstrip

*** Casing-Jambs-Trim ***
Unit 1.1: No Casing, No Sill Nosing, No Nailing Fin, 4-9/16" Jambs

Opening(s) designated by a circled 'E' meet most national building codes for emergency escape and rescue requirements. Check local codes for product compliance for desired application.
Individual Grille Division Type defaults may not always align with each other in certain mull/stack configurations.
Please check layouts for acceptability and adjust if necessary.

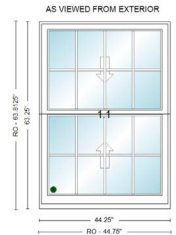

Scaled to Fit

Rough Opening:
44 3/4" X 63 13/16"

Frame Size:
44 1/4" X 63 1/4"

Unit Dimension:
44 1/4" X 63 1/4"



Printed By: Steve Davis
Created: 5/26/2023

* Indicates Increased Rough Opening

2023 Pricing
Summary Page 2 of 76

For warranty information please click this link or visit <https://www.kolbewindows.com/resources/warranties>

WINDOW 5

Quote 1217694C: 45 W LENOX STREET

Merit Commercial Windows, Inc

6/19/2023 3:31:55 PM

Window and Door Details

Line Number **001-1**
 Label **LIVING ROOM FRONT**
 Product Name **Ultra Rectangle Double Hung (UDH)**
 Configured in PK Version **759**

Scaled To Fit

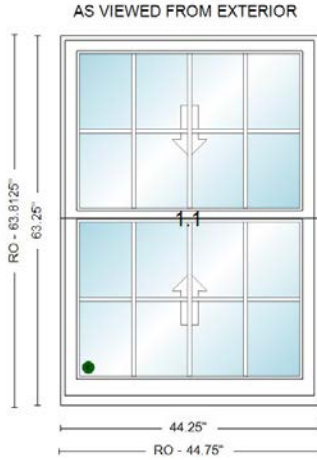

Quantity **(1)**
 Cubic Feet **13.75**
 Unit Price **\$2,907.11**
 Extended Price **\$2,907.11**

*** Pricing Details ***

Base Price **\$1,239.29**
 Lower Glass PDL **\$327.00**
 Upper Glass PDL **\$327.00**
 Screen **\$60.26**
 Non-Standard Size **\$265.13**
 Hardware Color **\$54.03**
 Lower Glass Glass **\$10.90**
 Upper Glass Glass **\$10.90**
 Screen Prep **\$34.15**
 Interior Finish **\$345.47**
 Lower Glass Lite Finish **\$116.50**
 Upper Glass Lite Finish **\$116.50**

*** Notes ***

Manufacturer Note: Opening(s) designated by a circled 'E' meet most national building codes for emergency escape and rescue requirements. Check local codes for product compliance for desired application.

Manufacturer Note: Individual Grille Division Type defaults may not always align with each other in certain mull/stack configurations. Please check layouts for acceptability and adjust if necessary.

*** Overall Dimensions ***

Overall Frame Width **44 1/4"**
 Overall Frame Height **63 1/4"**
 Overall Rough Opening Width **44 3/4"**
 Overall Rough Opening Height **63 13/16"**
 Overall Unit Dimension Width **44 1/4"**
 Overall Unit Dimension Height **63 1/4"**

*** Dimensions ***

Call Width **Custom**
 Call Height **Custom**
 Individual Frame Width **44 1/4"**
 Individual Frame Height **63 1/4"**
 Clear Opening Width **40 23/32"**
 Clear Opening Height **25 25/32"**
 Glass Width **38 3/4"**
 Glass Height **27 13/32"**

*** Casing-Jamb-Trim ***

Exterior Casing/Accessories **No Casing**
 Sill Nosing **No Sill Nosing**
 Nailing Fin **No**
 Back Priming of Frame **No**
 Jamb Depth **4 9/16"**
 Installation Clips **None**
 Kolbe Installation Consulting **No**

*** Performance ***

Performance **Standard Performance**
 *** Unit ***

Unit Type **Complete Unit**
 Unit Package **No Package**
 Model **Sterling**
 Production **Current**
 Vintage **#1117**
 Sash Material **Extruded**
 Basic Jamb Profile **Square**

*** Glass ***

Glass Make Up **Double Glazed**
 Glass **Solar Low-E**
 Glass Spacer **Mill Finish**
 High Altitude **No**
 Glass Preserve / Neat+ Coating **Glass Preserve without Neat+ Coating**
 Glazing Bead **Ovolo**
 Upper Glass - Glass Type **Clear**
 Upper Glass - Obscure / Opaque Glass **None**
 Upper Glass **NOT Tempered**
 Lower Glass - Glass Type **Clear**
 Lower Glass - Obscure / Opaque Glass **None**
 Lower Glass **NOT Tempered**

*** Lite Divisions - Upper ***

Lite Division **Performance Divided Lites**
 Bar Profile - Exterior **Beveled**
 Bar Profile - Interior **Ovolo**
 Bar Size **5/8"**
 Internal Spacers **Champagne**
 Second Bar Size **None**
 Grid Pattern **Colonial**
 Colonial Division **4W2H**
 Grille Division Type **Specified**



Printed By: Steve Davis

Created: 5/26/2023

This report does not include Non-Kolbe Items

2023 Pricing

Window and Door Details Page 25 of 76

For warranty information please click this link or visit <https://www.kolbewindows.com/resources/warranties>

Window and Door Details

*** Lite Divisions - Lower ***

Lite Division	Performance Divided Lites
Bar Profile - Exterior	Beveled
Bar Profile - Interior	Ovolo
Bar Size	5/8"
Internal Spacers	Champagne
Second Bar Size	None
Grid Pattern	Colonial
Colonial Divison	4W2H
Lite Bar Alignment	Align Vertical

*** Hardware-Accessories ***

Lock Style	Spoon
Hardware Color	Antique Brass
Bottom Sash Lift Handle(s)	No
Screen	Half Screen
Mesh Type	BetterVue Fiberglass
Screen(s) Applied	No
Ogee Lugs	No
Jambliner	Black
Window Opening Control Device	No
Class 5 Balance	No

*** Species-Finish-Color ***

Change Species	Leave All Pine
Exterior Frame Finish	70% Fluoropolymer
Exterior Sash Finish	70% Fluoropolymer
Match All Exterior Colors	Yes
Exterior Color	Ultra Pure White
Interior Frame Finish	Colored Prefinish
Interior Sash Finish	Colored Prefinish
Match All Interior Colors	Yes
Interior Color	Ultra Pure White
Jambliner Cover	Wood Wrapped
Vertical Weatherstrip Color	Black
Fingerjoints	Standard Fingerjoints



WINDOW 6

THIS DRAWING AND THE INFORMATION IT CONTAINS ARE THE PROPERTY OF KOLBE & KOLBE MILLWORK CO., INC. AND ARE PROPRIETARY AND CONFIDENTIAL TO KOLBE & KOLBE MILLWORK CO., INC. ANY UNAUTHORIZED PUBLICATION, COPYING, USE, REPRODUCTION, DISCLOSURE OR DISSEMINATION OF THE DRAWING OR INFORMATION BY ANY MEANS (INCLUDING ELECTRONIC MEANS) IS PROHIBITED.

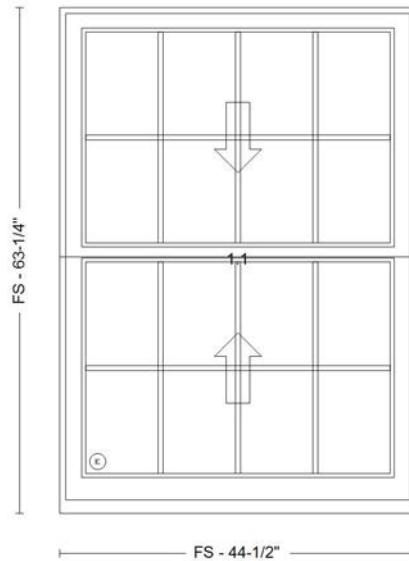

FS: 44-1/2" X 63-1/4"
 RO: 45" X 63-13/16"
 UD: 44-1/2" X 63-1/4"

Ultra Rectangle Double Hung
 UDH (Assy 1)

NOT FOR PRODUCTION USE

CUSTOMER: MERIT COMMERCIAL WINDOWS, INC	LINE: 004-1	QUANTITY: 1
PRINTED BY: STEVE DAVIS	LABEL: FRONT-OFFICE/ LAUNDRY	
PROJECT: 45 W LENOX STREET		
QUOTE 1217694: 45 W LENOX STREET	PK VERSION: 759	
PRINTED: 6/19/2023 3:34 PM		

WINDOW 6

Quote 1217694C: 45 W LENOX STREET

Merit Commercial Windows, Inc

6/19/2023 3:31:55 PM

Window and Door Details

Line Number **003-1**
 Label **LIVING ROOM SIDE**
 Product Name **Ultra Rectangle French Casement (UFC)**
 Configured in PK Version **759**

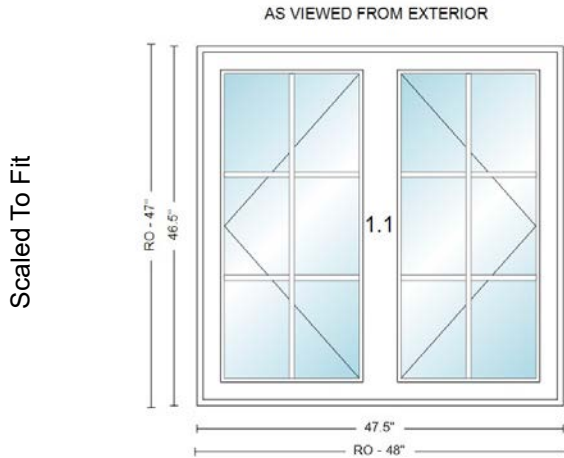

Quantity **(1)**
 Cubic Feet **9.69**
 Unit Price **\$4,624.14**
 Extended Price **\$4,624.14**

*** Pricing Details ***

Base Price **\$2,374.13**
 Left Glass PDL **\$245.25**
 Right Glass PDL **\$245.25**
 Screen **\$411.26**
 Non-Standard Size **\$318.36**
 Left Glass Glass **\$7.78**
 Right Glass Glass **\$7.78**
 Push-Out (Venting) **\$256.09**
 Interior Finish **\$371.59**
 Left Glass Lite Finish **\$87.37**
 Right Glass Lite Finish **\$87.37**
 Screen Finish **\$177.76**
 Screen Loose/Applied **\$34.15**

*** Overall Dimensions ***

Overall Frame Width **47 1/2"**
 Overall Frame Height **46 1/2"**
 Overall Rough Opening Width **48"**
 Overall Rough Opening Height **47"**
 Overall Unit Dimension Width **47 1/2"**
 Overall Unit Dimension Height **46 1/2"**

*** Dimensions ***

Call Width **Custom**
 Call Height **Custom**
 Individual Frame Width **47 1/2"**
 Individual Frame Height **46 1/2"**
 Clear Opening Width 1 **15 23/32"**

Clear Opening Height 1 **39 11/16"**
 Clear Opening Width 2 **33 3/8"**
 Clear Opening Height 2 **39 11/16"**
 Glass Width **18 15/32"**
 Glass Height **40 3/8"**

*** Casing-Jambs-Trim ***

Exterior Casing/Accessories **No Casing**
 Sill Nosing **No Sill Nosing**
 Nailing Fin **No**
 Back Priming of Frame **No**
 Jamb Depth **4 9/16"**
 Jambs Exact **No**
 Offset Jambs **No Offset**
 Jambs Applied **Yes**
 Installation Clips **None**
 Kolbe Installation Consulting **No**

*** Performance ***

Performance **Standard Performance**
 Unit Type **Complete Unit**
 Unit Package **No Package**
 Model **Push Out**
 Production **Current**
 Hinging **Left - Right**
 Sash Material **Extruded**

*** Unit ***

*** Glass ***

Glass Make Up **Double Glazed**
 Glass **Solar Low-E**
 Glass Spacer **Mill Finish**
 High Altitude **No**
 Glass Preserve / Neat+ Coating **Glass Preserve without Neat+ Coating**
 Glazing Bead **Ovolo**
 Left Glass - Glass Type **Clear**
 Left Glass - Obscure / Opaque Glass **None**
 Left Glass **NOT Tempered**
 Right Glass - Glass Type **Clear**
 Right Glass - Obscure / Opaque Glass **None**
 Right Glass **NOT Tempered**

*** Lite Divisions - Left ***

Lite Division **Performance Divided Lites**
 Bar Profile - Exterior **Beveled**
 Bar Profile - Interior **Ovolo**
 Bar Size **5/8"**
 Internal Spacers **Champagne**
 Second Bar Size **None**
 Grid Pattern **Colonial**
 Colonial Divison **2W3H**
 Grille Division Type **Specified**



Printed By: Steve Davis

Created: 5/26/2023

This report does not include Non-Kolbe Items

2023 Pricing

Window and Door Details Page 29 of 76

For warranty information please click this link or visit <https://www.kolbewindows.com/resources/warranties>

Window and Door Details

*** Lite Divisions - Right ***

Lite Division	Performance Divided Lites
Bar Profile - Exterior	Beveled
Bar Profile - Interior	Ovolo
Bar Size	5/8"
Internal Spacers	Champagne
Second Bar Size	None
Grid Pattern	Colonial
Colonial Division	2W3H
Grille Division Type	Specified
Lite Bar Alignment	Align Horizontal

*** Hardware-Accessories ***

Window Hardware	Multi-Point Lock
Hardware Color	Natural Brass
Screen	Retractable Screen
Retractable Screen with Recessed Head Location	No
Retractable Screen Side Cover	Beveled
Mesh Type	BetterVue Fiberglass
Screen(s) Applied	Yes

*** Species-Finish-Color ***

Change Species	Leave All Pine
Exterior Frame Finish	70% Fluoropolymer
Exterior Sash Finish	70% Fluoropolymer
Match All Exterior Colors	Yes
Exterior Color	Ultra Pure White
Interior Frame Finish	Colored Prefinish
Interior Sash Finish	Colored Prefinish
Match All Interior Colors	Yes
Interior Color	Ultra Pure White
Screen Color	White Channel with Black Weatherstrip
Screen Finish	Colored Prefinish
Screen Finish Color	Ultra Pure White
Fingerjoints	Standard Fingerjoints



WINDOW 6

Quote 1217694C: 45 W LENOX STREET

Merit Commercial Windows, Inc

6/19/2023 3:31:55 PM

003 LIVING ROOM SIDE EA (1) 9.69 \$4,624.14 \$4,624.14

*** Unit ***

UFC (Assy 1)

Ultra Rectangle French Casement

*** Unit ***

Unit 1.1: Extruded Sash, Push Out, Left - Right Hinging

*** Glass ***

Unit 1.1: Solar Low-E Glass

*** Lite Divisions ***

Unit 1.1 Left: Performance Divided Lites, Colonial, 2W3H, 5/8" Bars, Beveled Bars - Exterior

Unit 1.1 Right: Performance Divided Lites, Colonial, Align Horizontal Bars, 2W3H, 5/8" Bars, Beveled Bars - Exterior

*** Hardware-Accessories ***

Unit 1.1: Multi-Point Lock Window Hardware, Natural Brass Hardware, BetterVue Fiberglass Retractable Screen

*** Species-Finish-Color ***

Unit 1.1: 70% Fluoropolymer Exterior Sash, 70% Fluoropolymer Exterior Frame, Ultra Pure White Exterior, Colored Prefinish Interior Sash, Colored Prefinish Interior Frame, Ultra Pure White Interior, White Screen Channel with Black Weatherstrip, Ultra Pure White Colored Prefinish Screen

*** Casing-Jambs-Trim ***

Unit 1.1: No Casing, No Sill Nosing, No Nailing Fin, 4-9/16" Jambs

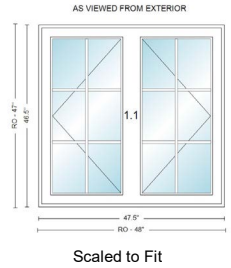

**Rough Opening:
48" X 47"**

**Frame Size:
47 1/2" X 46 1/2"**

**Unit Dimension:
47 1/2" X 46 1/2"**



Printed By: Steve Davis

Created: 5/26/2023

* Indicates Increased Rough Opening

2023 Pricing

Summary Page 4 of 76

For warranty information please click this link or visit <https://www.kolbewindows.com/resources/warranties>

WINDOW 7

THIS DRAWING AND THE INFORMATION IT CONTAINS ARE THE PROPERTY OF KOLBE & KOLBE MILLWORK CO., INC. AND ARE PROPRIETARY AND CONFIDENTIAL TO KOLBE & KOLBE MILLWORK CO., INC. ANY UNAUTHORIZED PUBLICATION, COPYING, USE, REPRODUCTION, DISCLOSURE OR DISSEMINATION OF THE DRAWING OR INFORMATION BY ANY MEANS (INCLUDING ELECTRONIC MEANS) IS PROHIBITED.

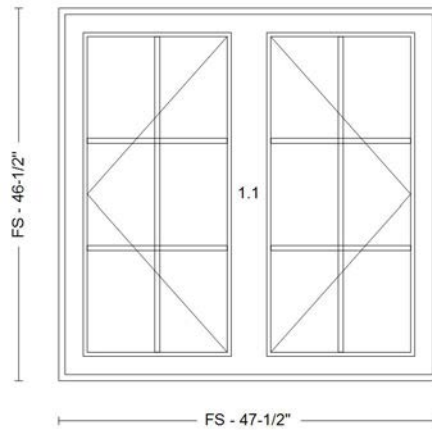

FS: 47-1/2" X 46-1/2"

RO: 48" X 47"

UD: 47-1/2" X 46-1/2"

Ultra Rectangle French Casement
UFC (Assy 1)

NOT FOR PRODUCTION USE

CUSTOMER: MERIT COMMERCIAL WINDOWS, INC	LINE: 003-1	QUANTITY: 1
PRINTED BY: STEVE DAVIS	LABEL: LIVING ROOM SIDE	
PROJECT: 45 W LENOX STREET		
QUOTE 1217694: 45 W LENOX STREET	PK VERSION: 759	
PRINTED: 6/19/2023 3:34 PM		

WINDOW 7

Quote 1217694C: 45 W LENOX STREET

Merit Commercial Windows, Inc

6/19/2023 3:31:55 PM

Window and Door Details

Line Number **002-1**
 Label **BAR FRONT**
 Product Name **Ultra Rectangle French Casement (UFC)**
 Configured in PK Version **759**

Scaled To Fit

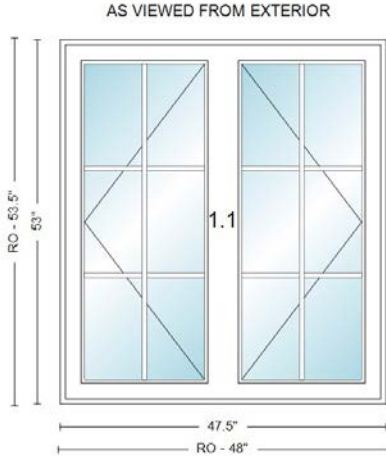

Quantity **(1)**
 Cubic Feet **12.37**
 Unit Price **\$4,883.25**
 Extended Price **\$4,883.25**

*** Pricing Details ***

Base Price **\$2,559.93**
 Left Glass PDL **\$245.25**
 Right Glass PDL **\$245.25**
 Screen **\$443.90**
 Non-Standard Size **\$318.36**
 Left Glass Glass **\$8.94**
 Right Glass Glass **\$8.94**
 Push-Out (Venting) **\$256.09**
 Interior Finish **\$396.69**
 Left Glass Lite Finish **\$87.37**
 Right Glass Lite Finish **\$87.37**
 Screen Finish **\$191.02**
 Screen Loose\Applied **\$34.15**

*** Overall Dimensions ***

Overall Frame Width **47 1/2"**
 Overall Frame Height **53"**
 Overall Rough Opening Width **48"**
 Overall Rough Opening Height **53 1/2"**
 Overall Unit Dimension Width **47 1/2"**
 Overall Unit Dimension Height **53"**

*** Dimensions ***

Call Width **Custom**
 Call Height **Custom**
 Individual Frame Width **47 1/2"**
 Individual Frame Height **53"**
 Clear Opening Width 1 **15 23/32"**

Clear Opening Height 1 **46 3/16"**
 Clear Opening Width 2 **33 3/8"**
 Clear Opening Height 2 **46 3/16"**
 Glass Width **18 15/32"**
 Glass Height **46 7/8"**

*** Casing-Jamb-Trim ***

Exterior Casing/Accessories **No Casing**
 Sill Nosing **No Sill Nosing**
 Nailing Fin **No**
 Back Priming of Frame **No**
 Jamb Depth **4 9/16"**
 Jamb-Exact **No**
 Offset Jamb **No Offset**
 Jamb Applied **Yes**
 Installation Clips **None**
 Kolbe Installation Consulting **No**

*** Performance ***

Performance **Standard Performance**
 Unit Type **Complete Unit**
 Unit Package **No Package**
 Model **Push Out**
 Production **Current**
 Hinging **Left - Right**
 Sash Material **Extruded**

*** Unit ***

*** Glass ***

Glass Make Up **Double Glazed**
 Glass **Solar Low-E**
 Glass Spacer **Mill Finish**
 High Altitude **No**
 Glass Preserve / Neat+ Coating **Glass Preserve without Neat+ Coating**
 Glazing Bead **Ovolo**
 Left Glass - Glass Type **Clear**
 Left Glass - Obscure / Opaque Glass **None**
 Left Glass **NOT Tempered**
 Right Glass - Glass Type **Clear**
 Right Glass - Obscure / Opaque Glass **None**
 Right Glass **NOT Tempered**

*** Lite Divisions - Left ***

Lite Division **Performance Divided Lites**
 Bar Profile - Exterior **Beveled**
 Bar Profile - Interior **Ovolo**
 Bar Size **5/8"**
 Internal Spacers **Champagne**
 Second Bar Size **None**
 Grid Pattern **Colonial**
 Colonial Divison **2W3H**
 Grille Division Type **Specified**



Printed By: Steve Davis

Created: 5/26/2023

This report does not include Non-Kolbe Items

2023 Pricing

Window and Door Details Page 27 of 76

For warranty information please click this link or visit <https://www.kolbewindows.com/resources/warranties>

Window and Door Details

*** Lite Divisions - Right ***

Lite Division	Performance Divided Lites
Bar Profile - Exterior	Beveled
Bar Profile - Interior	Ovolo
Bar Size	5/8"
Internal Spacers	Champagne
Second Bar Size	None
Grid Pattern	Colonial
Colonial Division	2W3H
Grille Division Type	Specified
Lite Bar Alignment	Align Horizontal

*** Hardware-Accessories ***

Window Hardware	Multi-Point Lock
Hardware Color	Natural Brass
Screen	Retractable Screen
Retractable Screen with Recessed Head Location	No
Retractable Screen Side Cover	Beveled
Mesh Type	BetterVue Fiberglass
Screen(s) Applied	Yes

*** Species-Finish-Color ***

Change Species	Leave All Pine
Exterior Frame Finish	70% Fluoropolymer
Exterior Sash Finish	70% Fluoropolymer
Match All Exterior Colors	Yes
Exterior Color	Ultra Pure White
Interior Frame Finish	Colored Prefinish
Interior Sash Finish	Colored Prefinish
Match All Interior Colors	Yes
Interior Color	Ultra Pure White
Screen Color	White Channel with Black Weatherstrip
Screen Finish	Colored Prefinish
Screen Finish Color	Ultra Pure White
Fingerjoints	Standard Fingerjoints



WINDOW 7

Quote 1217694C: 45 W LENOX STREET

Merit Commercial Windows, Inc

6/19/2023 3:31:55 PM

002 BAR FRONT

EA

(1)

12.37

\$4,883.25

\$4,883.25

*** Unit ***

UFC (Assy 1)

Ultra Rectangle French Casement

*** Unit ***

Unit 1.1: Extruded Sash, Push Out, Left - Right Hinging

*** Glass ***

Unit 1.1: Solar Low-E Glass

*** Lite Divisions ***

Unit 1.1 Left: Performance Divided Lites, Colonial, 2W3H, 5/8" Bars, Beveled Bars - Exterior

Unit 1.1 Right: Performance Divided Lites, Colonial, Align Horizontal Bars, 2W3H, 5/8" Bars, Beveled Bars - Exterior

*** Hardware-Accessories ***

Unit 1.1: Multi-Point Lock Window Hardware, Natural Brass Hardware, BetterVue Fiberglass Retractable Screen

*** Species-Finish-Color ***

Unit 1.1: 70% Fluoropolymer Exterior Sash, 70% Fluoropolymer Exterior Frame, Ultra Pure White Exterior, Colored Prefinish Interior Sash, Colored Prefinish Interior Frame, Ultra Pure White Interior, White Screen Channel with Black Weatherstrip, Ultra Pure White Colored Prefinish Screen

*** Casing-Jambs-Trim ***

Unit 1.1: No Casing, No Sill Nosing, No Nailing Fin, 4-9/16" Jambs

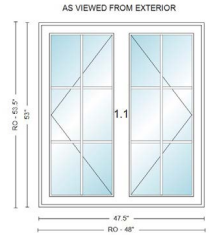

Scaled to Fit

Rough Opening:
48" X 53 1/2"

Frame Size:
47 1/2" X 53"

Unit Dimension:
47 1/2" X 53"



Printed By: Steve Davis

Created: 5/26/2023

* Indicates Increased Rough Opening

2023 Pricing

Summary Page 3 of 76

For warranty information please click this link or visit <https://www.kolbewindows.com/resources/warranties>

WINDOW 8

THIS DRAWING AND THE INFORMATION IT CONTAINS ARE THE PROPERTY OF KOLBE & KOLBE MILLWORK CO., INC. AND ARE PROPRIETARY AND CONFIDENTIAL TO KOLBE & KOLBE MILLWORK CO., INC. ANY UNAUTHORIZED PUBLICATION, COPYING, USE, REPRODUCTION, DISCLOSURE OR DISSEMINATION OF THE DRAWING OR INFORMATION BY ANY MEANS (INCLUDING ELECTRONIC MEANS) IS PROHIBITED.

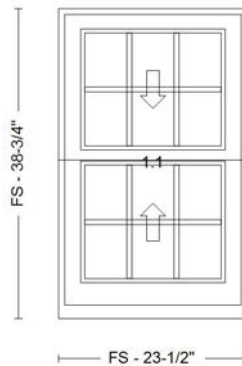

FS: 23-1/2" X 38-3/4"

RO: 24" X 39-5/16"

UD: 23-1/2" X 38-3/4"

Ultra Rectangle Double Hung
UDH (Assy 1)

NOT FOR PRODUCTION USE

CUSTOMER: MERIT COMMERCIAL WINDOWS, INC	LINE: 005-1	QUANTITY: 1
PRINTED BY: STEVE DAVIS	LABEL: FRONT-POWDER ROOM	
PROJECT: 45 W LENOX STREET		
QUOTE 1217694: 45 W LENOX STREET	PK VERSION: 759	
PRINTED: 6/19/2023 3:34 PM		

Window and Door Details

Line Number **005-1**
 Label **FRONT-POWDER ROOM**
 Product Name **Ultra Rectangle Double Hung (UDH)**
 Configured in PK Version **759**

Scaled To Fit

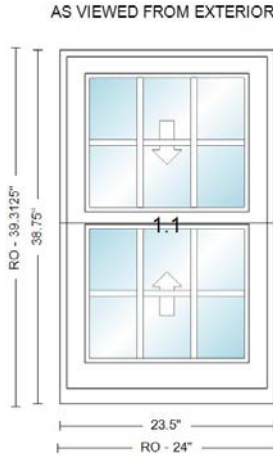

Quantity **(1)**
 Cubic Feet **3.99**
 Unit Price **\$2,054.58**
 Extended Price **\$2,054.58**

*** Pricing Details ***

Base Price **\$791.38**
 Lower Glass PDL **\$245.25**
 Upper Glass PDL **\$245.25**
 Screen **\$36.15**
 Non-Standard Size **\$265.13**
 Hardware Color **\$54.03**
 Lower Glass Glass **\$4.32**
 Upper Glass Glass **\$4.32**
 Screen Prep **\$34.15**
 Interior Finish **\$199.85**
 Lower Glass Lite Finish **\$87.37**
 Upper Glass Lite Finish **\$87.37**

*** Overall Dimensions ***

Overall Frame Width **23 1/2"**
 Overall Frame Height **38 3/4"**
 Overall Rough Opening Width **24"**
 Overall Rough Opening Height **39 5/16"**
 Overall Unit Dimension Width **23 1/2"**
 Overall Unit Dimension Height **38 3/4"**

*** Dimensions ***

Call Width **Custom**
 Call Height **Custom**
 Individual Frame Width **23 1/2"**
 Individual Frame Height **38 3/4"**
 Clear Opening Width **19 31/32"**
 Clear Opening Height **13 17/32"**

Glass Width **18"**
 Glass Height **15 5/32"**

*** Casing-Jamb-Trim ***

Exterior Casing/Accessories **No Casing**
 Sill Nosing **No Sill Nosing**
 Nailing Fin **No**
 Back Priming of Frame **No**
 Jamb Depth **4 9/16"**
 Installation Clips **None**
 Kolbe Installation Consulting **No**

*** Performance ***

Performance **Standard Performance**

*** Unit ***

Unit Type **Complete Unit**
 Unit Package **No Package**
 Model **Sterling**
 Production **Current**
 Vintage **#1117**
 Sash Material **Extruded**
 Basic Jamb Profile **Square**

*** Glass ***

Glass Make Up **Double Glazed**
 Glass **Solar Low-E**
 Glass Spacer **Mill Finish**
 High Altitude **No**
 Glass Preserve / Neat+ Coating **Glass Preserve without Neat+ Coating**
 Glazing Bead **Ovolo**
 Upper Glass - Glass Type **Clear**
 Upper Glass - Obscure / Opaque Glass **None**
 Upper Glass **NOT Tempered**
 Lower Glass - Glass Type **Clear**
 Lower Glass - Obscure / Opaque Glass **None**
 Lower Glass **NOT Tempered**

*** Lite Divisions - Upper ***

Lite Division **Performance Divided Lites**
 Bar Profile - Exterior **Beveled**
 Bar Profile - Interior **Ovolo**
 Bar Size **5/8"**
 Internal Spacers **Champagne**
 Second Bar Size **None**
 Grid Pattern **Colonial**
 Colonial Division **3W2H**
 Grille Division Type **Specified**

*** Lite Divisions - Lower ***

Lite Division **Performance Divided Lites**
 Bar Profile - Exterior **Beveled**
 Bar Profile - Interior **Ovolo**
 Bar Size **5/8"**
 Internal Spacers **Champagne**



WINDOW 8

Quote 1217694C: 45 W LENOX STREET

Merit Commercial Windows, Inc

6/19/2023 3:31:55 PM

Window and Door Details

Second Bar Size	None
Grid Pattern	Colonial
Colonial Divison	3W2H
Grille Division Type	Specified
Lite Bar Alignment	Align Vertical

*** Hardware-Accessories ***

Lock Style	Spoon
Hardware Color	Antique Brass
Bottom Sash Lift Handle(s)	No
Screen	Half Screen
Mesh Type	BetterVue Fiberglass
Screen(s) Applied	No
Ogee Lugs	No
Jambliner	Black
Window Opening Control Device	No
Class 5 Balance	No

*** Species-Finish-Color ***

Change Species	Leave All Pine
Exterior Frame Finish	70% Fluoropolymer
Exterior Sash Finish	70% Fluoropolymer
Match All Exterior Colors	Yes
Exterior Color	Ultra Pure White
Interior Frame Finish	Colored Prefinish
Interior Sash Finish	Colored Prefinish
Match All Interior Colors	Yes
Interior Color	Ultra Pure White
Jambliner Cover	Wood Wrapped
Vertical Weatherstrip Color	Black
Fingerjoints	Standard Fingerjoints



Printed By: Steve Davis

Created: 5/26/2023

This report does not include Non-Kolbe Items

2023 Pricing

Window and Door Details Page 34 of 76

For warranty information please click this link or visit <https://www.kolbewindows.com/resources/warranties>

WINDOW 8

005 FRONT-POWDER ROOM EA (1) 3.99 \$2,054.58 \$2,054.58

*** Unit ***
UDH (Assy 1)

Ultra Rectangle Double Hung

*** Unit ***
Unit 1.1: #1117 Vintage, Extruded Sash, Sterling, Square Basic Jamb Profile

*** Glass ***
Unit 1.1: Solar Low-E Glass

*** Lite Divisions ***
Unit 1.1 Lower: Performance Divided Lites, Colonial, Align Vertical Bars, 3W2H, 5/8" Bars, Beveled Bars - Exterior

Unit 1.1 Upper: Performance Divided Lites, Colonial, 3W2H, 5/8" Bars, Beveled Bars - Exterior

*** Hardware-Accessories ***
Unit 1.1: Antique Brass Hardware, Spoon Lock, BetterVue Fiberglass Half Screen, Screen(s) Loose

*** Species-Finish-Color ***
Unit 1.1: 70% Fluoropolymer Exterior Sash, 70% Fluoropolymer Exterior Frame, Ultra Pure White Exterior, Colored Prefinish Interior Sash, Colored Prefinish Interior Frame, Ultra Pure White Interior, Wood Wrapped Jambliner, Black Vertical Weatherstrip

*** Casing-Jambs-Trim ***
Unit 1.1: No Casing, No Sill Nosing, No Nailing Fin, 4-9/16" Jambs

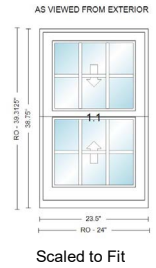

**Rough Opening:
24" X 39 5/16"**

**Frame Size:
23 1/2" X 38 3/4"**

**Unit Dimension:
23 1/2" X 38 3/4"**

006 REAR DINING ROOM-FULL REPLACEMENT EA (1) 42.16 \$3,513.91 \$3,513.91

*** Unit ***
UTR (Assy 1)

Ultra Rectangle DH/SH Transom

*** Unit ***
Unit 1.1: Match Sterling Profile, Direct Set

*** Glass ***
Unit 1.1: Solar Low-E Glass

Unit 1.1: Tempered Glass

*** Species-Finish-Color ***
Unit 1.1: Ultra Pure White 70% Fluoropolymer Exterior Frame, Colored Prefinish Interior Frame

*** Casing-Jambs-Trim ***
Unit 1.1: No Casing, No Sill Nosing, No Nailing Fin, 4-9/16" Jambs

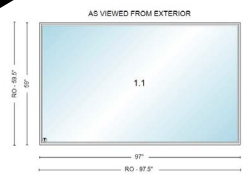

**Rough Opening:
97 1/2" X 59 1/2"**

**Frame Size:
97" X 59"**

**Unit Dimension:
97" X 59"**

will be posted later in proper order



DOOR- LABELED 9

THIS DRAWING AND THE INFORMATION IT CONTAINS ARE THE PROPERTY OF KOLBE & KOLBE MILLWORK CO., INC. AND ARE PROPRIETARY AND CONFIDENTIAL TO KOLBE & KOLBE MILLWORK CO., INC. ANY UNAUTHORIZED PUBLICATION, COPYING, USE, REPRODUCTION, DISCLOSURE OR DISSEMINATION OF THE DRAWING OR INFORMATION BY ANY MEANS (INCLUDING ELECTRONIC MEANS) IS PROHIBITED.

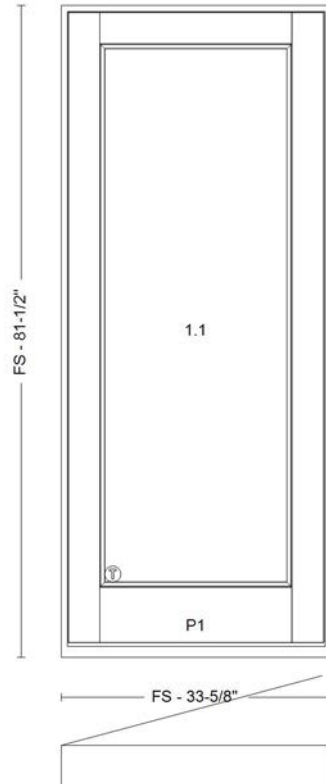

FS: 33-5/8" X 81-1/2"

RO: 34-1/8" X 82"

UD: 33-5/8" X 81-1/2"

Ultra Rectangle Exterior Swinging Door
UXD (Assy 1)

NOT FOR PRODUCTION USE

CUSTOMER: MERIT COMMERCIAL WINDOWS, INC	LINE: 026-1	QUANTITY: 1
PRINTED BY: STEVE DAVIS	LABEL: KITCHEN FRONT	
PROJECT: 45 W LENOX STREET		
QUOTE 1217694: 45 W LENOX STREET	PK VERSION: 759	
PRINTED: 6/19/2023 3:34 PM		

DOOR- LABLED 9

Quote 1217694C: 45 W LENOX STREET

Merit Commercial Windows, Inc

6/19/2023 3:31:55 PM

Window and Door Details

Line Number **026-1**
 Label **KITCHEN FRONT**
 Product Name **Ultra Rectangle Exterior Swinging Door (UXD)**
 Configured in PK Version **759**

Scaled To Fit

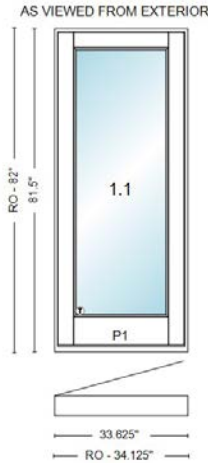

Quantity **(1)**
 Cubic Feet **11.58**
 Unit Price **\$4,023.58**
 Extended Price **\$4,023.58**

*** Pricing Details ***

Frame **\$973.16**
 Panel **\$1,240.30**
 Glass **\$16.32**
 Hardware **\$530.16**
 Keyed Alike **\$51.22**
 Hinges **\$192.82**
 Non-Standard Size Panel **\$251.07**
 Non-Standard Size Frame **\$66.28**
 Interior Finish **\$438.87**
 Strike Color **\$151.90**
 Multi-Pt Special Height **\$111.48**

*** Overall Dimensions ***

Overall Frame Width **33 5/8"**
 Overall Frame Height **81 1/2"**
 Overall Rough Opening Width **34 1/8"**
 Overall Rough Opening Height **82"**
 Overall Unit Dimension Width **33 5/8"**
 Overall Unit Dimension Height **81 1/2"**

*** Dimensions ***

Call Width **2-8**
 Call Height **Custom**
 Individual Frame Width **33 5/8"**
 Individual Frame Height **81 1/2"**
 Clear Opening Width **29 1/8"**
 Clear Opening Height **78 11/32"**
 Slab Width **31 13/16"**

Slab Height **78 25/32"**
 Glass Width **23 11/16"**
 Glass Height **67 11/16"**

*** Casing-Jamb-Trim ***

Door Sill Aluminum
 Door Sill Color Dark Bronze Anodized
 Exterior Casing/Accessories No Casing
 Extended Horns No
 Nailing Fin No
 Back Priming of Frame No
 Jamb Depth **4 9/16"**
 Modern Trim Extension Jamb No
 Installation Clips None
 Kolbe Installation Consulting No

*** Performance ***

Performance Standard Performance

*** Unit ***

Unit Type Complete Unit
 Model Ultra
 Production Current
 Operation Inswing
 Hinging (As Door Pulls Towards You) Right
 Sash Material Extruded
 Panel Style Full Lite
 Panel Thickness 1 3/4"
 Frame Thickness 1 3/4"

*** Glass ***

Glass Make Up Double Glazed
 Glass Solar Low-E
 Glass Spacer Mill Finish
 High Altitude No
 Glass Preserve / Neat+ Coating Glass Preserve without Neat+ Coating
 Glazing Bead Ovolio
 Glass Type Clear
 Obscure / Opaque Glass None
 Tempered

*** Hardware-Accessories ***

Door Hardware Multi-Point Lock
 Multi-Point Type European Style-Deadbolt on Bottom
 Door Handle Type Toronto
 Hardware Color Antique Brass
 Keyed Alike Keyed Alike Across Product Lines
 Door Strike Color Antique Brass
 Lock Height **Standard Lock Height**
 Backset 45 mm
 Hinge Type Adjustable Hinges
 Hinge Color Antique Brass
 Screen No Screen - No Prep
 Include Construction Door Panel No



Printed By: Steve Davis

Created: 5/26/2023

This report does not include Non-Kolbe Items

2023 Pricing

Window and Door Details Page 74 of 76

For warranty information please click this link or visit <https://www.kolbewindows.com/resources/warranties>

DOOR- LABLED 9

Quote 1217694C: 45 W LENOX STREET

Merit Commercial Windows, Inc

6/19/2023 3:31:55 PM

Window and Door Details

*** Species-Finish-Color ***

Change Species	Leave All Pine
Exterior Frame Finish	70% Fluoropolymer
Exterior Sash Finish	70% Fluoropolymer
Match All Exterior Colors	Yes
Exterior Color	Ultra Pure White
Interior Frame Finish	Colored Prefinish
Interior Sash Finish	Colored Prefinish
Match All Interior Colors	Yes
Interior Color	Ultra Pure White
Weatherstrip Color	Black
Fingerjoints	Standard Fingerjoints



Printed By: Steve Davis

Created: 5/26/2023

This report does not include Non-Kolbe Items

2023 Pricing

Window and Door Details Page 75 of 76

For warranty information please click this link or visit <https://www.kolbewindows.com/resources/warranties>

025 KITCHEN REAR EA (1) 13.00 \$4,933.17 \$4,933.17

*** Unit ***
UXD (Assy 1)

Ultra Rectangle Exterior Swinging Door

*** Unit ***
Unit 1.1: Extruded Sash, Ultra, Outswing, Left Hinging, Full Lite Panel Style

*** Glass ***
Unit 1.1: Solar Low-E Glass

Unit 1.1: Tempered Glass

*** Hardware-Accessories ***
Unit 1.1: Multi-Point Lock Door Hardware, European Style-Deadbolt on Bottom, Antique Brass Hardware, 45 mm Backset, Standard Lock Height, Antique Brass Hinges

*** Species-Finish-Color ***
Unit 1.1: 70% Fluoropolymer Exterior Sash, 70% Fluoropolymer Exterior Frame, Ultra Pure White Exterior, Colored Prefinish Interior Sash, Colored Prefinish Interior Frame, Ultra Pure White Interior

*** Casing-Jambs-Trim ***
Unit 1.1: No Casing, No Nailing Fin, 4-9/16" Jambs

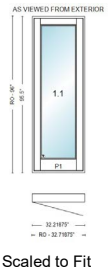

Rough Opening:
32 23/32" X 96"

Frame Size:
32 7/32" X 95 1/2"

Unit Dimension:
32 7/32" X 95 1/2"

026 KITCHEN FRONT EA (1) 11.58 \$4,023.58 \$4,023.58

**DOOR-
LABLED 9**

*** Unit ***
UXD (Assy 1)

Ultra Rectangle Exterior Swinging Door

*** Unit ***
Unit 1.1: Extruded Sash, Ultra, Inswing, Right Hinging, Full Lite Panel Style

*** Glass ***
Unit 1.1: Solar Low-E Glass

Unit 1.1: Tempered Glass

*** Hardware-Accessories ***
Unit 1.1: Multi-Point Lock Door Hardware, European Style-Deadbolt on Bottom, Antique Brass Hardware, 45 mm Backset, Standard Lock Height, Antique Brass Hinges

*** Species-Finish-Color ***
Unit 1.1: 70% Fluoropolymer Exterior Sash, 70% Fluoropolymer Exterior Frame, Ultra Pure White Exterior, Colored Prefinish Interior Sash, Colored Prefinish Interior Frame, Ultra Pure White Interior

*** Casing-Jambs-Trim ***
Unit 1.1: No Casing, No Nailing Fin, 4-9/16" Jambs

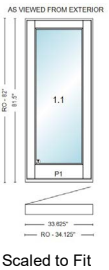

Rough Opening:
34 1/8" X 82"

Frame Size:
33 5/8" X 81 1/2"

Unit Dimension:
33 5/8" X 81 1/2"



WINDOW 10

THIS DRAWING AND THE INFORMATION IT CONTAINS ARE THE PROPERTY OF KOLBE & KOLBE MILLWORK CO., INC. AND ARE PROPRIETARY AND CONFIDENTIAL TO KOLBE & KOLBE MILLWORK CO., INC. ANY UNAUTHORIZED PUBLICATION, COPYING, USE, REPRODUCTION, DISCLOSURE OR DISSEMINATION OF THE DRAWING OR INFORMATION BY ANY MEANS (INCLUDING ELECTRONIC MEANS) IS PROHIBITED.

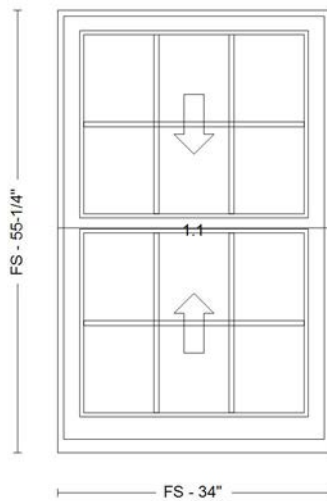

FS: 34" X 55-1/4"
 RO: 34-1/2" X 55-13/16"
 UD: 34" X 55-1/4"

Ultra Rectangle Double Hung
 UDH (Assy 1)

NOT FOR PRODUCTION USE

CUSTOMER: MERIT COMMERCIAL WINDOWS, INC	LINE: 009-1	QUANTITY: 1
PRINTED BY: STEVE DAVIS	LABEL: FRONT LEFT BEDROOM	
PROJECT: 45 W LENOX STREET		
QUOTE 1217694: 45 W LENOX STREET	PK VERSION: 759	
PRINTED: 6/19/2023 3:34 PM		

Window and Door Details

Line Number **009-1**
 Label **FRONT LEFT BEDROOM**
 Product Name **Ultra Rectangle Double Hung (UDH)**
 Configured in PK Version **759**

Scaled To Fit

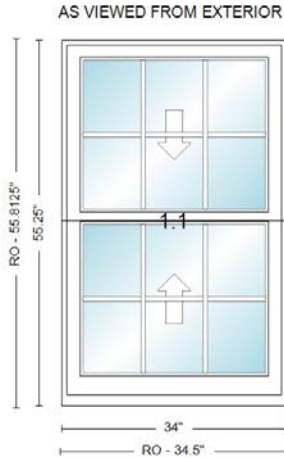

Quantity **(1)**
 Cubic Feet **9.23**
 Unit Price **\$2,381.28**
 Extended Price **\$2,381.28**

*** Pricing Details ***

Base Price **\$1,011.32**
 Lower Glass PDL **\$245.25**
 Upper Glass PDL **\$245.25**
 Screen **\$50.21**
 Non-Standard Size **\$265.13**
 Hardware Color **\$54.03**
 Lower Glass Glass **\$6.98**
 Upper Glass Glass **\$6.98**
 Screen Prep **\$34.15**
 Interior Finish **\$287.23**
 Lower Glass Lite Finish **\$87.37**
 Upper Glass Lite Finish **\$87.37**

*** Overall Dimensions ***

Overall Frame Width **34"**
 Overall Frame Height **55 1/4"**
 Overall Rough Opening Width **34 1/2"**
 Overall Rough Opening Height **55 13/16"**
 Overall Unit Dimension Width **34"**
 Overall Unit Dimension Height **55 1/4"**

*** Dimensions ***

Call Width **Custom**
 Call Height **Custom**
 Individual Frame Width **34"**
 Individual Frame Height **55 1/4"**
 Clear Opening Width **30 15/32"**
 Clear Opening Height **21 25/32"**

Glass Width **28 1/2"**
 Glass Height **23 13/32"**

*** Casing-Jamb-Trim ***

Exterior Casing/Accessories **No Casing**
 Sill Nosing **No Sill Nosing**
 Nailing Fin **No**
 Back Priming of Frame **No**
 Jamb Depth **4 9/16"**
 Installation Clips **None**
 Kolbe Installation Consulting **No**

*** Performance ***

Performance **Standard Performance**

*** Unit ***

Unit Type **Complete Unit**
 Unit Package **No Package**
 Model **Sterling**
 Production **Current**
 Vintage **#1117**
 Sash Material **Extruded**
 Basic Jamb Profile **Square**

*** Glass ***

Glass Make Up **Double Glazed**
 Glass **Solar Low-E**
 Glass Spacer **Mill Finish**
 High Altitude **No**
 Glass Preserve / Neat+ Coating **Glass Preserve without Neat+ Coating**
 Glazing Bead **Ovolo**
 Upper Glass - Glass Type **Clear**
 Upper Glass - Obscure / Opaque Glass **None**
 Upper Glass **NOT Tempered**
 Lower Glass - Glass Type **Clear**
 Lower Glass - Obscure / Opaque Glass **None**
 Lower Glass **NOT Tempered**

*** Lite Divisions - Upper ***

Lite Division **Performance Divided Lites**
 Bar Profile - Exterior **Beveled**
 Bar Profile - Interior **Ovolo**
 Bar Size **5/8"**
 Internal Spacers **Champagne**
 Second Bar Size **None**
 Grid Pattern **Colonial**
 Colonial Division **3W2H**
 Grille Division Type **Specified**

*** Lite Divisions - Lower ***

Lite Division **Performance Divided Lites**
 Bar Profile - Exterior **Beveled**
 Bar Profile - Interior **Ovolo**
 Bar Size **5/8"**
 Internal Spacers **Champagne**



Window and Door Details

Second Bar Size	None
Grid Pattern	Colonial
Colonial Divison	3W2H
Grille Division Type	Specified
Lite Bar Alignment	Align Vertical

*** Hardware-Accessories ***

Lock Style	Spoon
Hardware Color	Antique Brass
Bottom Sash Lift Handle(s)	No
Screen	Half Screen
Mesh Type	BetterVue Fiberglass
Screen(s) Applied	No
Ogee Lugs	No
Jambliner	Black
Window Opening Control Device	No
Class 5 Balance	No

*** Species-Finish-Color ***

Change Species	Leave All Pine
Exterior Frame Finish	70% Fluoropolymer
Exterior Sash Finish	70% Fluoropolymer
Match All Exterior Colors	Yes
Exterior Color	Ultra Pure White
Interior Frame Finish	Colored Prefinish
Interior Sash Finish	Colored Prefinish
Match All Interior Colors	Yes
Interior Color	Ultra Pure White
Jambliner Cover	Wood Wrapped
Vertical Weatherstrip Color	Black
Fingerjoints	Standard Fingerjoints



WINDOW 10

Quote 1217694C: 45 W LENOX STREET

Merit Commercial Windows, Inc

6/19/2023 3:31:55 PM

009 FRONT LEFT BEDROOM EA (1) 9.23 \$2,381.28 \$2,381.28

*** Unit ***

UDH (Assy 1)

Ultra Rectangle Double Hung

*** Unit ***

Unit 1.1: #1117 Vintage, Extruded Sash, Sterling, Square Basic Jamb Profile

*** Glass ***

Unit 1.1: Solar Low-E Glass

*** Lite Divisions ***

Unit 1.1 Lower: Performance Divided Lites, Colonial, Align Vertical Bars, 3W2H, 5/8" Bars, Beveled Bars - Exterior

Unit 1.1 Upper: Performance Divided Lites, Colonial, 3W2H, 5/8" Bars, Beveled Bars - Exterior

*** Hardware-Accessories ***

Unit 1.1: Antique Brass Hardware, Spoon Lock, BetterVue Fiberglass Half Screen, Screen(s) Loose

*** Species-Finish-Color ***

Unit 1.1: 70% Fluoropolymer Exterior Sash, 70% Fluoropolymer Exterior Frame, Ultra Pure White Exterior, Colored Prefinish Interior Sash, Colored Prefinish Interior Frame, Ultra Pure White Interior, Wood Wrapped Jambliner, Black Vertical Weatherstrip

*** Casing-Jambs-Trim ***

Unit 1.1: No Casing, No Sill Nosing, No Nailing Fin, 4-9/16" Jambs

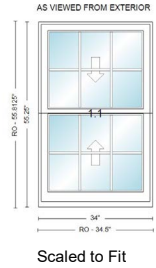

Rough Opening:
34 1/2" X 55 13/16"

Frame Size:
34" X 55 1/4"

Unit Dimension:
34" X 55 1/4"



Printed By: Steve Davis

Created: 5/26/2023

* Indicates Increased Rough Opening

2023 Pricing

Summary Page 9 of 76

For warranty information please click this link or visit <https://www.kolbewindows.com/resources/warranties>

WINDOW 11 AND 12

THIS DRAWING AND THE INFORMATION IT CONTAINS ARE THE PROPERTY OF KOLBE & KOLBE MILLWORK CO., INC. AND ARE PROPRIETARY AND CONFIDENTIAL TO KOLBE & KOLBE MILLWORK CO., INC. ANY UNAUTHORIZED PUBLICATION, COPYING, USE, REPRODUCTION, DISCLOSURE OR DISSEMINATION OF THE DRAWING OR INFORMATION BY ANY MEANS (INCLUDING ELECTRONIC MEANS) IS PROHIBITED.

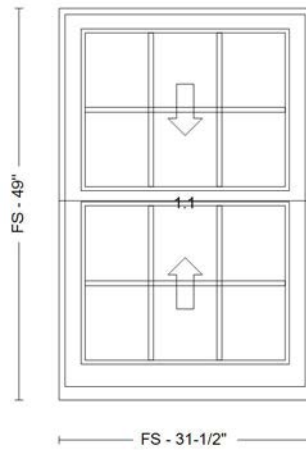

FS: 31-1/2" X 49"
 RO: 32" X 49-9/16"
 UD: 31-1/2" X 49"

Ultra Rectangle Double Hung
 UDH (Assy 1)

NOT FOR PRODUCTION USE

CUSTOMER: MERIT COMMERCIAL WINDOWS, INC	LINE: 018-1	QUANTITY: 1
PRINTED BY: STEVE DAVIS	LABEL: 3RD FLOOR LEFT BED-REAR	
PROJECT: 45 W LENOX STREET		
QUOTE 1217694: 45 W LENOX STREET	PK VERSION: 759	
PRINTED: 6/19/2023 3:34 PM		

WINDOW 11 AND 12

Quote 1217694C: 45 W LENOX STREET

Merit Commercial Windows, Inc

6/19/2023 3:31:55 PM

Window and Door Details

Line Number **020-1**
 Label **3RD FL RIGHT BED**
 Product Name **Ultra Rectangle Double Hung (UDH)**
 Configured in PK Version **759**

Scaled To Fit

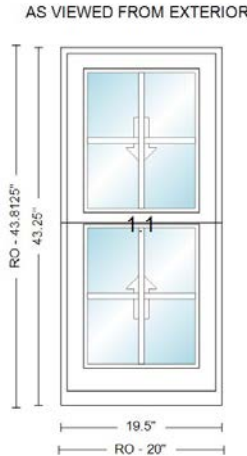

Quantity **(2)**
 Cubic Feet **3.7**
 Unit Price **\$1,834.84**
 Extended Price **\$3,669.68**

*** Pricing Details ***

Base Price **\$793.39**
 Lower Glass PDL **\$163.50**
 Upper Glass PDL **\$163.50**
 Screen **\$34.15**
 Non-Standard Size **\$265.13**
 Hardware Color **\$54.03**
 Lower Glass Glass **\$4.32**
 Upper Glass Glass **\$4.32**
 Screen Prep **\$34.15**
 Interior Finish **\$201.86**
 Lower Glass Lite Finish **\$58.25**
 Upper Glass Lite Finish **\$58.25**

*** Overall Dimensions ***

Overall Frame Width **19 1/2"**
 Overall Frame Height **43 1/4"**
 Overall Rough Opening Width **20"**
 Overall Rough Opening Height **43 13/16"**
 Overall Unit Dimension Width **19 1/2"**
 Overall Unit Dimension Height **43 1/4"**

*** Dimensions ***

Call Width **Custom**
 Call Height **Custom**
 Individual Frame Width **19 1/2"**
 Individual Frame Height **43 1/4"**
 Clear Opening Width **15 31/32"**
 Clear Opening Height **15 25/32"**

Glass Width **14"**
 Glass Height **17 13/32"**

*** Casing-Jamb-Trim ***

Exterior Casing/Accessories **No Casing**
 Sill Nosing **No Sill Nosing**
 Nailing Fin **No**
 Back Priming of Frame **No**
 Jamb Depth **4 9/16"**
 Installation Clips **None**
 Kolbe Installation Consulting **No**

*** Performance ***

Performance **Standard Performance**

*** Unit ***

Unit Type **Complete Unit**
 Unit Package **No Package**
 Model **Sterling**
 Production **Current**
 Vintage **#1117**
 Sash Material **Extruded**
 Basic Jamb Profile **Square**

*** Glass ***

Glass Make Up **Double Glazed**
 Glass **Solar Low-E**
 Glass Spacer **Mill Finish**
 High Altitude **No**
 Glass Preserve / Neat+ Coating **Glass Preserve without Neat+ Coating**
 Glazing Bead **Ovolo**
 Upper Glass - Glass Type **Clear**
 Upper Glass - Obscure / Opaque Glass **None**
 Upper Glass **NOT Tempered**
 Lower Glass - Glass Type **Clear**
 Lower Glass - Obscure / Opaque Glass **None**
 Lower Glass **NOT Tempered**

*** Lite Divisions - Upper ***

Lite Division **Performance Divided Lites**
 Bar Profile - Exterior **Beveled**
 Bar Profile - Interior **Ovolo**
 Bar Size **5/8"**
 Internal Spacers **Champagne**
 Second Bar Size **None**
 Grid Pattern **Colonial**
 Colonial Division **2W2H**
 Grille Division Type **Specified**

*** Lite Divisions - Lower ***

Lite Division **Performance Divided Lites**
 Bar Profile - Exterior **Beveled**
 Bar Profile - Interior **Ovolo**
 Bar Size **5/8"**
 Internal Spacers **Champagne**



Printed By: Steve Davis

Created: 5/26/2023

This report does not include Non-Kolbe Items

2023 Pricing

Window and Door Details Page 62 of 76

For warranty information please click this link or visit <https://www.kolbewindows.com/resources/warranties>

WINDOW 11 AND 12

Quote 1217694C: 45 W LENOX STREET

Merit Commercial Windows, Inc

6/19/2023 3:31:55 PM

Window and Door Details

Second Bar Size	None
Grid Pattern	Colonial
Colonial Divison	2W2H
Grille Division Type	Specified
Lite Bar Alignment	Align Vertical

*** Hardware-Accessories ***

Lock Style	Spoon
Hardware Color	Antique Brass
Bottom Sash Lift Handle(s)	No
Screen	Half Screen
Mesh Type	BetterVue Fiberglass
Screen(s) Applied	No
Ogee Lugs	No
Jambliner	Black
Window Opening Control Device	No
Class 5 Balance	No

*** Species-Finish-Color ***

Change Species	Leave All Pine
Exterior Frame Finish	70% Fluoropolymer
Exterior Sash Finish	70% Fluoropolymer
Match All Exterior Colors	Yes
Exterior Color	Ultra Pure White
Interior Frame Finish	Colored Prefinish
Interior Sash Finish	Colored Prefinish
Match All Interior Colors	Yes
Interior Color	Ultra Pure White
Jambliner Cover	Wood Wrapped
Vertical Weatherstrip Color	Black
Fingerjoints	Standard Fingerjoints



Printed By: Steve Davis

Created: 5/26/2023

This report does not include Non-Kolbe Items

2023 Pricing

Window and Door Details Page 63 of 76

For warranty information please click this link or visit <https://www.kolbewindows.com/resources/warranties>

WINDOW 11 AND 12

017 3RD FLOOR LEFT BED EA (2) 6.64 \$2,195.78 \$4,391.56

*** Unit ***

UDH (Assy 1)

Ultra Rectangle Double Hung

*** Unit ***

Unit 1.1: #1117 Vintage, Extruded Sash, Sterling, Square Basic Jamb Profile

*** Glass ***

Unit 1.1: Solar Low-E Glass

*** Lite Divisions ***

Unit 1.1 Lower: Performance Divided Lites, Colonial, Align Vertical Bars, 3W2H, 5/8" Bars, Beveled Bars - Exterior

Unit 1.1 Upper: Performance Divided Lites, Colonial, 3W2H, 5/8" Bars, Beveled Bars - Exterior

*** Hardware-Accessories ***

Unit 1.1: Antique Brass Hardware, Spoon Lock, BetterVue Fiberglass Half Screen, Screen(s) Loose

*** Species-Finish-Color ***

Unit 1.1: 70% Fluoropolymer Exterior Sash, 70% Fluoropolymer Exterior Frame, Ultra Pure White Exterior, Colored Prefinish Interior Sash, Colored Prefinish Interior Frame, Ultra Pure White Interior, Wood Wrapped Jambliner, Black Vertical Weatherstrip

*** Casing-Jambs-Trim ***

Unit 1.1: No Casing, No Sill Nosing, No Nailing Fin, 4-9/16" Jambs

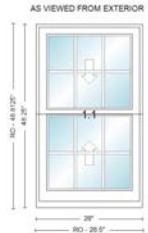

Scaled to Fit

Rough Opening:
28 1/2" X 48 13/16"

Frame Size:
28" X 48 1/4"

Unit Dimension:
28" X 48 1/4"



WINDOW 13, 14, 15, 16, 17, 18, 19

THIS DRAWING AND THE INFORMATION IT CONTAINS ARE THE PROPERTY OF KOLBE & KOLBE MILLWORK CO., INC. AND ARE PROPRIETARY AND CONFIDENTIAL TO KOLBE & KOLBE MILLWORK CO., INC. ANY UNAUTHORIZED PUBLICATION, COPYING, USE, REPRODUCTION, DISCLOSURE OR DISSEMINATION OF THE DRAWING OR INFORMATION BY ANY MEANS (INCLUDING ELECTRONIC MEANS) IS PROHIBITED.

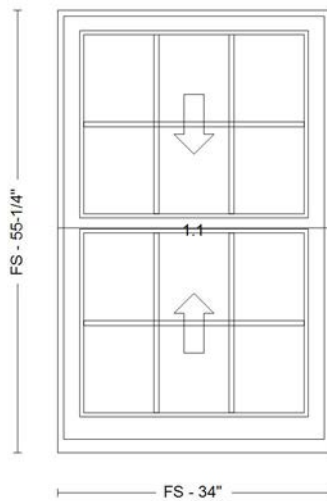

FS: 34" X 55-1/4"
 RO: 34-1/2" X 55-13/16"
 UD: 34" X 55-1/4"

Ultra Rectangle Double Hung
 UDH (Assy 1)

NOT FOR PRODUCTION USE

CUSTOMER: MERIT COMMERCIAL WINDOWS, INC	LINE: 011-1	QUANTITY: 2
PRINTED BY: STEVE DAVIS	LABEL: REAR LEFT BEDROOM	
PROJECT: 45 W LENOX STREET		
QUOTE 1217694: 45 W LENOX STREET	PK VERSION: 759	
PRINTED: 6/19/2023 3:34 PM		

WINDOW 13, 14, 15, 16, 17, 18, 19

Quote 1217694C: 45 W LENOX STREET

Merit Commercial Windows, Inc

6/19/2023 3:31:55 PM

Window and Door Details

Line Number 010-1
Label FRONT, SIDE, REAR-OFFICE
Product Name Ultra Rectangle Double Hung (UDH)
Configured in PK Version 759

Scaled To Fit

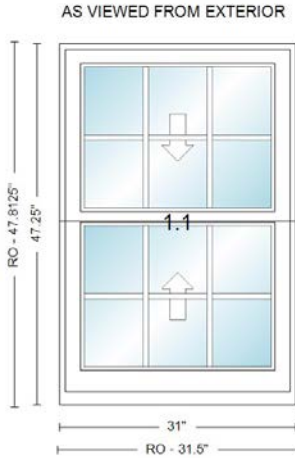

Quantity (7)
Cubic Feet 6.42
Unit Price \$2,248.92
Extended Price \$15,742.44

*** Pricing Details ***

Base Price \$902.85
Lower Glass PDL \$245.25
Upper Glass PDL \$245.25
Screen \$44.19
Non-Standard Size \$265.13
Hardware Color \$54.03
Lower Glass Glass \$5.22
Upper Glass Glass \$5.22
Screen Prep \$34.15
Interior Finish \$269.15
Lower Glass Lite Finish \$89.24
Upper Glass Lite Finish \$89.24

*** Overall Dimensions ***

Overall Frame Width 31"
Overall Frame Height 47 1/4"
Overall Rough Opening Width 31 1/2"
Overall Rough Opening Height 47 13/16"
Overall Unit Dimension Width 31"
Overall Unit Dimension Height 47 1/4"

*** Dimensions ***

Call Width Custom
Call Height Custom
Individual Frame Width 31"
Individual Frame Height 47 1/4"
Clear Opening Width 27 15/32"
Clear Opening Height 17 25/32"

Glass Width 25 1/2"
Glass Height 19 13/32"

*** Casing-Jamb-Trim ***

Exterior Casing/Accessories No Casing
Sill Nosing No Sill Nosing
Nailing Fin No
Back Priming of Frame No
Jamb Depth 4 9/16"
Installation Clips None
Kolbe Installation Consulting No

*** Performance ***

Performance Standard Performance

*** Unit ***

Unit Type Complete Unit
Unit Package No Package
Model Sterling
Production Current
Vintage #1117
Sash Material Extruded
Basic Jamb Profile Square

*** Glass ***

Glass Make Up Double Glazed
Glass Solar Low-E
Glass Spacer Mill Finish
High Altitude No
Glass Preserve / Neat+ Coating Glass Preserve without Neat+ Coating
Glazing Bead Ovolo
Upper Glass - Glass Type Clear
Upper Glass - Obscure / Opaque Glass None
Upper Glass NOT Tempered
Lower Glass - Glass Type Clear
Lower Glass - Obscure / Opaque Glass None
Lower Glass NOT Tempered

*** Lite Divisions - Upper ***

Lite Division Performance Divided Lites
Bar Profile - Exterior Beveled
Bar Profile - Interior Ovolo
Bar Size 5/8"
Internal Spacers Champagne
Second Bar Size None
Grid Pattern Colonial
Colonial Division 3W2H
Grille Division Type Specified

*** Lite Divisions - Lower ***

Lite Division Performance Divided Lites
Bar Profile - Exterior Beveled
Bar Profile - Interior Ovolo
Bar Size 5/8"
Internal Spacers Champagne



Printed By: Steve Davis

Created: 5/26/2023

This report does not include Non-Kolbe Items

2023 Pricing

Window and Door Details Page 42 of 76

For warranty information please click this link or visit <https://www.kolbewindows.com/resources/warranties>

WINDOW 13, 14, 15, 16, 17, 18, 19

Quote 1217694C: 45 W LENOX STREET

Merit Commercial Windows, Inc

6/19/2023 3:31:55 PM

Window and Door Details

Second Bar Size	None
Grid Pattern	Colonial
Colonial Divison	3W2H
Grille Division Type	Specified
Lite Bar Alignment	Align Vertical

*** Hardware-Accessories ***

Lock Style	Spoon
Hardware Color	Antique Brass
Bottom Sash Lift Handle(s)	No
Screen	Half Screen
Mesh Type	BetterVue Fiberglass
Screen(s) Applied	No
Ogee Lugs	No
Jambliner	Black
Window Opening Control Device	No
Class 5 Balance	No

*** Species-Finish-Color ***

Change Species	Leave All Pine
Exterior Frame Finish	70% Fluoropolymer
Exterior Sash Finish	70% Fluoropolymer
Match All Exterior Colors	Yes
Exterior Color	Ultra Pure White
Interior Frame Finish	Colored Prefinish
Interior Sash Finish	Colored Prefinish
Match All Interior Colors	Yes
Interior Color	Coal Black
Jambliner Cover	Wood Wrapped
Vertical Weatherstrip Color	Black
Fingerjoints	Standard Fingerjoints



Printed By: Steve Davis

Created: 5/26/2023

This report does not include Non-Kolbe Items

2023 Pricing

Window and Door Details Page 43 of 76

For warranty information please click this link or visit <https://www.kolbewindows.com/resources/warranties>

WINDOW 13, 14, 15, 16, 17, 18, 19

Quote 1217694C: 45 W LENOX STREET

Merit Commercial Windows, Inc

6/19/2023 3:31:55 PM

010 FRONT, SIDE, REAR-OFFICE EA (7) 6.42 \$2,248.92 \$15,742.44

*** Unit ***

UDH (Assy 1)

Ultra Rectangle Double Hung

*** Unit ***

Unit 1.1: #1117 Vintage, Extruded Sash, Sterling, Square Basic Jamb Profile

*** Glass ***

Unit 1.1: Solar Low-E Glass

*** Lite Divisions ***

Unit 1.1 Lower: Performance Divided Lites, Colonial, Align Vertical Bars, 3W2H, 5/8" Bars, Beveled Bars - Exterior

Unit 1.1 Upper: Performance Divided Lites, Colonial, 3W2H, 5/8" Bars, Beveled Bars - Exterior

*** Hardware-Accessories ***

Unit 1.1: Antique Brass Hardware, Spoon Lock, BetterVue Fiberglass Half Screen, Screen(s) Loose

*** Species-Finish-Color ***

Unit 1.1: 70% Fluoropolymer Exterior Sash, 70% Fluoropolymer Exterior Frame, Ultra Pure White Exterior, Colored Prefinish Interior Sash, Colored Prefinish Interior Frame, Coal Black Interior, Wood Wrapped Jambliner, Black Vertical Weatherstrip

*** Casing-Jambs-Trim ***

Unit 1.1: No Casing, No Sill Nosing, No Nailing Fin, 4-9/16" Jambs

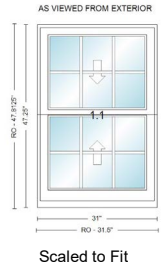

Rough Opening:
31 1/2" X 47 13/16"

Frame Size:
31" X 47 1/4"

Unit Dimension:
31" X 47 1/4"



Printed By: Steve Davis

Created: 5/26/2023

* Indicates Increased Rough Opening

2023 Pricing

Summary Page 10 of 76

For warranty information please click this link or visit <https://www.kolbewindows.com/resources/warranties>

WINDOW 20

THIS DRAWING AND THE INFORMATION IT CONTAINS ARE THE PROPERTY OF KOLBE & KOLBE MILLWORK CO., INC. AND ARE PROPRIETARY AND CONFIDENTIAL TO KOLBE & KOLBE MILLWORK CO., INC. ANY UNAUTHORIZED PUBLICATION, COPYING, USE, REPRODUCTION, DISCLOSURE OR DISSEMINATION OF THE DRAWING OR INFORMATION BY ANY MEANS (INCLUDING ELECTRONIC MEANS) IS PROHIBITED.

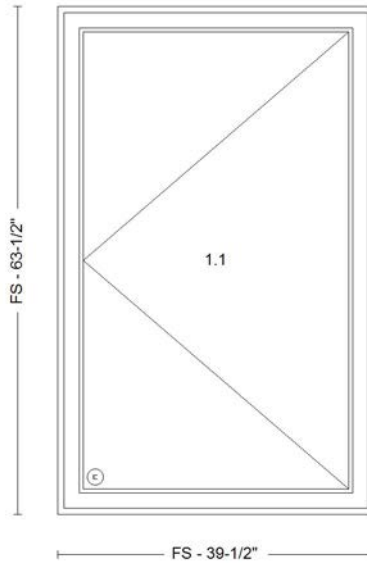

FS: 39-1/2" X 63-1/2"

RO: 40" X 64"

UD: 39-1/2" X 63-1/2"

Ultra Rectangle Casement
UCS (Assy 1)

NOT FOR PRODUCTION USE

CUSTOMER: MERIT COMMERCIAL WINDOWS, INC	LINE: 022-1	QUANTITY: 1
PRINTED BY: STEVE DAVIS	LABEL: REAR-SUNROOM-CRANK OUT ONLY!!!	
PROJECT: 45 W LENOX STREET		
QUOTE 1217694: 45 W LENOX STREET	PK VERSION: 759	
PRINTED: 6/19/2023 3:34 PM		

Window and Door Details

Line Number 022-1
Label REAR-SUNROOM-CRANK OUT ONLY!!!
Product Name Ultra Rectangle Casement (UCS)
Configured in PK Version 759

Scaled To Fit

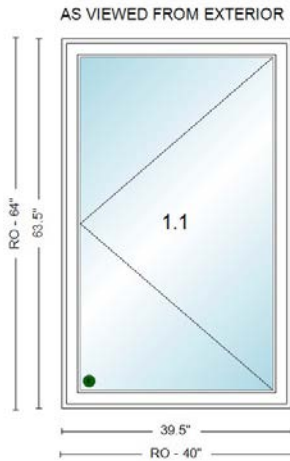

Quantity (1)
Cubic Feet 13.34
Unit Price \$2,697.37
Extended Price \$2,697.37

*** Pricing Details ***

Base Price \$1,357.80
Screen \$437.37
Non-Standard Size \$198.85
Glass \$20.64
Interior Finish \$406.74
Screen Finish \$188.61
Screen Loose/Applied \$87.37

*** Notes ***

Manufacturer Note: Opening(s) designated by a circled 'E' meet most national building codes for emergency escape and rescue requirements. Check local codes for product compliance for desired application.

*** Overall Dimensions ***

Overall Frame Width 39 1/2"
Overall Frame Height 63 1/2"
Overall Rough Opening Width 40"
Overall Rough Opening Height 64"
Overall Unit Dimension Width 39 1/2"
Overall Unit Dimension Height 63 1/2"

*** Dimensions ***

Individual Frame Width 39 1/2"
Individual Frame Height 63 1/2"
Clear Opening Width 27 5/32"
Clear Opening Height 55 13/16"
Glass Width 34 1/8"
Glass Height 58 1/8"

*** Casing-Jambs-Trim ***

Exterior Casing/Accessories No Casing
Sill Nosing No Sill Nosing
Nailing Fin No
Back Priming of Frame No
Jamb Depth 5 1/16"
Jambs Exact No
Offset Jambs No Offset
Jambs Applied Yes
Modern Trim Extension Jamb No
Installation Clips None
Kolbe Installation Consulting No

*** Performance ***

Performance Standard Performance

*** Unit ***

Unit Type Complete Unit
Unit Package No Package
Model XL Crank Out
Production Current
Hinging Left
Sash Material Extruded
Stop Profile Stepped

*** Glass ***

Glass Make Up Double Glazed
Glass Solar Low-E
Glass Spacer Mill Finish
High Altitude No
Glass Preserve / Neat+ Coating Glass Preserve without Neat+ Coating
Glazing Bead Ovolo
Glass Type Clear
Obscure / Opaque Glass None
 NOT Tempered

*** Hardware-Accessories ***

Window Hardware Standard
Lock Lever Style Traditional
Hardware Color Clay (Rustic)
Custodial Lock No
Crank Cover and Handle Yes
Operating Hardware Stainless Steel
Locking Hardware Stainless Steel
Screen Retractable Screen
Retractable Screen Side Cover Beveled
Mesh Type BetterVue Fiberglass
Screen(s) Applied Yes
Window Opening Control Device No

*** Species-Finish-Color ***

Change Species Leave All Pine
Exterior Frame Finish 70% Fluoropolymer
Exterior Sash Finish 70% Fluoropolymer
Match All Exterior Colors Yes



Printed By: Steve Davis

Created: 5/26/2023

This report does not include Non-Kolbe Items

2023 Pricing

Window and Door Details Page 66 of 76

For warranty information please click this link or visit <https://www.kolbewindows.com/resources/warranties>

Window and Door Details

Exterior Color	Ultra Pure White
Interior Frame Finish	Colored Prefinish
Interior Sash Finish	Colored Prefinish
Match All Interior Colors	Yes
Interior Color	Ultra Pure White
Screen Color	White Channel with Black Weatherstrip
Screen Finish	Colored Prefinish
Screen Finish Color	Ultra Pure White
Fingerjoints	Standard Fingerjoints



022 REAR-SUNROOM-CRANK OUT ONLY!!! EA (1) 13.34 \$2,697.37 \$2,697.37

*** Unit ***

UCS (Assy 1)

Ultra Rectangle Casement

*** Unit ***

Unit 1.1: Extruded Sash, XL Crank Out, Left Hinging

*** Glass ***

Unit 1.1: Solar Low-E Glass

*** Hardware-Accessories ***

Unit 1.1: Standard Window Hardware, Traditional Lock Lever, Clay (Rustic) Hardware, Stainless Steel Locking Hardware, Stainless Steel Operating Hardware, BetterVue Fiberglass Retractable Screen

*** Species-Finish-Color ***

Unit 1.1: 70% Fluoropolymer Exterior Sash, 70% Fluoropolymer Exterior Frame, Ultra Pure White Exterior, Colored Prefinish Interior Sash, Colored Prefinish Interior Frame, Ultra Pure White Interior, White Screen Channel with Black Weatherstrip, Ultra Pure White Colored Prefinish Screen

*** Casing-Jambs-Trim ***

Unit 1.1: No Casing, No Sill Nosing, No Nailing Fin, 5-1/16" Jambs

Opening(s) designated by a circled 'E' meet most national building codes for emergency escape and rescue requirements. Check local codes for product compliance for desired application.

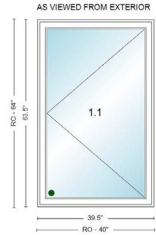

Scaled to Fit

**Rough Opening:
40" X 64"**

**Frame Size:
39 1/2" X 63 1/2"**

**Unit Dimension:
39 1/2" X 63 1/2"**



WINDOW 21

THIS DRAWING AND THE INFORMATION IT CONTAINS ARE THE PROPERTY OF KOLBE & KOLBE MILLWORK CO., INC. AND ARE PROPRIETARY AND CONFIDENTIAL TO KOLBE & KOLBE MILLWORK CO., INC. ANY UNAUTHORIZED PUBLICATION, COPYING, USE, REPRODUCTION, DISCLOSURE OR DISSEMINATION OF THE DRAWING OR INFORMATION BY ANY MEANS (INCLUDING ELECTRONIC MEANS) IS PROHIBITED.

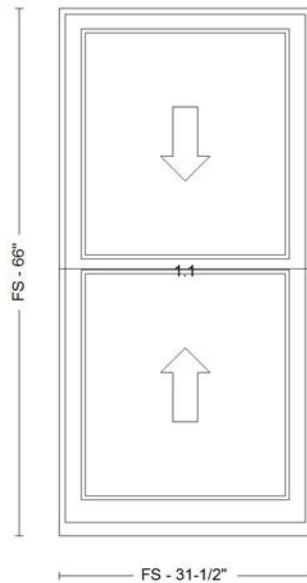

FS: 31-1/2" X 66"
 RO: 32" X 66-9/16"
 UD: 31-1/2" X 66"

Ultra Rectangle Double Hung
 UDH (Assy 1)

NOT FOR PRODUCTION USE

CUSTOMER: MERIT COMMERCIAL WINDOWS, INC	LINE: 024-1	QUANTITY: 3
PRINTED BY: STEVE DAVIS	LABEL: KITCHEN REPLACEMENTS	
PROJECT: 45 W LENOX STREET		
QUOTE 1217694: 45 W LENOX STREET	PK VERSION: 759	
PRINTED: 6/19/2023 3:34 PM		

WINDOW 21

Quote 1217694C: 45 W LENOX STREET

Merit Commercial Windows, Inc

6/19/2023 3:31:55 PM

Window and Door Details

Line Number 023-1
Label REAR-SUNROOM-CRANK OUT ONLY!!!
Product Name Ultra Rectangle Casement (UCS)
Configured in PK Version 759

Scaled To Fit

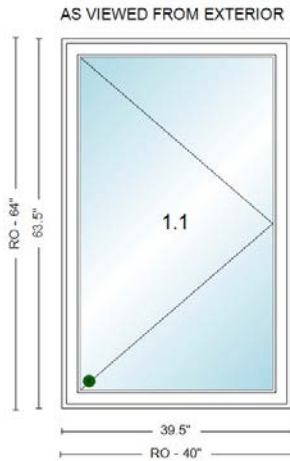

Quantity (1)
Cubic Feet 13.34
Unit Price \$2,697.37
Extended Price \$2,697.37

*** Pricing Details ***

Base Price \$1,357.80
Screen \$437.37
Non-Standard Size \$198.85
Glass \$20.64
Interior Finish \$406.74
Screen Finish \$188.61
Screen Loose/Applied \$87.37

*** Notes ***

Manufacturer Note: Opening(s) designated by a circled 'E' meet most national building codes for emergency escape and rescue requirements. Check local codes for product compliance for desired application.

*** Overall Dimensions ***

Overall Frame Width 39 1/2"
Overall Frame Height 63 1/2"
Overall Rough Opening Width 40"
Overall Rough Opening Height 64"
Overall Unit Dimension Width 39 1/2"
Overall Unit Dimension Height 63 1/2"

*** Dimensions ***

Individual Frame Width 39 1/2"
Individual Frame Height 63 1/2"
Clear Opening Width 27 5/32"
Clear Opening Height 55 13/16"
Glass Width 34 1/8"
Glass Height 58 1/8"

*** Casing-Jamb-Trim ***

Exterior Casing/Accessories No Casing
Sill Nosing No Sill Nosing
Nailing Fin No
Back Priming of Frame No
Jamb Depth 5 1/16"
Jamb Exact No
Offset Jamb No Offset
Jamb Applied Yes
Modern Trim Extension Jamb No
Installation Clips None
Kolbe Installation Consulting No

*** Performance ***

Performance Standard Performance
Job Specification PG Rating Entry Do Not Specify

*** Unit ***

Unit Type Complete Unit
Unit Package No Package
Model XL Crank Out
Production Current
Hinging Right
Sash Material Extruded
Stop Profile Stepped

*** Glass ***

Glass Make Up Double Glazed
Glass Solar Low-E
Glass Spacer Mill Finish
High Altitude No
Glass Preserve / Neat+ Coating Glass Preserve without Neat+ Coating
Glazing Bead Ovolo
Glass Type Clear
Obscure / Opaque Glass None
 NOT Tempered

*** Hardware-Accessories ***

Window Hardware Standard
Lock Lever Style Traditional
Hardware Color Clay (Rustic)
Custodial Lock No
Crank Cover and Handle Yes
Operating Hardware Stainless Steel
Locking Hardware Stainless Steel
Screen Retractable Screen
Retractable Screen Side Cover Beveled
Mesh Type BetterVue Fiberglass
Screen(s) Applied Yes
Window Opening Control Device No

*** Species-Finish-Color ***

Change Species Leave All Pine
Exterior Frame Finish 70% Fluoropolymer
Exterior Sash Finish 70% Fluoropolymer



Printed By: Steve Davis

Created: 5/26/2023

This report does not include Non-Kolbe Items

2023 Pricing

Window and Door Details Page 68 of 76

For warranty information please click this link or visit <https://www.kolbewindows.com/resources/warranties>

Window and Door Details

Match All Exterior Colors	Yes
Exterior Color	Ultra Pure White
Interior Frame Finish	Colored Prefinish
Interior Sash Finish	Colored Prefinish
Match All Interior Colors	Yes
Interior Color	Ultra Pure White
Screen Color	White Channel with Black Weatherstrip
Screen Finish	Colored Prefinish
Screen Finish Color	Ultra Pure White
Fingerjoints	Standard Fingerjoints



WINDOW 21

023 REAR-SUNROOM-CRANK OUT ONLY!!! EA (1) 13.34 \$2,697.37 \$2,697.37

***** Unit *****

UCS (Assy 1)

Ultra Rectangle Casement

***** Unit *****

Unit 1.1: Extruded Sash, XL Crank Out, Right Hinging

***** Glass *****

Unit 1.1: Solar Low-E Glass

***** Hardware-Accessories *****

Unit 1.1: Standard Window Hardware, Traditional Lock Lever, Clay (Rustic) Hardware, Stainless Steel Locking Hardware, Stainless Steel Operating Hardware, BetterVue Fiberglass Retractable Screen

***** Species-Finish-Color *****

Unit 1.1: 70% Fluoropolymer Exterior Sash, 70% Fluoropolymer Exterior Frame, Ultra Pure White Exterior, Colored Prefinish Interior Sash, Colored Prefinish Interior Frame, Ultra Pure White Interior, White Screen Channel with Black Weatherstrip, Ultra Pure White Colored Prefinish Screen

***** Casing-Jambs-Trim *****

Unit 1.1: No Casing, No Sill Nosing, No Nailing Fin, 5-1/16" Jambs

Opening(s) designated by a circled 'E' meet most national building codes for emergency escape and rescue requirements. Check local codes for product compliance for desired application.

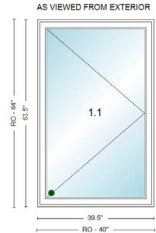

Scaled to Fit

**Rough Opening:
40" X 64"**

**Frame Size:
39 1/2" X 63 1/2"**

**Unit Dimension:
39 1/2" X 63 1/2"**

024 KITCHEN REPLACEMENTS EA (3) 10.21 \$1,716.13 ~~\$5,148.39~~

***** Unit *****

UDH (Assy 1)

Ultra Rectangle Double Hung

***** Unit *****

Unit 1.1: #1117 Vintage, Extruded Sash, Sterling, Square Basic Jamb Profile

***** Glass *****

Unit 1.1: Solar Low-E Glass

***** Hardware-Accessories *****

Unit 1.1: Antique Brass Hardware, Spoon Lock, BetterVue Fiberglass Half Screen, Screen(s) Loose

***** Species-Finish-Color *****

Unit 1.1: 70% Fluoropolymer Exterior Sash, 70% Fluoropolymer Exterior Frame, Ultra Pure White Exterior, Colored Prefinish Interior Sash, Colored Prefinish Interior Frame, Ultra Pure White Interior, Wood Wrapped Jambliner, Black Vertical Weatherstrip

***** Casing-Jambs-Trim *****

Unit 1.1: No Casing, No Sill Nosing, No Nailing Fin, 4-9/16" Jambs

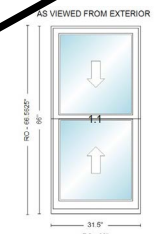

Scaled to Fit

**Rough Opening:
32" X 66 9/16"**

**Frame Size:
31 1/2" X 66"**

**Unit Dimension:
31 1/2" X 66"**



DOOR- LABLED 22

THIS DRAWING AND THE INFORMATION IT CONTAINS ARE THE PROPERTY OF KOLBE & KOLBE MILLWORK CO., INC. AND ARE PROPRIETARY AND CONFIDENTIAL TO KOLBE & KOLBE MILLWORK CO., INC. ANY UNAUTHORIZED PUBLICATION, COPYING, USE, REPRODUCTION, DISCLOSURE OR DISSEMINATION OF THE DRAWING OR INFORMATION BY ANY MEANS (INCLUDING ELECTRONIC MEANS) IS PROHIBITED.

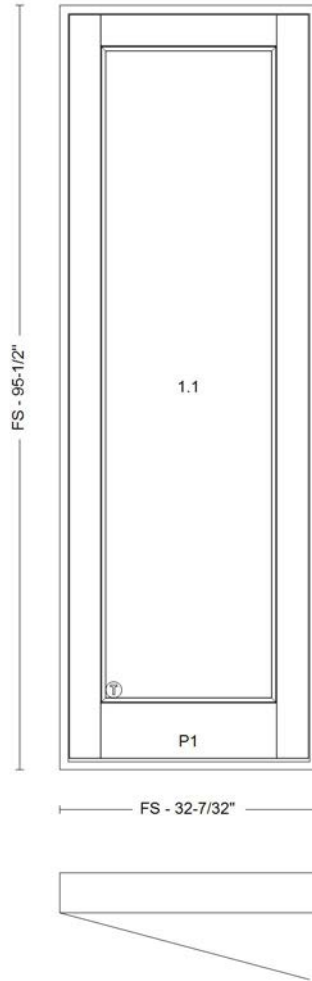

FS: 32-7/32" X 95-1/2"
 RO: 32-23/32" X 96"
 UD: 32-7/32" X 95-1/2"

Ultra Rectangle Exterior Swinging Door
 UXD (Assy 1)

NOT FOR PRODUCTION USE

CUSTOMER: MERIT COMMERCIAL WINDOWS, INC	LINE: 025-1	QUANTITY: 1
PRINTED BY: STEVE DAVIS	LABEL: KITCHEN REAR	
PROJECT: 45 W LENOX STREET		
QUOTE 1217694: 45 W LENOX STREET	PK VERSION: 759	
PRINTED: 6/19/2023 3:34 PM		

DOOR- LABELED 22

Quote 1217694C: 45 W LENOX STREET

Merit Commercial Windows, Inc

6/19/2023 3:31:55 PM

Window and Door Details

Line Number **025-1**
 Label **KITCHEN REAR**
 Product Name **Ultra Rectangle Exterior Swinging Door (UXD)**
 Configured in PK Version **759**

Scaled To Fit

AS VIEWED FROM EXTERIOR



Quantity **(1)**
 Cubic Feet **13**
 Unit Price **\$4,933.17**
 Extended Price **\$4,933.17**

*** Pricing Details ***

Frame **\$1,350.77**
 Panel **\$1,512.46**
 Outswing **\$197.85**
 Glass **\$18.03**
 Hardware **\$530.16**
 Hinges **\$257.10**
 Non-Standard Size Panel **\$251.07**
 Non-Standard Size Frame **\$66.28**
 Interior Finish **\$486.08**
 Strike Color **\$151.90**
 Multi-Pt Special Height **\$111.48**

*** Overall Dimensions ***

Overall Frame Width **32 7/32"**
 Overall Frame Height **95 1/2"**
 Overall Rough Opening Width **32 23/32"**
 Overall Rough Opening Height **96"**
 Overall Unit Dimension Width **32 7/32"**
 Overall Unit Dimension Height **95 1/2"**

*** Dimensions ***

Call Width **2-6**
 Call Height **Custom**
 Individual Frame Width **32 7/32"**
 Individual Frame Height **95 1/2"**
 Clear Opening Width **27 3/32"**
 Clear Opening Height **91 29/32"**
 Slab Width **29 13/16"**

Slab Height **92 29/32"**
 Glass Width **21 11/16"**
 Glass Height **81 13/16"**

*** Casing-Jamb-Trim ***

Door Sill **Aluminum**
 Door Sill Color **Dark Bronze Anodized**
 Exterior Casing/Accessories **No Casing**
 Extended Horns **No**
 Nailing Fin **No**
 Back Priming of Frame **No**
 Jamb Depth **4 9/16"**
 Modern Trim Extension Jamb **No**
 Installation Clips **None**
 Kolbe Installation Consulting **No**

*** Performance ***

Performance **Standard Performance**

*** Unit ***

Unit Type **Complete Unit**
 Model **Ultra**
 Production **Current**
 Operation **Outswing**
 Hinging (As Door Pulls Towards You) **Left**
 Sash Material **Extruded**
 Panel Style **Full Lite**
 Panel Thickness **1 3/4"**
 Frame Thickness **1 3/4"**

*** Glass ***

Glass Make Up **Double Glazed**
 Glass **Solar Low-E**
 Glass Spacer **Mill Finish**
 High Altitude **No**
 Glass Preserve / Neat+ Coating **Glass Preserve without Neat+ Coating**
 Glazing Bead **Ovolo**
 Glass Type **Clear**
 Obscure / Opaque Glass **None**
 Tempered

*** Hardware-Accessories ***

Door Hardware **Multi-Point Lock**
 Multi-Point Type **European Style-Deadbolt on Bottom**
 Door Handle Type **Toronto**
 Hardware Color **Antique Brass**
 Keyed Alike **Keyed As Pulled From Shelf**
 Door Strike Color **Antique Brass**
 Lock Height **Standard Lock Height**
 Backset **45 mm**
 Hinge Type **Adjustable Hinges**
 Hinge Color **Antique Brass**
 Screen **No Screen - No Prep**
 Include Construction Door Panel **No**



Printed By: Steve Davis

Created: 5/26/2023

This report does not include Non-Kolbe Items

2023 Pricing

Window and Door Details Page 72 of 76

For warranty information please click this link or visit <https://www.kolbewindows.com/resources/warranties>

DOOR- LABELED 22

Quote 1217694C: 45 W LENOX STREET

Merit Commercial Windows, Inc

6/19/2023 3:31:55 PM

Window and Door Details

*** Species-Finish-Color ***

Change Species	Leave All Pine
Exterior Frame Finish	70% Fluoropolymer
Exterior Sash Finish	70% Fluoropolymer
Match All Exterior Colors	Yes
Exterior Color	Ultra Pure White
Interior Frame Finish	Colored Prefinish
Interior Sash Finish	Colored Prefinish
Match All Interior Colors	Yes
Interior Color	Ultra Pure White
Weatherstrip Color	Black
Fingerjoints	Standard Fingerjoints



Printed By: Steve Davis

Created: 5/26/2023

This report does not include Non-Kolbe Items

2023 Pricing

Window and Door Details Page 73 of 76

For warranty information please click this link or visit <https://www.kolbewindows.com/resources/warranties>

DOOR- LABELED 22

025 KITCHEN REAR EA (1) 13.00 \$4,933.17 \$4,933.17

***** Unit *****

UXD (Assy 1)

Ultra Rectangle Exterior Swinging Door

***** Unit *****

Unit 1.1: Extruded Sash, Ultra, Outswing, Left Hinging, Full Lite Panel Style

***** Glass *****

Unit 1.1: Solar Low-E Glass

Unit 1.1: Tempered Glass

***** Hardware-Accessories *****

Unit 1.1: Multi-Point Lock Door Hardware, European Style-Deadbolt on Bottom, Antique Brass Hardware, 45 mm Backset, Standard Lock Height, Antique Brass Hinges

***** Species-Finish-Color *****

Unit 1.1: 70% Fluoropolymer Exterior Sash, 70% Fluoropolymer Exterior Frame, Ultra Pure White Exterior, Colored Prefinish Interior Sash, Colored Prefinish Interior Frame, Ultra Pure White Interior

***** Casing-Jambs-Trim *****

Unit 1.1: No Casing, No Nailing Fin, 4-9/16" Jambs

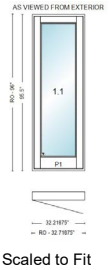

**Rough Opening:
32 23/32" X 96"**

**Frame Size:
32 7/32" X 95 1/2"**

**Unit Dimension:
32 7/32" X 95 1/2"**

~~**026 KITCHEN FRONT EA (1) 11.58 \$4,023.58 \$4,023.58**~~

~~***** Unit *****~~

~~UXD (Assy 1)~~

~~Ultra Rectangle Exterior Swinging Door~~

~~***** Unit *****~~

~~Unit 1.1: Extruded Sash, Ultra, Inswing, Right Hinging, Full Lite Panel Style~~

~~***** Glass *****~~

~~Unit 1.1: Solar Low-E Glass~~

~~Unit 1.1: Tempered Glass~~

~~***** Hardware-Accessories *****~~

~~Unit 1.1: Multi-Point Lock Door Hardware, European Style-Deadbolt on Bottom, Antique Brass Hardware, 45 mm Backset, Standard Lock Height, Antique Brass Hinges~~

~~***** Species-Finish-Color *****~~

~~Unit 1.1: 70% Fluoropolymer Exterior Sash, 70% Fluoropolymer Exterior Frame, Ultra Pure White Exterior, Colored Prefinish Interior Sash, Colored Prefinish Interior Frame, Ultra Pure White Interior~~

~~***** Casing-Jambs-Trim *****~~

~~Unit 1.1: No Casing, No Nailing Fin, 4-9/16" Jambs~~

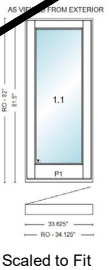

~~**Rough Opening:
34 1/8" X 82"**~~

~~**Frame Size:
33 5/8" X 81 1/2"**~~

~~**Unit Dimension:
33 5/8" X 81 1/2"**~~



WINDOW 23, 24, 25

THIS DRAWING AND THE INFORMATION IT CONTAINS ARE THE PROPERTY OF KOLBE & KOLBE MILLWORK CO., INC. AND ARE PROPRIETARY AND CONFIDENTIAL TO KOLBE & KOLBE MILLWORK CO., INC. ANY UNAUTHORIZED PUBLICATION, COPYING, USE, REPRODUCTION, DISCLOSURE OR DISSEMINATION OF THE DRAWING OR INFORMATION BY ANY MEANS (INCLUDING ELECTRONIC MEANS) IS PROHIBITED.

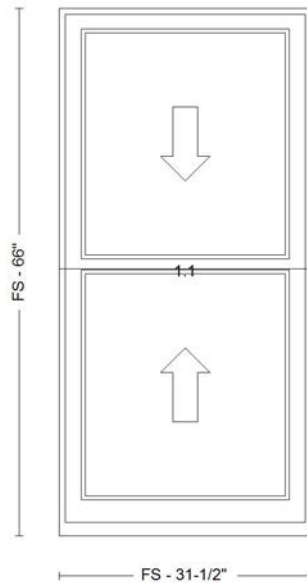

FS: 31-1/2" X 66"
 RO: 32" X 66-9/16"
 UD: 31-1/2" X 66"

Ultra Rectangle Double Hung
 UDH (Assy 1)

NOT FOR PRODUCTION USE

CUSTOMER: MERIT COMMERCIAL WINDOWS, INC	LINE: 024-1	QUANTITY: 3
PRINTED BY: STEVE DAVIS	LABEL: KITCHEN REPLACEMENTS	
PROJECT: 45 W LENOX STREET		
QUOTE 1217694: 45 W LENOX STREET	PK VERSION: 759	
PRINTED: 6/19/2023 3:34 PM		

WINDOW 23, 24, 25

Quote 1217694C: 45 W LENOX STREET

Merit Commercial Windows, Inc

6/19/2023 3:31:55 PM

Window and Door Details

Line Number 024-1
Label KITCHEN REPLACEMENTS
Product Name Ultra Rectangle Double Hung (UDH)
Configured in PK Version 759

Scaled To Fit

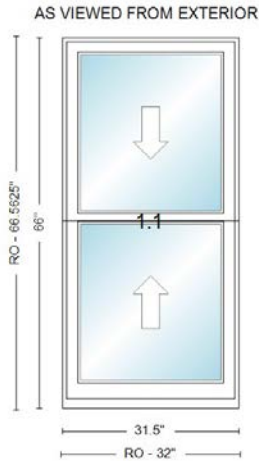

Quantity (3)
Cubic Feet 10.21
Unit Price \$1,716.13
Extended Price \$5,148.39

*** Pricing Details ***

Base Price \$1,106.73
Screen \$52.22
Non-Standard Size \$140.60
Hardware Color \$54.03
Lower Glass Glass \$7.53
Upper Glass Glass \$7.53
Screen Prep \$34.15
Interior Finish \$313.34

*** Overall Dimensions ***

Overall Frame Width 31 1/2"
Overall Frame Height 66"
Overall Rough Opening Width 32"
Overall Rough Opening Height 66 9/16"
Overall Unit Dimension Width 31 1/2"
Overall Unit Dimension Height 66"

*** Dimensions ***

Call Width 26
Call Height Custom
Individual Frame Width 31 1/2"
Individual Frame Height 66"
Clear Opening Width 27 31/32"
Clear Opening Height 27 5/32"
Glass Width 26"
Glass Height 28 25/32"

*** Casing-Jamb-Trim ***

Exterior Casing/Accessories No Casing

Sill Nosing No Sill Nosing
Nailing Fin No
Back Priming of Frame No
Jamb Depth 4 9/16"
Installation Clips None
Kolbe Installation Consulting No

*** Performance ***

Performance Standard Performance

*** Unit ***

Unit Type Complete Unit
Unit Package No Package
Model Sterling
Production Current
Vintage #1117
Sash Material Extruded
Basic Jamb Profile Square

*** Glass ***

Glass Make Up Double Glazed
Glass Solar Low-E
Glass Spacer Mill Finish
High Altitude No
Glass Preserve / Neat+ Coating Glass Preserve without Neat+ Coating

Glazing Bead Ovolo
Upper Glass - Glass Type Clear
Upper Glass - Obscure / Opaque Glass None
Upper Glass NOT Tempered
Lower Glass - Glass Type Clear
Lower Glass - Obscure / Opaque Glass None
Lower Glass NOT Tempered

*** Hardware-Accessories ***

Lock Style Spoon
Hardware Color Antique Brass
Bottom Sash Lift Handle(s) No
Screen Half Screen
Mesh Type BetterVue Fiberglass
Screen(s) Applied No
Ogee Lugs No
Jambliner Black
Window Opening Control Device No
Class 5 Balance No

*** Species-Finish-Color ***

Change Species Leave All Pine
Exterior Frame Finish 70% Fluoropolymer
Exterior Sash Finish 70% Fluoropolymer
Match All Exterior Colors Yes
Exterior Color Ultra Pure White
Interior Frame Finish Colored Prefinish
Interior Sash Finish Colored Prefinish
Match All Interior Colors Yes



Printed By: Steve Davis

Created: 5/26/2023

This report does not include Non-Kolbe Items

2023 Pricing

Window and Door Details Page 70 of 76

For warranty information please click this link or visit <https://www.kolbewindows.com/resources/warranties>

WINDOW 23, 24, 25

Quote 1217694C: 45 W LENOX STREET

Merit Commercial Windows, Inc

6/19/2023 3:31:55 PM

Window and Door Details

Interior Color	Ultra Pure White
Jambliner Cover	Wood Wrapped
Vertical Weatherstrip Color	Black
Fingerjoints	Standard Fingerjoints



Printed By: Steve Davis

Created: 5/26/2023

This report does not include Non-Kolbe Items

2023 Pricing

Window and Door Details Page 71 of 76

For warranty information please click this link or visit <https://www.kolbewindows.com/resources/warranties>

023 REAR-SUNROOM-CRANK OUT ONLY!!! EA (1) 13.34 \$2,697.37 \$2,697.37

*** Unit ***
UCS (Assy 1)

Ultra Rectangle Casement

*** Unit ***
Unit 1.1: Extruded Sash, XL Crank Out, Right Hinging

*** Glass ***
Unit 1.1: Solar Low-E Glass

*** Hardware-Accessories ***
Unit 1.1: Standard Window Hardware, Traditional Lock Lever, Clay (Rustic) Hardware, Stainless Steel Locking Hardware, Stainless Steel Operating Hardware, BetterVue Fiberglass Retractable Screen

*** Species-Finish-Color ***
Unit 1.1: 70% Fluoropolymer Exterior Sash, 70% Fluoropolymer Exterior Frame, Ultra Pure White Exterior, Colored Prefinish Interior Sash, Colored Prefinish Interior Frame, Ultra Pure White Interior, White Screen Channel with Black Weatherstrip, Ultra Pure White Colored Prefinish Screen

*** Casing-Jambs-Trim ***
Unit 1.1: No Casing, No Sill Nosing, No Nailing Fin, 5-1/16" Jambs

Opening(s) designated by a circled 'E' meet most national building codes for emergency escape and rescue requirements. Check local codes for product compliance for desired application.

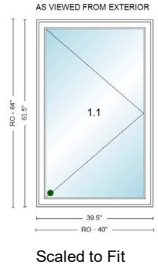

**Rough Opening:
40" X 64"**

**Frame Size:
39 1/2" X 63 1/2"**

**Unit Dimension:
39 1/2" X 63 1/2"**

024 KITCHEN REPLACEMENTS EA (3) 10.21 \$1,716.13 \$5,148.39

*** Unit ***
UDH (Assy 1)

WINDOW 23, 24, 25

Ultra Rectangle Double Hung

*** Unit ***
Unit 1.1: #1117 Vintage, Extruded Sash, Sterling, Square Basic Jamb Profile

*** Glass ***
Unit 1.1: Solar Low-E Glass

*** Hardware-Accessories ***
Unit 1.1: Antique Brass Hardware, Spoon Lock, BetterVue Fiberglass Half Screen, Screen(s) Loose

*** Species-Finish-Color ***
Unit 1.1: 70% Fluoropolymer Exterior Sash, 70% Fluoropolymer Exterior Frame, Ultra Pure White Exterior, Colored Prefinish Interior Sash, Colored Prefinish Interior Frame, Ultra Pure White Interior, Wood Wrapped Jambliner, Black Vertical Weatherstrip

*** Casing-Jambs-Trim ***
Unit 1.1: No Casing, No Sill Nosing, No Nailing Fin, 4-9/16" Jambs

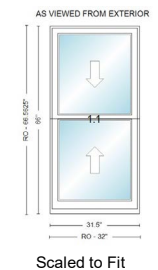

**Rough Opening:
32" X 66 9/16"**

**Frame Size:
31 1/2" X 66"**

**Unit Dimension:
31 1/2" X 66"**



WINDOW 26, 27

THIS DRAWING AND THE INFORMATION IT CONTAINS ARE THE PROPERTY OF KOLBE & KOLBE MILLWORK CO., INC. AND ARE PROPRIETARY AND CONFIDENTIAL TO KOLBE & KOLBE MILLWORK CO., INC. ANY UNAUTHORIZED PUBLICATION, COPYING, USE, REPRODUCTION, DISCLOSURE OR DISSEMINATION OF THE DRAWING OR INFORMATION BY ANY MEANS (INCLUDING ELECTRONIC MEANS) IS PROHIBITED.

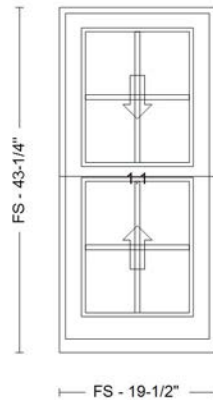

FS: 19-1/2" X 43-1/4"
 RO: 20" X 43-13/16"
 UD: 19-1/2" X 43-1/4"

Ultra Rectangle Double Hung
 UDH (Assy 1)

NOT FOR PRODUCTION USE

CUSTOMER: MERIT COMMERCIAL WINDOWS, INC	LINE: 020-1	QUANTITY: 2
PRINTED BY: STEVE DAVIS	LABEL: 3RD FL RIGHT BED	
PROJECT: 45 W LENOX STREET		
QUOTE 1217694: 45 W LENOX STREET	PK VERSION: 759	
PRINTED: 6/19/2023 3:34 PM		

WINDOW 26, 27

Quote 1217694C: 45 W LENOX STREET

Merit Commercial Windows, Inc

6/19/2023 3:31:55 PM

Window and Door Details

Line Number **020-1**
 Label **3RD FL RIGHT BED**
 Product Name **Ultra Rectangle Double Hung (UDH)**
 Configured in PK Version **759**

Scaled To Fit

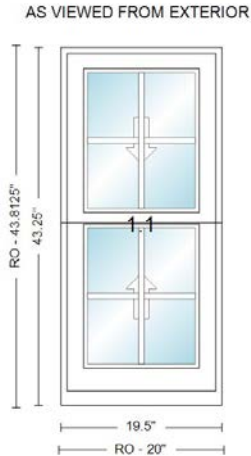

Quantity **(2)**
 Cubic Feet **3.7**
 Unit Price **\$1,834.84**
 Extended Price **\$3,669.68**

*** Pricing Details ***

Base Price **\$793.39**
 Lower Glass PDL **\$163.50**
 Upper Glass PDL **\$163.50**
 Screen **\$34.15**
 Non-Standard Size **\$265.13**
 Hardware Color **\$54.03**
 Lower Glass Glass **\$4.32**
 Upper Glass Glass **\$4.32**
 Screen Prep **\$34.15**
 Interior Finish **\$201.86**
 Lower Glass Lite Finish **\$58.25**
 Upper Glass Lite Finish **\$58.25**

*** Overall Dimensions ***

Overall Frame Width **19 1/2"**
 Overall Frame Height **43 1/4"**
 Overall Rough Opening Width **20"**
 Overall Rough Opening Height **43 13/16"**
 Overall Unit Dimension Width **19 1/2"**
 Overall Unit Dimension Height **43 1/4"**

*** Dimensions ***

Call Width **Custom**
 Call Height **Custom**
 Individual Frame Width **19 1/2"**
 Individual Frame Height **43 1/4"**
 Clear Opening Width **15 31/32"**
 Clear Opening Height **15 25/32"**

Glass Width **14"**
 Glass Height **17 13/32"**

*** Casing-Jamb-Trim ***

Exterior Casing/Accessories **No Casing**
 Sill Nosing **No Sill Nosing**
 Nailing Fin **No**
 Back Priming of Frame **No**
 Jamb Depth **4 9/16"**
 Installation Clips **None**
 Kolbe Installation Consulting **No**

*** Performance ***

Performance **Standard Performance**

*** Unit ***

Unit Type **Complete Unit**
 Unit Package **No Package**
 Model **Sterling**
 Production **Current**
 Vintage **#1117**
 Sash Material **Extruded**
 Basic Jamb Profile **Square**

*** Glass ***

Glass Make Up **Double Glazed**
 Glass **Solar Low-E**
 Glass Spacer **Mill Finish**
 High Altitude **No**
 Glass Preserve / Neat+ Coating **Glass Preserve without Neat+ Coating**
 Glazing Bead **Ovolo**
 Upper Glass - Glass Type **Clear**
 Upper Glass - Obscure / Opaque Glass **None**
 Upper Glass **NOT Tempered**
 Lower Glass - Glass Type **Clear**
 Lower Glass - Obscure / Opaque Glass **None**
 Lower Glass **NOT Tempered**

*** Lite Divisions - Upper ***

Lite Division **Performance Divided Lites**
 Bar Profile - Exterior **Beveled**
 Bar Profile - Interior **Ovolo**
 Bar Size **5/8"**
 Internal Spacers **Champagne**
 Second Bar Size **None**
 Grid Pattern **Colonial**
 Colonial Division **2W2H**
 Grille Division Type **Specified**

*** Lite Divisions - Lower ***

Lite Division **Performance Divided Lites**
 Bar Profile - Exterior **Beveled**
 Bar Profile - Interior **Ovolo**
 Bar Size **5/8"**
 Internal Spacers **Champagne**



Printed By: Steve Davis

Created: 5/26/2023

This report does not include Non-Kolbe Items

2023 Pricing

Window and Door Details Page 62 of 76

For warranty information please click this link or visit <https://www.kolbewindows.com/resources/warranties>

WINDOW 26, 27

Quote 1217694C: 45 W LENOX STREET

Merit Commercial Windows, Inc

6/19/2023 3:31:55 PM

Window and Door Details

Second Bar Size	None
Grid Pattern	Colonial
Colonial Divison	2W2H
Grille Division Type	Specified
Lite Bar Alignment	Align Vertical

*** Hardware-Accessories ***

Lock Style	Spoon
Hardware Color	Antique Brass
Bottom Sash Lift Handle(s)	No
Screen	Half Screen
Mesh Type	BetterVue Fiberglass
Screen(s) Applied	No
Ogee Lugs	No
Jambliner	Black
Window Opening Control Device	No
Class 5 Balance	No

*** Species-Finish-Color ***

Change Species	Leave All Pine
Exterior Frame Finish	70% Fluoropolymer
Exterior Sash Finish	70% Fluoropolymer
Match All Exterior Colors	Yes
Exterior Color	Ultra Pure White
Interior Frame Finish	Colored Prefinish
Interior Sash Finish	Colored Prefinish
Match All Interior Colors	Yes
Interior Color	Ultra Pure White
Jambliner Cover	Wood Wrapped
Vertical Weatherstrip Color	Black
Fingerjoints	Standard Fingerjoints



Printed By: Steve Davis

Created: 5/26/2023

This report does not include Non-Kolbe Items

2023 Pricing

Window and Door Details Page 63 of 76

For warranty information please click this link or visit <https://www.kolbewindows.com/resources/warranties>

WINDOW 26, 27

Quote 1217694C: 45 W LENOX STREET

Merit Commercial Windows, Inc

6/19/2023 3:31:55 PM

020 3RD FL RIGHT BED EA (2) 3.70 \$1,834.84 \$3,669.68

*** Unit ***

UDH (Assy 1)

Ultra Rectangle Double Hung

*** Unit ***

Unit 1.1: #1117 Vintage, Extruded Sash, Sterling, Square Basic Jamb Profile

*** Glass ***

Unit 1.1: Solar Low-E Glass

*** Lite Divisions ***

Unit 1.1 Lower: Performance Divided Lites, Colonial, Align Vertical Bars, 2W2H, 5/8" Bars, Beveled Bars - Exterior

Unit 1.1 Upper: Performance Divided Lites, Colonial, 2W2H, 5/8" Bars, Beveled Bars - Exterior

*** Hardware-Accessories ***

Unit 1.1: Antique Brass Hardware, Spoon Lock, BetterVue Fiberglass Half Screen, Screen(s) Loose

*** Species-Finish-Color ***

Unit 1.1: 70% Fluoropolymer Exterior Sash, 70% Fluoropolymer Exterior Frame, Ultra Pure White Exterior, Colored Prefinish Interior Sash, Colored Prefinish Interior Frame, Ultra Pure White Interior, Wood Wrapped Jambliner, Black Vertical Weatherstrip

*** Casing-Jambs-Trim ***

Unit 1.1: No Casing, No Sill Nosing, No Nailing Fin, 4-9/16" Jambs

AS VIEWED FROM EXTERIOR

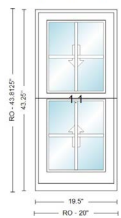

Scaled to Fit

Rough Opening:
20" X 43 13/16"

Frame Size:
19 1/2" X 43 1/4"

Unit Dimension:
19 1/2" X 43 1/4"



Printed By: Steve Davis

Created: 5/26/2023

* Indicates Increased Rough Opening

2023 Pricing

Summary Page 20 of 76

For warranty information please click this link or visit <https://www.kolbewindows.com/resources/warranties>

WINDOW 28

THIS DRAWING AND THE INFORMATION IT CONTAINS ARE THE PROPERTY OF KOLBE & KOLBE MILLWORK CO., INC. AND ARE PROPRIETARY AND CONFIDENTIAL TO KOLBE & KOLBE MILLWORK CO., INC. ANY UNAUTHORIZED PUBLICATION, COPYING, USE, REPRODUCTION, DISCLOSURE OR DISSEMINATION OF THE DRAWING OR INFORMATION BY ANY MEANS (INCLUDING ELECTRONIC MEANS) IS PROHIBITED.

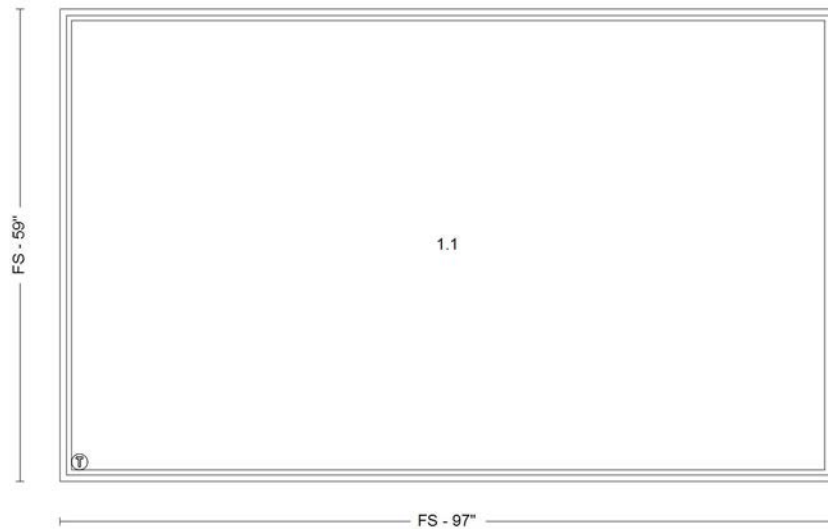

FS: 97" X 59"
 RO: 97-1/2" X 59-1/2"
 UD: 97" X 59"

Ultra Rectangle DH/SH Transom
 UTR (Assy 1)

NOT FOR PRODUCTION USE

CUSTOMER: MERIT COMMERCIAL WINDOWS, INC	LINE: 006-1	QUANTITY: 1
PRINTED BY: STEVE DAVIS	LABEL: REAR-DINING ROOM-FULL	
PROJECT: 45 W LENOX STREET		
QUOTE 1217694: 45 W LENOX STREET	PK VERSION: 759	
PRINTED: 6/19/2023 3:34 PM		

WINDOW 28

Quote 1217694C: 45 W LENOX STREET

Merit Commercial Windows, Inc

6/19/2023 3:31:55 PM

Window and Door Details

Line Number 006-1
Label REAR-DINING ROOM-FULL REPLACEMENT
Product Name Ultra Rectangle DH/SH Transom (UTR)
Configured in PK Version 759

Unit Type Complete Unit
Unit Package No Package
Model Match Sterling Profile
Frame Type Direct Set
Profile UDHDS
Production Current
Stop Profile Square

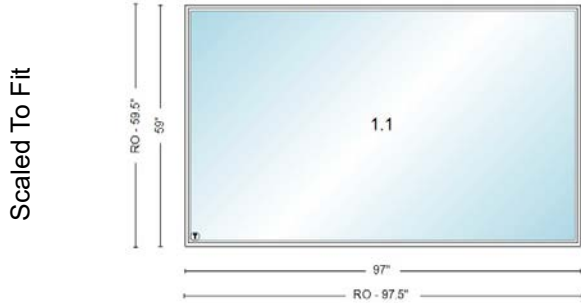

Quantity (1)
Cubic Feet 42.16
Unit Price \$3,513.91
Extended Price \$3,513.91

***** Glass *****
Glass Make Up Double Glazed
Glass Solar Low-E
Glass Spacer Mill Finish
High Altitude No
Glass Preserve / Neat+ Coating Glass Preserve without Neat+ Coating
Glass Type Clear
Obscure / Opaque Glass None
Tempered

***** Pricing Details *****
Base Price \$2,299.82
Glass \$598.46
Interior Finish \$615.63

***** Species-Finish-Color *****
Change Species Leave All Pine
Exterior Frame Finish 70% Fluoropolymer
Exterior Frame Color Ultra Pure White
Interior Frame Finish Colored Prefinish
Interior Frame Color Ultra Pure White

***** Overall Dimensions *****
Overall Frame Width 97"
Overall Frame Height 59"
Overall Rough Opening Width 97 1/2"
Overall Rough Opening Height 59 1/2"
Overall Unit Dimension Width 97"
Overall Unit Dimension Height 59"

***** Dimensions *****
Individual Frame Width 97"
Individual Frame Height 59"
Glass Width 95 3/8"
Glass Height 57 3/8"

***** Casing-Jamb-Trim *****
Exterior Casing/Accessories No Casing
Sill Nosing No Sill Nosing
Nailing Fin No
Back Priming of Frame No
Jamb Depth 4 9/16"
Installation Clips None
Kolbe Installation Consulting No

***** Performance *****
Performance Standard Performance

***** Unit *****



Printed By: Steve Davis

Created: 5/26/2023

This report does not include Non-Kolbe Items

2023 Pricing

Window and Door Details Page 35 of 76

For warranty information please click this link or visit <https://www.kolbewindows.com/resources/warranties>

005 FRONT-POWDER ROOM EA (1) 3.99 \$2,054.58 \$2,054.58

*** Unit ***
UDH (Assy 1)

Ultra Rectangle Double Hung

*** Unit ***
Unit 1.1: #1117 Vintage, Extruded Sash, Sterling, Square Basic Jamb Profile

*** Glass ***
Unit 1.1: Solar Low-E Glass

*** Lite Divisions ***
Unit 1.1 Lower: Performance Divided Lites, Colonial, Align Vertical Bars, 3W2H, 5/8" Bars, Beveled Bars - Exterior

Unit 1.1 Upper: Performance Divided Lites, Colonial, 3W2H, 5/8" Bars, Beveled Bars - Exterior

*** Hardware-Accessories ***
Unit 1.1: Antique Brass Hardware, Spoon Lock, BetterVue Fiberglass Half Screen, Screen(s) Loose

*** Species-Finish-Color ***
Unit 1.1: 70% Fluoropolymer Exterior Sash, 70% Fluoropolymer Exterior Frame, Ultra Pure White Exterior, Colored Prefinish Interior Sash, Colored Prefinish Interior Frame, Ultra Pure White Interior, Wood Wrapped Jambliner, Black Vertical Weatherstrip

*** Casing-Jambs-Trim ***
Unit 1.1: No Casing, No Sill Nosing, No Nailing Fin, 4-9/16" Jambs

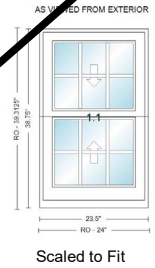

**Rough Opening:
24" X 39 5/16"**

**Frame Size:
23 1/2" X 38 3/4"**

**Unit Dimension:
23 1/2" X 38 3/4"**

006 REAR-DINING ROOM-FULL REPLACEMENT EA (1) 42.16 \$3,513.91 \$3,513.91

*** Unit ***
UTR (Assy 1)

WINDOW 28

Ultra Rectangle DH/SH Transom

*** Unit ***
Unit 1.1: Match Sterling Profile, Direct Set

*** Glass ***
Unit 1.1: Solar Low-E Glass

Unit 1.1: Tempered Glass

*** Species-Finish-Color ***
Unit 1.1: Ultra Pure White 70% Fluoropolymer Exterior Frame, Colored Prefinish Interior Frame

*** Casing-Jambs-Trim ***
Unit 1.1: No Casing, No Sill Nosing, No Nailing Fin, 4-9/16" Jambs

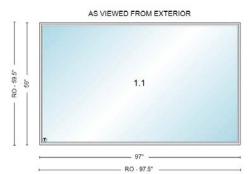

**Rough Opening:
97 1/2" X 59 1/2"**

**Frame Size:
97" X 59"**

**Unit Dimension:
97" X 59"**



WINDOW 29,30

THIS DRAWING AND THE INFORMATION IT CONTAINS ARE THE PROPERTY OF KOLBE & KOLBE MILLWORK CO., INC. AND ARE PROPRIETARY AND CONFIDENTIAL TO KOLBE & KOLBE MILLWORK CO., INC. ANY UNAUTHORIZED PUBLICATION, COPYING, USE, REPRODUCTION, DISCLOSURE OR DISSEMINATION OF THE DRAWING OR INFORMATION BY ANY MEANS (INCLUDING ELECTRONIC MEANS) IS PROHIBITED.

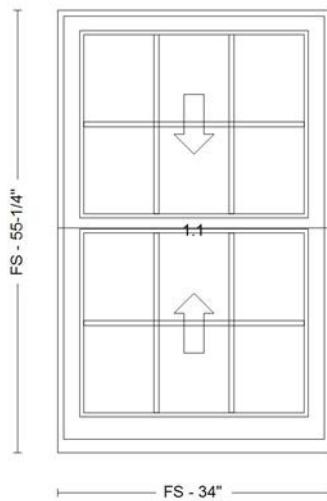

FS: 34" X 55-1/4"
 RO: 34-1/2" X 55-13/16"
 UD: 34" X 55-1/4"

Ultra Rectangle Double Hung
 UDH (Assy 1)

NOT FOR PRODUCTION USE

CUSTOMER: MERIT COMMERCIAL WINDOWS, INC	LINE: 011-1	QUANTITY: 2
PRINTED BY: STEVE DAVIS	LABEL: REAR LEFT BEDROOM	
PROJECT: 45 W LENOX STREET		
QUOTE 1217694: 45 W LENOX STREET	PK VERSION: 759	
PRINTED: 6/19/2023 3:34 PM		

WINDOW 29,30

Quote 1217694C: 45 W LENOX STREET

Merit Commercial Windows, Inc

6/19/2023 3:31:55 PM

Window and Door Details

Line Number **011-1**
 Label **REAR LEFT BEDROOM**
 Product Name **Ultra Rectangle Double Hung (UDH)**
 Configured in PK Version **759**

Scaled To Fit

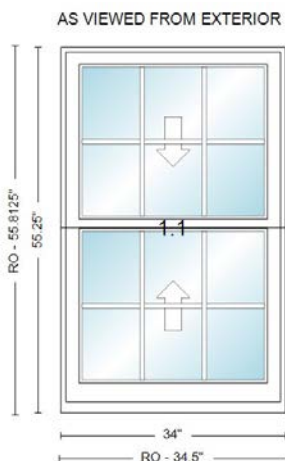

Quantity **(2)**
 Cubic Feet **9.23**
 Unit Price **\$2,381.28**
 Extended Price **\$4,762.56**

*** Pricing Details ***

Base Price **\$1,011.32**
 Lower Glass PDL **\$245.25**
 Upper Glass PDL **\$245.25**
 Screen **\$50.21**
 Non-Standard Size **\$265.13**
 Hardware Color **\$54.03**
 Lower Glass Glass **\$6.98**
 Upper Glass Glass **\$6.98**
 Screen Prep **\$34.15**
 Interior Finish **\$287.23**
 Lower Glass Lite Finish **\$87.37**
 Upper Glass Lite Finish **\$87.37**

*** Overall Dimensions ***

Overall Frame Width **34"**
 Overall Frame Height **55 1/4"**
 Overall Rough Opening Width **34 1/2"**
 Overall Rough Opening Height **55 13/16"**
 Overall Unit Dimension Width **34"**
 Overall Unit Dimension Height **55 1/4"**

*** Dimensions ***

Call Width **Custom**
 Call Height **Custom**
 Individual Frame Width **34"**
 Individual Frame Height **55 1/4"**
 Clear Opening Width **30 15/32"**
 Clear Opening Height **21 25/32"**

Glass Width **28 1/2"**
 Glass Height **23 13/32"**

*** Casing-Jamb-Trim ***

Exterior Casing/Accessories **No Casing**
 Sill Nosing **No Sill Nosing**
 Nailing Fin **No**
 Back Priming of Frame **No**
 Jamb Depth **4 9/16"**
 Installation Clips **None**
 Kolbe Installation Consulting **No**

*** Performance ***

Performance **Standard Performance**

*** Unit ***

Unit Type **Complete Unit**
 Unit Package **No Package**
 Model **Sterling**
 Production **Current**
 Vintage **#1117**
 Sash Material **Extruded**
 Basic Jamb Profile **Square**

*** Glass ***

Glass Make Up **Double Glazed**
 Glass **Solar Low-E**
 Glass Spacer **Mill Finish**
 High Altitude **No**
 Glass Preserve / Neat+ Coating **Glass Preserve without Neat+ Coating**
 Glazing Bead **Ovolo**
 Upper Glass - Glass Type **Clear**
 Upper Glass - Obscure / Opaque Glass **None**
 Upper Glass **NOT Tempered**
 Lower Glass - Glass Type **Clear**
 Lower Glass - Obscure / Opaque Glass **None**
 Lower Glass **NOT Tempered**

*** Lite Divisions - Upper ***

Lite Division **Performance Divided Lites**
 Bar Profile - Exterior **Beveled**
 Bar Profile - Interior **Ovolo**
 Bar Size **5/8"**
 Internal Spacers **Champagne**
 Second Bar Size **None**
 Grid Pattern **Colonial**
 Colonial Division **3W2H**
 Grille Division Type **Specified**

*** Lite Divisions - Lower ***

Lite Division **Performance Divided Lites**
 Bar Profile - Exterior **Beveled**
 Bar Profile - Interior **Ovolo**
 Bar Size **5/8"**
 Internal Spacers **Champagne**



Printed By: Steve Davis

Created: 5/26/2023

This report does not include Non-Kolbe Items

2023 Pricing

Window and Door Details Page 44 of 76

For warranty information please click this link or visit <https://www.kolbewindows.com/resources/warranties>

WINDOW 29,30

Quote 1217694C: 45 W LENOX STREET

Merit Commercial Windows, Inc

6/19/2023 3:31:55 PM

Window and Door Details

Second Bar Size	None
Grid Pattern	Colonial
Colonial Divison	3W2H
Grille Division Type	Specified
Lite Bar Alignment	Align Vertical

*** Hardware-Accessories ***

Lock Style	Spoon
Hardware Color	Antique Brass
Bottom Sash Lift Handle(s)	No
Screen	Half Screen
Mesh Type	BetterVue Fiberglass
Screen(s) Applied	No
Ogee Lugs	No
Jambliner	Black
Window Opening Control Device	No
Class 5 Balance	No

*** Species-Finish-Color ***

Change Species	Leave All Pine
Exterior Frame Finish	70% Fluoropolymer
Exterior Sash Finish	70% Fluoropolymer
Match All Exterior Colors	Yes
Exterior Color	Ultra Pure White
Interior Frame Finish	Colored Prefinish
Interior Sash Finish	Colored Prefinish
Match All Interior Colors	Yes
Interior Color	Ultra Pure White
Jambliner Cover	Wood Wrapped
Vertical Weatherstrip Color	Black
Fingerjoints	Standard Fingerjoints



Printed By: Steve Davis

Created: 5/26/2023

This report does not include Non-Kolbe Items

2023 Pricing

Window and Door Details Page 45 of 76

For warranty information please click this link or visit <https://www.kolbewindows.com/resources/warranties>

WINDOW 29,30

Quote 1217694C: 45 W LENOX STREET

Merit Commercial Windows, Inc

6/19/2023 3:31:55 PM

011 REAR LEFT BEDROOM EA (2) 9.23 \$2,381.28 \$4,762.56

*** Unit ***

UDH (Assy 1)

Ultra Rectangle Double Hung

*** Unit ***

Unit 1.1: #1117 Vintage, Extruded Sash, Sterling, Square Basic Jamb Profile

*** Glass ***

Unit 1.1: Solar Low-E Glass

*** Lite Divisions ***

Unit 1.1 Lower: Performance Divided Lites, Colonial, Align Vertical Bars, 3W2H, 5/8" Bars, Beveled Bars - Exterior

Unit 1.1 Upper: Performance Divided Lites, Colonial, 3W2H, 5/8" Bars, Beveled Bars - Exterior

*** Hardware-Accessories ***

Unit 1.1: Antique Brass Hardware, Spoon Lock, BetterVue Fiberglass Half Screen, Screen(s) Loose

*** Species-Finish-Color ***

Unit 1.1: 70% Fluoropolymer Exterior Sash, 70% Fluoropolymer Exterior Frame, Ultra Pure White Exterior, Colored Prefinish Interior Sash, Colored Prefinish Interior Frame, Ultra Pure White Interior, Wood Wrapped Jambliner, Black Vertical Weatherstrip

*** Casing-Jambs-Trim ***

Unit 1.1: No Casing, No Sill Nosing, No Nailing Fin, 4-9/16" Jambs

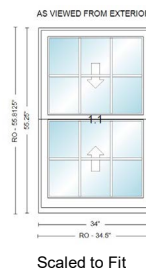

Rough Opening:
34 1/2" X 55 13/16"

Frame Size:
34" X 55 1/4"

Unit Dimension:
34" X 55 1/4"



Printed By: Steve Davis

Created: 5/26/2023

* Indicates Increased Rough Opening

2023 Pricing

Summary Page 11 of 76

For warranty information please click this link or visit <https://www.kolbewindows.com/resources/warranties>

WINDOW 31

THIS DRAWING AND THE INFORMATION IT CONTAINS ARE THE PROPERTY OF KOLBE & KOLBE MILLWORK CO., INC. AND ARE PROPRIETARY AND CONFIDENTIAL TO KOLBE & KOLBE MILLWORK CO., INC. ANY UNAUTHORIZED PUBLICATION, COPYING, USE, REPRODUCTION, DISCLOSURE OR DISSEMINATION OF THE DRAWING OR INFORMATION BY ANY MEANS (INCLUDING ELECTRONIC MEANS) IS PROHIBITED.



8/8 is intentional

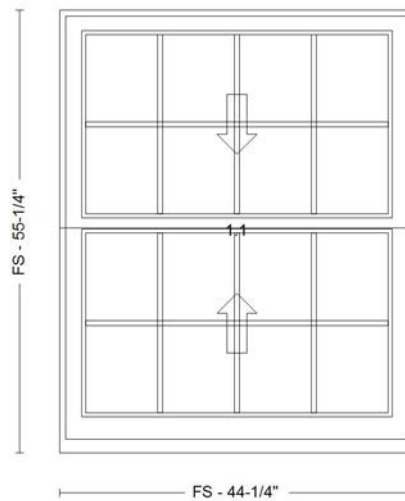

FS: 44-1/4" X 55-1/4"
 RO: 44-3/4" X 55-13/16"
 UD: 44-1/4" X 55-1/4"

Ultra Rectangle Double Hung
 UDH (Assy 1)

NOT FOR PRODUCTION USE

CUSTOMER: MERIT COMMERCIAL WINDOWS, INC	LINE: 014-1	QUANTITY: 1
PRINTED BY: STEVE DAVIS	LABEL: MASTER BEDROOM CLOSET	
PROJECT: 45 W LENOX STREET		
QUOTE 1217694: 45 W LENOX STREET	PK VERSION: 759	
PRINTED: 6/19/2023 3:34 PM		

Window and Door Details

Line Number 014-1
Label MASTER BEDROOM CLOSET
Product Name Ultra Rectangle Double Hung (UDH)
Configured in PK Version 759

Scaled To Fit

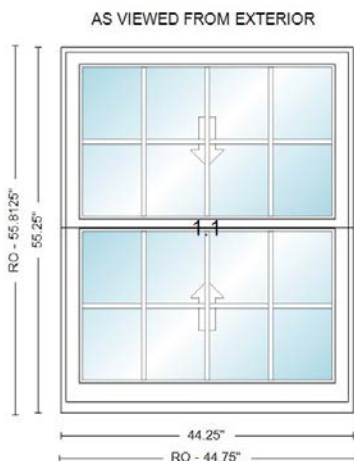

Quantity (1)
Cubic Feet 12.01
Unit Price \$2,774.46
Extended Price \$2,774.46

*** Pricing Details ***

Base Price \$1,138.87
Lower Glass PDL \$327.00
Upper Glass PDL \$327.00
Screen \$57.24
Non-Standard Size \$265.13
Hardware Color \$54.03
Lower Glass Glass \$9.34
Upper Glass Glass \$9.34
Screen Prep \$34.15
Interior Finish \$319.37
Lower Glass Lite Finish \$116.50
Upper Glass Lite Finish \$116.50

*** Overall Dimensions ***

Overall Frame Width 44 1/4"
Overall Frame Height 55 1/4"
Overall Rough Opening Width 44 3/4"
Overall Rough Opening Height 55 13/16"
Overall Unit Dimension Width 44 1/4"
Overall Unit Dimension Height 55 1/4"

*** Dimensions ***

Call Width Custom
Call Height Custom
Individual Frame Width 44 1/4"
Individual Frame Height 55 1/4"
Clear Opening Width 40 23/32"
Clear Opening Height 21 25/32"

Glass Width 38 3/4"
Glass Height 23 13/32"

*** Casing-Jamb-Trim ***

Exterior Casing/Accessories No Casing
Sill Nosing No Sill Nosing
Nailing Fin No
Back Priming of Frame No
Jamb Depth 4 9/16"
Installation Clips None
Kolbe Installation Consulting No

*** Performance ***

Performance Standard Performance

*** Unit ***

Unit Type Complete Unit
Unit Package No Package
Model Sterling
Production Current
Vintage #1117
Sash Material Extruded
Basic Jamb Profile Square

*** Glass ***

Glass Make Up Double Glazed
Glass Solar Low-E
Glass Spacer Mill Finish
High Altitude No
Glass Preserve / Neat+ Coating Glass Preserve without Neat+ Coating
Glazing Bead Ovolo
Upper Glass - Glass Type Clear
Upper Glass - Obscure / Opaque Glass None
Upper Glass NOT Tempered
Lower Glass - Glass Type Clear
Lower Glass - Obscure / Opaque Glass None
Lower Glass NOT Tempered

*** Lite Divisions - Upper ***

Lite Division Performance Divided Lites
Bar Profile - Exterior Beveled
Bar Profile - Interior Ovolo
Bar Size 5/8"
Internal Spacers Champagne
Second Bar Size None
Grid Pattern Colonial
Colonial Division 4W2H
Grille Division Type Specified

*** Lite Divisions - Lower ***

Lite Division Performance Divided Lites
Bar Profile - Exterior Beveled
Bar Profile - Interior Ovolo
Bar Size 5/8"
Internal Spacers Champagne



Printed By: Steve Davis

Created: 5/26/2023

This report does not include Non-Kolbe Items

2023 Pricing

Window and Door Details Page 50 of 76

For warranty information please click this link or visit <https://www.kolbewindows.com/resources/warranties>

Window and Door Details

Second Bar Size	None
Grid Pattern	Colonial
Colonial Divison	4W2H
Grille Division Type	Specified
Lite Bar Alignment	Align Vertical

*** Hardware-Accessories ***

Lock Style	Spoon
Hardware Color	Antique Brass
Bottom Sash Lift Handle(s)	No
Screen	Half Screen
Mesh Type	BetterVue Fiberglass
Screen(s) Applied	No
Ogee Lugs	No
Jambliner	Black
Window Opening Control Device	No
Class 5 Balance	No

*** Species-Finish-Color ***

Change Species	Leave All Pine
Exterior Frame Finish	70% Fluoropolymer
Exterior Sash Finish	70% Fluoropolymer
Match All Exterior Colors	Yes
Exterior Color	Ultra Pure White
Interior Frame Finish	Colored Prefinish
Interior Sash Finish	Colored Prefinish
Match All Interior Colors	Yes
Interior Color	Ultra Pure White
Jambliner Cover	Wood Wrapped
Vertical Weatherstrip Color	Black
Fingerjoints	Standard Fingerjoints



WINDOW 31

Quote 1217694C: 45 W LENOX STREET

Merit Commercial Windows, Inc

6/19/2023 3:31:55 PM

014 MASTER BEDROOM CLOSET EA (1) 12.01 \$2,774.46 \$2,774.46

*** Unit ***

UDH (Assy 1)

Ultra Rectangle Double Hung

*** Unit ***

Unit 1.1: #1117 Vintage, Extruded Sash, Sterling, Square Basic Jamb Profile

*** Glass ***

Unit 1.1: Solar Low-E Glass

*** Lite Divisions ***

Unit 1.1 Lower: Performance Divided Lites, Colonial, Align Vertical Bars, 4W2H, 5/8" Bars, Beveled Bars - Exterior

Unit 1.1 Upper: Performance Divided Lites, Colonial, 4W2H, 5/8" Bars, Beveled Bars - Exterior

*** Hardware-Accessories ***

Unit 1.1: Antique Brass Hardware, Spoon Lock, BetterVue Fiberglass Half Screen, Screen(s) Loose

*** Species-Finish-Color ***

Unit 1.1: 70% Fluoropolymer Exterior Sash, 70% Fluoropolymer Exterior Frame, Ultra Pure White Exterior, Colored Prefinish Interior Sash, Colored Prefinish Interior Frame, Ultra Pure White Interior, Wood Wrapped Jambliner, Black Vertical Weatherstrip

*** Casing-Jambs-Trim ***

Unit 1.1: No Casing, No Sill Nosing, No Nailing Fin, 4-9/16" Jambs

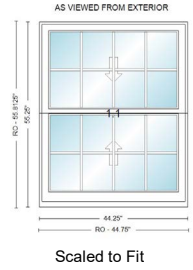

Rough Opening:
44 3/4" X 55 13/16"

Frame Size:
44 1/4" X 55 1/4"

Unit Dimension:
44 1/4" X 55 1/4"



Printed By: Steve Davis

Created: 5/26/2023

* Indicates Increased Rough Opening

2023 Pricing

Summary Page 14 of 76

For warranty information please click this link or visit <https://www.kolbewindows.com/resources/warranties>

WINDOW 32

THIS DRAWING AND THE INFORMATION IT CONTAINS ARE THE PROPERTY OF KOLBE & KOLBE MILLWORK CO., INC. AND ARE PROPRIETARY AND CONFIDENTIAL TO KOLBE & KOLBE MILLWORK CO., INC. ANY UNAUTHORIZED PUBLICATION, COPYING, USE, REPRODUCTION, DISCLOSURE OR DISSEMINATION OF THE DRAWING OR INFORMATION BY ANY MEANS (INCLUDING ELECTRONIC MEANS) IS PROHIBITED.



8/8 is intentional

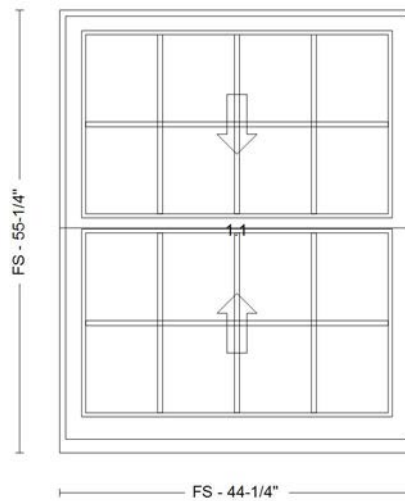

FS: 44-1/4" X 55-1/4"
 RO: 44-3/4" X 55-13/16"
 UD: 44-1/4" X 55-1/4"

Ultra Rectangle Double Hung
 UDH (Assy 1)

NOT FOR PRODUCTION USE

CUSTOMER: MERIT COMMERCIAL WINDOWS, INC	LINE: 015-1	QUANTITY: 1
PRINTED BY: STEVE DAVIS	LABEL: MASTER BEDROOM CLOSET	
PROJECT: 45 W LENOX STREET		
QUOTE 1217694: 45 W LENOX STREET	PK VERSION: 759	
PRINTED: 6/19/2023 3:34 PM		

Window and Door Details

Line Number 015-1
Label MASTER BEDROOM CLOSET
Product Name Ultra Rectangle Double Hung (UDH)
Configured in PK Version 759

Scaled To Fit

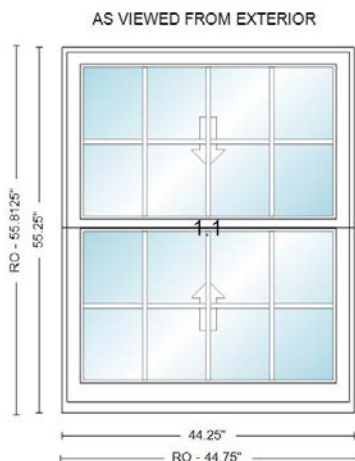

Quantity (1)
Cubic Feet 12.01
Unit Price \$2,774.46
Extended Price \$2,774.46

*** Pricing Details ***

Base Price \$1,138.87
Lower Glass PDL \$327.00
Upper Glass PDL \$327.00
Screen \$57.24
Non-Standard Size \$265.13
Hardware Color \$54.03
Lower Glass Glass \$9.34
Upper Glass Glass \$9.34
Screen Prep \$34.15
Interior Finish \$319.37
Lower Glass Lite Finish \$116.50
Upper Glass Lite Finish \$116.50

*** Overall Dimensions ***

Overall Frame Width 44 1/4"
Overall Frame Height 55 1/4"
Overall Rough Opening Width 44 3/4"
Overall Rough Opening Height 55 13/16"
Overall Unit Dimension Width 44 1/4"
Overall Unit Dimension Height 55 1/4"

*** Dimensions ***

Call Width Custom
Call Height Custom
Individual Frame Width 44 1/4"
Individual Frame Height 55 1/4"
Clear Opening Width 40 23/32"
Clear Opening Height 21 25/32"

Glass Width 38 3/4"
Glass Height 23 13/32"

*** Casing-Jamb-Trim ***

Exterior Casing/Accessories No Casing
Sill Nosing No Sill Nosing
Nailing Fin No
Back Priming of Frame No
Jamb Depth 4 9/16"
Installation Clips None
Kolbe Installation Consulting No

*** Performance ***

Performance Standard Performance

*** Unit ***

Unit Type Complete Unit
Unit Package No Package
Model Sterling
Production Current
Vintage #1117
Sash Material Extruded
Basic Jamb Profile Square

*** Glass ***

Glass Make Up Double Glazed
Glass Solar Low-E
Glass Spacer Mill Finish
High Altitude No
Glass Preserve / Neat+ Coating Glass Preserve without Neat+ Coating
Glazing Bead Ovolo
Upper Glass - Glass Type Clear
Upper Glass - Obscure / Opaque Glass None
Upper Glass NOT Tempered
Lower Glass - Glass Type Clear
Lower Glass - Obscure / Opaque Glass None
Lower Glass NOT Tempered

*** Lite Divisions - Upper ***

Lite Division Performance Divided Lites
Bar Profile - Exterior Beveled
Bar Profile - Interior Ovolo
Bar Size 5/8"
Internal Spacers Champagne
Second Bar Size None
Grid Pattern Colonial
Colonial Division 4W2H
Grille Division Type Specified

*** Lite Divisions - Lower ***

Lite Division Performance Divided Lites
Bar Profile - Exterior Beveled
Bar Profile - Interior Ovolo
Bar Size 5/8"
Internal Spacers Champagne



Window and Door Details

Second Bar Size	None
Grid Pattern	Colonial
Colonial Divison	4W2H
Grille Division Type	Specified
Lite Bar Alignment	Align Vertical

*** Hardware-Accessories ***

Lock Style	Spoon
Hardware Color	Antique Brass
Bottom Sash Lift Handle(s)	No
Screen	Half Screen
Mesh Type	BetterVue Fiberglass
Screen(s) Applied	No
Ogee Lugs	No
Jambliner	Black
Window Opening Control Device	No
Class 5 Balance	No

*** Species-Finish-Color ***

Change Species	Leave All Pine
Exterior Frame Finish	70% Fluoropolymer
Exterior Sash Finish	70% Fluoropolymer
Match All Exterior Colors	Yes
Exterior Color	Ultra Pure White
Interior Frame Finish	Colored Prefinish
Interior Sash Finish	Colored Prefinish
Match All Interior Colors	Yes
Interior Color	Ultra Pure White
Jambliner Cover	Wood Wrapped
Vertical Weatherstrip Color	Black
Fingerjoints	Standard Fingerjoints



WINDOW 32

Quote 1217694C: 45 W LENOX STREET

Merit Commercial Windows, Inc

6/19/2023 3:31:55 PM

015 MASTER BEDROOM CLOSET EA (1) 12.01 \$2,774.46 \$2,774.46

*** Unit ***

UDH (Assy 1)

Ultra Rectangle Double Hung

*** Unit ***

Unit 1.1: #1117 Vintage, Extruded Sash, Sterling, Square Basic Jamb Profile

*** Glass ***

Unit 1.1: Solar Low-E Glass

*** Lite Divisions ***

Unit 1.1 Lower: Performance Divided Lites, Colonial, Align Vertical Bars, 4W2H, 5/8" Bars, Beveled Bars - Exterior

Unit 1.1 Upper: Performance Divided Lites, Colonial, 4W2H, 5/8" Bars, Beveled Bars - Exterior

*** Hardware-Accessories ***

Unit 1.1: Antique Brass Hardware, Spoon Lock, BetterVue Fiberglass Half Screen, Screen(s) Loose

*** Species-Finish-Color ***

Unit 1.1: 70% Fluoropolymer Exterior Sash, 70% Fluoropolymer Exterior Frame, Ultra Pure White Exterior, Colored Prefinish Interior Sash, Colored Prefinish Interior Frame, Ultra Pure White Interior, Wood Wrapped Jambliner, Black Vertical Weatherstrip

*** Casing-Jambs-Trim ***

Unit 1.1: No Casing, No Sill Nosing, No Nailing Fin, 4-9/16" Jambs

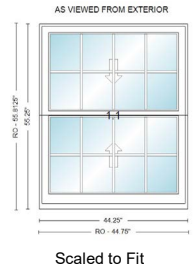

Rough Opening:
44 3/4" X 55 13/16"

Frame Size:
44 1/4" X 55 1/4"

Unit Dimension:
44 1/4" X 55 1/4"



Printed By: Steve Davis

Created: 5/26/2023

* Indicates Increased Rough Opening

2023 Pricing

Summary Page 15 of 76

For warranty information please click this link or visit <https://www.kolbewindows.com/resources/warranties>

WINDOW 33

THIS DRAWING AND THE INFORMATION IT CONTAINS ARE THE PROPERTY OF KOLBE & KOLBE MILLWORK CO., INC. AND ARE PROPRIETARY AND CONFIDENTIAL TO KOLBE & KOLBE MILLWORK CO., INC. ANY UNAUTHORIZED PUBLICATION, COPYING, USE, REPRODUCTION, DISCLOSURE OR DISSEMINATION OF THE DRAWING OR INFORMATION BY ANY MEANS (INCLUDING ELECTRONIC MEANS) IS PROHIBITED.

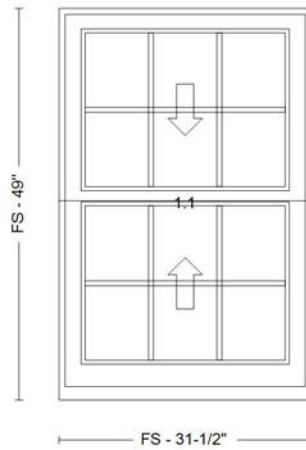

FS: 31-1/2" X 49"
 RO: 32" X 49-9/16"
 UD: 31-1/2" X 49"

Ultra Rectangle Double Hung
 UDH (Assy 1)

NOT FOR PRODUCTION USE

CUSTOMER: MERIT COMMERCIAL WINDOWS, INC	LINE: 018-1	QUANTITY: 1
PRINTED BY: STEVE DAVIS	LABEL: 3RD FLOOR LEFT BED-REAR	
PROJECT: 45 W LENOX STREET		
QUOTE 1217694: 45 W LENOX STREET	PK VERSION: 759	
PRINTED: 6/19/2023 3:34 PM		

Window and Door Details

Line Number 018-1
Label 3RD FLOOR LEFT BED-REAR
Product Name Ultra Rectangle Double Hung (UDH)
Configured in PK Version 759

Scaled To Fit

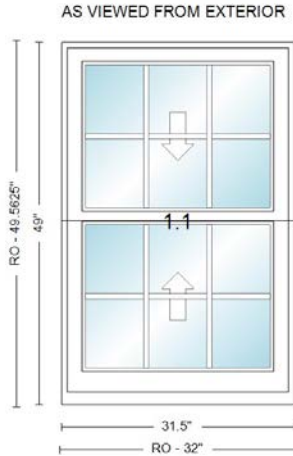

Quantity (1)
Cubic Feet 7.58
Unit Price \$2,256.74
Extended Price \$2,256.74

*** Pricing Details ***

Base Price \$922.94
Lower Glass PDL \$245.25
Upper Glass PDL \$245.25
Screen \$45.19
Non-Standard Size \$265.13
Hardware Color \$54.03
Lower Glass Glass \$5.47
Upper Glass Glass \$5.47
Screen Prep \$34.15
Interior Finish \$259.11
Lower Glass Lite Finish \$87.37
Upper Glass Lite Finish \$87.37

*** Overall Dimensions ***

Overall Frame Width 31 1/2"
Overall Frame Height 49"
Overall Rough Opening Width 32"
Overall Rough Opening Height 49 9/16"
Overall Unit Dimension Width 31 1/2"
Overall Unit Dimension Height 49"

*** Dimensions ***

Call Width Custom
Call Height Custom
Individual Frame Width 31 1/2"
Individual Frame Height 49"
Clear Opening Width 27 31/32"
Clear Opening Height 18 21/32"

Glass Width 26"
Glass Height 20 9/32"

*** Casing-Jamb-Trim ***

Exterior Casing/Accessories No Casing
 Sill Nosing No Sill Nosing
 Nailing Fin No
 Back Priming of Frame No
Jamb Depth 4 9/16"
 Installation Clips None
 Kolbe Installation Consulting No

*** Performance ***

Performance Standard Performance

*** Unit ***

Unit Type Complete Unit
 Unit Package No Package
 Model Sterling
 Production Current
 Vintage #1117
 Sash Material Extruded
 Basic Jamb Profile Square

*** Glass ***

Glass Make Up Double Glazed
 Glass Solar Low-E
 Glass Spacer Mill Finish
 High Altitude No
 Glass Preserve / Neat+ Coating Glass Preserve without Neat+ Coating
 Glazing Bead Ovolo
 Upper Glass - Glass Type Clear
 Upper Glass - Obscure / Opaque Glass None
 Upper Glass NOT Tempered
 Lower Glass - Glass Type Clear
 Lower Glass - Obscure / Opaque Glass None
 Lower Glass NOT Tempered

*** Lite Divisions - Upper ***

Lite Division Performance Divided Lites
 Bar Profile - Exterior Beveled
 Bar Profile - Interior Ovolo
 Bar Size 5/8"
 Internal Spacers Champagne
 Second Bar Size None
 Grid Pattern Colonial
 Colonial Division 3W2H
 Grille Division Type Specified

*** Lite Divisions - Lower ***

Lite Division Performance Divided Lites
 Bar Profile - Exterior Beveled
 Bar Profile - Interior Ovolo
 Bar Size 5/8"
 Internal Spacers Champagne



Window and Door Details

Second Bar Size	None
Grid Pattern	Colonial
Colonial Divison	3W2H
Grille Division Type	Specified
Lite Bar Alignment	Align Vertical

*** Hardware-Accessories ***

Lock Style	Spoon
Hardware Color	Antique Brass
Bottom Sash Lift Handle(s)	No
Screen	Half Screen
Mesh Type	BetterVue Fiberglass
Screen(s) Applied	No
Ogee Lugs	No
Jambliner	Black
Window Opening Control Device	No
Class 5 Balance	No

*** Species-Finish-Color ***

Change Species	Leave All Pine
Exterior Frame Finish	70% Fluoropolymer
Exterior Sash Finish	70% Fluoropolymer
Match All Exterior Colors	Yes
Exterior Color	Ultra Pure White
Interior Frame Finish	Colored Prefinish
Interior Sash Finish	Colored Prefinish
Match All Interior Colors	Yes
Interior Color	Ultra Pure White
Jambliner Cover	Wood Wrapped
Vertical Weatherstrip Color	Black
Fingerjoints	Standard Fingerjoints



WINDOW 33

Quote 1217694C: 45 W LENOX STREET

Merit Commercial Windows, Inc

6/19/2023 3:31:55 PM

018 3RD FLOOR LEFT BED-REAR EA (1) 7.58 \$2,256.74 \$2,256.74

*** Unit ***

UDH (Assy 1)

Ultra Rectangle Double Hung

*** Unit ***

Unit 1.1: #1117 Vintage, Extruded Sash, Sterling, Square Basic Jamb Profile

*** Glass ***

Unit 1.1: Solar Low-E Glass

*** Lite Divisions ***

Unit 1.1 Lower: Performance Divided Lites, Colonial, Align Vertical Bars, 3W2H, 5/8" Bars, Beveled Bars - Exterior

Unit 1.1 Upper: Performance Divided Lites, Colonial, 3W2H, 5/8" Bars, Beveled Bars - Exterior

*** Hardware-Accessories ***

Unit 1.1: Antique Brass Hardware, Spoon Lock, BetterVue Fiberglass Half Screen, Screen(s) Loose

*** Species-Finish-Color ***

Unit 1.1: 70% Fluoropolymer Exterior Sash, 70% Fluoropolymer Exterior Frame, Ultra Pure White Exterior, Colored Prefinish Interior Sash, Colored Prefinish Interior Frame, Ultra Pure White Interior, Wood Wrapped Jambliner, Black Vertical Weatherstrip

*** Casing-Jambs-Trim ***

Unit 1.1: No Casing, No Sill Nosing, No Nailing Fin, 4-9/16" Jambs

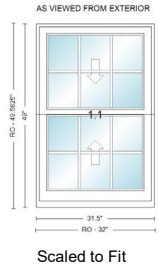

Rough Opening:
32" X 49 9/16"

Frame Size:
31 1/2" X 49"

Unit Dimension:
31 1/2" X 49"



Printed By: Steve Davis

Created: 5/26/2023

* Indicates Increased Rough Opening

2023 Pricing

Summary Page 18 of 76

For warranty information please click this link or visit <https://www.kolbewindows.com/resources/warranties>

WINDOW 34

THIS DRAWING AND THE INFORMATION IT CONTAINS ARE THE PROPERTY OF KOLBE & KOLBE MILLWORK CO., INC. AND ARE PROPRIETARY AND CONFIDENTIAL TO KOLBE & KOLBE MILLWORK CO., INC. ANY UNAUTHORIZED PUBLICATION, COPYING, USE, REPRODUCTION, DISCLOSURE OR DISSEMINATION OF THE DRAWING OR INFORMATION BY ANY MEANS (INCLUDING ELECTRONIC MEANS) IS PROHIBITED.

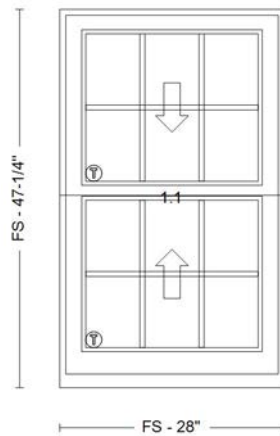

FS: 28" X 47-1/4"

RO: 28-1/2" X 47-13/16"

UD: 28" X 47-1/4"

Ultra Rectangle Double Hung
UDH (Assy 1)

NOT FOR PRODUCTION USE

CUSTOMER: MERIT COMMERCIAL WINDOWS, INC	LINE: 019-1	QUANTITY: 1
PRINTED BY: STEVE DAVIS	LABEL: 3RD FLOOR LEFT BATH	
PROJECT: 45 W LENOX STREET		
QUOTE 1217694: 45 W LENOX STREET	PK VERSION: 759	
PRINTED: 6/19/2023 3:34 PM		

WINDOW 34

Quote 1217694C: 45 W LENOX STREET

Merit Commercial Windows, Inc

6/19/2023 3:31:55 PM

Window and Door Details

Line Number **019-1**
 Label **3RD FLOOR LEFT BATH**
 Product Name **Ultra Rectangle Double Hung (UDH)**
 Configured in PK Version **759**

Scaled To Fit

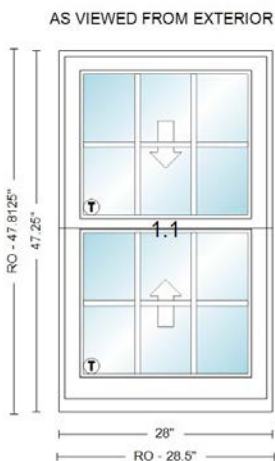

Quantity **(1)**
 Cubic Feet **5.8**
 Unit Price **\$2,284.45**
 Extended Price **\$2,284.45**

*** Pricing Details ***

Base Price **\$872.72**
 Lower Glass PDL **\$245.25**
 Upper Glass PDL **\$245.25**
 Screen **\$42.18**
 Non-Standard Size **\$265.13**
 Hardware Color **\$54.03**
 Lower Glass Glass **\$54.48**
 Upper Glass Glass **\$54.48**
 Screen Prep **\$34.15**
 Interior Finish **\$242.03**
 Lower Glass Lite Finish **\$87.37**
 Upper Glass Lite Finish **\$87.37**

*** Overall Dimensions ***

Overall Frame Width **28"**
 Overall Frame Height **47 1/4"**
 Overall Rough Opening Width **28 1/2"**
 Overall Rough Opening Height **47 13/16"**
 Overall Unit Dimension Width **28"**
 Overall Unit Dimension Height **47 1/4"**

*** Dimensions ***

Call Width **Custom**
 Call Height **Custom**
 Individual Frame Width **28"**
 Individual Frame Height **47 1/4"**
 Clear Opening Width **24 15/32"**
 Clear Opening Height **17 25/32"**

Glass Width **22 1/2"**
 Glass Height **19 13/32"**

*** Casing-Jamb-Trim ***

Exterior Casing/Accessories **No Casing**
 Sill Nosing **No Sill Nosing**
 Nailing Fin **No**
 Back Priming of Frame **No**
 Jamb Depth **4 9/16"**
 Installation Clips **None**
 Kolbe Installation Consulting **No**

*** Performance ***

Performance **Standard Performance**

*** Unit ***

Unit Type **Complete Unit**
 Unit Package **No Package**
 Model **Sterling**
 Production **Current**
 Vintage **#1117**
 Sash Material **Extruded**
 Basic Jamb Profile **Square**

*** Glass ***

Glass Make Up **Double Glazed**
 Glass **Solar Low-E**
 Glass Spacer **Mill Finish**
 High Altitude **No**
 Glass Preserve / Neat+ Coating **Glass Preserve without Neat+ Coating**
 Glazing Bead **Ovolo**
 Upper Glass - Glass Type **Clear**
 Upper Glass - Obscure / Opaque Glass **None**
 Upper Glass **Tempered**
 Lower Glass - Glass Type **Clear**
 Lower Glass - Obscure / Opaque Glass **None**
 Lower Glass **Tempered**

*** Lite Divisions - Upper ***

Lite Division **Performance Divided Lites**
 Bar Profile - Exterior **Beveled**
 Bar Profile - Interior **Ovolo**
 Bar Size **5/8"**
 Internal Spacers **Champagne**
 Second Bar Size **None**
 Grid Pattern **Colonial**
 Colonial Division **3W2H**
 Grille Division Type **Specified**

*** Lite Divisions - Lower ***

Lite Division **Performance Divided Lites**
 Bar Profile - Exterior **Beveled**
 Bar Profile - Interior **Ovolo**
 Bar Size **5/8"**
 Internal Spacers **Champagne**



Printed By: Steve Davis

Created: 5/26/2023

This report does not include Non-Kolbe Items

2023 Pricing

Window and Door Details Page 60 of 76

For warranty information please click this link or visit <https://www.kolbewindows.com/resources/warranties>

Window and Door Details

Second Bar Size	None
Grid Pattern	Colonial
Colonial Divison	3W2H
Grille Division Type	Specified
Lite Bar Alignment	Align Vertical

*** Hardware-Accessories ***

Lock Style	Spoon
Hardware Color	Antique Brass
Bottom Sash Lift Handle(s)	No
Screen	Half Screen
Mesh Type	BetterVue Fiberglass
Screen(s) Applied	No
Ogee Lugs	No
Jambliner	Black
Window Opening Control Device	No
Class 5 Balance	No

*** Species-Finish-Color ***

Change Species	Leave All Pine
Exterior Frame Finish	70% Fluoropolymer
Exterior Sash Finish	70% Fluoropolymer
Match All Exterior Colors	Yes
Exterior Color	Ultra Pure White
Interior Frame Finish	Colored Prefinish
Interior Sash Finish	Colored Prefinish
Match All Interior Colors	Yes
Interior Color	Ultra Pure White
Jambliner Cover	Wood Wrapped
Vertical Weatherstrip Color	Black
Fingerjoints	Standard Fingerjoints



WINDOW 34

Quote 1217694C: 45 W LENOX STREET

Merit Commercial Windows, Inc

6/19/2023 3:31:55 PM

019 3RD FLOOR LEFT BATH EA (1) 5.80 \$2,284.45 \$2,284.45

*** Unit ***

UDH (Assy 1)

Ultra Rectangle Double Hung

*** Unit ***

Unit 1.1: #1117 Vintage, Extruded Sash, Sterling, Square Basic Jamb Profile

*** Glass ***

Unit 1.1: Solar Low-E Glass

Unit 1.1 Lower, 1.1 Upper: Tempered Glass

*** Lite Divisions ***

Unit 1.1 Lower: Performance Divided Lites, Colonial, Align Vertical Bars, 3W2H, 5/8" Bars, Beveled Bars - Exterior

Unit 1.1 Upper: Performance Divided Lites, Colonial, 3W2H, 5/8" Bars, Beveled Bars - Exterior

*** Hardware-Accessories ***

Unit 1.1: Antique Brass Hardware, Spoon Lock, BetterVue Fiberglass Half Screen, Screen(s) Loose

*** Species-Finish-Color ***

Unit 1.1: 70% Fluoropolymer Exterior Sash, 70% Fluoropolymer Exterior Frame, Ultra Pure White Exterior, Colored Prefinish Interior Sash, Colored Prefinish Interior Frame, Ultra Pure White Interior, Wood Wrapped Jambliner, Black Vertical Weatherstrip

*** Casing-Jambs-Trim ***

Unit 1.1: No Casing, No Sill Nosing, No Nailing Fin, 4-9/16" Jambs

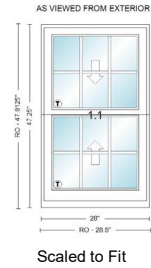

Rough Opening:
28 1/2" X 47 13/16"

Frame Size:
28" X 47 1/4"

Unit Dimension:
28" X 47 1/4"



Printed By: Steve Davis

Created: 5/26/2023

* Indicates Increased Rough Opening

2023 Pricing

Summary Page 19 of 76

For warranty information please click this link or visit <https://www.kolbewindows.com/resources/warranties>

THIS DRAWING AND THE INFORMATION IT CONTAINS ARE THE PROPERTY OF KOLBE & KOLBE MILLWORK CO., INC. AND ARE PROPRIETARY AND CONFIDENTIAL TO KOLBE & KOLBE MILLWORK CO., INC. ANY UNAUTHORIZED PUBLICATION, COPYING, USE, REPRODUCTION, DISCLOSURE OR DISSEMINATION OF THE DRAWING OR INFORMATION BY ANY MEANS (INCLUDING ELECTRONIC MEANS) IS PROHIBITED.

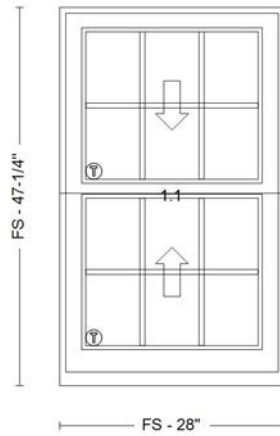

FS: 28" X 47-1/4"
 RO: 28-1/2" X 47-13/16"
 UD: 28" X 47-1/4"

Ultra Rectangle Double Hung
 UDH (Assy 1)

NOT FOR PRODUCTION USE

CUSTOMER: MERIT COMMERCIAL WINDOWS, INC	LINE: 012-1	QUANTITY: 3
PRINTED BY: STEVE DAVIS	LABEL: MASTER BATH	
PROJECT: 45 W LENOX STREET		
QUOTE 1217694: 45 W LENOX STREET	PK VERSION: 759	
PRINTED: 6/19/2023 3:34 PM		

Window and Door Details

Line Number 012-1
 Label MASTER BATH
 Product Name Ultra Rectangle Double Hung (UDH)
 Configured in PK Version 759

Scaled To Fit

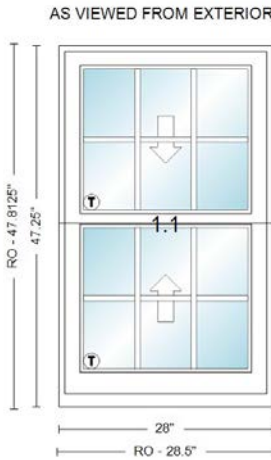

Quantity 3
 Cubic Feet 5.8
 Unit Price \$2,284.45
 Extended Price \$2,284.45

*** Pricing Details ***

Base Price \$872.72
 Lower Glass PDL \$245.25
 Upper Glass PDL \$245.25
 Screen \$42.18
 Non-Standard Size \$265.13
 Hardware Color \$54.03
 Lower Glass Glass \$54.48
 Upper Glass Glass \$54.48
 Screen Prep \$34.15
 Interior Finish \$242.03
 Lower Glass Lite Finish \$87.37
 Upper Glass Lite Finish \$87.37

*** Overall Dimensions ***

Overall Frame Width 28"
 Overall Frame Height 47 1/4"
 Overall Rough Opening Width 28 1/2"
 Overall Rough Opening Height 47 13/16"
 Overall Unit Dimension Width 28"
 Overall Unit Dimension Height 47 1/4"

*** Dimensions ***

Call Width Custom
 Call Height Custom
 Individual Frame Width 28"
 Individual Frame Height 47 1/4"
 Clear Opening Width 24 15/32"
 Clear Opening Height 17 25/32"

Glass Width 22 1/2"
 Glass Height 19 13/32"

*** Casing-Jamb-Trim ***

Exterior Casing/Accessories No Casing
 Sill Nosing No Sill Nosing
 Nailing Fin No
 Back Priming of Frame No
 Jamb Depth 4 9/16"
 Installation Clips None
 Kolbe Installation Consulting No

*** Performance ***

Performance Standard Performance

*** Unit ***

Unit Type Complete Unit
 Unit Package No Package
 Model Sterling
 Production Current
 Vintage #1117
 Sash Material Extruded
 Basic Jamb Profile Square

*** Glass ***

Glass Make Up Double Glazed
 Glass Solar Low-E
 Glass Spacer Mill Finish
 High Altitude No
 Glass Preserve / Neat+ Coating Glass Preserve without Neat+ Coating
 Glazing Bead Ovolo
 Upper Glass - Glass Type Clear
 Upper Glass - Obscure / Opaque Glass None
 Upper Glass Tempered
 Lower Glass - Glass Type Clear
 Lower Glass - Obscure / Opaque Glass None
 Lower Glass Tempered

*** Lite Divisions - Upper ***

Lite Division Performance Divided Lites
 Bar Profile - Exterior Beveled
 Bar Profile - Interior Ovolo
 Bar Size 5/8"
 Internal Spacers Champagne
 Second Bar Size None
 Grid Pattern Colonial
 Colonial Division 3W2H
 Grille Division Type Specified

*** Lite Divisions - Lower ***

Lite Division Performance Divided Lites
 Bar Profile - Exterior Beveled
 Bar Profile - Interior Ovolo
 Bar Size 5/8"
 Internal Spacers Champagne



Window and Door Details

Second Bar Size	None
Grid Pattern	Colonial
Colonial Divison	3W2H
Grille Division Type	Specified
Lite Bar Alignment	Align Vertical
*** Hardware-Accessories ***	
Lock Style	Spoon
Hardware Color	Antique Brass
Bottom Sash Lift Handle(s)	No
Screen	Half Screen
Mesh Type	BetterVue Fiberglass
Screen(s) Applied	No
Ogee Lugs	No
Jambliner	Black
Window Opening Control Device	No
Class 5 Balance	No
*** Species-Finish-Color ***	
Change Species	Leave All Pine
Exterior Frame Finish	70% Fluoropolymer
Exterior Sash Finish	70% Fluoropolymer
Match All Exterior Colors	Yes
Exterior Color	Ultra Pure White
Interior Frame Finish	Colored Prefinish
Interior Sash Finish	Colored Prefinish
Match All Interior Colors	Yes
Interior Color	Ultra Pure White
Jambliner Cover	Wood Wrapped
Vertical Weatherstrip Color	Black
Fingerjoints	Standard Fingerjoints



012 MASTER BATH

EA 3 (P)

5.80

\$2,284.45

\$2,284.45

*** Unit ***
UDH (Assy 1)

Ultra Rectangle Double Hung

*** Unit ***
Unit 1.1: #1117 Vintage, Extruded Sash, Sterling, Square Basic Jamb Profile

*** Glass ***
Unit 1.1: Solar Low-E Glass

Unit 1.1 Lower, 1.1 Upper: Tempered Glass

*** Lite Divisions ***
Unit 1.1 Lower: Performance Divided Lites, Colonial, Align Vertical Bars, 3W2H, 5/8" Bars, Beveled Bars - Exterior

Unit 1.1 Upper: Performance Divided Lites, Colonial, 3W2H, 5/8" Bars, Beveled Bars - Exterior

*** Hardware-Accessories ***
Unit 1.1: Antique Brass Hardware, Spoon Lock, BetterVue Fiberglass Half Screen, Screen(s) Loose

*** Species-Finish-Color ***
Unit 1.1: 70% Fluoropolymer Exterior Sash, 70% Fluoropolymer Exterior Frame, Ultra Pure White Exterior, Colored Prefinish Interior Sash, Colored Prefinish Interior Frame, Ultra Pure White Interior, Wood Wrapped Jambliner, Black Vertical Weatherstrip

*** Casing-Jamb-Trim ***
Unit 1.1: No Casing, No Sill Nosing, No Nailing Fin, 4-9/16" Jamb

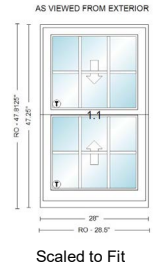

Rough Opening:
28 1/2" X 47 13/16"

Frame Size:
28" X 47 1/4"

Unit Dimension:
28" X 47 1/4"



WINDOW 38, 39, 40

THIS DRAWING AND THE INFORMATION IT CONTAINS ARE THE PROPERTY OF KOLBE & KOLBE MILLWORK CO., INC. AND ARE PROPRIETARY AND CONFIDENTIAL TO KOLBE & KOLBE MILLWORK CO., INC. ANY UNAUTHORIZED PUBLICATION, COPYING, USE, REPRODUCTION, DISCLOSURE OR DISSEMINATION OF THE DRAWING OR INFORMATION BY ANY MEANS (INCLUDING ELECTRONIC MEANS) IS PROHIBITED.

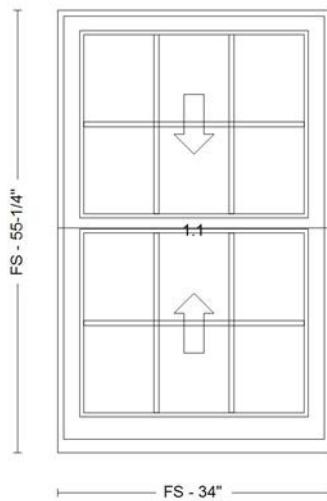

FS: 34" X 55-1/4"
 RO: 34-1/2" X 55-13/16"
 UD: 34" X 55-1/4"

Ultra Rectangle Double Hung
 UDH (Assy 1)

NOT FOR PRODUCTION USE

CUSTOMER: MERIT COMMERCIAL WINDOWS, INC	LINE: 013-1	QUANTITY: 3
PRINTED BY: STEVE DAVIS	LABEL: SIDE-MASTER BEDROOM	
PROJECT: 45 W LENOX STREET		
QUOTE 1217694: 45 W LENOX STREET	PK VERSION: 759	
PRINTED: 6/19/2023 3:34 PM		

WINDOW 38, 39, 40

Quote 1217694C: 45 W LENOX STREET

Merit Commercial Windows, Inc

6/19/2023 3:31:55 PM

Window and Door Details

Line Number **013-1**
 Label **SIDE-MASTER BEDROOM**
 Product Name **Ultra Rectangle Double Hung (UDH)**
 Configured in PK Version **759**

Scaled To Fit

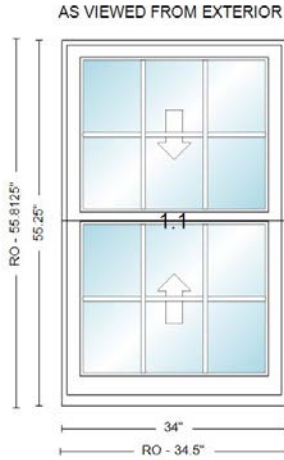

Quantity **3**
 Cubic Feet **9.23**
 Unit Price **\$2,381.28**
 Extended Price **\$2,381.28**

*** Pricing Details ***

Base Price **\$1,011.32**
 Lower Glass PDL **\$245.25**
 Upper Glass PDL **\$245.25**
 Screen **\$50.21**
 Non-Standard Size **\$265.13**
 Hardware Color **\$54.03**
 Lower Glass Glass **\$6.98**
 Upper Glass Glass **\$6.98**
 Screen Prep **\$34.15**
 Interior Finish **\$287.23**
 Lower Glass Lite Finish **\$87.37**
 Upper Glass Lite Finish **\$87.37**

*** Overall Dimensions ***

Overall Frame Width **34"**
 Overall Frame Height **55 1/4"**
 Overall Rough Opening Width **34 1/2"**
 Overall Rough Opening Height **55 13/16"**
 Overall Unit Dimension Width **34"**
 Overall Unit Dimension Height **55 1/4"**

*** Dimensions ***

Call Width **Custom**
 Call Height **Custom**
 Individual Frame Width **34"**
 Individual Frame Height **55 1/4"**
 Clear Opening Width **30 15/32"**
 Clear Opening Height **21 25/32"**

Glass Width **28 1/2"**
 Glass Height **23 13/32"**

*** Casing-Jamb-Trim ***

Exterior Casing/Accessories **No Casing**
 Sill Nosing **No Sill Nosing**
 Nailing Fin **No**
 Back Priming of Frame **No**
 Jamb Depth **4 9/16"**
 Installation Clips **None**
 Kolbe Installation Consulting **No**

*** Performance ***

Performance **Standard Performance**

*** Unit ***

Unit Type **Complete Unit**
 Unit Package **No Package**
 Model **Sterling**
 Production **Current**
 Vintage **#1117**
 Sash Material **Extruded**
 Basic Jamb Profile **Square**

*** Glass ***

Glass Make Up **Double Glazed**
 Glass **Solar Low-E**
 Glass Spacer **Mill Finish**
 High Altitude **No**
 Glass Preserve / Neat+ Coating **Glass Preserve without Neat+ Coating**
 Glazing Bead **Ovolo**
 Upper Glass - Glass Type **Clear**
 Upper Glass - Obscure / Opaque Glass **None**
 Upper Glass **NOT Tempered**
 Lower Glass - Glass Type **Clear**
 Lower Glass - Obscure / Opaque Glass **None**
 Lower Glass **NOT Tempered**

*** Lite Divisions - Upper ***

Lite Division **Performance Divided Lites**
 Bar Profile - Exterior **Beveled**
 Bar Profile - Interior **Ovolo**
 Bar Size **5/8"**
 Internal Spacers **Champagne**
 Second Bar Size **None**
 Grid Pattern **Colonial**
 Colonial Division **3W2H**
 Grille Division Type **Specified**

*** Lite Divisions - Lower ***

Lite Division **Performance Divided Lites**
 Bar Profile - Exterior **Beveled**
 Bar Profile - Interior **Ovolo**
 Bar Size **5/8"**
 Internal Spacers **Champagne**



Printed By: Steve Davis

Created: 5/26/2023

This report does not include Non-Kolbe Items

2023 Pricing

Window and Door Details Page 48 of 76

For warranty information please click this link or visit <https://www.kolbewindows.com/resources/warranties>

WINDOW 38, 39, 40

Quote 1217694C: 45 W LENOX STREET

Merit Commercial Windows, Inc

6/19/2023 3:31:55 PM

Window and Door Details

Second Bar Size	None
Grid Pattern	Colonial
Colonial Divison	3W2H
Grille Division Type	Specified
Lite Bar Alignment	Align Vertical

*** Hardware-Accessories ***

Lock Style	Spoon
Hardware Color	Antique Brass
Bottom Sash Lift Handle(s)	No
Screen	Half Screen
Mesh Type	BetterVue Fiberglass
Screen(s) Applied	No
Ogee Lugs	No
Jambliner	Black
Window Opening Control Device	No
Class 5 Balance	No

*** Species-Finish-Color ***

Change Species	Leave All Pine
Exterior Frame Finish	70% Fluoropolymer
Exterior Sash Finish	70% Fluoropolymer
Match All Exterior Colors	Yes
Exterior Color	Ultra Pure White
Interior Frame Finish	Colored Prefinish
Interior Sash Finish	Colored Prefinish
Match All Interior Colors	Yes
Interior Color	Ultra Pure White
Jambliner Cover	Wood Wrapped
Vertical Weatherstrip Color	Black
Fingerjoints	Standard Fingerjoints



Printed By: Steve Davis

Created: 5/26/2023

This report does not include Non-Kolbe Items

2023 Pricing

Window and Door Details Page 49 of 76

For warranty information please click this link or visit <https://www.kolbewindows.com/resources/warranties>

WINDOW 38, 39, 40

Quote 1217694C: 45 W LENOX STREET

Merit Commercial Windows, Inc

6/19/2023 3:31:55 PM

013 SIDE-MASTER BEDROOM

EA 3 

9.23

\$2,381.28

\$2,381.28

*** Unit ***

UDH (Assy 1)

Ultra Rectangle Double Hung

*** Unit ***

Unit 1.1: #1117 Vintage, Extruded Sash, Sterling, Square Basic Jamb Profile

*** Glass ***

Unit 1.1: Solar Low-E Glass

*** Lite Divisions ***

Unit 1.1 Lower: Performance Divided Lites, Colonial, Align Vertical Bars, 3W2H, 5/8" Bars, Beveled Bars - Exterior

Unit 1.1 Upper: Performance Divided Lites, Colonial, 3W2H, 5/8" Bars, Beveled Bars - Exterior

*** Hardware-Accessories ***

Unit 1.1: Antique Brass Hardware, Spoon Lock, BetterVue Fiberglass Half Screen, Screen(s) Loose

*** Species-Finish-Color ***

Unit 1.1: 70% Fluoropolymer Exterior Sash, 70% Fluoropolymer Exterior Frame, Ultra Pure White Exterior, Colored Prefinish Interior Sash, Colored Prefinish Interior Frame, Ultra Pure White Interior, Wood Wrapped Jambliner, Black Vertical Weatherstrip

*** Casing-Jambs-Trim ***

Unit 1.1: No Casing, No Sill Nosing, No Nailing Fin, 4-9/16" Jambs

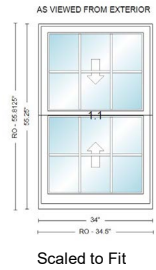

Rough Opening:
34 1/2" X 55 13/16"

Frame Size:
34" X 55 1/4"

Unit Dimension:
34" X 55 1/4"



Printed By: Steve Davis

Created: 5/26/2023

* Indicates Increased Rough Opening

2023 Pricing

Summary Page 13 of 76

For warranty information please click this link or visit <https://www.kolbewindows.com/resources/warranties>

QUOTE #	PO #	QUOTE NAME	PROJECT	JOB NAME	CUSTOMER PO #
1657653		45 Lenox Street-Kitchen	45 Lenox Street	MMD CONSTRUCTION	

LINE #	LINE TYPE	DESCRIPTION	QTY	U/M
200-1	WindowAndDoor	PK- 352	2	EA

H3 Aluminum Clad Casement Windows 2.0 Casement Right 31.5 x 65.5

Complete Unit, CoreGuard Plus

Frame = White 001, Clad Finish = AAMA 2604, Ultra Coat White, Pine Interior, Frame Jamb Flush

Sash = White 001, Sash-Panel Clad Finish = AAMA 2604, Ultra Coat White

Low-E, Tempered Both Lites, Argon Gas, Black Warm Edge Spacer

With Unit, Hdwe = White, 14" Hinge

Full Screen Applied, White, Fiberglass Mesh

Integral Rigid Vinyl Nailing Fin, No Drip Cap

Jamb = 4-9/16"

Rough Opening: 32" X 66"
 Overall Unit: 31.5" X 65.5"
 Room Location: KITCHEN BENCH



LINE #	LINE TYPE	DESCRIPTION	QTY	U/M
300-1	WindowAndDoor	PK- 352	1	EA

H3 Aluminum Clad Casement Windows 2.0 Casement Left / Right 39 x 47.5

Complete Unit, CoreGuard Plus

Frame = White 001, Clad Finish = AAMA 2604, Ultra Coat White, Pine Interior, Mull-Frame Type = Factory Box Mull, Frame Jamb Flush

Sash = White 001, Sash-Panel Clad Finish = AAMA 2604, Ultra Coat White

Low-E, Argon Gas, Black Warm Edge Spacer

With Unit, Hdwe = White, 14" Hinge

Full Screen Applied, White, Fiberglass Mesh

Integral Rigid Vinyl Nailing Fin, Aluminum Drip Cap No/Leg Shipped Separately

Jamb = 4-9/16", Interior Mull Casing Applied

Vertical Factory Tight Mull

Rough Opening: 39.5" X 48"
 Overall Unit: 39" X 47.5"
 Room Location: KITCHEN SINK

window 41

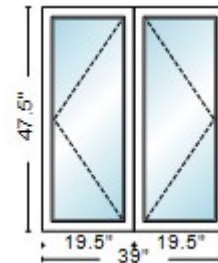

we did did changed the mullions from 7/8 back to 5/8

PERFORMANCE DIVIDED LITES



With Kolbe's performance divided lite (PDL) system, bars are adhered on the interior and exterior of an insulating glass unit and bars aligned within the unit.

PDL bars are available in various widths and patterns. They may be finished to match the exterior and/or interior, as requested.



**Beveled Profile
PDL Bars**



**Ovolo Profile PDL
Bars**



**Square Profile PDL
Bars**

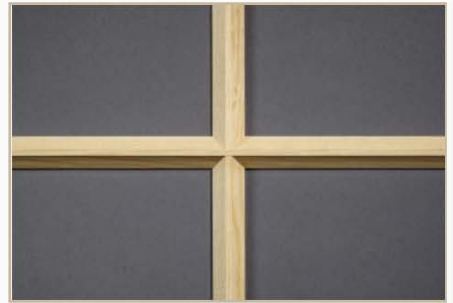

CURRENT STORMS WILL BE REMOVED WINDOW TRIM/ SHUTTERS WILL REMAIN AS EXISTING

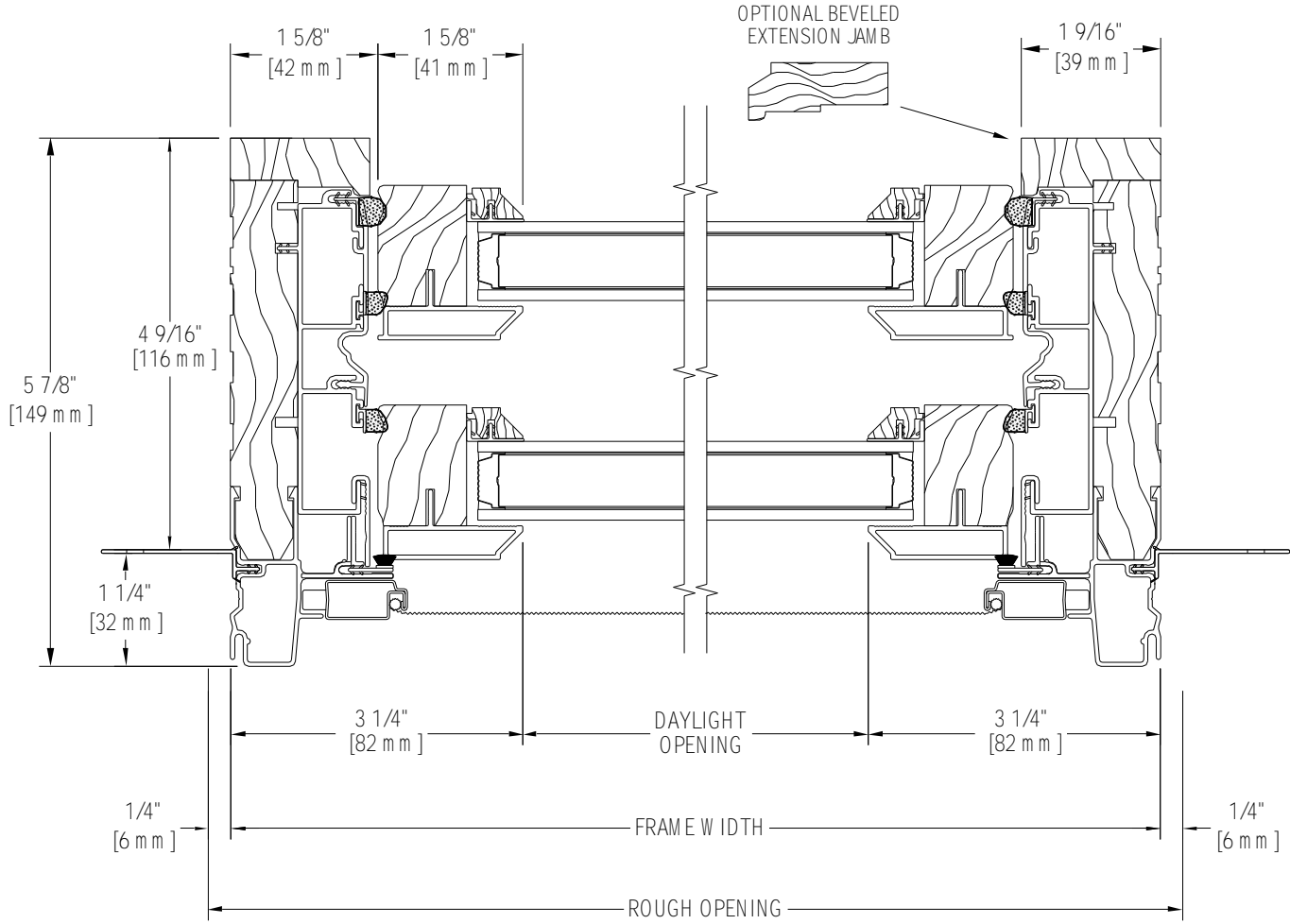

CURRENT STORMS WILL BE REMOVED WINDOW TRIM/ SHUTTERS WILL REMAIN AS EXISTING

