

EXPEDITED
MONTGOMERY COUNTY HISTORIC PRESERVATION COMMISSION
STAFF REPORT

Address:	7051 Carroll Ave., Takoma Park	Meeting Date:	1/11/2023
Resource:	Non-Contributing Resource Takoma Park Historic District	Report Date:	1/4/2023
Applicant:	Cingular Wireless Andrea Holzer, Agent	Public Notice:	12/28/2022
Review:	HAWP	Tax Credit:	n/a
Case No.:	1015296	Staff:	Dan Bruechert
Proposal:	Replacing Roof Telecommunications Equipment		

STAFF RECOMMENDATION

- Approve**
- Approve with conditions**

ARCHITECTURAL DESCRIPTION

SIGNIFICANCE: Non-Contributing Resource to the Takoma Park Historic District
STYLE: Modern
DATE: c.1970



Figure 1: The subject property is a large apartment building along Carroll Ave.

PROPOSAL

The applicant proposes to remove the existing three roof-mounted telecommunications antenna and replace it with six new antennas, and install new equipment cabinets. Because the equipment is similarly sized and on the roof of a 12-story apartment building, the visual impact on the subject property and surrounding district will be minimal.

APPLICABLE GUIDELINES**Policy On Use of Expedited Staff Reports for Simple HAWP Cases**

IV. The Expedited Staff Report format may be used on the following type of cases:

2. Modifications to a property, which do not significantly alter its visual character.

Montgomery County Code; Chapter 24A-8

- (b) The commission shall instruct the director to issue a permit, or issue a permit subject to such conditions as are found to be necessary to ensure conformity with the purposes and requirements of this chapter, if it finds that:
 - (1) The proposal will not substantially alter the exterior features of an historic site or historic resource within an historic district; or
 - (2) The proposal is compatible in character and nature with the historical, archeological, architectural or cultural features of the historic site or the historic district in which an historic resource is located and would not be detrimental thereto or to the achievement of the purposes of this chapter; or
- (d) In the case of an application for work on an historic resource located within an historic district, the commission shall be lenient in its judgment of plans for structures of little historical or design significance or for plans involving new construction, unless such plans would seriously impair the historic or architectural value of surrounding historic resources or would impair the character of the historic district. (Ord. No. 9-4, § 1; Ord. No. 11-59.)

Secretary of Interior's Standards for Rehabilitation

The Secretary of the Interior defines rehabilitation as “the act or process of making possible a compatible use for a property through repair, alterations, and additions while preserving those portions or features, which convey its historical, cultural, or architectural values.” The relevant *Standards* are as follows:

2. The historic character of a property shall be retained and preserved. The removal of historic materials or alteration of features and spaces that characterize a property shall be avoided.
9. New additions, exterior alterations, or related new construction will not destroy historic materials, features, and spatial relationships that characterize the property. The new work shall be differentiated from the old and will be compatible with the historic materials, features, size, scale and proportions, and massing to protect the integrity of the property and its environment.
10. New additions and adjacent or related new construction will be undertaken in such a manner that, if removed in the future, the essential form and integrity of the historic property and its environment would be unimpaired.

STAFF RECOMMENDATION

Staff recommends that the Commission **approve** the HAWP application under the Criteria for Issuance in Chapter 24A-8(b)(1), (2), and (d), having found that the proposal will not substantially alter the exterior features of the historic resource and is compatible in character with the district and the purposes of

Chapter 24A;

and with the *Secretary of the Interior's Standards for Rehabilitation #2, #9, and #10*;

and with the general condition that the applicant will obtain all other applicable Montgomery County or local government agency permits. After the issuance of these permits, the applicant must contact this Historic Preservation Office if any changes to the approved plan are made;

and with the general condition that final project design details, not specifically delineated by the Commission, shall be approved by HPC staff or brought back to the Commission as a revised HAWP application at staff's discretion;

and with the general condition that the applicant shall notify the Historic Preservation Staff if they propose to make **any alterations** to the approved plans. Once the work is completed the applicant will contact the staff person assigned to this application at 301-563-3400 or dan.bruechert@montgomeryplanning.org to schedule a follow-up site visit.
visit.



**APPLICATION FOR
HISTORIC AREA WORK PERMIT**
HISTORIC PRESERVATION COMMISSION
301.563.3400

FOR STAFF ONLY:
HAWP# _____
DATE ASSIGNED _____

APPLICANT:

Name: _____ E-mail: _____
Address: _____ City: _____ Zip: _____
Daytime Phone: _____ Tax Account No.: _____

AGENT/CONTACT (if applicable):

Name: _____ E-mail: _____
Address: _____ City: _____ Zip: _____
Daytime Phone: _____ Contractor Registration No.: _____

LOCATION OF BUILDING/PREMISE: MIHP # of Historic Property _____

Is the Property Located within an Historic District? Yes/District Name _____
 No/Individual Site Name _____

Is there an Historic Preservation/Land Trust/Environmental Easement on the Property? If YES, include a map of the easement, and documentation from the Easement Holder supporting this application.

Are other Planning and/or Hearing Examiner Approvals /Reviews Required as part of this Application? (Conditional Use, Variance, Record Plat, etc.?) If YES, include information on these reviews as supplemental information.

Building Number: _____ Street: _____

Town/City: _____ Nearest Cross Street: _____

Lot: _____ Block: _____ Subdivision: _____ Parcel: _____

TYPE OF WORK PROPOSED: See the checklist on Page 4 to verify that all supporting items for proposed work are submitted with this application. Incomplete Applications will not be accepted for review. Check all that apply:

- | | | |
|---|--|--|
| <input type="checkbox"/> New Construction | <input type="checkbox"/> Deck/Porch | <input type="checkbox"/> Shed/Garage/Accessory Structure |
| <input type="checkbox"/> Addition | <input type="checkbox"/> Fence | <input type="checkbox"/> Solar |
| <input type="checkbox"/> Demolition | <input type="checkbox"/> Hardscape/Landscape | <input type="checkbox"/> Tree removal/planting |
| <input type="checkbox"/> Grading/Excavation | <input type="checkbox"/> Roof | <input type="checkbox"/> Window/Door |
| | | <input type="checkbox"/> Other: _____ |

I hereby certify that I have the authority to make the foregoing application, that the application is correct and accurate and that the construction will comply with plans reviewed and approved by all necessary agencies and hereby acknowledge and accept this to be a condition for the issuance of this permit.

Signature of owner or authorized agent _____
Date

HAWP APPLICATION: MAILING ADDRESSES FOR NOTIFYING
[Owner, Owner's Agent, Adjacent and Confronting Property Owners]

Owner's mailing address	Owner's Agent's mailing address
Adjacent and confronting Property Owners mailing addresses	

Description of Property: Please describe the building and surrounding environment. Include information on significant structures, landscape features, or other significant features of the property:

Description of Work Proposed: Please give an overview of the work to be undertaken:

Work Item 1: _____	
Description of Current Condition:	Proposed Work:

Work Item 2: _____	
Description of Current Condition:	Proposed Work:

Work Item 3: _____	
Description of Current Condition:	Proposed Work:



02/22/2020 13:51



02/22/2020 13:52



02/22/2020 13:30

FIRE LANE
NO
PARKING
TOW-AWAY
ZONE

MANUFACTURER: NOKIA
 MODEL NO.: AEQK AIRSCALE MAA 64T64R 192AE n77 200w
 TECHNOLOGY: 5G CBAND
 DIMENSIONS (HxWxD): 29.53" x 17.72" x 9.53"
 WEIGHT (lbs): <99.21
 POWER SUPPLY: DC -40.5V TO -57V
 TEMP. W/O SOLAR LOAD: -40°C TO 55°C

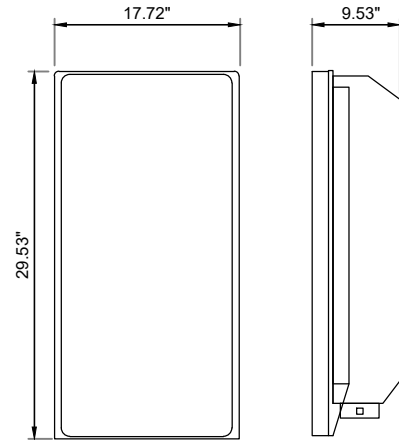

NOTE: ALL NEW ANTENNAS
 WILL BE PAINTED TO MATCH.

MANUFACTURER: NOKIA
 MODEL NO.: AEQU AIRSCALE MAA 64T64R 192AE n77 200w
 TECHNOLOGY: 5G DOD
 DIMENSIONS (HxWxD): 29.53" x 17.72" x 9.45"
 WEIGHT (lbs): <99.21
 POWER SUPPLY: DC -40.5V TO -57V
 TEMP. W/O SOLAR LOAD: -40°C TO 55°C

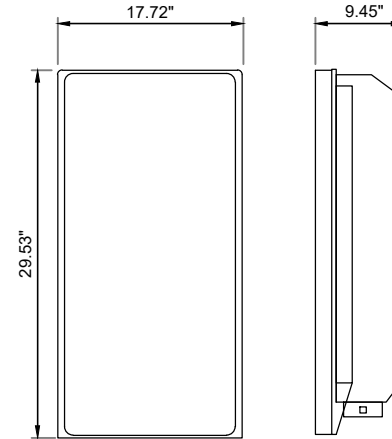

NOTE: ALL NEW ANTENNAS
 WILL BE PAINTED TO MATCH.

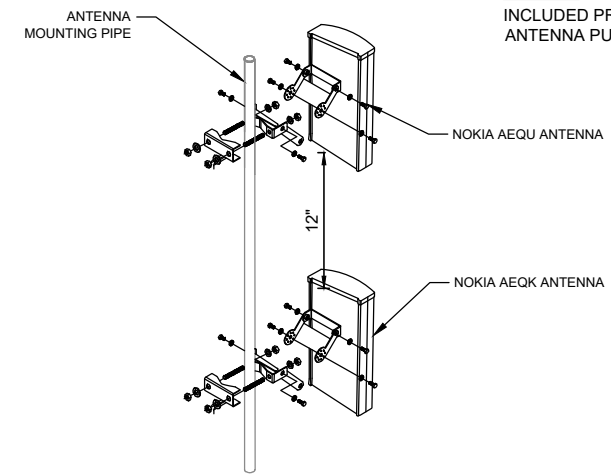

NOTE:
 INCLUDED PRODUCTS WITH
 ANTENNA PURCHASE



Jacobs
 Challenging today.
 Reinventing tomorrow.
 Jacobs Telecommunications, Inc.
 7150 STANDARD DR. SUITE B
 HANOVER, MD 21076
 443.230.4400x113

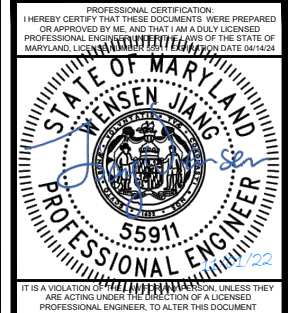

1 AEQK AIRSCALE MAA 64T64R 192AE n77 200w

SCALE: NTS

2 AEQU AIRSCALE MAA 64T64R 192AE n77 200w

SCALE: NTS

3 CBAND MOUNTING DETAIL

SCALE: NTS

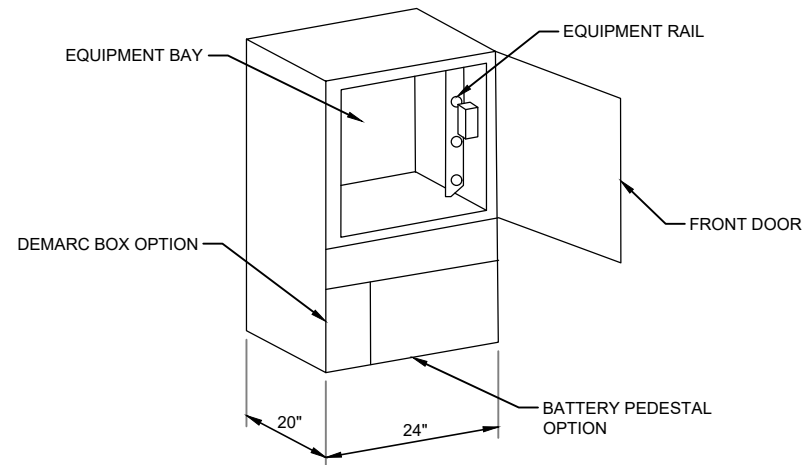

4 FLEX21-V2 CABINET

SCALE: NTS

5 DETAIL NOT USED

SCALE: NTS

6 DETAIL NOT USED

SCALE: NTS

APPROVALS

LANDLORD _____

LEASING _____

R.F. _____

ZONING _____

CONSTRUCTION _____

A & E _____

PROJECT NO: EP4TURWL

DRAWN BY: CRO

CHECKED BY: LW

SUBMITTALS	
4	11/01/22 PERMITTING COMMENTS
3	09/27/22 JX COMMENTS
2	08/23/22 ISSUED
1	06/13/22 REVISION
0	06/01/22 ISSUED
B	06/01/22 REVISION
A	04/27/22 ISSUED FOR REVIEW

THIS DOCUMENT IS THE CREATION, DESIGN, PROPERTY AND COPYRIGHTED WORK OF AT&T. WITHOUT EXPRESS WRITTEN CONSENT OF AT&T, NO PART OF THIS DOCUMENT IS TO BE REPRODUCED, COPIED, TRANSMITTED, OR IN ANY MANNER DISCLOSED TO ANY OTHER PERSON OR ENTITY. THIS DOCUMENT IS NOT TO BE USED FOR ANY OTHER PROJECT OR PURPOSE WITHOUT THE EXPRESS WRITTEN CONSENT OF AT&T.

FA# 10072888
 USID# 3939
 TULIP AVE
 7051 CARROL STREET
 TAKOMA PARK, MD 20912

SITE DETAILS

7 DETAIL NOT USED

SCALE: NTS

8 DETAIL NOT USED

SCALE: NTS

9 DETAIL NOT USED

SCALE: NTS

PASS
(59.7% Capacity)

June 27, 2022

AT&T
Steven Safire
7150 Standard Drive
Hanover, MD 21706

Jacobs
Jacobs Telecommunications, Inc.
5449 Bells Ferry Road
Acworth, GA 30102
470-785-4033
www.jacobs.com

Subject: Rooftop Equipment Installation
Mount Structural Analysis Report – Revision 1

Carrier Designation: 5G NR 1SR CBand - Parent Rooftop
Site Number: 3939
Site Name: Tulip Ave
FA Location: 10072888
PTN: 2251A12NZ6, 2251A12R24

Building Owner Designation: Takoma Tower
Site ID: NA

Engineering Firm Designation: Jacobs Telecommunications, Inc. Project: EP5TRFWL

Site Data: 7051 Carrol Street
Takoma Park, Montgomery County, MD 20912
Latitude: N38°58'29.0892"±; Longitude: W77°0'37.5732"±
Ground Elevation: 282 ft ± NAVD 88; RT: 112 ft ± AGL

Per your request, we present our structural evaluation of the antenna support frames/ mounts (manufacturer and model unknown) installed at the above referenced structure for the equipment noted in **Table B**. This analysis assumes the existing structure was properly designed and constructed, as well as being well maintained and is structurally sound.

Our work was analyzed in accordance with the structural strength requirements of the ANSI/TIA-222-H-1-2019 Structural Standard for Antenna Supporting Structures and Antennas (industry standard) the 2018 International Building Code (current building code) for the following criteria:

- 113-mph ultimate wind speed per ASCE 7-16 (Risk Category II)
- 40-mph wind speed w/ 1" ice thickness
- Exposure category C with topographic category 1

We trust you find our work satisfactory. Jacobs Telecommunications, Inc. appreciates the opportunity of providing continuing professional services to AT&T. Please do not hesitate to call should you have any questions.

Sincerely,

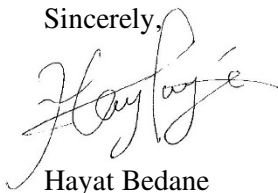

Hayat Bedane
Structural Engineer

Professional Certification. I hereby certify that these documents were prepared or approved by me, and that I am a duly licensed professional engineer under the laws of the State of Maryland, License No. 55911, Expiration Date: 4/14/24.

Wensen Jiang, PE
Engineer of Record
PE No. 55911



CONCLUSION / SUMMARY

The proposed appurtenance configuration is to be installed on the existing pipe mounts attached to the building penthouse.

Prior to installation, all rusted and deteriorated hardware is to be inspected – replace inadequate hardware as required. The antennas must be implemented on the antenna pipes such that the tip does not exceed the antenna pipes. All additional equipment (remote radio units) should be installed off the antenna mounts implemented on existing RRH sleds or directly to the wall façade on Unistrut frames.

Additionally, this analysis was completed in review of the appurtenance configuration depicted in the construction drawings such that a worse case analysis consideration for both the positioning sequence and the equipment locations was applied – the final appurtenance configuration should follow the applicable signed construction drawings for installation.

Based on our evaluation and attached calculations, the most critical structural element of the mount analyzed was observed to use no more than **59.7%** of its reduced nominal capacity; therefore, the mount is within an acceptable range to resist the stress caused by the proposed appurtenance configuration and will satisfy all assumed structural strength requirements.

It is recommended that all mounting frame members, attachment connections, and other supporting structures are thoroughly inspected prior to installation of the proposed appurtenance configuration. Any deterioration, localized damage, or distress to the structure should be documented and reported to the engineer. The contractor shall repair all deficiencies prior to installation of the proposed equipment. Additionally, the conclusions expressed herein are based solely on the information contained within the referenced documents.

Therefore, it is our opinion the mounts **are adequate** to safely support the AT&T equipment deployment and are structurally sound for the planned load. Please note that additional engineering review will be required prior to placing any future equipment.

REFERENCES

1. Mount analysis provided by B+T GRP, project no. 142211.002.01, dated 05/12/20.
2. As built provided by B+T GRP, dated 08/12/21.
3. Site walk photos dated 01/19/22.

CODE INTERPRETATIONS

Per Section 1609.1 and 3108.1 of the International Building Code, the determination of lateral loads for antenna supporting structures and antennas shall be determined using the ANSI/TIA-222.

Mount analysis procedures are based on Section 16 of the ANSI/TIA-222-H with any adjustments outlined in the Mount Technical Directive version 14 provided by AT&T. Section 16.4 directs the load combinations that are to be used for a mount analysis – included in this direction are combinations 1, 3, and 4 from Section 2.3.2.

Seismic evaluation required for sites found with Seismic Design Category D or E.

Per Section 16.3 of the ANSI/TIA-222-H, a maintenance load of $L_V = 250$ lb was considered at the worst-case cantilevered mount horizontal member and a maintenance load of $L_M = 500$ lb was considered at the worst-case mounting pipe location to determine the maximum member stress. Platform work areas are considered to have a 40 psf live area load.

Location parameters are determined from the ASCE 7 online Hazard Tool based on ASCE 7-16 per ANSI/TIA-222-H section 2.6.4.

ANALYSIS METHOD

RISA-3D (Version 17.0.1), a commercially available analysis software package, was used to create a three-dimensional model of the antenna mounting system and calculate member stresses for various loading cases. Selected output from the analysis is included.

A tool internally developed, using Microsoft Excel, by Jacobs was used to calculate wind loading on all appurtenances, dishes, and mount members for various load cases. Selected input from the analysis is included.

This analysis was performed in accordance with the SOW requirements outlined in the Mount Technical Directive version 14 provided by AT&T.

ASSUMPTIONS

The antenna mounting system was properly fabricated, installed and maintained in good condition in accordance with its original design and manufacturer's specifications.

Mounting frame members, attachment connections, and other supporting structures of the mount that cannot be determined by the referenced documents or have not been provided for this analysis, as such, Jacobs assumed typical member sizes based on known industry concepts and mount designs or previous mappings information of similar mount styles. The actual members of the mount could significantly affect the analysis; therefore, upon field verification, if member sizes are found to be different from the assumed typical member sizes, additional analyses may be required.

All member connections are assumed to have been designed to meet or exceed the load carrying capacity of the connected member unless otherwise specified in this report.

Member material grades have been assumed as follows, unless noted otherwise:

- | | |
|--------------------------------------|----------------------|
| - Channel, Solid Round, Angle, Plate | ASTM A36 (Gr 36) |
| - HSS (Rectangular) | ASTM 500 (Gr B - 46) |
| - Pipe | ASTM A53 (Gr 35) |
| - Connection Bolts | A325 |
| - U-Bolts | A307 |

DISCLAIMERS

The scope of this analysis pertains only to the antenna mount system and as such does not include examination of the loads imparted by the antenna mounting system to the tower legs and bracing members. Furthermore, no qualification is made nor implied by this document for the structural members or elements supporting the aforementioned equipment installation.

All previously installed equipment (microwaves, radios, omnis etc.) not represented in the mount loading **Table B** is to be decommissioned and removed from all antenna mounting systems or relocated to a separate detached mounting system. These installation requirements must be implemented as previously described for this assessment to be valid.

This analysis does not incorporate any rigging loads which may occur during this operation. Our analysis only includes a maintenance load as directed by the current code iteration. Nothing should be rigged using the subject antenna mount as the support.

This antenna mount is not a life support and should not be used as a life supporting system.

RESULTS

Table A: Mount Component Stresses vs. Capacity

Component	Capacity %	Pass / Fail ³
Antenna Pipe Members	59.7	Pass
Connection Members	43.2	Pass

1 – All sectors are typical.

2 – Rating per TIA-222-H, Section 15.5.

3 – A demand/capacity ration of 1.05 or less is within engineering tolerances and considered acceptable per TIA-222-H Annex S.4.

MOUNT LOADING

Table B: Existing, Proposed and Reserved Appurtenance Configuration^{1,2}

Elevation (AGL, ft)	Sector	Azimuth	Position ³	Equipment ^{4,6}			
115	Alpha	25°	1	(1) Nokia AEQK (Stacked Antenna)			
				(1) Nokia AEQU (Stacked Antenna)			
				(1) Raycap DC9-48-60-24-PC16-EV (Surge)			
			2	(1) Commscope NNHH-65A-R4 (Antenna)			
				(1) Nokia RRH 4T4R B12/14 320W AHLBA (RRH)			
				(1) Nokia RRH 4T4R B25/66 320W AHFIB (RRH)			
			3	(1) Raycap DC9-48-60-24-PC16-EV (Surge)			
				-			
				(1) Commscope NNHH-65A-R4 (Antenna)			
			4	(1) KMW KFTDR00110030 (Filter)			
				(1) Nokia RRH 4T4R B5/29 240W AHBCB (RRH)			
				(1) ALU RRH4x25-WCS-4R (RRH)			
(1) Raycap DC9-48-60-24-PC16-EV (Surge)							
129	Beta	140°	1	(1) Nokia AEQK (Stacked Antenna)			
				(1) Nokia AEQU (Stacked Antenna)			
				(1) Commscope NNHH-65A-R4 (Antenna)			
			2	(1) Nokia RRH 4T4R B12/14 320W AHLBA (RRH)			
				(1) Nokia RRH 4T4R B25/66 320W AHFIB (RRH)			
				-			
			4	(1) Commscope NNHH-65A-R4 (Antenna)			
				(1) KMW KFTDR00110030 (Filter)			
				(1) Nokia RRH 4T4R B5/29 240W AHBCB (RRH)			
				(1) ALU RRH4x25-WCS-4R (RRH)			
			107	Gamma	250°	1	(1) Nokia AEQK (Stacked Antenna)
							(1) Nokia AEQU (Stacked Antenna)
(1) Commscope NNHH-65A-R4 (Antenna)							
2	(1) Nokia RRH 4T4R B12/14 320W AHLBA (RRH)						
	(1) Nokia RRH 4T4R B25/66 320W AHFIB (RRH)						
	-						
4	(1) Commscope NNHH-65A-R4 (Antenna)						
	(1) Nokia RRH 4T4R B5/29 240W AHBCB (RRH)						
	(1) ALU RRH4x25-WCS-4R (RRH)						

1 – Appurtenance Configuration as reflected in AT&T RFDS ID 4445171, updated 2/5/2022.

- 2 – The evaluation and analysis is modeled for the worse case loading shown.
- 3 – Position 1 is defined as right-most mount location when facing structure.
- 4 – Proposed equipment shown in **bold**.
- 5 – Cable loading not considered for evaluation and analysis.
- 6 – Surge locations shown in table match the RFDS; actual surge locations are to the standoff members and evenly distributed between sectors.

ATTACHMENTS

- Mount Model
 - Rendered Graphic
 - Bending Graphic
 - Shear Graphic
 - Member Section Set Graphic
 - Member Label Graphic
- Program Input and Output
 - RISA Input
 - RISA Output
 - RISA Results
- Calculations
 - Input Appurtenance Loading
 - Input Member Loading
 - Input Loading Summary
 - ASCE Hazards Parameter Summary



Envelope Only Solution

Jacobs Telecommunicatio...

H. Bedane

EP5TRFWL - Tulip Ave

Existing Wall Mount

Page 6

May 6, 2022 at 10:26 AM

Tulip Ave Mount Frame.r3d



Code Check
(Env)

Black	No Calc
Red	> 1.0
Yellow	90-1.0
Green	75-90
Cyan	50-75
Blue	0-.50

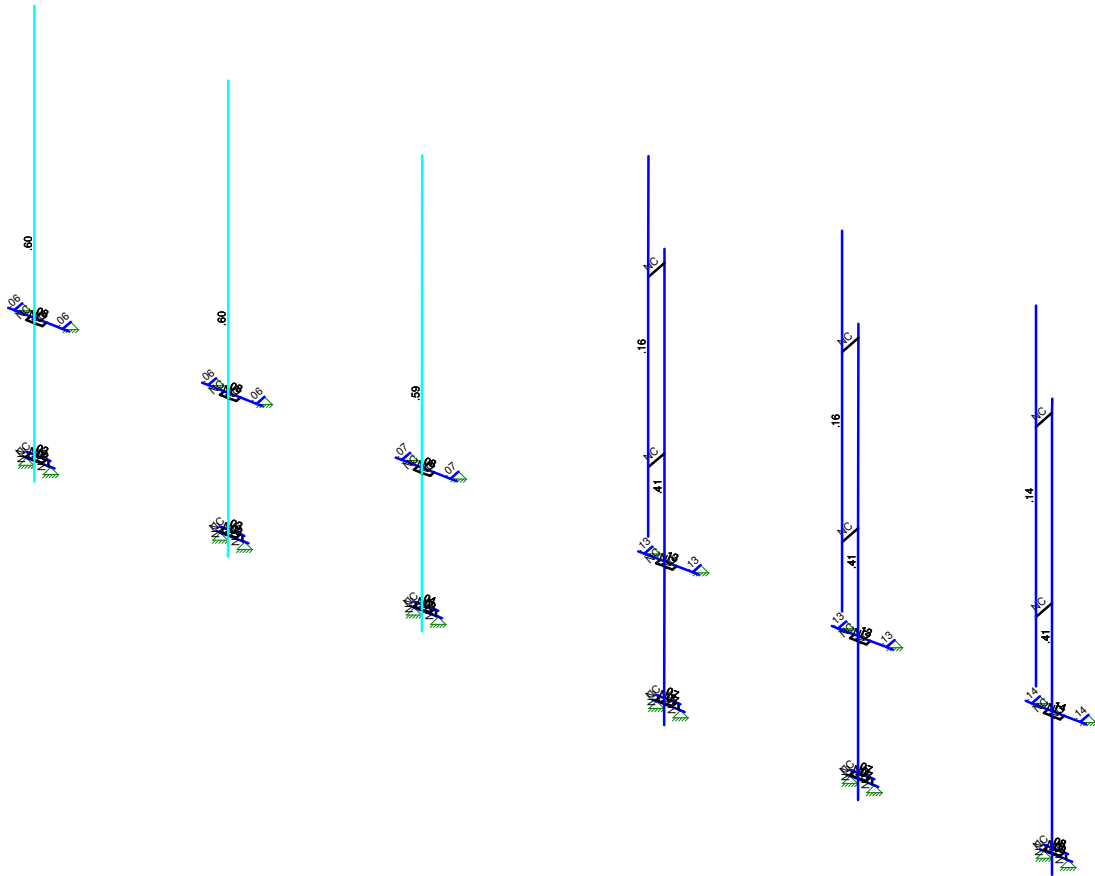

Member Code Checks Displayed (Enveloped)
Envelope Only Solution

Jacobs Telecommunicatio...

H. Bedane

EP5TRFWL - Tulip Ave

Existing Wall Mount

Page 7

May 6, 2022 at 10:26 AM

Tulip Ave Mount Frame.r3d

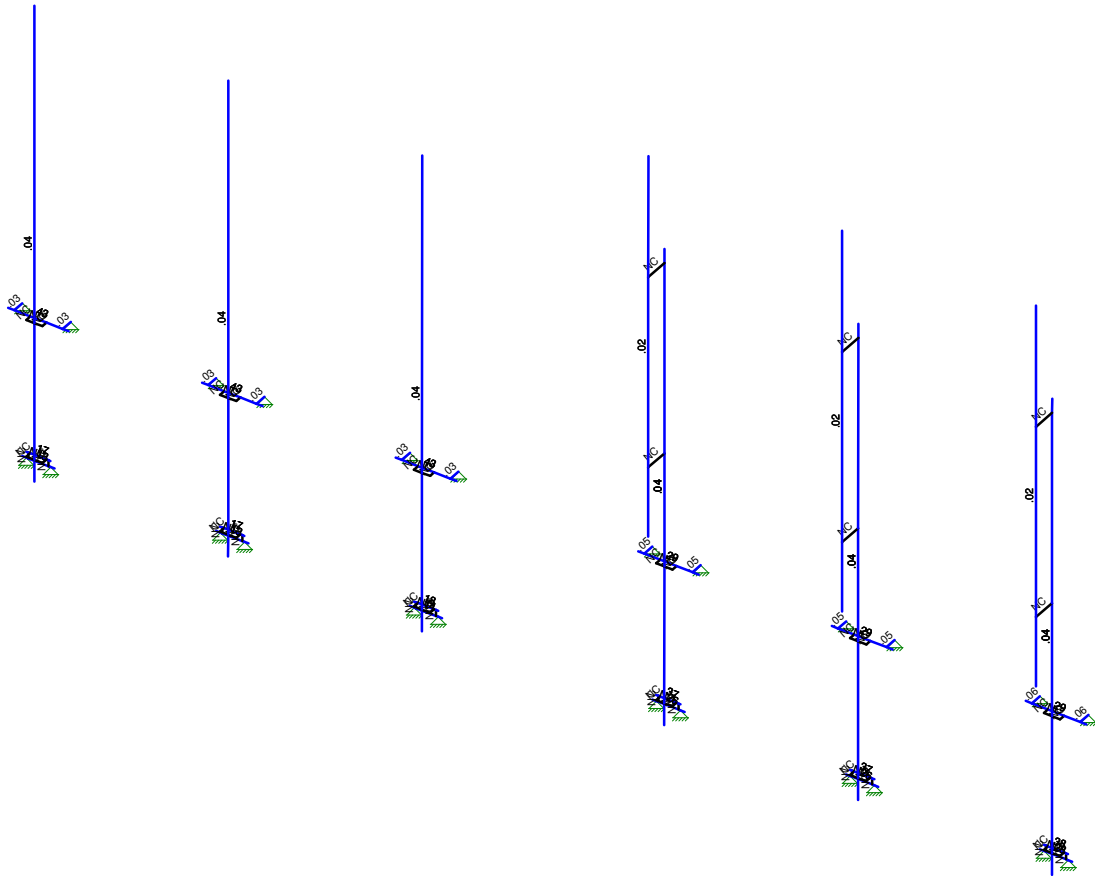
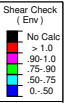

Member Shear Checks Displayed (Enveloped)
Envelope Only Solution

Jacobs Telecommunicatio...

H. Bedane

EP5TRFWL - Tulip Ave

Existing Wall Mount

Page 8

May 6, 2022 at 10:26 AM

Tulip Ave Mount Frame.r3d



Section Sets	
Antenna Pipe 1	Blue
Antenna Pipe 2	Green
Connection	Red
RIGID	Grey

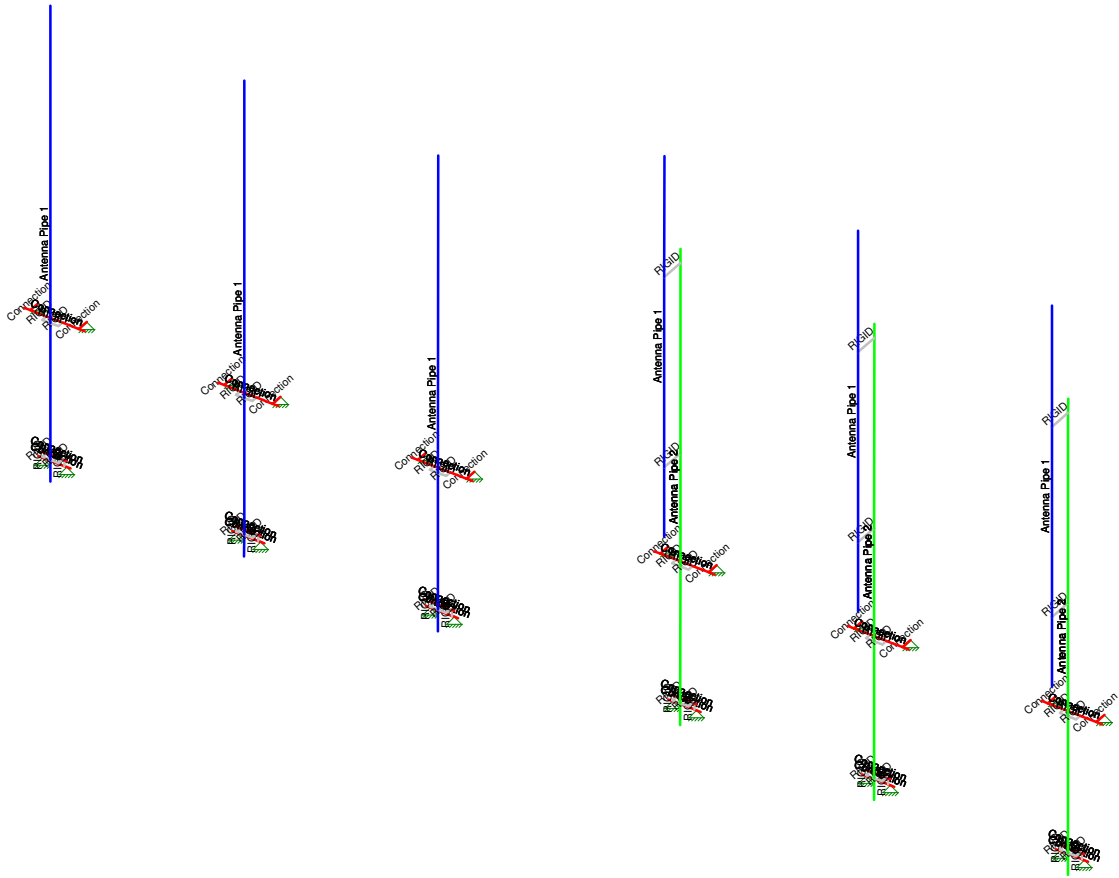

Envelope Only Solution

Jacobs Telecommunicatio...
H. Bedane
EP5TRFWL - Tulip Ave

Existing Wall Mount

Page 9

May 6, 2022 at 10:26 AM

Tulip Ave Mount Frame.r3d

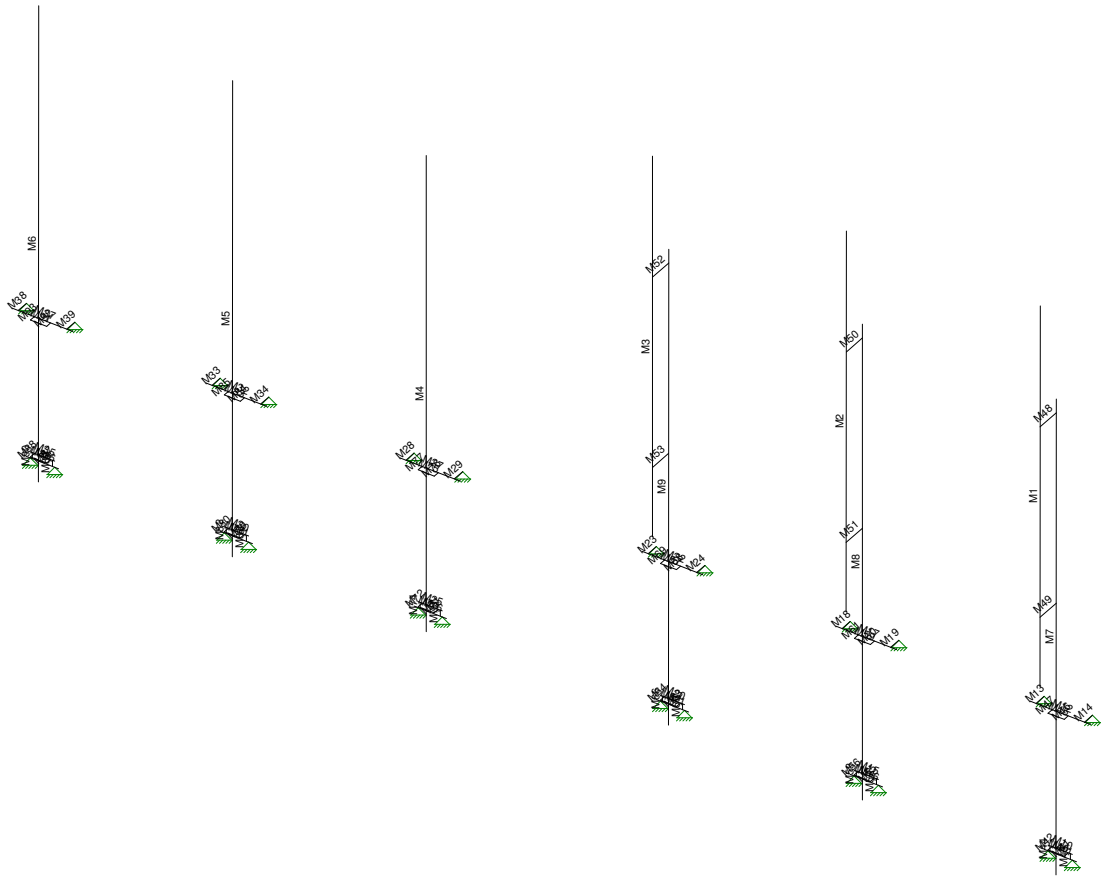

Envelope Only Solution

Jacobs Telecommunicatio...

H. Bedane

EP5TRFWL - Tulip Ave

Existing Wall Mount

Page 10

May 6, 2022 at 10:26 AM

Tulip Ave Mount Frame.r3d



Basic Load Cases

	BLC Description	Category	X Gravity	Y Gravity	Z Gravity	Joint	Point	Distribut...	Area(Me...	Surface(...
1	DEAD LOAD	None			-1		8			
2	DEAD LOAD (ICE)	None					8	9		
3	WIND LOAD (NO ICE) FRONT	None					8	9		
4	WIND LOAD (NO ICE) SIDE	None					8	9		
5	WIND LOAD (ICE) FRONT	None					8	9		
6	WIND LOAD (ICE) SIDE	None					8	9		
7	LIVE LOAD (MAN)	None					6			
8	WIND LOAD (SERVICE) FRONT	None					8	9		
9	WIND LOAD (SERVICE) SIDE	None					8	9		
10	LIVE LOAD (SERVICE)	None					6			
11	SEISMIC LOAD (VERTICAL)	None								
12	SEISMIC LOAD (LATERAL) FRO...	None								
13	SEISMIC LOAD (LATERAL) SIDE	None								
14	SEISMIC LOAD (LATERAL) FRO...	None								
15	SEISMIC LOAD (LATERAL) SIDE	None								

Load Combinations

	Description	S...	P...	S...	B...	Fa...	BLCFa...	BLCFa...	B...	Fa...	B...	Fa...	B...	Fa...	B...	Fa...	B...	Fa...	B...	Fa...		
1	DEAD LOAD	Yes	Y		1	1.4																
2	DEAD LOAD + WIND LOAD (NO I...	Yes	Y		1	1.2			3	1	4											
3	DEAD LOAD + WIND LOAD (NO I...	Yes	Y		1	1.2			3	.866	4	.5										
4	DEAD LOAD + WIND LOAD (NO I...	Yes	Y		1	1.2			3	.5	4	.866										
5	DEAD LOAD + WIND LOAD (NO I...	Yes	Y		1	1.2			3		4	1										
6	DEAD LOAD + WIND LOAD (NO I...	Yes	Y		1	1.2			3	-.5	4	.866										
7	DEAD LOAD + WIND LOAD (NO I...	Yes	Y		1	1.2			3	-.8...	4	.5										
8	DEAD LOAD + WIND LOAD (NO I...	Yes	Y		1	1.2			3	-1	4											
9	DEAD LOAD + WIND LOAD (NO I...	Yes	Y		1	1.2			3	-.8...	4	-.5										
10	DEAD LOAD + WIND LOAD (NO I...	Yes	Y		1	1.2			3	-.5	4	-.8...										
11	DEAD LOAD + WIND LOAD (NO I...	Yes	Y		1	1.2			3		4	-1										
12	DEAD LOAD + WIND LOAD (NO I...	Yes	Y		1	1.2			3	.5	4	-.8...										
13	DEAD LOAD + WIND LOAD (NO I...	Yes	Y		1	1.2			3	.866	4	-.5										
14	DEAD LOAD + DEAD LOAD (ICE)...	Yes	Y		1	1.2	2	1					5	1	6							
15	DEAD LOAD + DEAD LOAD (ICE)...	Yes	Y		1	1.2	2	1					5	.866	6	.5						
16	DEAD LOAD + DEAD LOAD (ICE)...	Yes	Y		1	1.2	2	1					5	.5	6	.866						
17	DEAD LOAD + DEAD LOAD (ICE)...	Yes	Y		1	1.2	2	1					5		6	1						
18	DEAD LOAD + DEAD LOAD (ICE)...	Yes	Y		1	1.2	2	1					5	-.5	6	.866						
19	DEAD LOAD + DEAD LOAD (ICE)...	Yes	Y		1	1.2	2	1					5	-.8...	6	.5						
20	DEAD LOAD + DEAD LOAD (ICE)...	Yes	Y		1	1.2	2	1					5	-1	6							
21	DEAD LOAD + DEAD LOAD (ICE)...	Yes	Y		1	1.2	2	1					5	-.8...	6	-.5						
22	DEAD LOAD + DEAD LOAD (ICE)...	Yes	Y		1	1.2	2	1					5	-.5	6	-.8...						
23	DEAD LOAD + DEAD LOAD (ICE)...	Yes	Y		1	1.2	2	1					5		6	-1						
24	DEAD LOAD + DEAD LOAD (ICE)...	Yes	Y		1	1.2	2	1					5	.5	6	-.8...						
25	DEAD LOAD + DEAD LOAD (ICE)...	Yes	Y		1	1.2	2	1					5	.866	6	-.5						
26	DEAD LOAD + LIVE LOAD (MAN)	Yes	Y		1	1.2											7	1.5				
27	DEAD LOAD + LIVE LOAD (SER...	Yes	Y		1	1.2													8	1	9	10 1.5
28	DEAD LOAD + LIVE LOAD (SER...	Yes	Y		1	1.2													8	.866	9	.5 10 1.5
29	DEAD LOAD + LIVE LOAD (SER...	Yes	Y		1	1.2													8	.5	9	.866 10 1.5
30	DEAD LOAD + LIVE LOAD (SER...	Yes	Y		1	1.2													8		9	1 10 1.5
31	DEAD LOAD + LIVE LOAD (SER...	Yes	Y		1	1.2													8	-.5	9	.866 10 1.5
32	DEAD LOAD + LIVE LOAD (SER...	Yes	Y		1	1.2													8	-.8...	9	.5 10 1.5
33	DEAD LOAD + LIVE LOAD (SER...	Yes	Y		1	1.2													8	-1	9	10 1.5
34	DEAD LOAD + LIVE LOAD (SER...	Yes	Y		1	1.2													8	-.8...	9	-.5 10 1.5
35	DEAD LOAD + LIVE LOAD (SER...	Yes	Y		1	1.2													8	-.5	9	-.8... 10 1.5
36	DEAD LOAD + LIVE LOAD (SER...	Yes	Y		1	1.2													8		9	-1 10 1.5

Load Combinations (Continued)

Description	S...	P...	S...	B...	Fa...	BLCFa...	BLCFa...	B...	Fa...	B...	Fa...	B...	Fa...	B...	Fa...	B...	Fa...	B...	Fa...	B...	Fa...		
37 DEAD LOAD + LIVE LOAD (SER...	Yes	Y		1	1.2												8	.5	9	-.8...	10	1.5	
38 DEAD LOAD + LIVE LOAD (SER...	Yes	Y		1	1.2												8	.866	9	-.5	10	1.5	
39 DEAD LOAD + SEISMIC LOAD (V...	Yes	Y		1	1.2	1		11	1	12	1	13		14	15								
40 DEAD LOAD + SEISMIC LOAD (V...	Yes	Y		1	1.2	1		11	1	12	.866	13	.5	14	15								
41 DEAD LOAD + SEISMIC LOAD (V...	Yes	Y		1	1.2	1		11	1	12	.5	13	.866	14	15								
42 DEAD LOAD + SEISMIC LOAD (V...	Yes	Y		1	1.2	1		11	1	12		13	1	14	15								
43 DEAD LOAD + SEISMIC LOAD (V...	Yes	Y		1	1.2	1		11	1	12	-.5	13	.866	14	15								
44 DEAD LOAD + SEISMIC LOAD (V...	Yes	Y		1	1.2	1		11	1	12	-.8...	13	.5	14	15								
45 DEAD LOAD + SEISMIC LOAD (V...	Yes	Y		1	1.2	1		11	1	12	-1	13		14	15								
46 DEAD LOAD + SEISMIC LOAD (V...	Yes	Y		1	1.2	1		11	1	12	-.8...	13	-.5	14	15								
47 DEAD LOAD + SEISMIC LOAD (V...	Yes	Y		1	1.2	1		11	1	12	-.5	13	-.8...	14	15								
48 DEAD LOAD + SEISMIC LOAD (V...	Yes	Y		1	1.2	1		11	1	12		13	-.8...	14	15								
49 DEAD LOAD + SEISMIC LOAD (V...	Yes	Y		1	1.2	1		11	1	12	.5	13	-.8...	14	15								
50 DEAD LOAD + SEISMIC LOAD (V...	Yes	Y		1	1.2	1		11	1	12	.866	13	-.5	14	15								

Joint Boundary Conditions

Joint Label	X [k/in]	Y [k/in]	Z [k/in]	X Rot.[k-ft/rad]	Y Rot.[k-ft/rad]	Z Rot.[k-ft/rad]
1 N149	Reaction	Reaction	Reaction			
2 N146	Reaction	Reaction	Reaction			
3 N34	Reaction	Reaction	Reaction			
4 N35	Reaction	Reaction	Reaction			
5 N152	Reaction	Reaction	Reaction			
6 N155	Reaction	Reaction	Reaction			
7 N45	Reaction	Reaction	Reaction			
8 N46	Reaction	Reaction	Reaction			
9 N158	Reaction	Reaction	Reaction			
10 N161	Reaction	Reaction	Reaction			
11 N56	Reaction	Reaction	Reaction			
12 N57	Reaction	Reaction	Reaction			
13 N164	Reaction	Reaction	Reaction			
14 N167	Reaction	Reaction	Reaction			
15 N67	Reaction	Reaction	Reaction			
16 N68	Reaction	Reaction	Reaction			
17 N170	Reaction	Reaction	Reaction			
18 N173	Reaction	Reaction	Reaction			
19 N78	Reaction	Reaction	Reaction			
20 N79	Reaction	Reaction	Reaction			
21 N176	Reaction	Reaction	Reaction			
22 N179	Reaction	Reaction	Reaction			
23 N89	Reaction	Reaction	Reaction			
24 N90	Reaction	Reaction	Reaction			

Hot Rolled Steel Section Sets

Label	Shape	Type	Design List	Material	Design ...	A [in2]	Iyy [in4]	Izz [in4]	J [in4]
1 Antenna Pipe 1	PIPE 2.0	Column	Pipe	A53 Gr.B	Typical	1.02	.627	.627	1.25
2 Antenna Pipe 2	PIPE 3.0	Column	Pipe	A53 Gr.B	Typical	2.07	2.85	2.85	5.69
3 Connection	L3X3X3	Beam	Single Angle	A36 Gr.36	Typical	1.09	.948	.948	.014

Member Primary Data

Label	I Joint	J Joint	K Joint	Rotate...	Section/Shape	Type	Design Li...	Material	Design Rules
1 M1	N1	N22			Antenna Pipe 1	Column	Pipe	A53 Gr.B	Typical
2 M2	N2	N23			Antenna Pipe 1	Column	Pipe	A53 Gr.B	Typical



Company : Jacobs Telecommunications, Inc.
 Designer : H. Bedane
 Job Number : EP5TRFWL - Tulip Ave
 Model Name : Existing Wall Mount

May 6, 2022
 10:25 AM
 Checked By: B. Bartlett

Member Primary Data (Continued)

	Label	I Joint	J Joint	K Joint	Rotate...	Section/Shape	Type	Design Li...	Material	Design Rules
3	M3	N3	N24			Antenna Pipe 1	Column	Pipe	A53 Gr.B	Typical
4	M4	N7	N184			Antenna Pipe 1	Column	Pipe	A53 Gr.B	Typical
5	M5	N8	N185			Antenna Pipe 1	Column	Pipe	A53 Gr.B	Typical
6	M6	N9	N186			Antenna Pipe 1	Column	Pipe	A53 Gr.B	Typical
7	M7	N4	N181			Antenna Pipe 2	Column	Pipe	A53 Gr.B	Typical
8	M8	N5	N182			Antenna Pipe 2	Column	Pipe	A53 Gr.B	Typical
9	M9	N6	N183			Antenna Pipe 2	Column	Pipe	A53 Gr.B	Typical
10	M10	N99	N91		270	Connection	Beam	Single A...	A36 Gr.36	Typical
11	M11	N150	N145		90	Connection	Beam	Single A...	A36 Gr.36	Typical
12	M12	N33	N25		180	Connection	Beam	Single A...	A36 Gr.36	Typical
13	M13	N32	N35		90	Connection	Beam	Single A...	A36 Gr.36	Typical
14	M14	N26	N34		180	Connection	Beam	Single A...	A36 Gr.36	Typical
15	M15	N108	N100		270	Connection	Beam	Single A...	A36 Gr.36	Typical
16	M16	N156	N151		90	Connection	Beam	Single A...	A36 Gr.36	Typical
17	M17	N44	N36		180	Connection	Beam	Single A...	A36 Gr.36	Typical
18	M18	N43	N46		90	Connection	Beam	Single A...	A36 Gr.36	Typical
19	M19	N37	N45		180	Connection	Beam	Single A...	A36 Gr.36	Typical
20	M20	N117	N109		270	Connection	Beam	Single A...	A36 Gr.36	Typical
21	M21	N162	N157		90	Connection	Beam	Single A...	A36 Gr.36	Typical
22	M22	N55	N47		180	Connection	Beam	Single A...	A36 Gr.36	Typical
23	M23	N54	N57		90	Connection	Beam	Single A...	A36 Gr.36	Typical
24	M24	N48	N56		180	Connection	Beam	Single A...	A36 Gr.36	Typical
25	M25	N126	N118		270	Connection	Beam	Single A...	A36 Gr.36	Typical
26	M26	N168	N163		90	Connection	Beam	Single A...	A36 Gr.36	Typical
27	M27	N66	N58		180	Connection	Beam	Single A...	A36 Gr.36	Typical
28	M28	N65	N68		90	Connection	Beam	Single A...	A36 Gr.36	Typical
29	M29	N59	N67		180	Connection	Beam	Single A...	A36 Gr.36	Typical
30	M30	N135	N127		270	Connection	Beam	Single A...	A36 Gr.36	Typical
31	M31	N174	N169		90	Connection	Beam	Single A...	A36 Gr.36	Typical
32	M32	N77	N69		180	Connection	Beam	Single A...	A36 Gr.36	Typical
33	M33	N76	N79		90	Connection	Beam	Single A...	A36 Gr.36	Typical
34	M34	N70	N78		180	Connection	Beam	Single A...	A36 Gr.36	Typical
35	M35	N144	N136		270	Connection	Beam	Single A...	A36 Gr.36	Typical
36	M36	N180	N175		90	Connection	Beam	Single A...	A36 Gr.36	Typical
37	M37	N88	N80		180	Connection	Beam	Single A...	A36 Gr.36	Typical
38	M38	N87	N90		90	Connection	Beam	Single A...	A36 Gr.36	Typical
39	M39	N81	N89		180	Connection	Beam	Single A...	A36 Gr.36	Typical
40	M40	N96	N93			RIGID	None	None	RIGID	Typical
41	M41	N93	N94			RIGID	None	None	RIGID	Typical
42	M42	N96	N97			RIGID	None	None	RIGID	Typical
43	M43	N92	N147			RIGID	None	None	RIGID	Typical
44	M44	N98	N148			RIGID	None	None	RIGID	Typical
45	M45	N30	N27			RIGID	None	None	RIGID	Typical
46	M46	N27	N28			RIGID	None	None	RIGID	Typical
47	M47	N30	N31			RIGID	None	None	RIGID	Typical
48	M48	N11	N10			RIGID	None	None	RIGID	Typical
49	M49	N17	N16			RIGID	None	None	RIGID	Typical
50	M50	N13	N12			RIGID	None	None	RIGID	Typical
51	M51	N19	N18			RIGID	None	None	RIGID	Typical
52	M52	N15	N14			RIGID	None	None	RIGID	Typical
53	M53	N21	N20			RIGID	None	None	RIGID	Typical
54	M54	N105	N102			RIGID	None	None	RIGID	Typical
55	M55	N102	N103			RIGID	None	None	RIGID	Typical
56	M56	N105	N106			RIGID	None	None	RIGID	Typical
57	M57	N101	N153			RIGID	None	None	RIGID	Typical
58	M58	N107	N154			RIGID	None	None	RIGID	Typical
59	M59	N41	N38			RIGID	None	None	RIGID	Typical



Member Primary Data (Continued)

	Label	I Joint	J Joint	K Joint	Rotate...	Section/Shape	Type	Design Li...	Material	Design Rules
60	M60	N38	N39			RIGID	None	None	RIGID	Typical
61	M61	N41	N42			RIGID	None	None	RIGID	Typical
62	M62	N114	N111			RIGID	None	None	RIGID	Typical
63	M63	N111	N112			RIGID	None	None	RIGID	Typical
64	M64	N114	N115			RIGID	None	None	RIGID	Typical
65	M65	N110	N159			RIGID	None	None	RIGID	Typical
66	M66	N116	N160			RIGID	None	None	RIGID	Typical
67	M67	N52	N49			RIGID	None	None	RIGID	Typical
68	M68	N49	N50			RIGID	None	None	RIGID	Typical
69	M69	N52	N53			RIGID	None	None	RIGID	Typical
70	M70	N123	N120			RIGID	None	None	RIGID	Typical
71	M71	N120	N121			RIGID	None	None	RIGID	Typical
72	M72	N123	N124			RIGID	None	None	RIGID	Typical
73	M73	N119	N165			RIGID	None	None	RIGID	Typical
74	M74	N125	N166			RIGID	None	None	RIGID	Typical
75	M75	N63	N60			RIGID	None	None	RIGID	Typical
76	M76	N60	N61			RIGID	None	None	RIGID	Typical
77	M77	N63	N64			RIGID	None	None	RIGID	Typical
78	M78	N132	N129			RIGID	None	None	RIGID	Typical
79	M79	N129	N130			RIGID	None	None	RIGID	Typical
80	M80	N132	N133			RIGID	None	None	RIGID	Typical
81	M81	N128	N171			RIGID	None	None	RIGID	Typical
82	M82	N134	N172			RIGID	None	None	RIGID	Typical
83	M83	N74	N71			RIGID	None	None	RIGID	Typical
84	M84	N71	N72			RIGID	None	None	RIGID	Typical
85	M85	N74	N75			RIGID	None	None	RIGID	Typical
86	M86	N141	N138			RIGID	None	None	RIGID	Typical
87	M87	N138	N139			RIGID	None	None	RIGID	Typical
88	M88	N141	N142			RIGID	None	None	RIGID	Typical
89	M89	N137	N177			RIGID	None	None	RIGID	Typical
90	M90	N143	N178			RIGID	None	None	RIGID	Typical
91	M91	N85	N82			RIGID	None	None	RIGID	Typical
92	M92	N82	N83			RIGID	None	None	RIGID	Typical
93	M93	N85	N86			RIGID	None	None	RIGID	Typical

Hot Rolled Steel Design Parameters

	Label	Shape	Length[in]	Lbyy[in]	Lbzz[in]	Lcomp to...Lcomp b...	L-tor...	Kyy	Kzz	Cb	Function
1	M1	Antenna Pipe 1	96	Segment	Segment	Lbyy		2.1	2.1		Lateral
2	M2	Antenna Pipe 1	96	Segment	Segment	Lbyy		2.1	2.1		Lateral
3	M3	Antenna Pipe 1	96	Segment	Segment	Lbyy		2.1	2.1		Lateral
4	M4	Antenna Pipe 1	120	Segment	Segment	Lbyy		2.1	2.1		Lateral
5	M5	Antenna Pipe 1	120	Segment	Segment	Lbyy		2.1	2.1		Lateral
6	M6	Antenna Pipe 1	120	Segment	Segment	Lbyy		2.1	2.1		Lateral
7	M7	Antenna Pipe 2	120	Segment	Segment	Lbyy		2.1	2.1		Lateral
8	M8	Antenna Pipe 2	120	Segment	Segment	Lbyy		2.1	2.1		Lateral
9	M9	Antenna Pipe 2	120	Segment	Segment	Lbyy		2.1	2.1		Lateral
10	M10	Connection	6	Segment	Segment	Lbyy		2.1	2.1		Lateral
11	M11	Connection	8	Segment	Segment	Lbyy		2.1	2.1		Lateral
12	M12	Connection	15	Segment	Segment	Lbyy		2.1	2.1		Lateral
13	M13	Connection	3	Segment	Segment	Lbyy		.8	.8		Lateral
14	M14	Connection	3	Segment	Segment	Lbyy		.8	.8		Lateral
15	M15	Connection	6	Segment	Segment	Lbyy		2.1	2.1		Lateral
16	M16	Connection	8	Segment	Segment	Lbyy		2.1	2.1		Lateral
17	M17	Connection	15	Segment	Segment	Lbyy		2.1	2.1		Lateral
18	M18	Connection	3	Segment	Segment	Lbyy		.8	.8		Lateral



Hot Rolled Steel Design Parameters (Continued)

Label	Shape	Length[in]	Lbyy[in]	Lbzz[in]	Lcomp to...	Lcomp b...	L-tor...	Kyy	Kzz	Cb	Function
19	M19	Connection	3	Segment	Segment	Lbyy		.8	.8		Lateral
20	M20	Connection	6	Segment	Segment	Lbyy		2.1	2.1		Lateral
21	M21	Connection	8	Segment	Segment	Lbyy		2.1	2.1		Lateral
22	M22	Connection	15	Segment	Segment	Lbyy		2.1	2.1		Lateral
23	M23	Connection	3	Segment	Segment	Lbyy		.8	.8		Lateral
24	M24	Connection	3	Segment	Segment	Lbyy		.8	.8		Lateral
25	M25	Connection	6	Segment	Segment	Lbyy		2.1	2.1		Lateral
26	M26	Connection	8	Segment	Segment	Lbyy		2.1	2.1		Lateral
27	M27	Connection	15	Segment	Segment	Lbyy		2.1	2.1		Lateral
28	M28	Connection	3	Segment	Segment	Lbyy		.8	.8		Lateral
29	M29	Connection	3	Segment	Segment	Lbyy		.8	.8		Lateral
30	M30	Connection	6	Segment	Segment	Lbyy		2.1	2.1		Lateral
31	M31	Connection	8	Segment	Segment	Lbyy		2.1	2.1		Lateral
32	M32	Connection	15	Segment	Segment	Lbyy		2.1	2.1		Lateral
33	M33	Connection	3	Segment	Segment	Lbyy		.8	.8		Lateral
34	M34	Connection	3	Segment	Segment	Lbyy		.8	.8		Lateral
35	M35	Connection	6	Segment	Segment	Lbyy		2.1	2.1		Lateral
36	M36	Connection	8	Segment	Segment	Lbyy		2.1	2.1		Lateral
37	M37	Connection	15	Segment	Segment	Lbyy		2.1	2.1		Lateral
38	M38	Connection	3	Segment	Segment	Lbyy		.8	.8		Lateral
39	M39	Connection	3	Segment	Segment	Lbyy		.8	.8		Lateral

Plate Primary Data

Label	A Joint	B Joint	C Joint	D Joint	Material	Thickness[in]
No Data to Print ...						

Member Point Loads (BLC 1 : DEAD LOAD)

	Member Label	Direction	Magnitude[lb.k-ft]	Location[in,%]
1	M1	Z	-99.21	28
2	M1	Z	-99.21	70
3	M2	Z	-67.2	48
4	M3	Z	-67.2	48
5	M4	Z	-99.21	28
6	M4	Z	-99.21	70
7	M5	Z	-67.2	48
8	M6	Z	-67.2	48

Member Point Loads (BLC 2 : DEAD LOAD (ICE))

	Member Label	Direction	Magnitude[lb.k-ft]	Location[in,%]
1	M1	Z	-73.3	28
2	M1	Z	-73.1	70
3	M2	Z	-143	48
4	M3	Z	-143	48
5	M4	Z	-73.3	28
6	M4	Z	-73.1	70
7	M5	Z	-143	48
8	M6	Z	-143	48

Member Point Loads (BLC 3 : WIND LOAD (NO ICE) FRONT)

	Member Label	Direction	Magnitude[lb.k-ft]	Location[in,%]
1	M1	X	162.7	28
2	M1	X	162.4	70
3	M2	X	339.7	48



Member Point Loads (BLC 3 : WIND LOAD (NO ICE) FRONT) (Continued)

	Member Label	Direction	Magnitude[lb.k-ft]	Location[in.%]
4	M3	X	339.7	48
5	M4	X	162.7	28
6	M4	X	162.4	70
7	M5	X	339.7	48
8	M6	X	339.7	48

Member Point Loads (BLC 4 : WIND LOAD (NO ICE) SIDE)

	Member Label	Direction	Magnitude[lb.k-ft]	Location[in.%]
1	M1	Y	89.5	28
2	M1	Y	89.1	70
3	M2	Y	156.2	48
4	M3	Y	156.2	48
5	M4	Y	89.5	28
6	M4	Y	89.1	70
7	M5	Y	156.2	48
8	M6	Y	156.2	48

Member Point Loads (BLC 5 : WIND LOAD (ICE) FRONT)

	Member Label	Direction	Magnitude[lb.k-ft]	Location[in.%]
1	M1	X	24.8	28
2	M1	X	24.8	70
3	M2	X	49.2	48
4	M3	X	49.2	48
5	M4	X	24.8	28
6	M4	X	24.8	70
7	M5	X	49.2	48
8	M6	X	49.2	48

Member Point Loads (BLC 6 : WIND LOAD (ICE) SIDE)

	Member Label	Direction	Magnitude[lb.k-ft]	Location[in.%]
1	M1	Y	14.8	28
2	M1	Y	14.7	70
3	M2	Y	25.2	48
4	M3	Y	25.2	48
5	M4	Y	14.8	28
6	M4	Y	14.7	70
7	M5	Y	25.2	48
8	M6	Y	25.2	48

Member Point Loads (BLC 7 : LIVE LOAD (MAN))

	Member Label	Direction	Magnitude[lb.k-ft]	Location[in.%]
1	M1	Z	-250	0
2	M2	Z	-250	0
3	M3	Z	-250	0
4	M4	Z	-250	0
5	M5	Z	-250	0
6	M6	Z	-250	0

Member Point Loads (BLC 8 : WIND LOAD (SERVICE) FRONT)

	Member Label	Direction	Magnitude[lb.k-ft]	Location[in.%]
1	M1	X	11.5	28
2	M1	X	11.4	70
3	M2	X	23.9	48
4	M3	X	23.9	48



Company : Jacobs Telecommunications, Inc.
 Designer : H. Bedane
 Job Number : EP5TRFWL - Tulip Ave
 Model Name : Existing Wall Mount

May 6, 2022
 10:25 AM
 Checked By: B. Bartlett

Member Point Loads (BLC 8 : WIND LOAD (SERVICE) FRONT) (Continued)

	Member Label	Direction	Magnitude[lb.k-ft]	Location[in.%]
5	M4	X	11.5	28
6	M4	X	11.4	70
7	M5	X	23.9	48
8	M6	X	23.9	48

Member Point Loads (BLC 9 : WIND LOAD (SERVICE) SIDE)

	Member Label	Direction	Magnitude[lb.k-ft]	Location[in.%]
1	M1	Y	6.3	28
2	M1	Y	6.3	70
3	M2	Y	11	48
4	M3	Y	11	48
5	M4	Y	6.3	28
6	M4	Y	6.3	70
7	M5	Y	11	48
8	M6	Y	11	48

Member Point Loads (BLC 10 : LIVE LOAD (SERVICE))

	Member Label	Direction	Magnitude[lb.k-ft]	Location[in.%]
1	M1	Z	-250	0
2	M2	Z	-250	0
3	M3	Z	-250	0
4	M4	Z	-250	0
5	M5	Z	-250	0
6	M6	Z	-250	0

Member Distributed Loads (BLC 2 : DEAD LOAD (ICE))

	Member Label	Direction	Start Magnitude[lb/in.F.ksf]	End Magnitude[lb/in.F.ksf]	Start Location[in.%]	End Location[i...]
1	M1	Z	-.526	-.526	0	0
2	M2	Z	-.526	-.526	0	0
3	M3	Z	-.526	-.526	0	0
4	M4	Z	-.526	-.526	0	0
5	M5	Z	-.526	-.526	0	0
6	M6	Z	-.526	-.526	0	0
7	M7	Z	-.711	-.711	0	0
8	M8	Z	-.711	-.711	0	0
9	M9	Z	-.711	-.711	0	0

Member Distributed Loads (BLC 3 : WIND LOAD (NO ICE) FRONT)

	Member Label	Direction	Start Magnitude[lb/in.F.ksf]	End Magnitude[lb/in.F.ksf]	Start Location[in.%]	End Location[i...]
1	M1	PX	.74	.74	0	0
2	M2	PX	.74	.74	0	0
3	M3	PX	.74	.74	0	0
4	M4	PX	.74	.74	0	0
5	M5	PX	.74	.74	0	0
6	M6	PX	.74	.74	0	0
7	M7	PX	1.089	1.089	0	0
8	M8	PX	1.089	1.089	0	0
9	M9	PX	1.089	1.089	0	0

Member Distributed Loads (BLC 4 : WIND LOAD (NO ICE) SIDE)

	Member Label	Direction	Start Magnitude[lb/in.F.ksf]	End Magnitude[lb/in.F.ksf]	Start Location[in.%]	End Location[i...]
1	M1	PY	.74	.74	0	0
2	M2	PY	.74	.74	0	0



Company : Jacobs Telecommunications, Inc.
 Designer : H. Bedane
 Job Number : EP5TRFWL - Tulip Ave
 Model Name : Existing Wall Mount

May 6, 2022
 10:25 AM
 Checked By: B. Bartlett

Member Distributed Loads (BLC 4 : WIND LOAD (NO ICE) SIDE) (Continued)

	Member Label	Direction	Start Magnitude[lb/in,F,ksf]	End Magnitude[lb/in,F,ksf]	Start Location[in,%]	End Location[i...]
3	M3	PY	.74	.74	0	0
4	M4	PY	.74	.74	0	0
5	M5	PY	.74	.74	0	0
6	M6	PY	.74	.74	0	0
7	M7	PY	1.089	1.089	0	0
8	M8	PY	1.089	1.089	0	0
9	M9	PY	1.089	1.089	0	0

Member Distributed Loads (BLC 5 : WIND LOAD (ICE) FRONT)

	Member Label	Direction	Start Magnitude[lb/in,F,ksf]	End Magnitude[lb/in,F,ksf]	Start Location[in,%]	End Location[i...]
1	M1	PX	.173	.173	0	0
2	M2	PX	.173	.173	0	0
3	M3	PX	.173	.173	0	0
4	M4	PX	.173	.173	0	0
5	M5	PX	.173	.173	0	0
6	M6	PX	.173	.173	0	0
7	M7	PX	.213	.213	0	0
8	M8	PX	.213	.213	0	0
9	M9	PX	.213	.213	0	0

Member Distributed Loads (BLC 6 : WIND LOAD (ICE) SIDE)

	Member Label	Direction	Start Magnitude[lb/in,F,ksf]	End Magnitude[lb/in,F,ksf]	Start Location[in,%]	End Location[i...]
1	M1	PY	.173	.173	0	0
2	M2	PY	.173	.173	0	0
3	M3	PY	.173	.173	0	0
4	M4	PY	.173	.173	0	0
5	M5	PY	.173	.173	0	0
6	M6	PY	.173	.173	0	0
7	M7	PY	.213	.213	0	0
8	M8	PY	.213	.213	0	0
9	M9	PY	.213	.213	0	0

Member Distributed Loads (BLC 8 : WIND LOAD (SERVICE) FRONT)

	Member Label	Direction	Start Magnitude[lb/in,F,ksf]	End Magnitude[lb/in,F,ksf]	Start Location[in,%]	End Location[i...]
1	M1	PX	.052	.052	0	0
2	M2	PX	.052	.052	0	0
3	M3	PX	.052	.052	0	0
4	M4	PX	.052	.052	0	0
5	M5	PX	.052	.052	0	0
6	M6	PX	.052	.052	0	0
7	M7	PX	.077	.077	0	0
8	M8	PX	.077	.077	0	0
9	M9	PX	.077	.077	0	0

Member Distributed Loads (BLC 9 : WIND LOAD (SERVICE) SIDE)

	Member Label	Direction	Start Magnitude[lb/in,F,ksf]	End Magnitude[lb/in,F,ksf]	Start Location[in,%]	End Location[i...]
1	M1	PY	.052	.052	0	0
2	M2	PY	.052	.052	0	0
3	M3	PY	.052	.052	0	0
4	M4	PY	.052	.052	0	0
5	M5	PY	.052	.052	0	0
6	M6	PY	.052	.052	0	0
7	M7	PY	.077	.077	0	0
8	M8	PY	.077	.077	0	0
9	M9	PY	.077	.077	0	0



Company : Jacobs Telecommunications, Inc.
 Designer : H. Bedane
 Job Number : EP5TRFWL - Tulip Ave
 Model Name : Existing Wall Mount

May 6, 2022
 10:25 AM
 Checked By: B. Bartlett

Envelope Joint Reactions

	Joint		X [lb]	LC	Y [lb]	LC	Z [lb]	LC	MX [k-ft]	LC	MY [k-ft]	LC	MZ [k-ft]	LC
1	N149	max	396.668	3	355.745	5	1600.949	5	0	50	0	50	0	50
2		min	-338.301	9	-340.325	11	-1220.804	11	0	1	0	1	0	1
3	N146	max	396.662	13	340.325	5	1600.945	11	0	50	0	50	0	50
4		min	-338.296	7	-355.745	11	-1220.802	5	0	1	0	1	0	1
5	N34	max	755.799	7	633.461	12	112.693	7	0	50	0	50	0	50
6		min	-813.776	13	-602.972	6	-126.777	13	0	1	0	1	0	1
7	N35	max	755.843	9	602.961	10	112.705	9	0	50	0	50	0	50
8		min	-813.825	3	-633.45	4	-126.79	3	0	1	0	1	0	1
9	N152	max	387.825	13	318.278	5	1419.051	11	0	50	0	50	0	50
10		min	-362.287	7	-327.328	11	-1202.187	5	0	1	0	1	0	1
11	N155	max	387.83	3	327.328	5	1419.055	5	0	50	0	50	0	50
12		min	-362.292	9	-318.278	11	-1202.189	11	0	1	0	1	0	1
13	N45	max	772.248	7	599.065	12	116.404	7	0	50	0	50	0	50
14		min	-797.404	13	-584.896	6	-125.223	13	0	1	0	1	0	1
15	N46	max	772.295	9	584.886	10	116.416	9	0	50	0	50	0	50
16		min	-797.453	3	-599.055	4	-125.236	3	0	1	0	1	0	1
17	N158	max	387.803	13	318.283	5	1419.073	11	0	50	0	50	0	50
18		min	-362.266	7	-327.333	11	-1202.209	5	0	1	0	1	0	1
19	N161	max	387.809	3	327.333	5	1419.076	5	0	50	0	50	0	50
20		min	-362.272	9	-318.283	11	-1202.211	11	0	1	0	1	0	1
21	N56	max	772.219	7	599.061	12	116.398	7	0	50	0	50	0	50
22		min	-797.373	13	-584.893	6	-125.217	13	0	1	0	1	0	1
23	N57	max	772.266	9	584.883	10	116.411	9	0	50	0	50	0	50
24		min	-797.422	3	-599.051	4	-125.23	3	0	1	0	1	0	1
25	N164	max	169.996	13	130.101	5	750.289	12	0	50	0	50	0	50
26		min	-158.068	7	-142.497	11	-471.462	6	0	1	0	1	0	1
27	N167	max	169.996	3	142.497	5	750.288	4	0	50	0	50	0	50
28		min	-158.068	9	-130.101	11	-471.461	10	0	1	0	1	0	1
29	N67	max	405.76	7	347.233	12	217.743	7	0	50	0	50	0	50
30		min	-417.455	13	-344.837	6	-211.104	13	0	1	0	1	0	1
31	N68	max	405.784	9	344.832	10	217.765	9	0	50	0	50	0	50
32		min	-417.481	3	-347.229	4	-211.125	3	0	1	0	1	0	1
33	N170	max	170.52	13	121.626	5	636.423	12	0	50	0	50	0	50
34		min	-165.656	7	-127.479	11	-508.699	6	0	1	0	1	0	1
35	N173	max	170.521	3	127.48	5	636.423	4	0	50	0	50	0	50
36		min	-165.656	9	-121.626	11	-508.698	10	0	1	0	1	0	1
37	N78	max	413.895	7	331.91	12	218.339	7	0	50	0	50	0	50
38		min	-418.537	13	-330.362	6	-218.182	13	0	1	0	1	0	1
39	N79	max	413.921	9	330.357	10	218.362	9	0	50	0	50	0	50
40		min	-418.564	3	-331.906	4	-218.204	3	0	1	0	1	0	1
41	N176	max	170.52	13	121.626	5	636.423	12	0	50	0	50	0	50
42		min	-165.656	7	-127.479	11	-508.699	6	0	1	0	1	0	1
43	N179	max	170.521	3	127.48	5	636.423	4	0	50	0	50	0	50
44		min	-165.656	9	-121.626	11	-508.698	10	0	1	0	1	0	1
45	N89	max	413.895	7	331.91	12	218.339	7	0	50	0	50	0	50
46		min	-418.537	13	-330.362	6	-218.182	13	0	1	0	1	0	1
47	N90	max	413.921	9	330.357	10	218.361	9	0	50	0	50	0	50
48		min	-418.564	3	-331.905	4	-218.204	3	0	1	0	1	0	1
49	Totals:	max	2880.506	8	1853.507	11	3605.141	27						
50		min	-2880.504	2	-1853.507	5	1355.135	8						



Company : Jacobs Telecommunications, Inc.
 Designer : H. Bedane
 Job Number : EP5TRFWL - Tulip Ave
 Model Name : Existing Wall Mount

May 6, 2022
 10:25 AM
 Checked By: B. Bartlett

Envelope Member Section Forces

Member	Sec		Axial[lb]	LC	y Shear[lb]	LC	z Shear[lb]	LC	Torque...	LC	y-y Moment[k-...	LC	z-z Mo...	LC	
1	M1	1	max	375	38	.715	11	.853	8	0	50	0	50	50	
2			min	0	1	-.715	5	-1.573	27	0	1	0	1	1	
3		2	max	1030.492	2	21.706	11	27.236	8	.009	11	.02	2	.039	5
4			min	-786.118	8	-21.706	5	-27.312	2	-.009	5	-.022	8	-.039	11
5		3	max	0	50	.025	5	.044	2	0	50	0	50	0	50
6			min	0	1	-.025	11	-.038	8	0	1	0	1	0	1
7	M2	1	max	375	38	.274	36	.075	8	0	50	0	50	0	50
8			min	0	1	-.274	30	-1.132	27	0	1	0	1	0	1
9		2	max	799.001	2	36.141	11	62.066	8	.01	11	.169	2	.042	11
10			min	-663.508	8	-36.141	5	-62.078	2	-.01	5	-.169	8	-.042	5
11		3	max	0	50	.023	5	.044	2	0	50	0	50	0	50
12			min	0	1	-.023	11	-.041	8	0	1	0	1	0	1
13	M3	1	max	375	38	.274	36	.075	8	0	50	0	50	0	50
14			min	0	1	-.274	30	-1.132	27	0	1	0	1	0	1
15		2	max	798.916	2	36.142	11	62.062	8	.01	11	.169	2	.042	11
16			min	-663.427	8	-36.142	5	-62.073	2	-.01	5	-.169	8	-.042	5
17		3	max	0	50	.023	5	.044	2	0	50	0	50	0	50
18			min	0	1	-.023	11	-.041	8	0	1	0	1	0	1
19	M4	1	max	375	38	1.926	11	3.344	8	0	50	0	50	0	50
20			min	0	1	-1.926	5	-3.306	2	0	1	0	1	0	1
21		2	max	514.877	38	135.838	11	210.456	8	0	50	.562	8	.359	5
22			min	139.877	2	-135.838	5	-210.418	2	0	1	-.561	2	-.359	11
23		3	max	0	50	0	11	.004	8	0	50	0	50	0	50
24			min	0	1	0	5	-.003	2	0	1	0	1	0	1
25	M5	1	max	375	38	.646	11	1.258	8	0	50	0	50	0	50
26			min	0	1	-.646	5	-1.25	2	0	1	0	1	0	1
27		2	max	476.465	38	201.258	11	385.37	8	0	50	.457	8	.27	5
28			min	101.465	2	-201.258	5	-385.362	2	0	1	-.457	2	-.27	11
29		3	max	0	50	0	11	.004	8	0	50	0	50	0	50
30			min	0	1	0	5	-.004	2	0	1	0	1	0	1
31	M6	1	max	375	38	.646	11	1.258	8	0	50	0	50	0	50
32			min	0	1	-.646	5	-1.25	2	0	1	0	1	0	1
33		2	max	476.465	38	201.258	11	385.37	8	0	50	.457	8	.27	5
34			min	101.465	2	-201.258	5	-385.362	2	0	1	-.457	2	-.27	11
35		3	max	0	50	0	11	.004	8	0	50	0	50	0	50
36			min	0	1	0	5	-.004	2	0	1	0	1	0	1
37	M7	1	max	0	50	.013	11	.016	8	0	50	0	50	0	50
38			min	0	1	-.013	5	-.018	2	0	1	0	1	0	1
39		2	max	688.687	27	316.796	11	464.332	8	.125	11	1.307	8	.972	5
40			min	313.686	8	-316.796	5	-464.707	2	-.125	5	-1.575	2	-.972	11
41		3	max	0	50	0	11	.004	8	0	50	0	50	0	50
42			min	0	1	0	5	-.004	2	0	1	0	1	0	1
43	M8	1	max	0	50	.012	11	.017	8	0	50	0	50	0	50
44			min	0	1	-.012	5	-.018	2	0	1	0	1	0	1
45		2	max	531.222	33	293.423	11	477.662	8	.114	11	1.45	8	.905	5
46			min	156.222	2	-293.423	5	-477.737	2	-.114	5	-1.558	2	-.905	11
47		3	max	0	50	0	11	.004	8	0	50	0	50	0	50
48			min	0	1	0	5	-.004	2	0	1	0	1	0	1
49	M9	1	max	0	50	.012	11	.017	8	0	50	0	50	0	50
50			min	0	1	-.012	5	-.018	2	0	1	0	1	0	1
51		2	max	531.222	33	293.426	11	477.637	8	.114	11	1.45	8	.905	5
52			min	156.222	2	-293.426	5	-477.711	2	-.114	5	-1.558	2	-.905	11
53		3	max	0	50	0	11	.004	8	0	50	0	50	0	50
54			min	0	1	0	5	-.004	2	0	1	0	1	0	1
55	M10	1	max	0	50	0	50	0	50	0	50	0	50	0	50
56			min	0	1	0	1	0	1	0	1	0	1	0	1
57		2	max	0	8	0	50	0	50	0	50	0	1	0	1



Company : Jacobs Telecommunications, Inc.
 Designer : H. Bedane
 Job Number : EP5TRFWL - Tulip Ave
 Model Name : Existing Wall Mount

May 6, 2022
 10:25 AM
 Checked By: B. Bartlett

Envelope Member Section Forces (Continued)

Member	Sec		Axial[lb]	LC	y Shear[lb]	LC	z Shear[lb]	LC	Torque...	LC	y-y Moment[k-...	LC	z-z Mo...	LC
58		min	0	1	0	1	0	1	0	1	0	2	0	2
59		3 max	0	50	0	50	0	50	0	50	0	50	0	50
60		min	0	1	0	1	0	1	0	1	0	1	0	1
61	M11	1 max	0	50	0	50	0	50	0	50	0	50	0	50
62		min	0	1	0	1	0	1	0	1	0	1	0	1
63		2 max	-10.044	2	80.282	5	109.832	11	0	11	0	2	.003	8
64		min	-57.725	33	-80.282	11	-109.833	5	0	5	-.002	8	-.005	2
65		3 max	0	50	0	50	0	50	0	50	0	50	0	50
66		min	0	1	0	1	0	1	0	1	0	1	0	1
67	M12	1 max	0	50	0	50	0	50	0	50	0	50	0	50
68		min	0	1	0	1	0	1	0	1	0	1	0	1
69		2 max	0	2	0	1	0	5	0	50	0	50	0	1
70		min	0	8	0	4	0	11	0	1	0	1	0	2
71		3 max	0	50	0	50	0	50	0	50	0	50	0	50
72		min	0	1	0	1	0	1	0	1	0	1	0	1
73	M13	1 max	755.843	9	633.176	4	115.55	9	0	50	.089	10	.131	4
74		min	-813.825	3	-603.217	10	-123.599	3	0	1	-.093	4	-.125	10
75		2 max	755.843	9	633.176	4	116.107	9	0	50	.044	10	.066	4
76		min	-813.825	3	-603.217	10	-123.042	3	0	1	-.046	4	-.062	10
77		3 max	755.843	9	633.176	4	116.663	9	0	50	0	50	0	50
78		min	-813.825	3	-603.217	10	-122.486	3	0	1	0	1	0	1
79	M14	1 max	755.799	7	115.538	7	633.187	12	0	50	.089	6	.125	6
80		min	-813.776	13	-123.586	13	-603.227	6	0	1	-.093	12	-.131	12
81		2 max	755.799	7	116.094	7	633.187	12	0	50	.044	6	.062	6
82		min	-813.776	13	-123.029	13	-603.227	6	0	1	-.046	12	-.066	12
83		3 max	755.799	7	116.651	7	633.187	12	0	50	0	50	0	50
84		min	-813.776	13	-122.473	13	-603.227	6	0	1	0	1	0	1
85	M15	1 max	0	50	0	50	0	50	0	50	0	50	0	50
86		min	0	1	0	1	0	1	0	1	0	1	0	1
87		2 max	0	8	0	50	0	50	0	50	0	1	0	1
88		min	0	2	0	1	0	1	0	1	0	2	0	2
89		3 max	0	50	0	50	0	50	0	50	0	50	0	50
90		min	0	1	0	1	0	1	0	1	0	1	0	1
91	M16	1 max	0	50	0	50	0	50	0	50	0	50	0	50
92		min	0	1	0	1	0	1	0	1	0	1	0	1
93		2 max	2.575	2	74.5	5	101.951	11	0	11	.001	2	.004	8
94		min	-45.921	33	-74.5	11	-101.951	5	0	5	-.002	8	-.004	2
95		3 max	0	50	0	50	0	50	0	50	0	50	0	50
96		min	0	1	0	1	0	1	0	1	0	1	0	1
97	M17	1 max	0	50	0	50	0	50	0	50	0	50	0	50
98		min	0	1	0	1	0	1	0	1	0	1	0	1
99		2 max	0	2	0	1	0	5	0	50	0	50	0	1
100		min	0	8	0	4	0	11	0	1	0	1	0	2
101		3 max	0	50	0	50	0	50	0	50	0	50	0	50
102		min	0	1	0	1	0	1	0	1	0	1	0	1
103	M18	1 max	772.295	9	598.812	4	119.336	9	0	50	.085	10	.124	4
104		min	-797.453	3	-585.122	10	-122.22	3	0	1	-.087	4	-.122	10
105		2 max	772.295	9	598.812	4	119.892	9	0	50	.043	10	.062	4
106		min	-797.453	3	-585.122	10	-121.664	3	0	1	-.044	4	-.061	10
107		3 max	772.295	9	598.812	4	120.449	9	0	50	0	50	0	50
108		min	-797.453	3	-585.122	10	-121.108	3	0	1	0	1	0	1
109	M19	1 max	772.248	7	119.323	7	598.822	12	0	50	.085	6	.122	6
110		min	-797.404	13	-122.207	13	-585.132	6	0	1	-.087	12	-.124	12
111		2 max	772.248	7	119.88	7	598.822	12	0	50	.043	6	.061	6
112		min	-797.404	13	-121.651	13	-585.132	6	0	1	-.044	12	-.062	12
113		3 max	772.248	7	120.436	7	598.822	12	0	50	0	50	0	50
114		min	-797.404	13	-121.095	13	-585.132	6	0	1	0	1	0	1



Envelope Member Section Forces (Continued)

Member	Sec		Axial[lb]	LC	y Shear[lb]	LC	z Shear[lb]	LC	Torque...	LC	y-y Moment[k-...	LC	z-z Mo...	LC
115	M20	1	max	0	50	0	50	0	50	0	50	0	50	50
116			min	0	1	0	1	0	1	0	1	0	1	1
117		2	max	0	8	0	50	0	50	0	50	0	1	1
118			min	0	2	0	1	0	1	0	1	0	2	2
119		3	max	0	50	0	50	0	50	0	50	0	50	50
120			min	0	1	0	1	0	1	0	1	0	1	1
121	M21	1	max	0	50	0	50	0	50	0	50	0	50	50
122			min	0	1	0	1	0	1	0	1	0	1	1
123		2	max	2.574	2	74.501	5	101.953	11	0	11	.001	2	.004
124			min	-45.921	33	-74.501	11	-101.953	5	0	5	-.002	8	-.004
125		3	max	0	50	0	50	0	50	0	50	0	50	50
126			min	0	1	0	1	0	1	0	1	0	1	1
127	M22	1	max	0	50	0	50	0	50	0	50	0	50	50
128			min	0	1	0	1	0	1	0	1	0	1	1
129		2	max	0	2	0	1	0	5	0	50	0	50	1
130			min	0	8	0	4	0	11	0	1	0	1	2
131		3	max	0	50	0	50	0	50	0	50	0	50	50
132			min	0	1	0	1	0	1	0	1	0	1	1
133	M23	1	max	772.266	9	598.808	4	119.33	9	0	50	.085	10	.124
134			min	-797.422	3	-585.119	10	-122.215	3	0	1	-.087	4	-.122
135		2	max	772.266	9	598.808	4	119.887	9	0	50	.043	10	.062
136			min	-797.422	3	-585.119	10	-121.658	3	0	1	-.044	4	-.061
137		3	max	772.266	9	598.808	4	120.443	9	0	50	0	50	50
138			min	-797.422	3	-585.119	10	-121.102	3	0	1	0	1	1
139	M24	1	max	772.219	7	119.318	7	598.818	12	0	50	.085	6	.122
140			min	-797.373	13	-122.202	13	-585.129	6	0	1	-.087	12	-.124
141		2	max	772.219	7	119.874	7	598.818	12	0	50	.043	6	.061
142			min	-797.373	13	-121.645	13	-585.129	6	0	1	-.044	12	-.062
143		3	max	772.219	7	120.43	7	598.818	12	0	50	0	50	50
144			min	-797.373	13	-121.089	13	-585.129	6	0	1	0	1	1
145	M25	1	max	0	50	0	50	0	50	0	50	0	50	50
146			min	0	1	0	1	0	1	0	1	0	1	1
147		2	max	0	50	0	50	0	50	0	50	0	1	1
148			min	0	1	0	1	0	1	0	1	0	2	2
149		3	max	0	50	0	50	0	50	0	50	0	50	50
150			min	0	1	0	1	0	1	0	1	0	1	1
151	M26	1	max	0	50	0	50	0	50	0	50	0	50	50
152			min	0	1	0	1	0	1	0	1	0	1	1
153		2	max	-7.029	8	40.029	5	47.429	11	0	11	0	2	.002
154			min	-52.837	27	-40.029	11	-47.429	5	0	5	0	33	-.003
155		3	max	0	50	0	50	0	50	0	50	0	50	50
156			min	0	1	0	1	0	1	0	1	0	1	1
157	M27	1	max	0	50	0	50	0	50	0	50	0	50	50
158			min	0	1	0	1	0	1	0	1	0	1	1
159		2	max	0	50	0	1	0	5	0	50	0	50	1
160			min	0	1	0	11	0	11	0	1	0	1	2
161		3	max	0	50	0	50	0	50	0	50	0	50	50
162			min	0	1	0	1	0	1	0	1	0	1	1
163	M28	1	max	405.784	9	347.17	4	220.587	9	0	50	.028	11	.095
164			min	-417.481	3	-344.89	10	-208.508	3	0	1	-.031	5	-.097
165		2	max	405.784	9	347.17	4	221.144	9	0	50	.014	11	.048
166			min	-417.481	3	-344.89	10	-207.952	3	0	1	-.015	5	-.049
167		3	max	405.784	9	347.17	4	221.7	9	0	50	0	50	50
168			min	-417.481	3	-344.89	10	-207.395	3	0	1	0	1	1
169	M29	1	max	405.76	7	220.565	7	347.174	12	0	50	.028	5	.097
170			min	-417.455	13	-208.487	13	-344.894	6	0	1	-.031	11	-.095
171		2	max	405.76	7	221.122	7	347.174	12	0	50	.014	5	.049



Envelope Member Section Forces (Continued)

Member	Sec		Axial[lb]	LC	y Shear[lb]	LC	z Shear[lb]	LC	Torque...	LC	y-y Moment[k...	LC	z-z Mo...	LC
172		min	-417.455	13	-207.931	13	-344.894	6	0	1	-.015	11	-.048	13
173		max	405.76	7	221.678	7	347.174	12	0	50	0	50	0	50
174		min	-417.455	13	-207.375	13	-344.894	6	0	1	0	1	0	1
175	M30	max	0	50	0	50	0	50	0	50	0	50	0	50
176		min	0	1	0	1	0	1	0	1	0	1	0	1
177		max	0	50	0	50	0	50	0	50	0	1	0	1
178		min	0	1	0	1	0	1	0	1	0	2	0	2
179		max	0	50	0	50	0	50	0	50	0	50	0	50
180		min	0	1	0	1	0	1	0	1	0	1	0	1
181	M31	max	0	50	0	50	0	50	0	50	0	50	0	50
182		min	0	1	0	1	0	1	0	1	0	1	0	1
183		max	5.909	8	36.623	5	43.412	11	0	11	0	2	.002	8
184		min	-40.673	27	-36.623	11	-43.412	5	0	5	0	33	-.002	2
185		max	0	50	0	50	0	50	0	50	0	50	0	50
186		min	0	1	0	1	0	1	0	1	0	1	0	1
187	M32	max	0	50	0	50	0	50	0	50	0	50	0	50
188		min	0	1	0	1	0	1	0	1	0	1	0	1
189		max	0	50	0	1	0	5	0	50	0	50	0	1
190		min	0	1	0	11	0	11	0	1	0	1	0	2
191		max	0	50	0	50	0	50	0	50	0	50	0	50
192		min	0	1	0	1	0	1	0	1	0	1	0	1
193	M33	max	413.921	9	331.854	4	221.156	9	0	50	.026	11	.096	3
194		min	-418.564	3	-330.409	10	-215.528	3	0	1	-.028	5	-.097	9
195		max	413.921	9	331.854	4	221.713	9	0	50	.013	11	.048	3
196		min	-418.564	3	-330.409	10	-214.972	3	0	1	-.014	5	-.048	9
197		max	413.921	9	331.854	4	222.269	9	0	50	0	50	0	50
198		min	-418.564	3	-330.409	10	-214.416	3	0	1	0	1	0	1
199	M34	max	413.895	7	221.134	7	331.858	12	0	50	.026	5	.097	7
200		min	-418.537	13	-215.506	13	-330.413	6	0	1	-.028	11	-.096	13
201		max	413.895	7	221.69	7	331.858	12	0	50	.013	5	.048	7
202		min	-418.537	13	-214.95	13	-330.413	6	0	1	-.014	11	-.048	13
203		max	413.895	7	222.247	7	331.858	12	0	50	0	50	0	50
204		min	-418.537	13	-214.394	13	-330.413	6	0	1	0	1	0	1
205	M35	max	0	50	0	50	0	50	0	50	0	50	0	50
206		min	0	1	0	1	0	1	0	1	0	1	0	1
207		max	0	50	0	50	0	50	0	50	0	1	0	1
208		min	0	1	0	1	0	1	0	1	0	2	0	2
209		max	0	50	0	50	0	50	0	50	0	50	0	50
210		min	0	1	0	1	0	1	0	1	0	1	0	1
211	M36	max	0	50	0	50	0	50	0	50	0	50	0	50
212		min	0	1	0	1	0	1	0	1	0	1	0	1
213		max	5.91	8	36.623	5	43.412	11	0	11	0	2	.002	8
214		min	-40.673	27	-36.623	11	-43.412	5	0	5	0	33	-.002	2
215		max	0	50	0	50	0	50	0	50	0	50	0	50
216		min	0	1	0	1	0	1	0	1	0	1	0	1
217	M37	max	0	50	0	50	0	50	0	50	0	50	0	50
218		min	0	1	0	1	0	1	0	1	0	1	0	1
219		max	0	50	0	1	0	5	0	50	0	50	0	1
220		min	0	1	0	11	0	11	0	1	0	1	0	2
221		max	0	50	0	50	0	50	0	50	0	50	0	50
222		min	0	1	0	1	0	1	0	1	0	1	0	1
223	M38	max	413.921	9	331.854	4	221.156	9	0	50	.026	11	.096	3
224		min	-418.564	3	-330.409	10	-215.528	3	0	1	-.028	5	-.097	9
225		max	413.921	9	331.854	4	221.713	9	0	50	.013	11	.048	3
226		min	-418.564	3	-330.409	10	-214.972	3	0	1	-.014	5	-.048	9
227		max	413.921	9	331.854	4	222.269	9	0	50	0	50	0	50
228		min	-418.564	3	-330.409	10	-214.416	3	0	1	0	1	0	1



Envelope Member Section Forces (Continued)

Member	Sec		Axial[lb]	LC	y Shear[lb]	LC	z Shear[lb]	LC	Torque...	LC	y-y Moment[k-...	LC	z-z Mo...	LC	
229	M39	1	max	413.895	7	221.134	7	331.858	12	0	50	.026	5	.097	7
230			min	-418.537	13	-215.506	13	-330.413	6	0	1	-.028	11	-.096	13
231		2	max	413.895	7	221.69	7	331.858	12	0	50	.013	5	.048	7
232			min	-418.537	13	-214.95	13	-330.413	6	0	1	-.014	11	-.048	13
233		3	max	413.895	7	222.247	7	331.858	12	0	50	0	50	0	50
234			min	-418.537	13	-214.394	13	-330.413	6	0	1	0	1	0	1
235	M40	1	max	384.287	5	1488.485	5	380.99	2	.182	5	.032	13	.084	11
236			min	-311.784	11	-1113.599	11	-322.233	8	-.143	11	-.037	7	-.101	5
237		2	max	384.287	5	1488.485	5	380.99	2	.182	5	.09	2	-.012	8
238			min	12.835	2	-1488.482	11	-355.428	13	-.182	11	-.085	8	-.349	5
239		3	max	384.286	11	1113.597	5	322.229	8	.143	5	.032	3	.084	5
240			min	-311.783	5	-1488.482	11	-380.987	2	-.182	11	-.037	9	-.101	11
241	M41	1	max	380.987	2	1113.567	5	384.294	11	.101	11	.032	3	.143	5
242			min	-322.229	8	-1488.515	11	-311.782	5	-.084	5	-.037	9	-.182	11
243		2	max	380.987	2	1113.567	5	384.294	11	.101	11	.027	2	.081	4
244			min	-322.229	8	-1488.515	11	-311.782	5	-.084	5	-.027	8	-.097	10
245		3	max	380.987	2	1113.567	5	384.294	11	.101	11	.036	13	.048	2
246			min	-322.229	8	-1488.515	11	-311.782	5	-.084	5	-.032	7	-.04	8
247	M42	1	max	380.991	2	1113.569	11	311.782	11	.084	11	.037	7	.143	11
248			min	-322.233	8	-1488.518	5	-384.294	5	-.101	5	-.032	13	-.182	5
249		2	max	380.991	2	1113.569	11	311.782	11	.084	11	.027	8	.081	12
250			min	-322.233	8	-1488.518	5	-384.294	5	-.101	5	-.027	2	-.097	6
251		3	max	380.991	2	1113.569	11	311.782	11	.084	11	.032	9	.048	2
252			min	-322.233	8	-1488.518	5	-384.294	5	-.101	5	-.036	3	-.04	8
253	M43	1	max	1489.63	11	311.701	5	382.148	2	.023	6	.04	8	.039	11
254			min	-1112.454	5	-384.391	11	-322.543	8	-.026	12	-.048	2	-.038	5
255		2	max	1489.63	11	311.701	5	382.148	2	.023	6	.02	8	.063	11
256			min	-1112.454	5	-384.391	11	-322.543	8	-.026	12	-.024	2	-.057	5
257		3	max	1489.63	11	311.701	5	382.148	2	.023	6	.005	11	.087	11
258			min	-1112.454	5	-384.391	11	-322.543	8	-.026	12	-.005	5	-.077	5
259	M44	1	max	1489.634	5	384.392	5	382.15	2	.026	4	.04	8	.038	11
260			min	-1112.457	11	-311.702	11	-322.545	8	-.023	10	-.048	2	-.039	5
261		2	max	1489.634	5	384.392	5	382.15	2	.026	4	.02	8	.057	11
262			min	-1112.457	11	-311.702	11	-322.545	8	-.023	10	-.024	2	-.063	5
263		3	max	1489.634	5	384.392	5	382.15	2	.026	4	.005	5	.077	11
264			min	-1112.457	11	-311.702	11	-322.545	8	-.023	10	-.005	11	-.087	5
265	M45	1	max	602.961	10	108.169	9	755.828	9	.042	9	.091	7	.043	3
266			min	-633.451	4	-131.359	3	-813.841	3	-.048	3	-.1	13	-.037	9
267		2	max	602.972	6	131.346	13	813.792	13	.048	13	.184	8	.065	3
268			min	-633.461	12	-131.359	3	-813.841	3	-.048	3	-.202	2	-.055	9
269		3	max	602.972	6	131.346	13	813.792	13	.048	13	.091	9	.043	13
270			min	-633.461	12	-108.157	7	-755.784	7	-.042	7	-.1	3	-.037	7
271	M46	1	max	755.799	7	134.27	13	603.007	6	.037	7	.091	9	.048	13
272			min	-813.776	13	-105.833	7	-633.422	12	-.043	13	-.1	3	-.042	7
273		2	max	755.799	7	134.27	13	603.007	6	.037	7	.105	8	.039	13
274			min	-813.776	13	-105.833	7	-633.422	12	-.043	13	-.115	2	-.036	7
275		3	max	755.799	7	134.27	13	603.007	6	.037	7	.123	8	.031	13
276			min	-813.776	13	-105.833	7	-633.422	12	-.043	13	-.135	2	-.029	7
277	M47	1	max	755.843	9	134.282	3	633.411	4	.043	3	.1	13	.048	3
278			min	-813.825	3	-105.845	9	-602.997	10	-.037	9	-.091	7	-.042	9
279		2	max	755.843	9	134.282	3	633.411	4	.043	3	.115	2	.039	3
280			min	-813.825	3	-105.845	9	-602.997	10	-.037	9	-.105	8	-.036	9
281		3	max	755.843	9	134.282	3	633.411	4	.043	3	.135	2	.031	3
282			min	-813.825	3	-105.845	9	-602.997	10	-.037	9	-.123	8	-.029	9
283	M48	1	max	161.316	8	919.741	8	105.184	5	.033	5	.043	11	.343	8
284			min	-187.531	2	-897.567	2	-105.185	11	-.033	11	-.043	5	-.334	2
285		2	max	161.316	8	919.741	8	105.184	5	.033	5	.017	11	.113	8



Envelope Member Section Forces (Continued)

Member	Sec		Axial[lb]	LC	y Shear[lb]	LC	z Shear[lb]	LC	Torque...	LC	y-y Moment[k-...	LC	z-z Mo...	LC
286		min	-187.531	2	-897.567	2	-105.185	11	-.033	11	-.017	5	-.109	2
287		max	161.316	8	919.741	8	105.184	5	.033	5	.009	5	.115	2
288		min	-187.531	2	-897.567	2	-105.185	11	-.033	11	-.009	11	-.117	8
289	M49	max	234.818	8	1163.198	2	144.472	5	.176	5	.082	11	.766	2
290		min	-208.58	2	-653.338	8	-144.472	11	-.176	11	-.082	5	-.508	8
291		max	234.818	8	1163.198	2	144.472	5	.176	5	.046	11	.475	2
292		min	-208.58	2	-653.338	8	-144.472	11	-.176	11	-.046	5	-.345	8
293		max	234.818	8	1163.198	2	144.472	5	.176	5	.009	11	.184	2
294		min	-208.58	2	-653.338	8	-144.472	11	-.176	11	-.009	5	-.182	8
295	M50	max	211.273	8	736.013	8	113.783	5	.051	11	.047	11	.447	8
296		min	-233.124	2	-726.978	2	-113.78	11	-.051	5	-.047	5	-.443	2
297		max	211.273	8	736.013	8	113.783	5	.051	11	.018	11	.263	8
298		min	-233.124	2	-726.978	2	-113.78	11	-.051	5	-.018	5	-.262	2
299		max	211.273	8	736.013	8	113.783	5	.051	11	.01	5	.079	8
300		min	-233.124	2	-726.978	2	-113.78	11	-.051	5	-.01	11	-.08	2
301	M51	max	199.509	8	834.949	2	113.477	5	.176	5	.067	11	.657	2
302		min	-177.62	2	-627.723	8	-113.476	11	-.176	11	-.067	5	-.553	8
303		max	199.509	8	834.949	2	113.477	5	.176	5	.039	11	.448	2
304		min	-177.62	2	-627.723	8	-113.476	11	-.176	11	-.039	5	-.396	8
305		max	199.509	8	834.949	2	113.477	5	.176	5	.01	11	.24	2
306		min	-177.62	2	-627.723	8	-113.476	11	-.176	11	-.01	5	-.239	8
307	M52	max	211.273	8	735.932	8	113.781	5	.051	11	.047	11	.447	8
308		min	-233.154	2	-726.894	2	-113.779	11	-.051	5	-.047	5	-.443	2
309		max	211.273	8	735.932	8	113.781	5	.051	11	.018	11	.263	8
310		min	-233.154	2	-726.894	2	-113.779	11	-.051	5	-.018	5	-.262	2
311		max	211.273	8	735.932	8	113.781	5	.051	11	.01	5	.079	8
312		min	-233.154	2	-726.894	2	-113.779	11	-.051	5	-.01	11	-.08	2
313	M53	max	199.486	8	834.864	2	113.478	5	.176	5	.067	11	.657	2
314		min	-177.628	2	-627.642	8	-113.477	11	-.176	11	-.067	5	-.553	8
315		max	199.486	8	834.864	2	113.478	5	.176	5	.039	11	.448	2
316		min	-177.628	2	-627.642	8	-113.477	11	-.176	11	-.039	5	-.396	8
317		max	199.486	8	834.864	2	113.478	5	.176	5	.01	11	.24	2
318		min	-177.628	2	-627.642	8	-113.477	11	-.176	11	-.01	5	-.239	8
319	M54	max	343.933	5	1314.478	5	378.461	2	.162	5	.033	13	.081	11
320		min	-301.674	11	-1102.862	11	-352.577	8	-.139	11	-.037	7	-.091	5
321		max	343.933	5	1314.478	5	378.461	2	.162	5	.091	2	.147	7
322		min	-3.155	2	-1314.475	11	-352.577	8	-.162	11	-.09	8	-.31	5
323		max	343.932	11	1102.86	5	352.574	8	.139	5	.033	3	.081	5
324		min	-301.673	5	-1314.475	11	-378.458	2	-.162	11	-.037	9	-.091	11
325	M55	max	378.458	2	1102.833	5	343.937	11	.091	11	.033	3	.139	5
326		min	-352.574	8	-1314.505	11	-301.671	5	-.081	5	-.037	9	-.162	11
327		max	378.458	2	1102.833	5	343.937	11	.091	11	.028	2	.08	4
328		min	-352.574	8	-1314.505	11	-301.671	5	-.081	5	-.029	8	-.09	10
329		max	378.458	2	1102.833	5	343.937	11	.091	11	.035	13	.047	2
330		min	-352.574	8	-1314.505	11	-301.671	5	-.081	5	-.033	7	-.044	8
331	M56	max	378.461	2	1102.835	11	301.671	11	.081	11	.037	7	.139	11
332		min	-352.577	8	-1314.508	5	-343.938	5	-.091	5	-.033	13	-.162	5
333		max	378.461	2	1102.835	11	301.671	11	.081	11	.029	8	.08	12
334		min	-352.577	8	-1314.508	5	-343.938	5	-.091	5	-.028	2	-.09	6
335		max	378.461	2	1102.835	11	301.671	11	.081	11	.033	9	.047	2
336		min	-352.577	8	-1314.508	5	-343.938	5	-.091	5	-.035	3	-.044	8
337	M57	max	1315.618	11	301.598	5	379.315	2	.023	6	.044	8	.036	11
338		min	-1101.721	5	-344.019	11	-352.579	8	-.024	12	-.047	2	-.035	5
339		max	1315.618	11	301.598	5	379.315	2	.023	6	.022	8	.057	11
340		min	-1101.721	5	-344.019	11	-352.579	8	-.024	12	-.024	2	-.054	5
341		max	1315.618	11	301.598	5	379.315	2	.023	6	.005	11	.079	11
342		min	-1101.721	5	-344.019	11	-352.579	8	-.024	12	-.005	5	-.073	5



Company : Jacobs Telecommunications, Inc.
 Designer : H. Bedane
 Job Number : EP5TRFWL - Tulip Ave
 Model Name : Existing Wall Mount

May 6, 2022
 10:25 AM
 Checked By: B. Bartlett

Envelope Member Section Forces (Continued)

Member	Sec		Axial[lb]	LC	y Shear[lb]	LC	z Shear[lb]	LC	Torque...	LC	y-y Moment[k-...	LC	z-z Mo...	LC	
343	M58	1	max	1315.621	5	344.02	5	379.319	2	.024	4	.044	8	.035	11
344			min	-1101.723	11	-301.599	11	-352.582	8	-.023	10	-.047	2	-.036	5
345		2	max	1315.621	5	344.02	5	379.319	2	.024	4	.022	8	.054	11
346			min	-1101.723	11	-301.599	11	-352.582	8	-.023	10	-.024	2	-.057	5
347		3	max	1315.621	5	344.02	5	379.319	2	.024	4	.005	5	.073	11
348			min	-1101.723	11	-301.599	11	-352.582	8	-.023	10	-.005	11	-.079	5
349	M59	1	max	584.886	10	111.926	9	772.282	9	.044	9	.096	7	.043	3
350			min	-599.055	4	-129.739	3	-797.467	3	-.047	3	-.099	13	-.038	9
351		2	max	584.896	6	129.726	13	797.418	13	.047	13	.196	8	.064	3
352			min	-599.065	12	-129.739	3	-797.467	3	-.047	3	-.204	2	-.056	9
353		3	max	584.896	6	129.726	13	797.418	13	.047	13	.096	9	.043	13
354			min	-599.065	12	-111.913	7	-772.235	7	-.044	7	-.099	3	-.038	7
355	M60	1	max	772.248	7	132.648	13	584.928	6	.038	7	.096	9	.047	13
356			min	-797.404	13	-109.234	7	-599.031	12	-.043	13	-.099	3	-.044	7
357		2	max	772.248	7	132.648	13	584.928	6	.038	7	.112	8	.039	13
358			min	-797.404	13	-109.234	7	-599.031	12	-.043	13	-.116	2	-.037	7
359		3	max	772.248	7	132.648	13	584.928	6	.038	7	.131	8	.03	13
360			min	-797.404	13	-109.234	7	-599.031	12	-.043	13	-.136	2	-.03	7
361	M61	1	max	772.296	9	132.661	3	599.021	4	.043	3	.099	13	.047	3
362			min	-797.453	3	-109.246	9	-584.919	10	-.038	9	-.096	7	-.044	9
363		2	max	772.296	9	132.661	3	599.021	4	.043	3	.116	2	.039	3
364			min	-797.453	3	-109.246	9	-584.919	10	-.038	9	-.112	8	-.037	9
365		3	max	772.296	9	132.661	3	599.021	4	.043	3	.136	2	.03	3
366			min	-797.453	3	-109.246	9	-584.919	10	-.038	9	-.131	8	-.03	9
367	M62	1	max	343.938	5	1314.497	5	378.435	2	.162	5	.033	13	.081	11
368			min	-301.679	11	-1102.882	11	-352.552	8	-.139	11	-.037	7	-.091	5
369		2	max	343.938	5	1314.497	5	349.502	3	.162	5	.091	2	.147	7
370			min	-3.153	2	-1314.494	11	-378.433	2	-.162	11	-.09	8	-.31	5
371		3	max	343.937	11	1102.88	5	352.55	8	.139	5	.033	3	.081	5
372			min	-301.679	5	-1314.494	11	-378.433	2	-.162	11	-.037	9	-.091	11
373	M63	1	max	378.432	2	1102.853	5	343.942	11	.091	11	.033	3	.139	5
374			min	-352.551	8	-1314.524	11	-301.676	5	-.081	5	-.037	9	-.162	11
375		2	max	378.432	2	1102.853	5	343.942	11	.091	11	.028	2	.08	4
376			min	-352.551	8	-1314.524	11	-301.676	5	-.081	5	-.029	8	-.09	10
377		3	max	378.432	2	1102.853	5	343.942	11	.091	11	.035	13	.047	2
378			min	-352.551	8	-1314.524	11	-301.676	5	-.081	5	-.033	7	-.044	8
379	M64	1	max	378.435	2	1102.855	11	301.676	11	.081	11	.037	7	.139	11
380			min	-352.552	8	-1314.527	5	-343.943	5	-.091	5	-.033	13	-.162	5
381		2	max	378.435	2	1102.855	11	301.676	11	.081	11	.029	8	.08	12
382			min	-352.552	8	-1314.527	5	-343.943	5	-.091	5	-.028	2	-.09	6
383		3	max	378.435	2	1102.855	11	301.676	11	.081	11	.033	9	.047	2
384			min	-352.552	8	-1314.527	5	-343.943	5	-.091	5	-.035	3	-.044	8
385	M65	1	max	1315.637	11	301.604	5	379.29	2	.023	6	.044	8	.036	11
386			min	-1101.741	5	-344.024	11	-352.554	8	-.024	12	-.047	2	-.035	5
387		2	max	1315.637	11	301.604	5	379.29	2	.023	6	.022	8	.057	11
388			min	-1101.741	5	-344.024	11	-352.554	8	-.024	12	-.024	2	-.054	5
389		3	max	1315.637	11	301.604	5	379.29	2	.023	6	.005	11	.079	11
390			min	-1101.741	5	-344.024	11	-352.554	8	-.024	12	-.005	5	-.073	5
391	M66	1	max	1315.64	5	344.025	5	379.293	2	.024	4	.044	8	.035	11
392			min	-1101.743	11	-301.604	11	-352.558	8	-.023	10	-.047	2	-.036	5
393		2	max	1315.64	5	344.025	5	379.293	2	.024	4	.022	8	.054	11
394			min	-1101.743	11	-301.604	11	-352.558	8	-.023	10	-.024	2	-.057	5
395		3	max	1315.64	5	344.025	5	379.293	2	.024	4	.005	5	.073	11
396			min	-1101.743	11	-301.604	11	-352.558	8	-.023	10	-.005	11	-.079	5
397	M67	1	max	584.883	10	111.92	9	772.253	9	.044	9	.096	7	.043	3
398			min	-599.051	4	-129.733	3	-797.437	3	-.047	3	-.099	13	-.038	9
399		2	max	584.893	6	129.72	13	797.387	13	.047	13	.196	8	.064	3



Company : Jacobs Telecommunications, Inc.
 Designer : H. Bedane
 Job Number : EP5TRFWL - Tulip Ave
 Model Name : Existing Wall Mount

May 6, 2022
 10:25 AM
 Checked By: B. Bartlett

Envelope Member Section Forces (Continued)

Member	Sec		Axial[lb]	LC	y Shear[lb]	LC	z Shear[lb]	LC	Torque...	LC	y-y Moment[k-...	LC	z-z Mo...	LC	
400		min	-599.061	12	-129.733	3	-797.437	3	-.047	3	-.204	2	-.056	9	
401		max	584.893	6	129.72	13	797.387	13	.047	13	.096	9	.043	13	
402		min	-599.061	12	-111.908	7	-772.206	7	-.044	7	-.099	3	-.038	7	
403	M68	1	max	772.219	7	132.641	13	584.925	6	.038	7	.096	9	.047	13
404		min	-797.373	13	-109.229	7	-599.027	12	-.043	13	-.099	3	-.044	7	
405		max	772.219	7	132.641	13	584.925	6	.038	7	.112	8	.039	13	
406		min	-797.373	13	-109.229	7	-599.027	12	-.043	13	-.116	2	-.037	7	
407		max	772.219	7	132.641	13	584.925	6	.038	7	.131	8	.03	13	
408		min	-797.373	13	-109.229	7	-599.027	12	-.043	13	-.136	2	-.03	7	
409	M69	1	max	772.266	9	132.654	3	599.017	4	.043	3	.099	13	.047	3
410		min	-797.423	3	-109.241	9	-584.916	10	-.038	9	-.096	7	-.044	9	
411		max	772.266	9	132.654	3	599.017	4	.043	3	.116	2	.039	3	
412		min	-797.423	3	-109.241	9	-584.916	10	-.038	9	-.112	8	-.037	9	
413		max	772.266	9	132.654	3	599.017	4	.043	3	.136	2	.03	3	
414		min	-797.423	3	-109.241	9	-584.916	10	-.038	9	-.131	8	-.03	9	
415	M70	1	max	165.313	5	706.581	4	158.955	2	.085	5	.007	13	.035	10
416		min	-107.286	11	-433.02	10	-146.6	8	-.052	11	-.013	7	-.047	5	
417		max	165.313	5	706.581	4	149.465	3	.085	5	.032	2	.074	7	
418		min	9.016	8	-706.581	12	-158.955	2	-.085	11	-.036	8	-.164	12	
419		max	165.312	11	433.022	6	146.6	8	.052	5	.007	3	.035	6	
420		min	-107.286	5	-706.581	12	-158.955	2	-.085	11	-.013	9	-.047	11	
421	M71	1	max	158.955	2	433.223	6	165.313	11	.047	11	.007	3	.052	5
422		min	-146.601	8	-706.416	12	-107.285	5	-.035	6	-.013	9	-.085	11	
423		max	158.955	2	433.223	6	165.313	11	.047	11	.009	13	.026	5	
424		min	-146.601	8	-706.416	12	-107.285	5	-.035	6	-.012	7	-.042	11	
425		max	158.955	2	433.223	6	165.313	11	.047	11	.016	12	.02	2	
426		min	-146.601	8	-706.416	12	-107.285	5	-.035	6	-.015	6	-.018	8	
427	M72	1	max	158.956	2	433.222	10	107.285	11	.035	10	.013	7	.052	11
428		min	-146.601	8	-706.416	4	-165.314	5	-.047	5	-.007	13	-.085	5	
429		max	158.956	2	433.222	10	107.285	11	.035	10	.012	9	.026	11	
430		min	-146.601	8	-706.416	4	-165.314	5	-.047	5	-.009	3	-.042	5	
431		max	158.956	2	433.222	10	107.285	11	.035	10	.015	10	.02	2	
432		min	-146.601	8	-706.416	4	-165.314	5	-.047	5	-.016	4	-.018	8	
433	M73	1	max	707.699	12	107.273	5	160.402	2	.012	6	.018	8	.018	11
434		min	-431.906	6	-165.332	11	-146.367	8	-.012	12	-.02	2	-.018	5	
435		max	707.699	12	107.273	5	160.402	2	.012	6	.009	8	.028	11	
436		min	-431.906	6	-165.332	11	-146.367	8	-.012	12	-.01	2	-.024	5	
437		max	707.699	12	107.273	5	160.402	2	.012	6	.003	11	.039	11	
438		min	-431.906	6	-165.332	11	-146.367	8	-.012	12	-.003	5	-.031	5	
439	M74	1	max	707.699	4	165.333	5	160.402	2	.012	4	.018	8	.018	11
440		min	-431.904	10	-107.273	11	-146.367	8	-.012	10	-.02	2	-.018	5	
441		max	707.699	4	165.333	5	160.402	2	.012	4	.009	8	.024	11	
442		min	-431.904	10	-107.273	11	-146.367	8	-.012	10	-.01	2	-.028	5	
443		max	707.699	4	165.333	5	160.402	2	.012	4	.003	5	.031	11	
444		min	-431.904	10	-107.273	11	-146.367	8	-.012	10	-.003	11	-.039	5	
445	M75	1	max	344.832	10	213.189	9	405.781	9	.082	9	.047	7	.071	3
446		min	-347.229	4	-215.696	3	-417.484	3	-.079	3	-.05	13	-.072	9	
447		max	344.837	6	215.677	13	417.458	13	.082	9	.093	8	.107	3	
448		min	-347.233	12	-215.696	3	-417.484	3	-.082	7	-.098	2	-.107	9	
449		max	344.837	6	215.677	13	417.458	13	.079	13	.047	9	.071	13	
450		min	-347.233	12	-213.167	7	-405.757	7	-.082	7	-.05	3	-.072	7	
451	M76	1	max	405.76	7	218.15	13	344.842	6	.072	7	.047	9	.079	13
452		min	-417.455	13	-210.675	7	-347.227	12	-.071	13	-.05	3	-.082	7	
453		max	405.76	7	218.15	13	344.842	6	.072	7	.05	9	.066	13	
454		min	-417.455	13	-210.675	7	-347.227	12	-.071	13	-.054	3	-.068	7	
455		max	405.76	7	218.15	13	344.842	6	.072	7	.062	8	.052	13	
456		min	-417.455	13	-210.675	7	-347.227	12	-.071	13	-.065	2	-.055	7	



Envelope Member Section Forces (Continued)

Member	Sec		Axial[lb]	LC	y Shear[lb]	LC	z Shear[lb]	LC	Torque...	LC	y-y Moment[k-...	LC	z-z Mo...	LC	
457	M77	1	max	405.784	9	218.169	3	347.223	4	.071	3	.05	13	.079	3
458			min	-417.481	3	-210.696	9	-344.838	10	-.072	9	-.047	7	-.082	9
459		2	max	405.784	9	218.169	3	347.223	4	.071	3	.054	13	.066	3
460			min	-417.481	3	-210.696	9	-344.838	10	-.072	9	-.05	7	-.068	9
461		3	max	405.784	9	218.169	3	347.223	4	.071	3	.065	2	.052	3
462			min	-417.481	3	-210.696	9	-344.838	10	-.072	9	-.062	8	-.055	9
463	M78	1	max	138.043	5	596.195	4	163.253	2	.07	5	.009	13	.035	10
464			min	-111.063	11	-473.736	10	-157.988	8	-.055	11	-.012	7	-.041	4
465		2	max	138.043	5	596.195	4	157.988	8	.07	5	.035	2	.114	6
466			min	-67.336	7	-596.195	12	-163.253	2	-.07	11	-.037	8	-.14	12
467		3	max	138.042	11	473.737	6	157.988	8	.055	5	.009	3	.035	6
468			min	-111.063	5	-596.195	12	-163.253	2	-.07	11	-.012	9	-.041	12
469	M79	1	max	163.254	2	473.945	6	138.044	11	.041	12	.009	3	.055	5
470			min	-157.988	8	-596.005	12	-111.062	5	-.035	6	-.012	9	-.07	11
471		2	max	163.254	2	473.945	6	138.044	11	.041	12	.01	13	.028	5
472			min	-157.988	8	-596.005	12	-111.062	5	-.035	6	-.011	7	-.035	11
473		3	max	163.254	2	473.945	6	138.044	11	.041	12	.016	13	.021	2
474			min	-157.988	8	-596.005	12	-111.062	5	-.035	6	-.015	7	-.02	8
475	M80	1	max	163.254	2	473.944	10	111.062	11	.035	10	.012	7	.055	11
476			min	-157.989	8	-596.005	4	-138.045	5	-.041	4	-.009	13	-.07	5
477		2	max	163.254	2	473.944	10	111.062	11	.035	10	.011	9	.028	11
478			min	-157.989	8	-596.005	4	-138.045	5	-.041	4	-.01	3	-.035	5
479		3	max	163.254	2	473.944	10	111.062	11	.035	10	.015	9	.021	2
480			min	-157.989	8	-596.005	4	-138.045	5	-.041	4	-.016	3	-.02	8
481	M81	1	max	597.312	12	111.05	5	164.506	2	.011	6	.02	8	.016	11
482			min	-472.621	6	-138.058	11	-157.325	8	-.011	12	-.021	2	-.016	5
483		2	max	597.312	12	111.05	5	164.506	2	.011	6	.01	8	.025	11
484			min	-472.621	6	-138.058	11	-157.325	8	-.011	12	-.01	2	-.023	5
485		3	max	597.312	12	111.05	5	164.506	2	.011	6	.003	11	.034	11
486			min	-472.621	6	-138.058	11	-157.325	8	-.011	12	-.003	5	-.03	5
487	M82	1	max	597.312	4	138.059	5	164.507	2	.011	4	.02	8	.016	11
488			min	-472.62	10	-111.051	11	-157.326	8	-.011	10	-.021	2	-.016	5
489		2	max	597.312	4	138.059	5	164.507	2	.011	4	.01	8	.023	11
490			min	-472.62	10	-111.051	11	-157.326	8	-.011	10	-.01	2	-.025	5
491		3	max	597.312	4	138.059	5	164.507	2	.011	4	.003	5	.03	11
492			min	-472.62	10	-111.051	11	-157.326	8	-.011	10	-.003	11	-.034	5
493	M83	1	max	330.357	10	213.846	9	413.918	9	.082	9	.048	7	.074	3
494			min	-331.905	4	-222.715	3	-418.567	3	-.082	3	-.048	13	-.072	9
495		2	max	330.362	6	222.693	13	418.54	13	.082	13	.099	8	.111	3
496			min	-331.91	12	-222.715	3	-418.567	3	-.082	3	-.1	2	-.107	9
497		3	max	330.362	6	222.693	13	418.54	13	.082	13	.048	9	.074	13
498			min	-331.91	12	-213.823	7	-413.892	7	-.082	7	-.048	3	-.072	7
499	M84	1	max	413.895	7	225.425	13	330.367	6	.072	7	.048	9	.082	13
500			min	-418.537	13	-211.077	7	-331.904	12	-.074	13	-.048	3	-.082	7
501		2	max	413.895	7	225.425	13	330.367	6	.072	7	.052	9	.068	13
502			min	-418.537	13	-211.077	7	-331.904	12	-.074	13	-.053	3	-.069	7
503		3	max	413.895	7	225.425	13	330.367	6	.072	7	.066	8	.054	13
504			min	-418.537	13	-211.077	7	-331.904	12	-.074	13	-.067	2	-.055	7
505	M85	1	max	413.921	9	225.446	3	331.9	4	.074	3	.048	13	.082	3
506			min	-418.564	3	-211.098	9	-330.362	10	-.072	9	-.048	7	-.082	9
507		2	max	413.921	9	225.446	3	331.9	4	.074	3	.053	13	.068	3
508			min	-418.564	3	-211.098	9	-330.362	10	-.072	9	-.052	7	-.069	9
509		3	max	413.921	9	225.446	3	331.9	4	.074	3	.067	2	.054	3
510			min	-418.564	3	-211.098	9	-330.362	10	-.072	9	-.066	8	-.055	9
511	M86	1	max	138.043	5	596.195	4	163.253	2	.07	5	.009	13	.035	10
512			min	-111.063	11	-473.736	10	-157.988	8	-.055	11	-.012	7	-.041	4
513		2	max	138.043	5	596.195	4	157.988	8	.07	5	.035	2	.114	6



Envelope Member Section Forces (Continued)

Member	Sec		Axial[lb]	LC	y Shear[lb]	LC	z Shear[lb]	LC	Torque...	LC	y-y Moment[k-...	LC	z-z Mo...	LC	
514		min	-67.336	7	-596.195	12	-163.253	2	-.07	11	-.037	8	-.14	12	
515	3	max	138.042	11	473.737	6	157.988	8	.055	5	.009	3	.035	6	
516		min	-111.063	5	-596.195	12	-163.253	2	-.07	11	-.012	9	-.041	12	
517	M87	1	max	163.253	2	473.945	6	138.044	11	.041	12	.009	3	.055	5
518		min	-157.988	8	-596.006	12	-111.062	5	-.035	6	-.012	9	-.07	11	
519		2	max	163.253	2	473.945	6	138.044	11	.041	12	.01	13	.028	5
520		min	-157.988	8	-596.006	12	-111.062	5	-.035	6	-.011	7	-.035	11	
521		3	max	163.253	2	473.945	6	138.044	11	.041	12	.016	13	.021	2
522		min	-157.988	8	-596.006	12	-111.062	5	-.035	6	-.015	7	-.02	8	
523	M88	1	max	163.253	2	473.944	10	111.062	11	.035	10	.012	7	.055	11
524		min	-157.988	8	-596.005	4	-138.044	5	-.041	4	-.009	13	-.07	5	
525		2	max	163.253	2	473.944	10	111.062	11	.035	10	.011	9	.028	11
526		min	-157.988	8	-596.005	4	-138.044	5	-.041	4	-.01	3	-.035	5	
527		3	max	163.253	2	473.944	10	111.062	11	.035	10	.015	9	.021	2
528		min	-157.988	8	-596.005	4	-138.044	5	-.041	4	-.016	3	-.02	8	
529	M89	1	max	597.312	12	111.05	5	164.506	2	.011	6	.02	8	.016	11
530		min	-472.621	6	-138.058	11	-157.325	8	-.011	12	-.021	2	-.016	5	
531		2	max	597.312	12	111.05	5	164.506	2	.011	6	.01	8	.025	11
532		min	-472.621	6	-138.058	11	-157.325	8	-.011	12	-.01	2	-.023	5	
533		3	max	597.312	12	111.05	5	164.506	2	.011	6	.003	11	.034	11
534		min	-472.621	6	-138.058	11	-157.325	8	-.011	12	-.003	5	-.03	5	
535	M90	1	max	597.312	4	138.059	5	164.507	2	.011	4	.02	8	.016	11
536		min	-472.62	10	-111.051	11	-157.325	8	-.011	10	-.021	2	-.016	5	
537		2	max	597.312	4	138.059	5	164.507	2	.011	4	.01	8	.023	11
538		min	-472.62	10	-111.051	11	-157.325	8	-.011	10	-.01	2	-.025	5	
539		3	max	597.312	4	138.059	5	164.507	2	.011	4	.003	5	.03	11
540		min	-472.62	10	-111.051	11	-157.325	8	-.011	10	-.003	11	-.034	5	
541	M91	1	max	330.357	10	213.846	9	413.918	9	.082	9	.048	7	.074	3
542		min	-331.905	4	-222.715	3	-418.567	3	-.082	3	-.048	13	-.072	9	
543		2	max	330.362	6	222.693	13	418.54	13	.082	13	.099	8	.111	3
544		min	-331.91	12	-222.715	3	-418.567	3	-.082	3	-.1	2	-.107	9	
545		3	max	330.362	6	222.693	13	418.54	13	.082	13	.048	9	.074	13
546		min	-331.91	12	-213.823	7	-413.892	7	-.082	7	-.048	3	-.072	7	
547	M92	1	max	413.895	7	225.425	13	330.367	6	.072	7	.048	9	.082	13
548		min	-418.537	13	-211.076	7	-331.904	12	-.074	13	-.048	3	-.082	7	
549		2	max	413.895	7	225.425	13	330.367	6	.072	7	.052	9	.068	13
550		min	-418.537	13	-211.076	7	-331.904	12	-.074	13	-.053	3	-.069	7	
551		3	max	413.895	7	225.425	13	330.367	6	.072	7	.066	8	.054	13
552		min	-418.537	13	-211.076	7	-331.904	12	-.074	13	-.067	2	-.055	7	
553	M93	1	max	413.921	9	225.446	3	331.9	4	.074	3	.048	13	.082	3
554		min	-418.564	3	-211.097	9	-330.362	10	-.072	9	-.048	7	-.082	9	
555		2	max	413.921	9	225.446	3	331.9	4	.074	3	.053	13	.068	3
556		min	-418.564	3	-211.097	9	-330.362	10	-.072	9	-.052	7	-.069	9	
557		3	max	413.921	9	225.446	3	331.9	4	.074	3	.067	2	.054	3
558		min	-418.564	3	-211.097	9	-330.362	10	-.072	9	-.066	8	-.055	9	

Envelope Member Section Stresses

Member	Sec		Axial[ksi]	LC	y Shear[ksi]	LC	z Shear[ksi]	LC	y-Top[ksi]	LC	y-Bot[...LC	z-Top[...LC	z-Bot[...LC				
1	M1	1	max	.368	38	.001	11	.002	8	0	50	0	50	0	50		
2			min	0	1	-.001	5	-.003	27	0	1	0	1	0	1		
3		2	max	1.01	2	.043	11	.053	8	.876	11	.876	5	.444	2	.493	8
4			min	-.771	8	-.043	5	-.054	2	-.876	5	-.876	11	-.493	8	-.444	2
5		3	max	0	50	0	5	0	2	0	50	0	50	0	50	0	50
6			min	0	1	0	11	0	8	0	1	0	1	0	1	0	1
7	M2	1	max	.368	38	0	36	0	8	0	50	0	50	0	50	0	50



Envelope Member Section Stresses (Continued)

Member	Sec		Axial[ksi]	LC	v Shear[ksi]	LC	z Shear[ksi]	LC	v-Top[ksi]	LC	v-Bot[ksi]	LC	z-Top[ksi]	LC	z-Bot[ksi]	LC
8		min	0	1	0	30	-.002	27	0	1	0	1	0	1	0	1
9	2	max	.783	2	.071	11	.122	8	.946	5	.946	11	3.83	2	3.849	8
10		min	-.65	8	-.071	5	-.122	2	-.946	11	-.946	5	-3.849	8	-3.83	2
11	3	max	0	50	0	5	0	2	0	50	0	50	0	50	0	50
12		min	0	1	0	11	0	8	0	1	0	1	0	1	0	1
13	M3	1	max	.368	38	0	36	0	0	50	0	50	0	50	0	50
14		min	0	1	0	30	-.002	27	0	1	0	1	0	1	0	1
15	2	max	.783	2	.071	11	.122	8	.946	5	.946	11	3.83	2	3.849	8
16		min	-.65	8	-.071	5	-.122	2	-.946	11	-.946	5	-3.849	8	-3.83	2
17	3	max	0	50	0	5	0	2	0	50	0	50	0	50	0	50
18		min	0	1	0	11	0	8	0	1	0	1	0	1	0	1
19	M4	1	max	.368	38	.004	11	.007	0	50	0	50	0	50	0	50
20		min	0	1	-.004	5	-.006	2	0	1	0	1	0	1	0	1
21	2	max	.505	38	.266	11	.413	8	8.167	11	8.167	5	12.764	8	12.76	2
22		min	.137	2	-.266	5	-.413	2	-8.167	5	-8.167	11	-12.76	2	-12.764	8
23	3	max	0	50	0	11	0	8	0	50	0	50	0	50	0	50
24		min	0	1	0	5	0	2	0	1	0	1	0	1	0	1
25	M5	1	max	.368	38	.001	11	.002	0	50	0	50	0	50	0	50
26		min	0	1	-.001	5	-.002	2	0	1	0	1	0	1	0	1
27	2	max	.467	38	.395	11	.756	8	6.147	11	6.147	5	10.387	8	10.386	2
28		min	.099	2	-.395	5	-.756	2	-6.147	5	-6.147	11	-10.386	2	-10.387	8
29	3	max	0	50	0	11	0	8	0	50	0	50	0	50	0	50
30		min	0	1	0	5	0	2	0	1	0	1	0	1	0	1
31	M6	1	max	.368	38	.001	11	.002	0	50	0	50	0	50	0	50
32		min	0	1	-.001	5	-.002	2	0	1	0	1	0	1	0	1
33	2	max	.467	38	.395	11	.756	8	6.147	11	6.147	5	10.387	8	10.386	2
34		min	.099	2	-.395	5	-.756	2	-6.147	5	-6.147	11	-10.386	2	-10.387	8
35	3	max	0	50	0	11	0	8	0	50	0	50	0	50	0	50
36		min	0	1	0	5	0	2	0	1	0	1	0	1	0	1
37	M7	1	max	0	50	0	11	0	0	50	0	50	0	50	0	50
38		min	0	1	0	5	0	2	0	1	0	1	0	1	0	1
39	2	max	.333	38	.306	11	.449	8	7.164	11	7.164	5	9.628	8	11.605	2
40		min	.152	7	-.306	5	-.449	2	-7.164	5	-7.164	11	-11.605	2	-9.628	8
41	3	max	0	50	0	11	0	8	0	50	0	50	0	50	0	50
42		min	0	1	0	5	0	2	0	1	0	1	0	1	0	1
43	M8	1	max	0	50	0	11	0	0	50	0	50	0	50	0	50
44		min	0	1	0	5	0	2	0	1	0	1	0	1	0	1
45	2	max	.257	38	.284	11	.462	8	6.672	11	6.672	5	10.684	8	11.483	2
46		min	.075	2	-.284	5	-.462	2	-6.672	5	-6.672	11	-11.483	2	-10.684	8
47	3	max	0	50	0	11	0	8	0	50	0	50	0	50	0	50
48		min	0	1	0	5	0	2	0	1	0	1	0	1	0	1
49	M9	1	max	0	50	0	11	0	0	50	0	50	0	50	0	50
50		min	0	1	0	5	0	2	0	1	0	1	0	1	0	1
51	2	max	.257	38	.284	11	.461	8	6.672	11	6.672	5	10.683	8	11.482	2
52		min	.075	2	-.284	5	-.462	2	-6.672	5	-6.672	11	-11.482	2	-10.683	8
53	3	max	0	50	0	11	0	8	0	50	0	50	0	50	0	50
54		min	0	1	0	5	0	2	0	1	0	1	0	1	0	1
55	M10	1	max	0	50	0	50	0	0	50	0	50	0	50	0	50
56		min	0	1	0	1	0	1	0	1	0	1	0	1	0	1
57	2	max	0	8	0	50	0	50	0	9	0	1	0	1	0	50
58		min	0	1	0	1	0	1	0	1	0	7	0	2	0	1
59	3	max	0	50	0	50	0	50	0	50	0	50	0	50	0	50
60		min	0	1	0	1	0	1	0	1	0	1	0	1	0	1
61	M11	1	max	0	50	0	50	0	0	50	0	50	0	50	0	50
62		min	0	1	0	1	0	1	0	1	0	1	0	1	0	1
63	2	max	-.009	2	.171	5	.234	11	.076	2	.048	8	.03	2	.066	8
64		min	-.053	33	-.171	11	-.234	5	-.048	8	-.076	2	-.06	8	-.033	2



Envelope Member Section Stresses (Continued)

Member	Sec		Axial[ksi]	LC	y Shear[ksi]	LC	z Shear[ksi]	LC	y-Top[ksi]	LC	y-Bot[...]	LC	z-Top[...]	LC	z-Bot[...]	LC
65	3	max	0	50	0	50	0	50	0	50	0	50	0	50	0	50
66		min	0	1	0	1	0	1	0	1	0	1	0	1	0	1
67	M12	1	max	0	50	0	50	0	50	0	50	0	50	0	50	0
68		min	0	1	0	1	0	1	0	1	0	1	0	1	0	1
69		2	max	0	13	0	1	0	50	0	9	0	1	0	13	0
70		min	0	7	0	2	0	1	0	1	0	7	0	1	0	2
71		3	max	0	50	0	50	0	50	0	50	0	50	0	50	0
72		min	0	1	0	1	0	1	0	1	0	1	0	1	0	1
73	M13	1	max	.693	9	1.347	4	.246	9	2.02	10	2.126	4	2.954	10	3.412
74		min	-.747	3	-1.283	10	-.263	3	-2.126	4	-2.02	10	-3.089	4	-3.263	10
75		2	max	.693	9	1.347	4	.247	9	1.01	10	1.062	4	1.476	10	1.707
76		min	-.747	3	-1.283	10	-.262	3	-1.062	4	-1.01	10	-1.545	4	-1.631	10
77		3	max	.693	9	1.347	4	.248	9	0	50	0	50	0	50	0
78		min	-.747	3	-1.283	10	-.261	3	0	1	0	1	0	1	0	1
79	M14	1	max	.693	7	.246	7	1.347	12	2.126	12	2.02	6	2.954	6	3.412
80		min	-.747	13	-.263	13	-1.283	6	-2.02	6	-2.126	12	-3.089	12	-3.263	6
81		2	max	.693	7	.247	7	1.347	12	1.062	12	1.01	6	1.476	6	1.707
82		min	-.747	13	-.262	13	-1.283	6	-1.01	6	-1.062	12	-1.545	12	-1.631	6
83		3	max	.693	7	.248	7	1.347	12	0	50	0	50	0	50	0
84		min	-.747	13	-.261	13	-1.283	6	0	1	0	1	0	1	0	1
85	M15	1	max	0	50	0	50	0	50	0	50	0	50	0	50	0
86		min	0	1	0	1	0	1	0	1	0	1	0	1	0	1
87		2	max	0	8	0	50	0	50	0	9	0	1	0	1	0
88		min	0	1	0	1	0	1	0	1	0	7	0	2	0	1
89		3	max	0	50	0	50	0	50	0	50	0	50	0	50	0
90		min	0	1	0	1	0	1	0	1	0	1	0	1	0	1
91	M16	1	max	0	50	0	50	0	50	0	50	0	50	0	50	0
92		min	0	1	0	1	0	1	0	1	0	1	0	1	0	1
93		2	max	.002	2	.159	5	.217	11	.072	2	.057	8	.037	2	.062
94		min	-.042	33	-.159	11	-.217	5	-.057	8	-.072	2	-.056	8	-.041	2
95		3	max	0	50	0	50	0	50	0	50	0	50	0	50	0
96		min	0	1	0	1	0	1	0	1	0	1	0	1	0	1
97	M17	1	max	0	50	0	50	0	50	0	50	0	50	0	50	0
98		min	0	1	0	1	0	1	0	1	0	1	0	1	0	1
99		2	max	0	13	0	1	0	50	0	9	0	1	0	13	0
100		min	0	7	0	2	0	1	0	1	0	7	0	1	0	2
101		3	max	0	50	0	50	0	50	0	50	0	50	0	50	0
102		min	0	1	0	1	0	1	0	1	0	1	0	1	0	1
103	M18	1	max	.709	9	1.274	4	.254	9	1.97	10	2.015	4	2.843	10	3.217
104		min	-.732	3	-1.245	10	-.26	3	-2.015	4	-1.97	10	-2.912	4	-3.141	10
105		2	max	.709	9	1.274	4	.255	9	.985	10	1.007	4	1.421	10	1.61
106		min	-.732	3	-1.245	10	-.259	3	-1.007	4	-.985	10	-1.457	4	-1.569	10
107		3	max	.709	9	1.274	4	.256	9	0	50	0	50	0	50	0
108		min	-.732	3	-1.245	10	-.258	3	0	1	0	1	0	1	0	1
109	M19	1	max	.708	7	.254	7	1.274	12	2.015	12	1.97	6	2.843	6	3.217
110		min	-.732	13	-.26	13	-1.245	6	-1.97	6	-2.015	12	-2.912	12	-3.141	6
111		2	max	.708	7	.255	7	1.274	12	1.007	12	.985	6	1.421	6	1.61
112		min	-.732	13	-.259	13	-1.245	6	-.985	6	-1.007	12	-1.457	12	-1.569	6
113		3	max	.708	7	.256	7	1.274	12	0	50	0	50	0	50	0
114		min	-.732	13	-.258	13	-1.245	6	0	1	0	1	0	1	0	1
115	M20	1	max	0	50	0	50	0	50	0	50	0	50	0	50	0
116		min	0	1	0	1	0	1	0	1	0	1	0	1	0	1
117		2	max	0	8	0	50	0	50	0	9	0	1	0	1	0
118		min	0	1	0	1	0	1	0	1	0	7	0	2	0	1
119		3	max	0	50	0	50	0	50	0	50	0	50	0	50	0
120		min	0	1	0	1	0	1	0	1	0	1	0	1	0	1
121	M21	1	max	0	50	0	50	0	50	0	50	0	50	0	50	0



Envelope Member Section Stresses (Continued)

Member	Sec		Axial[ksi]	LC	v Shear[ksi]	LC	z Shear[ksi]	LC	v-Top[ksi]	LC	v-Bot[ksi]	LC	z-Top[ksi]	LC	z-Bot[ksi]	LC	
122		min	0	1	0	1	0	1	0	1	0	1	0	1	0	1	
123	2	max	.002	2	.159	5	.217	11	.072	2	.057	8	.037	2	.062	8	
124		min	-.042	33	-.159	11	-.217	5	-.057	8	-.072	2	-.056	8	-.041	2	
125	3	max	0	50	0	50	0	50	0	50	0	50	0	50	0	50	
126		min	0	1	0	1	0	1	0	1	0	1	0	1	0	1	
127	M22	1	max	0	50	0	50	0	50	0	50	0	50	0	50	0	
128		min	0	1	0	1	0	1	0	1	0	1	0	1	0	1	
129	2	max	0	13	0	1	0	50	0	9	0	1	0	13	0	1	
130		min	0	7	0	2	0	1	0	1	0	7	0	1	0	2	
131	3	max	0	50	0	50	0	50	0	50	0	50	0	50	0	50	
132		min	0	1	0	1	0	1	0	1	0	1	0	1	0	1	
133	M23	1	max	.709	9	1.274	4	.254	9	1.97	10	2.015	4	2.843	10	3.217	4
134		min	-.732	3	-1.245	10	-.26	3	-2.015	4	-1.97	10	-2.912	4	-3.141	10	
135	2	max	.709	9	1.274	4	.255	9	.985	10	1.007	4	1.421	10	1.61	4	
136		min	-.732	3	-1.245	10	-.259	3	-1.007	4	-.985	10	-1.457	4	-1.569	10	
137	3	max	.709	9	1.274	4	.256	9	0	50	0	50	0	50	0	50	
138		min	-.732	3	-1.245	10	-.258	3	0	1	0	1	0	1	0	1	
139	M24	1	max	.708	7	.254	7	1.274	12	2.015	12	1.97	6	2.843	6	3.217	12
140		min	-.732	13	-.26	13	-1.245	6	-1.97	6	-2.015	12	-2.912	12	-3.141	6	
141	2	max	.708	7	.255	7	1.274	12	1.007	12	.985	6	1.421	6	1.61	12	
142		min	-.732	13	-.259	13	-1.245	6	-.985	6	-1.007	12	-1.457	12	-1.569	6	
143	3	max	.708	7	.256	7	1.274	12	0	50	0	50	0	50	0	50	
144		min	-.732	13	-.258	13	-1.245	6	0	1	0	1	0	1	0	1	
145	M25	1	max	0	50	0	50	0	50	0	50	0	50	0	50	0	50
146		min	0	1	0	1	0	1	0	1	0	1	0	1	0	1	
147	2	max	0	50	0	50	0	50	0	9	0	1	0	1	0	50	
148		min	0	1	0	1	0	1	0	1	0	7	0	2	0	1	
149	3	max	0	50	0	50	0	50	0	50	0	50	0	50	0	50	
150		min	0	1	0	1	0	1	0	1	0	1	0	1	0	1	
151	M26	1	max	0	50	0	50	0	50	0	50	0	50	0	50	0	50
152		min	0	1	0	1	0	1	0	1	0	1	0	1	0	1	
153	2	max	-.006	8	.085	5	.101	11	.042	2	.026	8	-.008	2	.033	33	
154		min	-.048	27	-.085	11	-.101	5	-.026	8	-.042	2	-.03	33	.009	2	
155	3	max	0	50	0	50	0	50	0	50	0	50	0	50	0	50	
156		min	0	1	0	1	0	1	0	1	0	1	0	1	0	1	
157	M27	1	max	0	50	0	50	0	50	0	50	0	50	0	50	0	50
158		min	0	1	0	1	0	1	0	1	0	1	0	1	0	1	
159	2	max	0	50	0	1	0	50	0	13	0	1	0	13	0	1	
160		min	0	1	0	2	0	1	0	1	0	2	0	1	0	2	
161	3	max	0	50	0	50	0	50	0	50	0	50	0	50	0	50	
162		min	0	1	0	1	0	1	0	1	0	1	0	1	0	1	
163	M28	1	max	.372	9	.739	4	.469	9	1.542	9	1.542	3	.934	11	1.133	5
164		min	-.383	3	-.734	10	-.444	3	-1.542	3	-1.542	9	-1.026	5	-1.031	11	
165	2	max	.372	9	.739	4	.471	9	.787	9	.771	3	.466	11	.568	5	
166		min	-.383	3	-.734	10	-.442	3	-.771	3	-.787	9	-.514	5	-.515	11	
167	3	max	.372	9	.739	4	.472	9	0	50	0	50	0	50	0	50	
168		min	-.383	3	-.734	10	-.441	3	0	1	0	1	0	1	0	1	
169	M29	1	max	.372	7	.469	7	.739	12	1.542	13	1.542	7	.934	5	1.134	11
170		min	-.383	13	-.444	13	-.734	6	-1.542	7	-1.542	13	-1.026	11	-1.031	5	
171	2	max	.372	7	.47	7	.739	12	.771	13	.787	7	.466	5	.568	11	
172		min	-.383	13	-.442	13	-.734	6	-.787	7	-.771	13	-.514	11	-.515	5	
173	3	max	.372	7	.472	7	.739	12	0	50	0	50	0	50	0	50	
174		min	-.383	13	-.441	13	-.734	6	0	1	0	1	0	1	0	1	
175	M30	1	max	0	50	0	50	0	50	0	50	0	50	0	50	0	50
176		min	0	1	0	1	0	1	0	1	0	1	0	1	0	1	
177	2	max	0	50	0	50	0	50	0	9	0	1	0	1	0	50	
178		min	0	1	0	1	0	1	0	1	0	7	0	2	0	1	



Envelope Member Section Stresses (Continued)

Member	Sec		Axial[ksi]	LC	y Shear[ksi]	LC	z Shear[ksi]	LC	y-Top[ksi]	LC	y-Bot[...]	LC	z-Top[...]	LC	z-Bot[...]	LC
179	3	max	0	50	0	50	0	50	0	50	0	50	0	50	0	50
180		min	0	1	0	1	0	1	0	1	0	1	0	1	0	1
181	M31	1	max	0	50	0	50	0	50	0	50	0	50	0	50	0
182		min	0	1	0	1	0	1	0	1	0	1	0	1	0	1
183		2	max	.005	8	.078	5	.092	11	.039	2	.032	8	0	2	.026
184		min	-.037	27	-.078	11	-.092	5	-.032	8	-.039	2	-.023	33	.001	2
185		3	max	0	50	0	50	0	50	0	50	0	50	0	50	0
186		min	0	1	0	1	0	1	0	1	0	1	0	1	0	1
187	M32	1	max	0	50	0	50	0	50	0	50	0	50	0	50	0
188		min	0	1	0	1	0	1	0	1	0	1	0	1	0	1
189		2	max	0	50	0	1	0	50	0	13	0	1	0	13	0
190		min	0	1	0	2	0	1	0	1	0	2	0	1	0	2
191		3	max	0	50	0	50	0	50	0	50	0	50	0	50	0
192		min	0	1	0	1	0	1	0	1	0	1	0	1	0	1
193	M33	1	max	.38	9	.706	4	.471	9	1.568	9	1.553	3	.87	11	1.015
194		min	-.384	3	-.703	10	-.459	3	-1.553	3	-1.568	9	-.919	5	-.961	11
195		2	max	.38	9	.706	4	.472	9	.785	9	.776	3	.434	11	.508
196		min	-.384	3	-.703	10	-.457	3	-.776	3	-.785	9	-.46	5	-.48	11
197		3	max	.38	9	.706	4	.473	9	0	50	0	50	0	50	0
198		min	-.384	3	-.703	10	-.456	3	0	1	0	1	0	1	0	1
199	M34	1	max	.38	7	.47	7	.706	12	1.553	13	1.568	7	.87	5	1.015
200		min	-.384	13	-.459	13	-.703	6	-1.568	7	-1.553	13	-.919	11	-.961	5
201		2	max	.38	7	.472	7	.706	12	.776	13	.785	7	.434	5	.508
202		min	-.384	13	-.457	13	-.703	6	-.785	7	-.776	13	-.46	11	-.48	5
203		3	max	.38	7	.473	7	.706	12	0	50	0	50	0	50	0
204		min	-.384	13	-.456	13	-.703	6	0	1	0	1	0	1	0	1
205	M35	1	max	0	50	0	50	0	50	0	50	0	50	0	50	0
206		min	0	1	0	1	0	1	0	1	0	1	0	1	0	1
207		2	max	0	50	0	50	0	50	0	9	0	1	0	1	0
208		min	0	1	0	1	0	1	0	1	0	7	0	2	0	1
209		3	max	0	50	0	50	0	50	0	50	0	50	0	50	0
210		min	0	1	0	1	0	1	0	1	0	1	0	1	0	1
211	M36	1	max	0	50	0	50	0	50	0	50	0	50	0	50	0
212		min	0	1	0	1	0	1	0	1	0	1	0	1	0	1
213		2	max	.005	8	.078	5	.092	11	.039	2	.032	8	0	2	.026
214		min	-.037	27	-.078	11	-.092	5	-.032	8	-.039	2	-.023	33	.001	2
215		3	max	0	50	0	50	0	50	0	50	0	50	0	50	0
216		min	0	1	0	1	0	1	0	1	0	1	0	1	0	1
217	M37	1	max	0	50	0	50	0	50	0	50	0	50	0	50	0
218		min	0	1	0	1	0	1	0	1	0	1	0	1	0	1
219		2	max	0	50	0	1	0	50	0	13	0	1	0	13	0
220		min	0	1	0	2	0	1	0	1	0	2	0	1	0	2
221		3	max	0	50	0	50	0	50	0	50	0	50	0	50	0
222		min	0	1	0	1	0	1	0	1	0	1	0	1	0	1
223	M38	1	max	.38	9	.706	4	.471	9	1.568	9	1.553	3	.87	11	1.015
224		min	-.384	3	-.703	10	-.459	3	-1.553	3	-1.568	9	-.919	5	-.961	11
225		2	max	.38	9	.706	4	.472	9	.785	9	.776	3	.434	11	.508
226		min	-.384	3	-.703	10	-.457	3	-.776	3	-.785	9	-.46	5	-.48	11
227		3	max	.38	9	.706	4	.473	9	0	50	0	50	0	50	0
228		min	-.384	3	-.703	10	-.456	3	0	1	0	1	0	1	0	1
229	M39	1	max	.38	7	.47	7	.706	12	1.553	13	1.568	7	.87	5	1.015
230		min	-.384	13	-.459	13	-.703	6	-1.568	7	-1.553	13	-.919	11	-.961	5
231		2	max	.38	7	.472	7	.706	12	.776	13	.785	7	.434	5	.508
232		min	-.384	13	-.457	13	-.703	6	-.785	7	-.776	13	-.46	11	-.48	5
233		3	max	.38	7	.473	7	.706	12	0	50	0	50	0	50	0
234		min	-.384	13	-.456	13	-.703	6	0	1	0	1	0	1	0	1
235	M40	1	max	0	5	0	50	0	50	0	50	0	50	0	50	0



Envelope Member Section Stresses (Continued)

Member	Sec		Axial[ksi]	LC	v Shear[ksi]	LC	z Shear[ksi]	LC	v-Top[ksi]	LC	v-Bot[ksi]	LC	z-Top[ksi]	LC	z-Bot[ksi]	LC	
236		min	0	11	0	1	0	1	0	1	0	1	0	1	0	1	
237	2	max	0	11	0	50	0	50	0	50	0	50	0	50	0	50	
238		min	0	2	0	1	0	1	0	1	0	1	0	1	0	1	
239	3	max	0	11	0	50	0	50	0	50	0	50	0	50	0	50	
240		min	0	5	0	1	0	1	0	1	0	1	0	1	0	1	
241	M41	1	max	0	2	0	50	0	50	0	50	0	50	0	50	0	50
242		min	0	8	0	1	0	1	0	1	0	1	0	1	0	1	
243	2	max	0	2	0	50	0	50	0	50	0	50	0	50	0	50	
244		min	0	8	0	1	0	1	0	1	0	1	0	1	0	1	
245	3	max	0	2	0	50	0	50	0	50	0	50	0	50	0	50	
246		min	0	8	0	1	0	1	0	1	0	1	0	1	0	1	
247	M42	1	max	0	2	0	50	0	50	0	50	0	50	0	50	0	50
248		min	0	8	0	1	0	1	0	1	0	1	0	1	0	1	
249	2	max	0	2	0	50	0	50	0	50	0	50	0	50	0	50	
250		min	0	8	0	1	0	1	0	1	0	1	0	1	0	1	
251	3	max	0	2	0	50	0	50	0	50	0	50	0	50	0	50	
252		min	0	8	0	1	0	1	0	1	0	1	0	1	0	1	
253	M43	1	max	0	11	0	50	0	50	0	50	0	50	0	50	0	50
254		min	0	5	0	1	0	1	0	1	0	1	0	1	0	1	
255	2	max	0	11	0	50	0	50	0	50	0	50	0	50	0	50	
256		min	0	5	0	1	0	1	0	1	0	1	0	1	0	1	
257	3	max	0	11	0	50	0	50	0	50	0	50	0	50	0	50	
258		min	0	5	0	1	0	1	0	1	0	1	0	1	0	1	
259	M44	1	max	0	5	0	50	0	50	0	50	0	50	0	50	0	50
260		min	0	11	0	1	0	1	0	1	0	1	0	1	0	1	
261	2	max	0	5	0	50	0	50	0	50	0	50	0	50	0	50	
262		min	0	11	0	1	0	1	0	1	0	1	0	1	0	1	
263	3	max	0	5	0	50	0	50	0	50	0	50	0	50	0	50	
264		min	0	11	0	1	0	1	0	1	0	1	0	1	0	1	
265	M45	1	max	0	10	0	50	0	50	0	50	0	50	0	50	0	50
266		min	0	4	0	1	0	1	0	1	0	1	0	1	0	1	
267	2	max	0	10	0	50	0	50	0	50	0	50	0	50	0	50	
268		min	0	4	0	1	0	1	0	1	0	1	0	1	0	1	
269	3	max	0	6	0	50	0	50	0	50	0	50	0	50	0	50	
270		min	0	12	0	1	0	1	0	1	0	1	0	1	0	1	
271	M46	1	max	0	7	0	50	0	50	0	50	0	50	0	50	0	50
272		min	0	13	0	1	0	1	0	1	0	1	0	1	0	1	
273	2	max	0	7	0	50	0	50	0	50	0	50	0	50	0	50	
274		min	0	13	0	1	0	1	0	1	0	1	0	1	0	1	
275	3	max	0	7	0	50	0	50	0	50	0	50	0	50	0	50	
276		min	0	13	0	1	0	1	0	1	0	1	0	1	0	1	
277	M47	1	max	0	9	0	50	0	50	0	50	0	50	0	50	0	50
278		min	0	3	0	1	0	1	0	1	0	1	0	1	0	1	
279	2	max	0	9	0	50	0	50	0	50	0	50	0	50	0	50	
280		min	0	3	0	1	0	1	0	1	0	1	0	1	0	1	
281	3	max	0	9	0	50	0	50	0	50	0	50	0	50	0	50	
282		min	0	3	0	1	0	1	0	1	0	1	0	1	0	1	
283	M48	1	max	0	8	0	50	0	50	0	50	0	50	0	50	0	50
284		min	0	2	0	1	0	1	0	1	0	1	0	1	0	1	
285	2	max	0	8	0	50	0	50	0	50	0	50	0	50	0	50	
286		min	0	2	0	1	0	1	0	1	0	1	0	1	0	1	
287	3	max	0	8	0	50	0	50	0	50	0	50	0	50	0	50	
288		min	0	2	0	1	0	1	0	1	0	1	0	1	0	1	
289	M49	1	max	0	8	0	50	0	50	0	50	0	50	0	50	0	50
290		min	0	2	0	1	0	1	0	1	0	1	0	1	0	1	
291	2	max	0	8	0	50	0	50	0	50	0	50	0	50	0	50	
292		min	0	2	0	1	0	1	0	1	0	1	0	1	0	1	



Envelope Member Section Stresses (Continued)

Member	Sec		Axial[ksi]	LC	y Shear[ksi]	LC	z Shear[ksi]	LC	y-Top[ksi]	LC	y-Bot[...]	LC	z-Top[...]	LC	z-Bot[...]	LC
293	3	max	0	8	0	50	0	50	0	50	0	50	0	50	0	50
294		min	0	2	0	1	0	1	0	1	0	1	0	1	0	1
295	M50	1	max	0	8	0	50	0	50	0	50	0	50	0	50	0
296		min	0	2	0	1	0	1	0	1	0	1	0	1	0	1
297		2	max	0	8	0	50	0	50	0	50	0	50	0	50	0
298		min	0	2	0	1	0	1	0	1	0	1	0	1	0	1
299		3	max	0	8	0	50	0	50	0	50	0	50	0	50	0
300		min	0	2	0	1	0	1	0	1	0	1	0	1	0	1
301	M51	1	max	0	8	0	50	0	50	0	50	0	50	0	50	0
302		min	0	2	0	1	0	1	0	1	0	1	0	1	0	1
303		2	max	0	8	0	50	0	50	0	50	0	50	0	50	0
304		min	0	2	0	1	0	1	0	1	0	1	0	1	0	1
305		3	max	0	8	0	50	0	50	0	50	0	50	0	50	0
306		min	0	2	0	1	0	1	0	1	0	1	0	1	0	1
307	M52	1	max	0	8	0	50	0	50	0	50	0	50	0	50	0
308		min	0	2	0	1	0	1	0	1	0	1	0	1	0	1
309		2	max	0	8	0	50	0	50	0	50	0	50	0	50	0
310		min	0	2	0	1	0	1	0	1	0	1	0	1	0	1
311		3	max	0	8	0	50	0	50	0	50	0	50	0	50	0
312		min	0	2	0	1	0	1	0	1	0	1	0	1	0	1
313	M53	1	max	0	8	0	50	0	50	0	50	0	50	0	50	0
314		min	0	2	0	1	0	1	0	1	0	1	0	1	0	1
315		2	max	0	8	0	50	0	50	0	50	0	50	0	50	0
316		min	0	2	0	1	0	1	0	1	0	1	0	1	0	1
317		3	max	0	8	0	50	0	50	0	50	0	50	0	50	0
318		min	0	2	0	1	0	1	0	1	0	1	0	1	0	1
319	M54	1	max	0	5	0	50	0	50	0	50	0	50	0	50	0
320		min	0	11	0	1	0	1	0	1	0	1	0	1	0	1
321		2	max	0	11	0	50	0	50	0	50	0	50	0	50	0
322		min	0	1	0	1	0	1	0	1	0	1	0	1	0	1
323		3	max	0	11	0	50	0	50	0	50	0	50	0	50	0
324		min	0	5	0	1	0	1	0	1	0	1	0	1	0	1
325	M55	1	max	0	2	0	50	0	50	0	50	0	50	0	50	0
326		min	0	8	0	1	0	1	0	1	0	1	0	1	0	1
327		2	max	0	2	0	50	0	50	0	50	0	50	0	50	0
328		min	0	8	0	1	0	1	0	1	0	1	0	1	0	1
329		3	max	0	2	0	50	0	50	0	50	0	50	0	50	0
330		min	0	8	0	1	0	1	0	1	0	1	0	1	0	1
331	M56	1	max	0	2	0	50	0	50	0	50	0	50	0	50	0
332		min	0	8	0	1	0	1	0	1	0	1	0	1	0	1
333		2	max	0	2	0	50	0	50	0	50	0	50	0	50	0
334		min	0	8	0	1	0	1	0	1	0	1	0	1	0	1
335		3	max	0	2	0	50	0	50	0	50	0	50	0	50	0
336		min	0	8	0	1	0	1	0	1	0	1	0	1	0	1
337	M57	1	max	0	11	0	50	0	50	0	50	0	50	0	50	0
338		min	0	5	0	1	0	1	0	1	0	1	0	1	0	1
339		2	max	0	11	0	50	0	50	0	50	0	50	0	50	0
340		min	0	5	0	1	0	1	0	1	0	1	0	1	0	1
341		3	max	0	11	0	50	0	50	0	50	0	50	0	50	0
342		min	0	5	0	1	0	1	0	1	0	1	0	1	0	1
343	M58	1	max	0	5	0	50	0	50	0	50	0	50	0	50	0
344		min	0	11	0	1	0	1	0	1	0	1	0	1	0	1
345		2	max	0	5	0	50	0	50	0	50	0	50	0	50	0
346		min	0	11	0	1	0	1	0	1	0	1	0	1	0	1
347		3	max	0	5	0	50	0	50	0	50	0	50	0	50	0
348		min	0	11	0	1	0	1	0	1	0	1	0	1	0	1
349	M59	1	max	0	10	0	50	0	50	0	50	0	50	0	50	0

Envelope Member Section Stresses (Continued)

Member	Sec		Axial[ksil]	LC	v Shear[ksil]	LC	z Shear[ksil]	LC	v-Top[ksil]	LC	v-Bot[ksil]	LC	z-Top[ksil]	LC	z-Bot[ksil]	LC
350		min	0	4	0	1	0	1	0	1	0	1	0	1	0	1
351	2	max	0	10	0	50	0	50	0	50	0	50	0	50	0	50
352		min	0	4	0	1	0	1	0	1	0	1	0	1	0	1
353	3	max	0	6	0	50	0	50	0	50	0	50	0	50	0	50
354		min	0	12	0	1	0	1	0	1	0	1	0	1	0	1
355	M60	1	max	0	7	0	50	0	50	0	50	0	50	0	50	0
356		min	0	13	0	1	0	1	0	1	0	1	0	1	0	1
357	2	max	0	7	0	50	0	50	0	50	0	50	0	50	0	50
358		min	0	13	0	1	0	1	0	1	0	1	0	1	0	1
359	3	max	0	7	0	50	0	50	0	50	0	50	0	50	0	50
360		min	0	13	0	1	0	1	0	1	0	1	0	1	0	1
361	M61	1	max	0	9	0	50	0	50	0	50	0	50	0	50	0
362		min	0	3	0	1	0	1	0	1	0	1	0	1	0	1
363	2	max	0	9	0	50	0	50	0	50	0	50	0	50	0	50
364		min	0	3	0	1	0	1	0	1	0	1	0	1	0	1
365	3	max	0	9	0	50	0	50	0	50	0	50	0	50	0	50
366		min	0	3	0	1	0	1	0	1	0	1	0	1	0	1
367	M62	1	max	0	5	0	50	0	50	0	50	0	50	0	50	0
368		min	0	11	0	1	0	1	0	1	0	1	0	1	0	1
369	2	max	0	11	0	50	0	50	0	50	0	50	0	50	0	50
370		min	0	1	0	1	0	1	0	1	0	1	0	1	0	1
371	3	max	0	11	0	50	0	50	0	50	0	50	0	50	0	50
372		min	0	5	0	1	0	1	0	1	0	1	0	1	0	1
373	M63	1	max	0	2	0	50	0	50	0	50	0	50	0	50	0
374		min	0	8	0	1	0	1	0	1	0	1	0	1	0	1
375	2	max	0	2	0	50	0	50	0	50	0	50	0	50	0	50
376		min	0	8	0	1	0	1	0	1	0	1	0	1	0	1
377	3	max	0	2	0	50	0	50	0	50	0	50	0	50	0	50
378		min	0	8	0	1	0	1	0	1	0	1	0	1	0	1
379	M64	1	max	0	2	0	50	0	50	0	50	0	50	0	50	0
380		min	0	8	0	1	0	1	0	1	0	1	0	1	0	1
381	2	max	0	2	0	50	0	50	0	50	0	50	0	50	0	50
382		min	0	8	0	1	0	1	0	1	0	1	0	1	0	1
383	3	max	0	2	0	50	0	50	0	50	0	50	0	50	0	50
384		min	0	8	0	1	0	1	0	1	0	1	0	1	0	1
385	M65	1	max	0	11	0	50	0	50	0	50	0	50	0	50	0
386		min	0	5	0	1	0	1	0	1	0	1	0	1	0	1
387	2	max	0	11	0	50	0	50	0	50	0	50	0	50	0	50
388		min	0	5	0	1	0	1	0	1	0	1	0	1	0	1
389	3	max	0	11	0	50	0	50	0	50	0	50	0	50	0	50
390		min	0	5	0	1	0	1	0	1	0	1	0	1	0	1
391	M66	1	max	0	5	0	50	0	50	0	50	0	50	0	50	0
392		min	0	11	0	1	0	1	0	1	0	1	0	1	0	1
393	2	max	0	5	0	50	0	50	0	50	0	50	0	50	0	50
394		min	0	11	0	1	0	1	0	1	0	1	0	1	0	1
395	3	max	0	5	0	50	0	50	0	50	0	50	0	50	0	50
396		min	0	11	0	1	0	1	0	1	0	1	0	1	0	1
397	M67	1	max	0	10	0	50	0	50	0	50	0	50	0	50	0
398		min	0	4	0	1	0	1	0	1	0	1	0	1	0	1
399	2	max	0	10	0	50	0	50	0	50	0	50	0	50	0	50
400		min	0	4	0	1	0	1	0	1	0	1	0	1	0	1
401	3	max	0	6	0	50	0	50	0	50	0	50	0	50	0	50
402		min	0	12	0	1	0	1	0	1	0	1	0	1	0	1
403	M68	1	max	0	7	0	50	0	50	0	50	0	50	0	50	0
404		min	0	13	0	1	0	1	0	1	0	1	0	1	0	1
405	2	max	0	7	0	50	0	50	0	50	0	50	0	50	0	50
406		min	0	13	0	1	0	1	0	1	0	1	0	1	0	1



Envelope Member Section Stresses (Continued)

Member	Sec		Axial[ksi]	LC	y Shear[ksi]	LC	z Shear[ksi]	LC	y-Top[ksi]	LC	y-Bot[...]	LC	z-Top[...]	LC	z-Bot[...]	LC
407	3	max	0	7	0	50	0	50	0	50	0	50	0	50	0	50
408		min	0	13	0	1	0	1	0	1	0	1	0	1	0	1
409	M69	1	max	0	9	0	50	0	50	0	50	0	50	0	50	0
410		min	0	3	0	1	0	1	0	1	0	1	0	1	0	1
411		2	max	0	9	0	50	0	50	0	50	0	50	0	50	0
412		min	0	3	0	1	0	1	0	1	0	1	0	1	0	1
413		3	max	0	9	0	50	0	50	0	50	0	50	0	50	0
414		min	0	3	0	1	0	1	0	1	0	1	0	1	0	1
415	M70	1	max	0	5	0	50	0	50	0	50	0	50	0	50	0
416		min	0	10	0	1	0	1	0	1	0	1	0	1	0	1
417		2	max	0	12	0	50	0	50	0	50	0	50	0	50	0
418		min	0	8	0	1	0	1	0	1	0	1	0	1	0	1
419		3	max	0	12	0	50	0	50	0	50	0	50	0	50	0
420		min	0	5	0	1	0	1	0	1	0	1	0	1	0	1
421	M71	1	max	0	13	0	50	0	50	0	50	0	50	0	50	0
422		min	0	7	0	1	0	1	0	1	0	1	0	1	0	1
423		2	max	0	13	0	50	0	50	0	50	0	50	0	50	0
424		min	0	7	0	1	0	1	0	1	0	1	0	1	0	1
425		3	max	0	13	0	50	0	50	0	50	0	50	0	50	0
426		min	0	7	0	1	0	1	0	1	0	1	0	1	0	1
427	M72	1	max	0	3	0	50	0	50	0	50	0	50	0	50	0
428		min	0	8	0	1	0	1	0	1	0	1	0	1	0	1
429		2	max	0	3	0	50	0	50	0	50	0	50	0	50	0
430		min	0	8	0	1	0	1	0	1	0	1	0	1	0	1
431		3	max	0	3	0	50	0	50	0	50	0	50	0	50	0
432		min	0	8	0	1	0	1	0	1	0	1	0	1	0	1
433	M73	1	max	0	12	0	50	0	50	0	50	0	50	0	50	0
434		min	0	6	0	1	0	1	0	1	0	1	0	1	0	1
435		2	max	0	12	0	50	0	50	0	50	0	50	0	50	0
436		min	0	6	0	1	0	1	0	1	0	1	0	1	0	1
437		3	max	0	12	0	50	0	50	0	50	0	50	0	50	0
438		min	0	6	0	1	0	1	0	1	0	1	0	1	0	1
439	M74	1	max	0	4	0	50	0	50	0	50	0	50	0	50	0
440		min	0	10	0	1	0	1	0	1	0	1	0	1	0	1
441		2	max	0	4	0	50	0	50	0	50	0	50	0	50	0
442		min	0	10	0	1	0	1	0	1	0	1	0	1	0	1
443		3	max	0	4	0	50	0	50	0	50	0	50	0	50	0
444		min	0	10	0	1	0	1	0	1	0	1	0	1	0	1
445	M75	1	max	0	10	0	50	0	50	0	50	0	50	0	50	0
446		min	0	4	0	1	0	1	0	1	0	1	0	1	0	1
447		2	max	0	10	0	50	0	50	0	50	0	50	0	50	0
448		min	0	4	0	1	0	1	0	1	0	1	0	1	0	1
449		3	max	0	6	0	50	0	50	0	50	0	50	0	50	0
450		min	0	12	0	1	0	1	0	1	0	1	0	1	0	1
451	M76	1	max	0	7	0	50	0	50	0	50	0	50	0	50	0
452		min	0	13	0	1	0	1	0	1	0	1	0	1	0	1
453		2	max	0	7	0	50	0	50	0	50	0	50	0	50	0
454		min	0	13	0	1	0	1	0	1	0	1	0	1	0	1
455		3	max	0	7	0	50	0	50	0	50	0	50	0	50	0
456		min	0	13	0	1	0	1	0	1	0	1	0	1	0	1
457	M77	1	max	0	9	0	50	0	50	0	50	0	50	0	50	0
458		min	0	3	0	1	0	1	0	1	0	1	0	1	0	1
459		2	max	0	9	0	50	0	50	0	50	0	50	0	50	0
460		min	0	3	0	1	0	1	0	1	0	1	0	1	0	1
461		3	max	0	9	0	50	0	50	0	50	0	50	0	50	0
462		min	0	3	0	1	0	1	0	1	0	1	0	1	0	1
463	M78	1	max	0	5	0	50	0	50	0	50	0	50	0	50	0



Envelope Member Section Stresses (Continued)

Member	Sec		Axial[ksi]	LC	v Shear[ksi]	LC	z Shear[ksi]	LC	v-Top[ksi]	LC	v-Bot[ksi]	LC	z-Top[ksi]	LC	z-Bot[ksi]	LC
464		min	0	10	0	1	0	1	0	1	0	1	0	1	0	1
465	2	max	0	12	0	50	0	50	0	50	0	50	0	50	0	50
466		min	0	7	0	1	0	1	0	1	0	1	0	1	0	1
467	3	max	0	12	0	50	0	50	0	50	0	50	0	50	0	50
468		min	0	5	0	1	0	1	0	1	0	1	0	1	0	1
469	M79	1	max	0	2	0	50	0	50	0	50	0	50	0	50	0
470		min	0	8	0	1	0	1	0	1	0	1	0	1	0	1
471	2	max	0	2	0	50	0	50	0	50	0	50	0	50	0	50
472		min	0	8	0	1	0	1	0	1	0	1	0	1	0	1
473	3	max	0	2	0	50	0	50	0	50	0	50	0	50	0	50
474		min	0	8	0	1	0	1	0	1	0	1	0	1	0	1
475	M80	1	max	0	2	0	50	0	50	0	50	0	50	0	50	0
476		min	0	8	0	1	0	1	0	1	0	1	0	1	0	1
477	2	max	0	2	0	50	0	50	0	50	0	50	0	50	0	50
478		min	0	8	0	1	0	1	0	1	0	1	0	1	0	1
479	3	max	0	2	0	50	0	50	0	50	0	50	0	50	0	50
480		min	0	8	0	1	0	1	0	1	0	1	0	1	0	1
481	M81	1	max	0	12	0	50	0	50	0	50	0	50	0	50	0
482		min	0	6	0	1	0	1	0	1	0	1	0	1	0	1
483	2	max	0	12	0	50	0	50	0	50	0	50	0	50	0	50
484		min	0	6	0	1	0	1	0	1	0	1	0	1	0	1
485	3	max	0	12	0	50	0	50	0	50	0	50	0	50	0	50
486		min	0	6	0	1	0	1	0	1	0	1	0	1	0	1
487	M82	1	max	0	4	0	50	0	50	0	50	0	50	0	50	0
488		min	0	10	0	1	0	1	0	1	0	1	0	1	0	1
489	2	max	0	4	0	50	0	50	0	50	0	50	0	50	0	50
490		min	0	10	0	1	0	1	0	1	0	1	0	1	0	1
491	3	max	0	4	0	50	0	50	0	50	0	50	0	50	0	50
492		min	0	10	0	1	0	1	0	1	0	1	0	1	0	1
493	M83	1	max	0	10	0	50	0	50	0	50	0	50	0	50	0
494		min	0	3	0	1	0	1	0	1	0	1	0	1	0	1
495	2	max	0	10	0	50	0	50	0	50	0	50	0	50	0	50
496		min	0	3	0	1	0	1	0	1	0	1	0	1	0	1
497	3	max	0	7	0	50	0	50	0	50	0	50	0	50	0	50
498		min	0	12	0	1	0	1	0	1	0	1	0	1	0	1
499	M84	1	max	0	7	0	50	0	50	0	50	0	50	0	50	0
500		min	0	13	0	1	0	1	0	1	0	1	0	1	0	1
501	2	max	0	7	0	50	0	50	0	50	0	50	0	50	0	50
502		min	0	13	0	1	0	1	0	1	0	1	0	1	0	1
503	3	max	0	7	0	50	0	50	0	50	0	50	0	50	0	50
504		min	0	13	0	1	0	1	0	1	0	1	0	1	0	1
505	M85	1	max	0	9	0	50	0	50	0	50	0	50	0	50	0
506		min	0	3	0	1	0	1	0	1	0	1	0	1	0	1
507	2	max	0	9	0	50	0	50	0	50	0	50	0	50	0	50
508		min	0	3	0	1	0	1	0	1	0	1	0	1	0	1
509	3	max	0	9	0	50	0	50	0	50	0	50	0	50	0	50
510		min	0	3	0	1	0	1	0	1	0	1	0	1	0	1
511	M86	1	max	0	5	0	50	0	50	0	50	0	50	0	50	0
512		min	0	10	0	1	0	1	0	1	0	1	0	1	0	1
513	2	max	0	12	0	50	0	50	0	50	0	50	0	50	0	50
514		min	0	7	0	1	0	1	0	1	0	1	0	1	0	1
515	3	max	0	12	0	50	0	50	0	50	0	50	0	50	0	50
516		min	0	5	0	1	0	1	0	1	0	1	0	1	0	1
517	M87	1	max	0	2	0	50	0	50	0	50	0	50	0	50	0
518		min	0	8	0	1	0	1	0	1	0	1	0	1	0	1
519	2	max	0	2	0	50	0	50	0	50	0	50	0	50	0	50
520		min	0	8	0	1	0	1	0	1	0	1	0	1	0	1



Envelope Member Section Stresses (Continued)

Member	Sec		Axial[ksi]	LC	y Shear[ksi]	LC	z Shear[ksi]	LC	y-Top[ksi]	LC	y-Bot[...]	LC	z-Top[...]	LC	z-Bot[...]	LC
521	3	max	0	2	0	50	0	50	0	50	0	50	0	50	0	50
522		min	0	8	0	1	0	1	0	1	0	1	0	1	0	1
523	M88	1	max	0	2	0	50	0	50	0	50	0	50	0	50	0
524		min	0	8	0	1	0	1	0	1	0	1	0	1	0	1
525		2	max	0	2	0	50	0	50	0	50	0	50	0	50	0
526		min	0	8	0	1	0	1	0	1	0	1	0	1	0	1
527		3	max	0	2	0	50	0	50	0	50	0	50	0	50	0
528		min	0	8	0	1	0	1	0	1	0	1	0	1	0	1
529	M89	1	max	0	12	0	50	0	50	0	50	0	50	0	50	0
530		min	0	6	0	1	0	1	0	1	0	1	0	1	0	1
531		2	max	0	12	0	50	0	50	0	50	0	50	0	50	0
532		min	0	6	0	1	0	1	0	1	0	1	0	1	0	1
533		3	max	0	12	0	50	0	50	0	50	0	50	0	50	0
534		min	0	6	0	1	0	1	0	1	0	1	0	1	0	1
535	M90	1	max	0	4	0	50	0	50	0	50	0	50	0	50	0
536		min	0	10	0	1	0	1	0	1	0	1	0	1	0	1
537		2	max	0	4	0	50	0	50	0	50	0	50	0	50	0
538		min	0	10	0	1	0	1	0	1	0	1	0	1	0	1
539		3	max	0	4	0	50	0	50	0	50	0	50	0	50	0
540		min	0	10	0	1	0	1	0	1	0	1	0	1	0	1
541	M91	1	max	0	10	0	50	0	50	0	50	0	50	0	50	0
542		min	0	3	0	1	0	1	0	1	0	1	0	1	0	1
543		2	max	0	10	0	50	0	50	0	50	0	50	0	50	0
544		min	0	3	0	1	0	1	0	1	0	1	0	1	0	1
545		3	max	0	7	0	50	0	50	0	50	0	50	0	50	0
546		min	0	12	0	1	0	1	0	1	0	1	0	1	0	1
547	M92	1	max	0	7	0	50	0	50	0	50	0	50	0	50	0
548		min	0	13	0	1	0	1	0	1	0	1	0	1	0	1
549		2	max	0	7	0	50	0	50	0	50	0	50	0	50	0
550		min	0	13	0	1	0	1	0	1	0	1	0	1	0	1
551		3	max	0	7	0	50	0	50	0	50	0	50	0	50	0
552		min	0	13	0	1	0	1	0	1	0	1	0	1	0	1
553	M93	1	max	0	9	0	50	0	50	0	50	0	50	0	50	0
554		min	0	3	0	1	0	1	0	1	0	1	0	1	0	1
555		2	max	0	9	0	50	0	50	0	50	0	50	0	50	0
556		min	0	3	0	1	0	1	0	1	0	1	0	1	0	1
557		3	max	0	9	0	50	0	50	0	50	0	50	0	50	0
558		min	0	3	0	1	0	1	0	1	0	1	0	1	0	1

Envelope AISC 15th(360-16): LRFD Steel Code Checks

Member	Shape	Code Check	Loc...	L...Shea...	Loc.....	L...phi*Pn...	phi*Pn...	phi*M...	phi*M.....	Eqn	
1	M1	PIPE 2.0	.144	78....	2 .023	78....	13 13787...	32130	1.872	1.872	1 H1-1b
2	M2	PIPE 2.0	.162	78....	2 .022	31....	13 13787...	32130	1.872	1.872	1 H1-1b
3	M3	PIPE 2.0	.162	78....	2 .022	31....	13 13787...	32130	1.872	1.872	1 H1-1b
4	M4	PIPE 2.0	.586	79....	8 .040	79....	8 5018....	32130	1.872	1.872	1 H1-1b
5	M5	PIPE 2.0	.597	79....	8 .041	79....	8 5018....	32130	1.872	1.872	1 H1-1b
6	M6	PIPE 2.0	.597	79....	8 .041	79....	8 5018....	32130	1.872	1.872	1 H1-1b
7	M7	PIPE 3.0	.412	79....	2 .044	80....	12 57075...	65205	5.749	5.749	1 H1-1b
8	M8	PIPE 3.0	.411	79....	2 .042	80....	13 57075...	65205	5.749	5.749	1 H1-1b
9	M9	PIPE 3.0	.411	79....	2 .042	80....	13 57075...	65205	5.749	5.749	1 H1-1b
10	M10	L3X3X3	.083	.98	5 .383	5.4... z	13 28622...	35316	1.32	2.833	4...H2-1
11	M11	L3X3X3	.079	1.4...	5 .284	1.0... z	4 28622...	35316	1.32	2.833	1...H2-1
12	M12	L3X3X3	.141	13....	12 .293	1.8... z	3 28482...	35316	1.32	2.833	2...H2-1
13	M13	L3X3X3	.137	0	4 .058	.092 y	4 28612...	35316	1.32	2.905	1...H2-1
14	M14	L3X3X3	.138	0	12 .058	.276 z	12 28612...	35316	1.32	2.833	1...H2-1



Company : Jacobs Telecommunications, Inc.
 Designer : H. Bedane
 Job Number : EP5TRFWL - Tulip Ave
 Model Name : Existing Wall Mount

May 6, 2022
 10:25 AM
 Checked By: B. Bartlett

Envelope AISC 15th(360-16): LRFD Steel Code Checks (Continued)

Member	Shape	Code Check	Loc...	L...	Shea...	Loc.....	L...	phi*Pn...	phi*Pn...	phi*M...	phi*M.....	Eqn
15	M15	L3X3X3	.98	5	.372	.551	y 2	28622...	35316	1.32	2.833	4...H2-1
16	M16	L3X3X3	1.4...	5	.264	1.0...	z 3	28622...	35316	1.32	2.833	1...H2-1
17	M17	L3X3X3	13...	6	.289	1.5...	z 3	28482...	35316	1.32	2.833	3 H2-1
18	M18	L3X3X3	0	10	.055	.061	y 4	28612...	35316	1.32	2.833	1...H2-1
19	M19	L3X3X3	0	6	.055	0	z 12	28612...	35316	1.32	2.833	1...H2-1
20	M20	L3X3X3	.98	5	.372	.551	y 2	28622...	35316	1.32	2.833	4...H2-1
21	M21	L3X3X3	1.4...	5	.264	1.0...	z 3	28622...	35316	1.32	2.833	1...H2-1
22	M22	L3X3X3	13...	6	.289	1.5...	z 3	28482...	35316	1.32	2.833	3 H2-1
23	M23	L3X3X3	0	10	.055	0	y 4	28612...	35316	1.32	2.833	1...H2-1
24	M24	L3X3X3	0	6	.055	1.8...	z 12	28612...	35316	1.32	2.833	1...H2-1
25	M25	L3X3X3	.98	5	.177	5.4...	z 13	28622...	35316	1.32	2.833	4...H2-1
26	M26	L3X3X3	1.4...	5	.137	6.9...	z 13	28622...	35316	1.32	2.833	1...H2-1
27	M27	L3X3X3	5.3...	9	.430	1.5...	z 9	28482...	35316	1.32	2.905	2...H2-1
28	M28	L3X3X3	0	10	.032	0	y 4	28612...	35316	1.32	2.833	1...H2-1
29	M29	L3X3X3	0	6	.032	0	z 12	28612...	35316	1.32	2.833	1...H2-1
30	M30	L3X3X3	.98	5	.172	5.4...	z 13	28622...	35316	1.32	2.833	4...H2-1
31	M31	L3X3X3	1.4...	5	.128	6.9...	z 13	28622...	35316	1.32	2.833	1...H2-1
32	M32	L3X3X3	5.3...	9	.432	1.5...	z 9	28482...	35316	1.32	2.905	2...H2-1
33	M33	L3X3X3	0	10	.030	1.3...	y 4	28612...	35316	1.32	2.833	1...H2-1
34	M34	L3X3X3	0	6	.030	0	z 12	28612...	35316	1.32	2.833	1...H2-1
35	M35	L3X3X3	.98	5	.172	5.4...	z 13	28622...	35316	1.32	2.833	4...H2-1
36	M36	L3X3X3	1.4...	5	.128	6.9...	z 13	28622...	35316	1.32	2.833	1...H2-1
37	M37	L3X3X3	5.3...	9	.432	1.5...	z 9	28482...	35316	1.32	2.905	2...H2-1
38	M38	L3X3X3	0	10	.030	0	y 4	28612...	35316	1.32	2.833	1...H2-1
39	M39	L3X3X3	0	6	.030	.122	z 12	28612...	35316	1.32	2.833	1...H2-1

Envelope Plate/Shell Principal Stresses

Plate	Sur...	Sigma1 [ksi]	LC Sigma2 [ksi]	LC Tau Max [...]	LC Angle [rad]	LC Von Mises [ksi]	LC
No Data to Print ...							



WIND/ICE/SERVICE LOADING
 ANTENNA MOUNTING SYSTEM
 ANSI/TIA-222-H

Project Number:	EP5TRFWL
Site Name:	Tulip Ave
Engineer:	H. Bedane
Date:	05/05/2022
Carrier:	AT&T
Reviewed By:	B. Bartlett

Input Data

Front

Manufacturer Model #	COMMSCOPE NNHH-65A-R4		
Length	55.1	in	
Width	19.6	in	
Depth	7.8	in	
Weight	67.2	lb	
Design Ice Thickness (t _i)	1	in	
Structure Type	B	(S, G, M, B)	
Structure Height (h)	112	ft	
Antenna Centerline (z)	129	ft	
Basic Wind Speed (V)	113	mph (w/o ice)	
Basic Wind Speed (V _i)	40	mph (w/ ice)	
Basic Wind Speed (V _s)	30	mph (service)	
Risk Category	II	(I, II, III, IV)	
Exposure Category	C	(B, C or D)	
Topographic Category	1	(1, 2, 3 or 4)	
Crest Height (H)	0	ft	
Shape	F	(R / F / S)	
Length / Width	2.811	(w/o ice)	
Length / Width	2.622	(w/ ice)	
C _a	1.214	(w/o ice)	
C _a	1.205	(w/ ice)	
C _a	1.214	(service)	
(EPA) _A	8.193	ft ² (w/o ice)	
(EPA) _A	9.466	ft ² (w/ ice)	
(EPA) _A	8.193	ft ² (service)	
F _A = q _z G _h (EPA) _A	339.744	lb (w/o ice)	
F _A = q _z G _h (EPA) _A	49.184	lb (w/ ice)	
F _A = q _z G _h (EPA) _A	23.946	lb (service)	
Ice Weight	142.991	lb	
Total Weight	210.191	lb (w/ ice)	
Equations			
K _z = 2.01[z/z _g] ^(2/α)	1.335	K _{zmin} ≤ K _z ≤ 2.01	
K _h = e ^{-(0.7)(z)/H}	1.000		
K _{zt} = [1 + (K _c K _i)/K _h] ²	1.000		
K _{iz} = [z/33] ^(0.10)	1.146	K _{iz} ≤ 1.4	
t _{iz} = (t _i)(I)(K _{iz})(K _{zt}) ^(0.35)	1.146	in (w/ ice)	
C = (K _{zt} K _z K _g) ^{0.5} (V)(D)	213.278	(w/o ice)	
C = (K _{zt} K _z K _g) ^{0.5} (V _i)(D)	75.497	(w/ ice)	
C = (K _{zt} K _z K _g) ^{0.5} (V)(D)	56.622	(service)	
G _h =	1.00		
K _d =	0.95		
K _s =	1.00		
K _a =	0.90		
K _e = e ^{-0.0000362zs}	1.00		
q _z = 0.00256K _z K _{zt} K _s K _d V ²	41.47	psf (w/o ice)	
q _z = 0.00256K _z K _{zt} K _s K _d V _i ²	5.20	psf (w/ ice)	
q _z = 0.00256K _z K _{zt} K _s K _d V _s ²	2.92	psf (service)	
Position	2	x	1
	4	x	1
		x	
		x	

Side

Manufacturer Model #	COMMSCOPE NNHH-65A-R4		
Length	55.1	in	
Width	19.6	in	
Depth	7.8	in	
Weight	67.2	lb	
Design Ice Thickness (t _i)	1	in	
Structure Type	B	(S, G, M, B)	
Structure Height (h)	112	ft	
Antenna Centerline (z)	129	ft	
Basic Wind Speed (V)	113	mph (w/o ice)	
Basic Wind Speed (V _i)	40	mph (w/ ice)	
Basic Wind Speed (V _s)	30	mph (service)	
Risk Category	II	(I, II, III, IV)	
Exposure Category	C	(B, C or D)	
Topographic Category	1	(1, 2, 3 or 4)	
Crest Height (H)	0	ft	
Shape	F	(R / F / S)	
Length / Width	7.064	(w/o ice)	
Length / Width	5.687	(w/ ice)	
C _a	1.402	(w/o ice)	
C _a	1.342	(w/ ice)	
C _a	1.402	(service)	
(EPA) _A	3.766	ft ² (w/o ice)	
(EPA) _A	4.857	ft ² (w/ ice)	
(EPA) _A	3.766	ft ² (service)	
F _A = q _z G _h (EPA) _A	156.179	lb (w/o ice)	
F _A = q _z G _h (EPA) _A	25.236	lb (w/ ice)	
F _A = q _z G _h (EPA) _A	11.008	lb (service)	
Ice Weight	142.991	lb	
Total Weight	210.191	lb (w/ ice)	
Equations			
K _z = 2.01[z/z _g] ^(2/α)	1.335	K _{zmin} ≤ K _z ≤ 2.01	
K _h = e ^{-(0.7)(z)/H}	1.000		
K _{zt} = [1 + (K _c K _i)/K _h] ²	1.000		
K _{iz} = [z/33] ^(0.10)	1.146	K _{iz} ≤ 1.4	
t _{iz} = (t _i)(I)(K _{iz})(K _{zt}) ^(0.35)	1.146	in (w/ ice)	
C = (K _{zt} K _z K _g) ^{0.5} (V)(D)	84.876	(w/o ice)	
C = (K _{zt} K _z K _g) ^{0.5} (V _i)(D)	30.045	(w/ ice)	
C = (K _{zt} K _z K _g) ^{0.5} (V)(D)	22.533	(service)	
G _h =	1.00		
K _d =	0.95		
K _s =	1.00		
K _a =	0.90		
K _e = e ^{-0.0000362zs}	1.00		
q _z = 0.00256K _z K _{zt} K _s K _d V ²	41.467	psf (w/o ice)	
q _z = 0.00256K _z K _{zt} K _s K _d V _i ²	5.196	psf (w/ ice)	
q _z = 0.00256K _z K _{zt} K _s K _d V _s ²	2.923	psf (service)	
Position	2	x	1
	4	x	1
		x	
		x	



WIND/ICE/SERVICE LOADING
 ANTENNA MOUNTING SYSTEM
 ANSI/TIA-222-H

Project Number:	EP5TRFWL
Site Name:	Tulip Ave
Engineer:	H. Bedane
Date:	05/05/2022
Carrier:	AT&T
Reviewed By:	B. Bartlett

Input Data

Front

Manufacturer Model #	NOKIA AEQK		
Length	29.53	in	
Width	17.72	in	
Depth	9.53	in	
Weight	99.21	lb	
Design Ice Thickness (t _i)	1	in	
Structure Type	B	(S, G, M, B)	
Structure Height (h)	112	ft	
Antenna Centerline (z)	129	ft	
Basic Wind Speed (V)	113	mph (w/o ice)	
Basic Wind Speed (V _i)	40	mph (w/ ice)	
Basic Wind Speed (V _s)	30	mph (service)	
Risk Category	II	(I, II, III, IV)	
Exposure Category	C	(B, C or D)	
Topographic Category	1	(1, 2, 3 or 4)	
Crest Height (H)	0	ft	
Shape	F	(R / F / S)	
Length / Width	1.666	(w/o ice)	
Length / Width	1.590	(w/ ice)	
C _a	1.200	(w/o ice)	
C _a	1.200	(w/ ice)	
C _a	1.200	(service)	
(EPA) _A	3.925	ft ² (w/o ice)	
(EPA) _A	4.776	ft ² (w/ ice)	
(EPA) _A	3.925	ft ² (service)	
F _A = q _z G _h (EPA) _A	162.740	lb (w/o ice)	
F _A = q _z G _h (EPA) _A	24.817	lb (w/ ice)	
F _A = q _z G _h (EPA) _A	11.470	lb (service)	
Ice Weight	73.275	lb	
Total Weight	172.485	lb (w/ ice)	
Equations			
K _z = 2.01[z/z _d] ^(2/α)	1.335	K _{zmin} ≤ K _z ≤ 2.01	
K _h = e ^[(7)(z)/H]	1.000		
K _{zt} = [1+(K _z K _h)/K _h] ²	1.000		
K _{iz} = [z/33] ^(0.10)	1.146	K _{iz} ≤ 1.4	
t _{iz} = (t _i)(I)(K _{iz})(K _{zt}) ^(0.35)	1.146	in (w/ ice)	
C = (K _{zt} K _z K _e) ^{0.5} (V)(D)	192.821	(w/o ice)	
C = (K _{zt} K _z K _e) ^{0.5} (V _i)(D)	68.255	(w/ ice)	
C = (K _{zt} K _z K _e) ^{0.5} (V)(D)	51.191	(service)	
G _h =	1.00		
K _d =	0.95		
K _s =	1.00		
K _a =	0.90		
K _e = e ^{-0.0000362z_s}	1.00		
q _z = 0.00256K _z K _{zt} K _s K _e K _d V ²	41.47	psf (w/o ice)	
q _z = 0.00256K _z K _{zt} K _s K _e K _d V _i ²	5.20	psf (w/ ice)	
q _z = 0.00256K _z K _{zt} K _s K _e K _d V _s ²	2.92	psf (service)	
Position	1	x	1
		x	
		x	
		x	

Side

Manufacturer Model #	NOKIA AEQK		
Length	29.53	in	
Width	17.72	in	
Depth	9.53	in	
Weight	99.21	lb	
Design Ice Thickness (t _i)	1	in	
Structure Type	B	(S, G, M, B)	
Structure Height (h)	112	ft	
Antenna Centerline (z)	129	ft	
Basic Wind Speed (V)	113	mph (w/o ice)	
Basic Wind Speed (V _i)	40	mph (w/ ice)	
Basic Wind Speed (V _s)	30	mph (service)	
Risk Category	II	(I, II, III, IV)	
Exposure Category	C	(B, C or D)	
Topographic Category	1	(1, 2, 3 or 4)	
Crest Height (H)	0	ft	
Shape	F	(R / F / S)	
Length / Width	3.099	(w/o ice)	
Length / Width	2.692	(w/ ice)	
C _a	1.227	(w/o ice)	
C _a	1.209	(w/ ice)	
C _a	1.227	(service)	
(EPA) _A	2.157	ft ² (w/o ice)	
(EPA) _A	2.842	ft ² (w/ ice)	
(EPA) _A	2.157	ft ² (service)	
F _A = q _z G _h (EPA) _A	89.464	lb (w/o ice)	
F _A = q _z G _h (EPA) _A	14.765	lb (w/ ice)	
F _A = q _z G _h (EPA) _A	6.306	lb (service)	
Ice Weight	73.275	lb	
Total Weight	172.485	lb (w/ ice)	
Equations			
K _z = 2.01[z/z _d] ^(2/α)	1.335	K _{zmin} ≤ K _z ≤ 2.01	
K _h = e ^[(7)(z)/H]	1.000		
K _{zt} = [1+(K _z K _h)/K _h] ²	1.000		
K _{iz} = [z/33] ^(0.10)	1.146	K _{iz} ≤ 1.4	
t _{iz} = (t _i)(I)(K _{iz})(K _{zt}) ^(0.35)	1.146	in (w/ ice)	
C = (K _{zt} K _z K _e) ^{0.5} (V)(D)	103.701	(w/o ice)	
C = (K _{zt} K _z K _e) ^{0.5} (V _i)(D)	36.708	(w/ ice)	
C = (K _{zt} K _z K _e) ^{0.5} (V)(D)	27.531	(service)	
G _h =	1.00		
K _d =	0.95		
K _s =	1.00		
K _a =	0.90		
K _e = e ^{-0.0000362z_s}	1.00		
q _z = 0.00256K _z K _{zt} K _s K _e K _d V ²	41.467	psf (w/o ice)	
q _z = 0.00256K _z K _{zt} K _s K _e K _d V _i ²	5.196	psf (w/ ice)	
q _z = 0.00256K _z K _{zt} K _s K _e K _d V _s ²	2.923	psf (service)	
Position	1	x	1
		x	
		x	
		x	



WIND/ICE/SERVICE LOADING
 ANTENNA MOUNTING SYSTEM
 ANSI/TIA-222-H

Project Number:	EP5TRFWL
Site Name:	Tulip Ave
Engineer:	H. Bedane
Date:	05/05/2022
Carrier:	AT&T
Reviewed By:	B. Bartlett

Input Data

Front

Manufacturer Model #	NOKIA AEUQ		
Length	29.5	in	
Width	17.7	in	
Depth	9.5	in	
Weight	99.21	lb	
Design Ice Thickness (t _i)	1	in	
Structure Type	B	(S, G, M, B)	
Structure Height (h)	112	ft	
Antenna Centerline (z)	129	ft	
Basic Wind Speed (V)	113	mph (w/o ice)	
Basic Wind Speed (V _i)	40	mph (w/ ice)	
Basic Wind Speed (V _s)	30	mph (service)	
Risk Category	II	(I, II, III, IV)	
Exposure Category	C	(B, C or D)	
Topographic Category	1	(1, 2, 3 or 4)	
Crest Height (H)	0	ft	
Shape	F	(R / F / S)	
Length / Width	1.667	(w/o ice)	
Length / Width	1.590	(w/ ice)	
C _a	1.200	(w/o ice)	
C _a	1.200	(w/ ice)	
C _a	1.200	(service)	
(EPA) _A	3.916	ft ² (w/o ice)	
(EPA) _A	4.767	ft ² (w/ ice)	
(EPA) _A	3.916	ft ² (service)	
F _A = q _z G _h (EPA) _A	162.391	lb (w/o ice)	
F _A = q _z G _h (EPA) _A	24.769	lb (w/ ice)	
F _A = q _z G _h (EPA) _A	11.446	lb (service)	
Ice Weight	73.091	lb	
Total Weight	172.301	lb (w/ ice)	
Equations			
K _z = 2.01[z/z _d] ^(2/α)	1.335	K _{zmin} ≤ K _z ≤ 2.01	
K _h = e ^[(7)(z)/H]	1.000		
K _{zt} = [1+(K _c K _i)/K _h] ²	1.000		
K _{iz} = [z/33] ^(0.10)	1.146	K _{iz} ≤ 1.4	
t _{iz} = (t _i)(I)(K _{iz})(K _{zt}) ^(0.35)	1.146	in (w/ ice)	
C = (K _{zt} K _z K _e) ^{0.5} (V)(D)	192.603	(w/o ice)	
C = (K _{zt} K _z K _e) ^{0.5} (V _i)(D)	68.178	(w/ ice)	
C = (K _{zt} K _z K _e) ^{0.5} (V)(D)	51.134	(service)	
G _h =	1.00		
K _d =	0.95		
K _s =	1.00		
K _a =	0.90		
K _e = e ^{-0.0000362z_s}	1.00		
q _z = 0.00256K _z K _{zt} K _s K _e K _d V ²	41.47	psf (w/o ice)	
q _z = 0.00256K _z K _{zt} K _s K _e K _d V _i ²	5.20	psf (w/ ice)	
q _z = 0.00256K _z K _{zt} K _s K _e K _d V _s ²	2.92	psf (service)	
Position	1	x	1
		x	
		x	
		x	

Side

Manufacturer Model #	NOKIA AEUQ		
Length	29.5	in	
Width	17.7	in	
Depth	9.5	in	
Weight	99.21	lb	
Design Ice Thickness (t _i)	1	in	
Structure Type	B	(S, G, M, B)	
Structure Height (h)	112	ft	
Antenna Centerline (z)	129	ft	
Basic Wind Speed (V)	113	mph (w/o ice)	
Basic Wind Speed (V _i)	40	mph (w/ ice)	
Basic Wind Speed (V _s)	30	mph (service)	
Risk Category	II	(I, II, III, IV)	
Exposure Category	C	(B, C or D)	
Topographic Category	1	(1, 2, 3 or 4)	
Crest Height (H)	0	ft	
Shape	F	(R / F / S)	
Length / Width	3.105	(w/o ice)	
Length / Width	2.696	(w/ ice)	
C _a	1.227	(w/o ice)	
C _a	1.209	(w/ ice)	
C _a	1.227	(service)	
(EPA) _A	2.149	ft ² (w/o ice)	
(EPA) _A	2.832	ft ² (w/ ice)	
(EPA) _A	2.149	ft ² (service)	
F _A = q _z G _h (EPA) _A	89.113	lb (w/o ice)	
F _A = q _z G _h (EPA) _A	14.716	lb (w/ ice)	
F _A = q _z G _h (EPA) _A	6.281	lb (service)	
Ice Weight	73.091	lb	
Total Weight	172.301	lb (w/ ice)	
Equations			
K _z = 2.01[z/z _d] ^(2/α)	1.335	K _{zmin} ≤ K _z ≤ 2.01	
K _h = e ^[(7)(z)/H]	1.000		
K _{zt} = [1+(K _c K _i)/K _h] ²	1.000		
K _{iz} = [z/33] ^(0.10)	1.146	K _{iz} ≤ 1.4	
t _{iz} = (t _i)(I)(K _{iz})(K _{zt}) ^(0.35)	1.146	in (w/ ice)	
C = (K _{zt} K _z K _e) ^{0.5} (V)(D)	103.374	(w/o ice)	
C = (K _{zt} K _z K _e) ^{0.5} (V _i)(D)	36.593	(w/ ice)	
C = (K _{zt} K _z K _e) ^{0.5} (V)(D)	27.445	(service)	
G _h =	1.00		
K _d =	0.95		
K _s =	1.00		
K _a =	0.90		
K _e = e ^{-0.0000362z_s}	1.00		
q _z = 0.00256K _z K _{zt} K _s K _e K _d V ²	41.467	psf (w/o ice)	
q _z = 0.00256K _z K _{zt} K _s K _e K _d V _i ²	5.196	psf (w/ ice)	
q _z = 0.00256K _z K _{zt} K _s K _e K _d V _s ²	2.923	psf (service)	
Position	1	x	1
		x	
		x	
		x	



WIND/ICE/SERVICE LOADING
 ANTENNA MOUNTING SYSTEM
 ANSI/TIA-222-H

Project Number:	EP5TRFWL
Site Name:	Tulip Ave
Engineer:	H. Bedane
Date:	05/05/2022
Carrier:	AT&T
Reviewed By:	B. Bartlett

Input Data

Front

Manufacturer Model #	NOKIA AHLBA		
Length	28.7	in	
Width	15.35	in	
Depth	9.45	in	
Weight	101.4	lb	
Design Ice Thickness (t _i)	1	in	
Structure Type	B	(S, G, M, B)	
Structure Height (h)	112	ft	
Antenna Centerline (z)	129	ft	
Basic Wind Speed (V)	113	mph (w/o ice)	
Basic Wind Speed (V _i)	40	mph (w/ ice)	
Basic Wind Speed (V _s)	30	mph (service)	
Risk Category	II	(I, II, III, IV)	
Exposure Category	C	(B, C or D)	
Topographic Category	1	(1, 2, 3 or 4)	
Crest Height (H)	0	ft	
Shape	F	(R / F / S)	
Length / Width	1.870	(w/o ice)	
Length / Width	1.757	(w/ ice)	
C _a	1.200	(w/o ice)	
C _a	1.200	(w/ ice)	
C _a	1.200	(service)	
(EPA) _A	3.304	ft ² (w/o ice)	
(EPA) _A	4.101	ft ² (w/ ice)	
(EPA) _A	3.304	ft ² (service)	
F _A = q _z G _h (EPA) _A	137.011	lb (w/o ice)	
F _A = q _z G _h (EPA) _A	21.307	lb (w/ ice)	
F _A = q _z G _h (EPA) _A	9.657	lb (service)	
Ice Weight	64.201	lb	
Total Weight	165.601	lb (w/ ice)	
Equations			
K _z = 2.01[z/z _d] ^(2/α)	1.335	K _{zmin} ≤ K _z ≤ 2.01	
K _h = e ^[(7)(z)/H]	1.000		
K _{zt} = [1+(K _z K _h)/K _h] ²	1.000		
K _{iz} = [z/33] ^(0.10)	1.146	K _{iz} ≤ 1.4	
t _{iz} = (t _i)(I)(K _{iz})(K _{zt}) ^(0.35)	1.146	in (w/ ice)	
C = (K _{zt} K _z K _e) ^{0.5} (V)(D)	167.031	(w/o ice)	
C = (K _{zt} K _z K _e) ^{0.5} (V _i)(D)	59.126	(w/ ice)	
C = (K _{zt} K _z K _e) ^{0.5} (V)(D)	44.345	(service)	
G _h =	1.00		
K _d =	0.95		
K _s =	1.00		
K _a =	0.90		
K _e = e ^{-0.0000362z_s}	1.00		
q _z = 0.00256K _z K _{zt} K _s K _e K _d V ²	41.47	psf (w/o ice)	
q _z = 0.00256K _z K _{zt} K _s K _e K _d V _i ²	5.20	psf (w/ ice)	
q _z = 0.00256K _z K _{zt} K _s K _e K _d V _s ²	2.92	psf (service)	
Position		x	
		x	
		x	
		x	

Side

Manufacturer Model #	NOKIA AHLBA		
Length	28.7	in	
Width	15.35	in	
Depth	9.45	in	
Weight	101.4	lb	
Design Ice Thickness (t _i)	1	in	
Structure Type	B	(S, G, M, B)	
Structure Height (h)	112	ft	
Antenna Centerline (z)	129	ft	
Basic Wind Speed (V)	113	mph (w/o ice)	
Basic Wind Speed (V _i)	40	mph (w/ ice)	
Basic Wind Speed (V _s)	30	mph (service)	
Risk Category	II	(I, II, III, IV)	
Exposure Category	C	(B, C or D)	
Topographic Category	1	(1, 2, 3 or 4)	
Crest Height (H)	0	ft	
Shape	F	(R / F / S)	
Length / Width	3.037	(w/o ice)	
Length / Width	2.639	(w/ ice)	
C _a	1.224	(w/o ice)	
C _a	1.206	(w/ ice)	
C _a	1.224	(service)	
(EPA) _A	2.075	ft ² (w/o ice)	
(EPA) _A	2.743	ft ² (w/ ice)	
(EPA) _A	2.075	ft ² (service)	
F _A = q _z G _h (EPA) _A	86.027	lb (w/o ice)	
F _A = q _z G _h (EPA) _A	14.255	lb (w/ ice)	
F _A = q _z G _h (EPA) _A	6.063	lb (service)	
Ice Weight	64.201	lb	
Total Weight	165.601	lb (w/ ice)	
Equations			
K _z = 2.01[z/z _d] ^(2/α)	1.335	K _{zmin} ≤ K _z ≤ 2.01	
K _h = e ^[(7)(z)/H]	1.000		
K _{zt} = [1+(K _z K _h)/K _h] ²	1.000		
K _{iz} = [z/33] ^(0.10)	1.146	K _{iz} ≤ 1.4	
t _{iz} = (t _i)(I)(K _{iz})(K _{zt}) ^(0.35)	1.146	in (w/ ice)	
C = (K _{zt} K _z K _e) ^{0.5} (V)(D)	102.830	(w/o ice)	
C = (K _{zt} K _z K _e) ^{0.5} (V _i)(D)	36.400	(w/ ice)	
C = (K _{zt} K _z K _e) ^{0.5} (V)(D)	27.300	(service)	
G _h =	1.00		
K _d =	0.95		
K _s =	1.00		
K _a =	0.90		
K _e = e ^{-0.0000362z_s}	1.00		
q _z = 0.00256K _z K _{zt} K _s K _e K _d V ²	41.467	psf (w/o ice)	
q _z = 0.00256K _z K _{zt} K _s K _e K _d V _i ²	5.196	psf (w/ ice)	
q _z = 0.00256K _z K _{zt} K _s K _e K _d V _s ²	2.923	psf (service)	
Position		x	
		x	
		x	
		x	



WIND/ICE/SERVICE LOADING
 ANTENNA MOUNTING SYSTEM
 ANSI/TIA-222-H

Project Number:	EP5TRFWL
Site Name:	Tulip Ave
Engineer:	H. Bedane
Date:	05/05/2022
Carrier:	AT&T
Reviewed By:	B. Bartlett

Input Data

Front

Manufacturer Model #	NOKIA AHFIB		
Length	26.57	in	
Width	12.87	in	
Depth	6.5	in	
Weight	65	lb	
Design Ice Thickness (t _i)	1	in	
Structure Type	B	(S, G, M, B)	
Structure Height (h)	112	ft	
Antenna Centerline (z)	129	ft	
Basic Wind Speed (V)	113	mph (w/o ice)	
Basic Wind Speed (V _i)	40	mph (w/ ice)	
Basic Wind Speed (V _s)	30	mph (service)	
Risk Category	II	(I, II, III, IV)	
Exposure Category	C	(B, C or D)	
Topographic Category	1	(1, 2, 3 or 4)	
Crest Height (H)	0	ft	
Shape	F	(R / F / S)	
Length / Width	2.064	(w/o ice)	
Length / Width	1.904	(w/ ice)	
C _a	1.200	(w/o ice)	
C _a	1.200	(w/ ice)	
C _a	1.200	(service)	
(EPA) _A	2.565	ft ² (w/o ice)	
(EPA) _A	3.282	ft ² (w/ ice)	
(EPA) _A	2.565	ft ² (service)	
F _A = q _z G _h (EPA) _A	106.350	lb (w/o ice)	
F _A = q _z G _h (EPA) _A	17.054	lb (w/ ice)	
F _A = q _z G _h (EPA) _A	7.496	lb (service)	
Ice Weight	48.253	lb	
Total Weight	113.253	lb (w/ ice)	
Equations			
K _z = 2.01[z/z _d] ^(2/α)	1.335	K _{zmin} ≤ K _z ≤ 2.01	
K _h = e ^[(7)(z)/H]	1.000		
K _{zt} = [1+(K _c K _i)/K _h] ²	1.000		
K _{iz} = [z/33] ^(0.10)	1.146	K _{iz} ≤ 1.4	
t _{iz} = (t _i)(I)(K _{iz})(K _{zt}) ^(0.35)	1.146	in (w/ ice)	
C = (K _{zt} K _z K _e) ^{0.5} (V)(D)	140.045	(w/o ice)	
C = (K _{zt} K _z K _e) ^{0.5} (V _i)(D)	49.574	(w/ ice)	
C = (K _{zt} K _z K _e) ^{0.5} (V)(D)	37.180	(service)	
G _h =	1.00		
K _d =	0.95		
K _s =	1.00		
K _a =	0.90		
K _e = e ^{-0.0000362z_s}	1.00		
q _z = 0.00256K _z K _{zt} K _s K _e K _d V ²	41.47	psf (w/o ice)	
q _z = 0.00256K _z K _{zt} K _s K _e K _d V _i ²	5.20	psf (w/ ice)	
q _z = 0.00256K _z K _{zt} K _s K _e K _d V _s ²	2.92	psf (service)	
Position		x	
		x	
		x	
		x	

Side

Manufacturer Model #	NOKIA AHFIB		
Length	26.57	in	
Width	12.87	in	
Depth	6.5	in	
Weight	65	lb	
Design Ice Thickness (t _i)	1	in	
Structure Type	B	(S, G, M, B)	
Structure Height (h)	112	ft	
Antenna Centerline (z)	129	ft	
Basic Wind Speed (V)	113	mph (w/o ice)	
Basic Wind Speed (V _i)	40	mph (w/ ice)	
Basic Wind Speed (V _s)	30	mph (service)	
Risk Category	II	(I, II, III, IV)	
Exposure Category	C	(B, C or D)	
Topographic Category	1	(1, 2, 3 or 4)	
Crest Height (H)	0	ft	
Shape	F	(R / F / S)	
Length / Width	4.088	(w/o ice)	
Length / Width	3.283	(w/ ice)	
C _a	1.271	(w/o ice)	
C _a	1.235	(w/ ice)	
C _a	1.271	(service)	
(EPA) _A	1.371	ft ² (w/o ice)	
(EPA) _A	1.958	ft ² (w/ ice)	
(EPA) _A	1.371	ft ² (service)	
F _A = q _z G _h (EPA) _A	56.870	lb (w/o ice)	
F _A = q _z G _h (EPA) _A	10.176	lb (w/ ice)	
F _A = q _z G _h (EPA) _A	4.008	lb (service)	
Ice Weight	48.253	lb	
Total Weight	113.253	lb (w/ ice)	
Equations			
K _z = 2.01[z/z _d] ^(2/α)	1.335	K _{zmin} ≤ K _z ≤ 2.01	
K _h = e ^[(7)(z)/H]	1.000		
K _{zt} = [1+(K _c K _i)/K _h] ²	1.000		
K _{iz} = [z/33] ^(0.10)	1.146	K _{iz} ≤ 1.4	
t _{iz} = (t _i)(I)(K _{iz})(K _{zt}) ^(0.35)	1.146	in (w/ ice)	
C = (K _{zt} K _z K _e) ^{0.5} (V)(D)	70.730	(w/o ice)	
C = (K _{zt} K _z K _e) ^{0.5} (V _i)(D)	25.037	(w/ ice)	
C = (K _{zt} K _z K _e) ^{0.5} (V)(D)	18.778	(service)	
G _h =	1.00		
K _d =	0.95		
K _s =	1.00		
K _a =	0.90		
K _e = e ^{-0.0000362z_s}	1.00		
q _z = 0.00256K _z K _{zt} K _s K _e K _d V ²	41.467	psf (w/o ice)	
q _z = 0.00256K _z K _{zt} K _s K _e K _d V _i ²	5.196	psf (w/ ice)	
q _z = 0.00256K _z K _{zt} K _s K _e K _d V _s ²	2.923	psf (service)	
Position		x	
		x	
		x	
		x	



WIND/ICE/SERVICE LOADING
 ANTENNA MOUNTING SYSTEM
 ANSI/TIA-222-H

Project Number:	EP5TRFWL
Site Name:	Tulip Ave
Engineer:	H. Bedane
Date:	05/05/2022
Carrier:	AT&T
Reviewed By:	B. Bartlett

Input Data

Front

Manufacturer Model #	ALCATEL LUCENT RRH4X25-WCS-4R		
Length	31.5	in	
Width	11.8	in	
Depth	8.7	in	
Weight	70	lb	
Design Ice Thickness (t _i)	1	in	
Structure Type	B	(S, G, M, B)	
Structure Height (h)	112	ft	
Antenna Centerline (z)	129	ft	
Basic Wind Speed (V)	113	mph (w/o ice)	
Basic Wind Speed (V _i)	40	mph (w/ ice)	
Basic Wind Speed (V _s)	30	mph (service)	
Risk Category	II	(I, II, III, IV)	
Exposure Category	C	(B, C or D)	
Topographic Category	1	(1, 2, 3 or 4)	
Crest Height (H)	0	ft	
Shape	F	(R / F / S)	
Length / Width	2.669	(w/o ice)	
Length / Width	2.398	(w/ ice)	
C _a	1.208	(w/o ice)	
C _a	1.200	(w/ ice)	
C _a	1.208	(service)	
(EPA) _A	2.805	ft ² (w/o ice)	
(EPA) _A	3.572	ft ² (w/ ice)	
(EPA) _A	2.805	ft ² (service)	
F _A = q _z G _h (EPA) _A	116.326	lb (w/o ice)	
F _A = q _z G _h (EPA) _A	18.558	lb (w/ ice)	
F _A = q _z G _h (EPA) _A	8.199	lb (service)	
Ice Weight	58.096	lb	
Total Weight	128.096	lb (w/ ice)	
Equations			
K _z = 2.01[z/z _d] ^(2/α)	1.335	K _{zmin} ≤ K _z ≤ 2.01	
K _h = e ^[(7)(z)/H]	1.000		
K _{zt} = [1+(K _c K _i)/K _h] ²	1.000		
K _{iz} = [z/33] ^(0.10)	1.146	K _{iz} ≤ 1.4	
t _{iz} = (t _i)(I)(K _{iz})(K _{zt}) ^(0.35)	1.146	in (w/ ice)	
C = (K _{zt} K _z K _e) ^{0.5} (V)(D)	128.402	(w/o ice)	
C = (K _{zt} K _z K _e) ^{0.5} (V _i)(D)	45.452	(w/ ice)	
C = (K _{zt} K _z K _e) ^{0.5} (V)(D)	34.089	(service)	
G _h =	1.00		
K _d =	0.95		
K _s =	1.00		
K _a =	0.90		
K _e = e ^{-0.0000362z_s}	1.00		
q _z = 0.00256K _z K _{zt} K _s K _e K _d V ²	41.47	psf (w/o ice)	
q _z = 0.00256K _z K _{zt} K _s K _e K _d V _i ²	5.20	psf (w/ ice)	
q _z = 0.00256K _z K _{zt} K _s K _e K _d V _s ²	2.92	psf (service)	
Position		x	
		x	
		x	
		x	

Side

Manufacturer Model #	ALCATEL LUCENT RRH4X25-WCS-4R		
Length	31.5	in	
Width	11.8	in	
Depth	8.7	in	
Weight	70	lb	
Design Ice Thickness (t _i)	1	in	
Structure Type	B	(S, G, M, B)	
Structure Height (h)	112	ft	
Antenna Centerline (z)	129	ft	
Basic Wind Speed (V)	113	mph (w/o ice)	
Basic Wind Speed (V _i)	40	mph (w/ ice)	
Basic Wind Speed (V _s)	30	mph (service)	
Risk Category	II	(I, II, III, IV)	
Exposure Category	C	(B, C or D)	
Topographic Category	1	(1, 2, 3 or 4)	
Crest Height (H)	0	ft	
Shape	F	(R / F / S)	
Length / Width	3.621	(w/o ice)	
Length / Width	3.074	(w/ ice)	
C _a	1.250	(w/o ice)	
C _a	1.226	(w/ ice)	
C _a	1.250	(service)	
(EPA) _A	2.141	ft ² (w/o ice)	
(EPA) _A	2.845	ft ² (w/ ice)	
(EPA) _A	2.141	ft ² (service)	
F _A = q _z G _h (EPA) _A	88.768	lb (w/o ice)	
F _A = q _z G _h (EPA) _A	14.783	lb (w/ ice)	
F _A = q _z G _h (EPA) _A	6.257	lb (service)	
Ice Weight	58.096	lb	
Total Weight	128.096	lb (w/ ice)	
Equations			
K _z = 2.01[z/z _d] ^(2/α)	1.335	K _{zmin} ≤ K _z ≤ 2.01	
K _h = e ^[(7)(z)/H]	1.000		
K _{zt} = [1+(K _c K _i)/K _h] ²	1.000		
K _{iz} = [z/33] ^(0.10)	1.146	K _{iz} ≤ 1.4	
t _{iz} = (t _i)(I)(K _{iz})(K _{zt}) ^(0.35)	1.146	in (w/ ice)	
C = (K _{zt} K _z K _e) ^{0.5} (V)(D)	94.669	(w/o ice)	
C = (K _{zt} K _z K _e) ^{0.5} (V _i)(D)	33.511	(w/ ice)	
C = (K _{zt} K _z K _e) ^{0.5} (V)(D)	25.133	(service)	
G _h =	1.00		
K _d =	0.95		
K _s =	1.00		
K _a =	0.90		
K _e = e ^{-0.0000362z_s}	1.00		
q _z = 0.00256K _z K _{zt} K _s K _e K _d V ²	41.467	psf (w/o ice)	
q _z = 0.00256K _z K _{zt} K _s K _e K _d V _i ²	5.196	psf (w/ ice)	
q _z = 0.00256K _z K _{zt} K _s K _e K _d V _s ²	2.923	psf (service)	
Position		x	
		x	
		x	
		x	



WIND/ICE/SERVICE LOADING
 ANTENNA MOUNTING SYSTEM
 ANSI/TIA-222-H

Project Number:	EP5TRFWL
Site Name:	Tulip Ave
Engineer:	H. Bedane
Date:	05/05/2022
Carrier:	AT&T
Reviewed By:	B. Bartlett

Input Data

Front

Manufacturer Model #	NOKIA AHBCB		
Length	22.05	in	
Width	12.13	in	
Depth	7.44	in	
Weight	85.98	lb	
Design Ice Thickness (t _i)	1	in	
Structure Type	B	(S, G, M, B)	
Structure Height (h)	112	ft	
Antenna Centerline (z)	129	ft	
Basic Wind Speed (V)	113	mph (w/o ice)	
Basic Wind Speed (V _i)	40	mph (w/ ice)	
Basic Wind Speed (V _s)	30	mph (service)	
Risk Category	II	(I, II, III, IV)	
Exposure Category	C	(B, C or D)	
Topographic Category	1	(1, 2, 3 or 4)	
Crest Height (H)	0	ft	
Shape	F	(R / F / S)	
Length / Width	1.818	(w/o ice)	
Length / Width	1.688	(w/ ice)	
C _a	1.200	(w/o ice)	
C _a	1.200	(w/ ice)	
C _a	1.200	(service)	
(EPA) _A	2.006	ft ² (w/o ice)	
(EPA) _A	2.633	ft ² (w/ ice)	
(EPA) _A	2.006	ft ² (service)	
F _A = q _z G _h (EPA) _A	83.183	lb (w/o ice)	
F _A = q _z G _h (EPA) _A	13.681	lb (w/ ice)	
F _A = q _z G _h (EPA) _A	5.863	lb (service)	
Ice Weight	39.560	lb	
Total Weight	125.540	lb (w/ ice)	
Equations			
K _z = 2.01[z/z _d] ^(2/α)	1.335	K _{zmin} ≤ K _z ≤ 2.01	
K _h = e ^[(7)(z)/H]	1.000		
K _{zt} = [1+(K _c K _i)/K _h] ²	1.000		
K _{iz} = [z/33] ^(0.10)	1.146	K _{iz} ≤ 1.4	
t _{iz} = (t _i)(I)(K _{iz})(K _{zt}) ^(0.35)	1.146	in (w/ ice)	
C = (K _{zt} K _z K _e) ^{0.5} (V)(D)	131.993	(w/o ice)	
C = (K _{zt} K _z K _e) ^{0.5} (V _i)(D)	46.723	(w/ ice)	
C = (K _{zt} K _z K _e) ^{0.5} (V)(D)	35.042	(service)	
G _h =	1.00		
K _d =	0.95		
K _s =	1.00		
K _a =	0.90		
K _e = e ^{-0.0000362z_s}	1.00		
q _z = 0.00256K _z K _{zt} K _s K _e K _d V ²	41.47	psf (w/o ice)	
q _z = 0.00256K _z K _{zt} K _s K _e K _d V _i ²	5.20	psf (w/ ice)	
q _z = 0.00256K _z K _{zt} K _s K _e K _d V _s ²	2.92	psf (service)	
Position		x	
		x	
		x	
		x	

Side

Manufacturer Model #	NOKIA AHBCB		
Length	22.05	in	
Width	12.13	in	
Depth	7.44	in	
Weight	85.98	lb	
Design Ice Thickness (t _i)	1	in	
Structure Type	B	(S, G, M, B)	
Structure Height (h)	112	ft	
Antenna Centerline (z)	129	ft	
Basic Wind Speed (V)	113	mph (w/o ice)	
Basic Wind Speed (V _i)	40	mph (w/ ice)	
Basic Wind Speed (V _s)	30	mph (service)	
Risk Category	II	(I, II, III, IV)	
Exposure Category	C	(B, C or D)	
Topographic Category	1	(1, 2, 3 or 4)	
Crest Height (H)	0	ft	
Shape	F	(R / F / S)	
Length / Width	2.964	(w/o ice)	
Length / Width	2.501	(w/ ice)	
C _a	1.221	(w/o ice)	
C _a	1.200	(w/ ice)	
C _a	1.221	(service)	
(EPA) _A	1.252	ft ² (w/o ice)	
(EPA) _A	1.777	ft ² (w/ ice)	
(EPA) _A	1.252	ft ² (service)	
F _A = q _z G _h (EPA) _A	51.897	lb (w/o ice)	
F _A = q _z G _h (EPA) _A	9.232	lb (w/ ice)	
F _A = q _z G _h (EPA) _A	3.658	lb (service)	
Ice Weight	39.560	lb	
Total Weight	125.540	lb (w/ ice)	
Equations			
K _z = 2.01[z/z _d] ^(2/α)	1.335	K _{zmin} ≤ K _z ≤ 2.01	
K _h = e ^[(7)(z)/H]	1.000		
K _{zt} = [1+(K _c K _i)/K _h] ²	1.000		
K _{iz} = [z/33] ^(0.10)	1.146	K _{iz} ≤ 1.4	
t _{iz} = (t _i)(I)(K _{iz})(K _{zt}) ^(0.35)	1.146	in (w/ ice)	
C = (K _{zt} K _z K _e) ^{0.5} (V)(D)	80.959	(w/o ice)	
C = (K _{zt} K _z K _e) ^{0.5} (V _i)(D)	28.658	(w/ ice)	
C = (K _{zt} K _z K _e) ^{0.5} (V)(D)	21.493	(service)	
G _h =	1.00		
K _d =	0.95		
K _s =	1.00		
K _a =	0.90		
K _e = e ^{-0.0000362z_s}	1.00		
q _z = 0.00256K _z K _{zt} K _s K _e K _d V ²	41.467	psf (w/o ice)	
q _z = 0.00256K _z K _{zt} K _s K _e K _d V _i ²	5.196	psf (w/ ice)	
q _z = 0.00256K _z K _{zt} K _s K _e K _d V _s ²	2.923	psf (service)	
Position		x	
		x	
		x	
		x	



WIND/ICE/SERVICE LOADING
 ANTENNA MOUNTING SYSTEM
 ANSI/TIA-222-H

Project Number:	EP5TRFWL
Site Name:	Tulip Ave
Engineer:	H. Bedane
Date:	05/05/2022
Carrier:	AT&T
Reviewed By:	B. Bartlett

Input Data

Front

Manufacturer		RAYCAP	
Model #		DC9-48-60-24-8C-EV	
Length	31.41	in	
Width	10.24	in	
Depth	18.28	in	
Weight	26.2	lb	
Design Ice Thickness (t _i)	1	in	
Structure Type	B	(S, G, M, B)	
Structure Height (h)	112	ft	
Antenna Centerline (z)	129	ft	
Basic Wind Speed (V)	113	mph (w/o ice)	
Basic Wind Speed (V _i)	40	mph (w/ ice)	
Basic Wind Speed (V _s)	30	mph (service)	
Risk Category	II	(I, II, III, IV)	
Exposure Category	C	(B, C or D)	
Topographic Category	1	(1, 2, 3 or 4)	
Crest Height (H)	0	ft	
Shape	F	(R / F / S)	
Length / Width	3.067	(w/o ice)	
Length / Width	2.689	(w/ ice)	
C _a	1.225	(w/o ice)	
C _a	1.208	(w/ ice)	
C _a	1.225	(service)	
(EPA) _A	2.463	ft ² (w/o ice)	
(EPA) _A	3.190	ft ² (w/ ice)	
(EPA) _A	2.463	ft ² (service)	
F _A = q _z G _h (EPA) _A	102.133	lb (w/o ice)	
F _A = q _z G _h (EPA) _A	16.575	lb (w/ ice)	
F _A = q _z G _h (EPA) _A	7.199	lb (service)	
Ice Weight	80.991	lb	
Total Weight	107.191	lb (w/ ice)	
Equations			
K _z = 2.01[z/z _d] ^(2/α)	1.335	K _{zmin} ≤ K _z ≤ 2.01	
K _h = e ^[(7)(z)/H]	1.000		
K _{zt} = [1+(K _z K _h)/K _h] ²	1.000		
K _{iz} = [z/33] ^(0.10)	1.146	K _{iz} ≤ 1.4	
t _{iz} = (t _i)(I)(K _{iz})(K _{zt}) ^(0.35)	1.146	in (w/ ice)	
C = (K _{zt} K _z K _e) ^{0.5} (V)(D)	111.427	(w/o ice)	
C = (K _{zt} K _z K _e) ^{0.5} (V _i)(D)	39.443	(w/ ice)	
C = (K _{zt} K _z K _e) ^{0.5} (V)(D)	29.582	(service)	
G _h =	1.00		
K _d =	0.95		
K _s =	1.00		
K _a =	0.90		
K _e = e ^{-0.0000362z_s}	1.00		
q _z = 0.00256K _z K _{zt} K _s K _e K _d V ²	41.47	psf (w/o ice)	
q _z = 0.00256K _z K _{zt} K _s K _e K _d V _i ²	5.20	psf (w/ ice)	
q _z = 0.00256K _z K _{zt} K _s K _e K _d V _s ²	2.92	psf (service)	
Position		x	
		x	
		x	
		x	

Side

Manufacturer		RAYCAP	
Model #		DC9-48-60-24-8C-EV	
Length	31.41	in	
Width	10.24	in	
Depth	18.28	in	
Weight	26.2	lb	
Design Ice Thickness (t _i)	1	in	
Structure Type	B	(S, G, M, B)	
Structure Height (h)	112	ft	
Antenna Centerline (z)	129	ft	
Basic Wind Speed (V)	113	mph (w/o ice)	
Basic Wind Speed (V _i)	40	mph (w/ ice)	
Basic Wind Speed (V _s)	30	mph (service)	
Risk Category	II	(I, II, III, IV)	
Exposure Category	C	(B, C or D)	
Topographic Category	1	(1, 2, 3 or 4)	
Crest Height (H)	0	ft	
Shape	F	(R / F / S)	
Length / Width	1.718	(w/o ice)	
Length / Width	1.638	(w/ ice)	
C _a	1.200	(w/o ice)	
C _a	1.200	(w/ ice)	
C _a	1.200	(service)	
(EPA) _A	4.306	ft ² (w/o ice)	
(EPA) _A	5.200	ft ² (w/ ice)	
(EPA) _A	4.306	ft ² (service)	
F _A = q _z G _h (EPA) _A	178.571	lb (w/o ice)	
F _A = q _z G _h (EPA) _A	27.019	lb (w/ ice)	
F _A = q _z G _h (EPA) _A	12.586	lb (service)	
Ice Weight	80.991	lb	
Total Weight	107.191	lb (w/ ice)	
Equations			
K _z = 2.01[z/z _d] ^(2/α)	1.335	K _{zmin} ≤ K _z ≤ 2.01	
K _h = e ^[(7)(z)/H]	1.000		
K _{zt} = [1+(K _z K _h)/K _h] ²	1.000		
K _{iz} = [z/33] ^(0.10)	1.146	K _{iz} ≤ 1.4	
t _{iz} = (t _i)(I)(K _{iz})(K _{zt}) ^(0.35)	1.146	in (w/ ice)	
C = (K _{zt} K _z K _e) ^{0.5} (V)(D)	198.914	(w/o ice)	
C = (K _{zt} K _z K _e) ^{0.5} (V _i)(D)	70.412	(w/ ice)	
C = (K _{zt} K _z K _e) ^{0.5} (V)(D)	52.809	(service)	
G _h =	1.00		
K _d =	0.95		
K _s =	1.00		
K _a =	0.90		
K _e = e ^{-0.0000362z_s}	1.00		
q _z = 0.00256K _z K _{zt} K _s K _e K _d V ²	41.467	psf (w/o ice)	
q _z = 0.00256K _z K _{zt} K _s K _e K _d V _i ²	5.196	psf (w/ ice)	
q _z = 0.00256K _z K _{zt} K _s K _e K _d V _s ²	2.923	psf (service)	
Position		x	
		x	
		x	
		x	



WIND/ICE/SERVICE LOADING
ANTENNA MOUNTING SYSTEM

ANSI/TIA-222-H

Project Number:	EP5TRFWL
Site Name:	Tulip Ave
Engineer:	H. Bedane
Date:	05/05/2022
Carrier:	AT&T
Reviewed By:	B. Bartlett

Input Data

Front

Member Size	Antenna Pipe A Pipe 2.0	
Length	96	in
Width	2.38	in
Depth	2.38	in
Weight	0	lb/ft
Design Ice Thickness (t _i)	1	in
Structure Type	B	(S, G, M, B)
Structure Height (h)	112	ft
Antenna Centerline (z)	129	ft
Basic Wind Speed (V)	113	mph (w/o ice)
Basic Wind Speed (V _i)	40	mph (w/ ice)
Basic Wind Speed (V _s)	30	mph (service)
Risk Category	II	(I, II, III, IV)
Exposure Category	C	(B, C or D)
Topographic Category	1	(1, 2, 3 or 4)
Crest Height (H)	0	ft
Shape	R	(R / F / S)
Length / Width	40.336	(w/o ice)
Length / Width	21.038	(w/ ice)
C _a	1.200	(w/o ice)
C _a	1.112	(w/ ice)
C _a	1.200	(service)
(EPA) _A	1.714	ft ² (w/o ice)
(EPA) _A	3.192	ft ² (w/ ice)
(EPA) _A	1.714	ft ² (service)
F _A = q _z G _h (EPA) _A	0.740	lb/in (w/o ice)
F _A = q _z G _h (EPA) _A	0.173	lb/in (w/ ice)
F _A = q _z G _h (EPA) _A	0.052	lb/in (service)
Ice Weight	0.526	lb/in
Weight	0.526	lb/in (w/ ice)
Equations		
K _z = 2.01[z/z _q] ^(2/α)	1.335	K _{zmin} ≤ K _z ≤ 2.01
K _h = e ^(-0.7z/H)	1.000	
K _{zt} = [1 + (K _c K _i)/K _h] ²	1.000	
K _{iz} = [z/33] ^(0.10)	1.146	K _{iz} ≤ 1.4
t _{iz} = (t _i)(I)(K _{iz})(K _{zt}) ^(0.35)	1.146	in (w/ ice)
C = (K _{zt} K _z K _e) ^{0.5} (V)(D)	25.898	(w/o ice)
C = (K _{zt} K _z K _e) ^{0.5} (V _i)(D)	9.167	(w/ ice)
C = (K _{zt} K _z K _e) ^{0.5} (V _s)(D)	6.876	(service)
G _h =	1.00	
K _d =	0.95	
K _s =	1.00	
K _a =	0.90	
K _e = e ^{-0.0000362z}	1.00	
q _z = 0.00256K _z K _{zt} K _s K _e K _d V ²	41.47	psf (w/o ice)
q _z = 0.00256K _z K _{zt} K _s K _e K _d V _i ²	5.20	psf (w/ ice)
q _z = 0.00256K _z K _{zt} K _s K _e K _d V _s ²	2.92	psf (service)
Quantity	6	(18 max)

Side

Member Size	Antenna Pipe A Pipe 2.0	
Length	96	in
Width	2.38	in
Depth	2.38	in
Weight	0	lb/ft
Design Ice Thickness (t _i)	1	in
Structure Type	B	(S, G, M, B)
Structure Height (h)	112	ft
Antenna Centerline (z)	129	ft
Basic Wind Speed (V)	113	mph (w/o ice)
Basic Wind Speed (V _i)	40	mph (w/ ice)
Basic Wind Speed (V _s)	30	mph (service)
Risk Category	II	(I, II, III, IV)
Exposure Category	C	(B, C or D)
Topographic Category	1	(1, 2, 3 or 4)
Crest Height (H)	0	ft
Shape	R	(R / F / S)
Length / Width	40.336	(w/o ice)
Length / Width	21.038	(w/ ice)
C _a	1.200	(w/o ice)
C _a	1.112	(w/ ice)
C _a	1.200	(service)
(EPA) _A	1.714	ft ² (w/o ice)
(EPA) _A	3.192	ft ² (w/ ice)
(EPA) _A	1.714	ft ² (service)
F _A = q _z G _h (EPA) _A	0.740	lb/in (w/o ice)
F _A = q _z G _h (EPA) _A	0.173	lb/in (w/ ice)
F _A = q _z G _h (EPA) _A	0.052	lb/in (service)
Ice Weight	0.526	lb/in
Weight	0.526	lb/in (w/ ice)
Equations		
K _z = 2.01[z/z _q] ^(2/α)	1.335	K _{zmin} ≤ K _z ≤ 2.01
K _h = e ^(-0.7z/H)	1.000	
K _{zt} = [1 + (K _c K _i)/K _h] ²	1.000	
K _{iz} = [z/33] ^(0.10)	1.146	K _{iz} ≤ 1.4
t _{iz} = (t _i)(I)(K _{iz})(K _{zt}) ^(0.35)	1.146	in (w/ ice)
C = (K _{zt} K _z K _e) ^{0.5} (V)(D)	25.898	(w/o ice)
C = (K _{zt} K _z K _e) ^{0.5} (V _i)(D)	9.167	(w/ ice)
C = (K _{zt} K _z K _e) ^{0.5} (V _s)(D)	6.876	(service)
G _h =	1.00	
K _d =	0.95	
K _s =	1.00	
K _a =	0.90	
K _e = e ^{-0.0000362z}	1.00	
q _z = 0.00256K _z K _{zt} K _s K _e K _d V ²	41.467	psf (w/o ice)
q _z = 0.00256K _z K _{zt} K _s K _e K _d V _i ²	5.196	psf (w/ ice)
q _z = 0.00256K _z K _{zt} K _s K _e K _d V _s ²	2.923	psf (service)
Quantity	6	(18 max)



**WIND/ICE/SERVICE LOADING
ANTENNA MOUNTING SYSTEM**

ANSI/TIA-222-H

Project Number:	EP5TRFWL
Site Name:	Tulip Ave
Engineer:	H. Bedane
Date:	05/05/2022
Carrier:	AT&T
Reviewed By:	B. Bartlett

Input Data

Front

Member Size	Antenna Pipe B Pipe 3.0	
Length	120	in
Width	3.5	in
Depth	3.5	in
Weight	0	lb/ft
Design Ice Thickness (t _i)	1	in
Structure Type	B	(S, G, M, B)
Structure Height (h)	112	ft
Antenna Centerline (z)	129	ft
Basic Wind Speed (V)	113	mph (w/o ice)
Basic Wind Speed (V _i)	40	mph (w/ ice)
Basic Wind Speed (V _s)	30	mph (service)
Risk Category	II	(I, II, III, IV)
Exposure Category	C	(B, C or D)
Topographic Category	1	(1, 2, 3 or 4)
Crest Height (H)	0	ft
Shape	R	(R / F / S)
Length / Width	34.286	(w/o ice)
Length / Width	21.114	(w/ ice)
C _a	1.200	(w/o ice)
C _a	1.114	(w/ ice)
C _a	1.200	(service)
(EPA) _A	3.150	ft ² (w/o ice)
(EPA) _A	4.930	ft ² (w/ ice)
(EPA) _A	3.150	ft ² (service)
F _A = q _z G _h (EPA) _A	1.089	lb/in (w/o ice)
F _A = q _z G _h (EPA) _A	0.213	lb/in (w/ ice)
F _A = q _z G _h (EPA) _A	0.077	lb/in (service)
Ice Weight	0.711	lb/in
Weight	0.711	lb/in (w/ ice)
<i>Equations</i>		
$K_z = 2.01 [z/z_q]^{(2/\alpha)}$	1.335	$K_{zmin} \leq K_z \leq 2.01$
$K_h = e^{(0.2z)/H}$	1.000	
$K_{zt} = [1 + (K_c K_t) / K_h]^2$	1.000	
$K_{iz} = [z/33]^{(0.10)}$	1.146	$K_{iz} \leq 1.4$
$t_{iz} = (t_i)(I)(K_{iz})(K_{zt})^{(0.35)}$	1.146	in (w/ ice)
$C = (K_{zt} K_z K_e)^{0.5} (V)(D)$	38.085	(w/o ice)
$C = (K_{zt} K_z K_e)^{0.5} (V_i)(D)$	13.482	(w/ ice)
$C = (K_{zt} K_z K_e)^{0.5} (V_s)(D)$	10.111	(service)
G _h =	1.00	
K _d =	0.95	
K _s =	1.00	
K _a =	0.90	
$K_e = e^{-0.0000362z}$	1.00	
$q_z = 0.00256 K_z K_{zt} K_s K_e K_d V^2$	41.47	psf (w/o ice)
$q_z = 0.00256 K_z K_{zt} K_e K_d V_i^2$	5.20	psf (w/ ice)
$q_z = 0.00256 K_z K_{zt} K_s K_e K_d V_s^2$	2.92	psf (service)
Quantity	3	(18 max)

Side

Member Size	Antenna Pipe B Pipe 3.0	
Length	120	in
Width	3.5	in
Depth	3.5	in
Weight	0	lb/ft
Design Ice Thickness (t _i)	1	in
Structure Type	B	(S, G, M, B)
Structure Height (h)	112	ft
Antenna Centerline (z)	129	ft
Basic Wind Speed (V)	113	mph (w/o ice)
Basic Wind Speed (V _i)	40	mph (w/ ice)
Basic Wind Speed (V _s)	30	mph (service)
Risk Category	II	(I, II, III, IV)
Exposure Category	C	(B, C or D)
Topographic Category	1	(1, 2, 3 or 4)
Crest Height (H)	0	ft
Shape	R	(R / F / S)
Length / Width	34.286	(w/o ice)
Length / Width	21.114	(w/ ice)
C _a	1.200	(w/o ice)
C _a	1.114	(w/ ice)
C _a	1.200	(service)
(EPA) _A	3.150	ft ² (w/o ice)
(EPA) _A	4.930	ft ² (w/ ice)
(EPA) _A	3.150	ft ² (service)
F _A = q _z G _h (EPA) _A	1.089	lb/in (w/o ice)
F _A = q _z G _h (EPA) _A	0.213	lb/in (w/ ice)
F _A = q _z G _h (EPA) _A	0.077	lb/in (service)
Ice Weight	0.711	lb/in
Weight	0.711	lb/in (w/ ice)
<i>Equations</i>		
$K_z = 2.01 [z/z_q]^{(2/\alpha)}$	1.335	$K_{zmin} \leq K_z \leq 2.01$
$K_h = e^{(0.2z)/H}$	1.000	
$K_{zt} = [1 + (K_c K_t) / K_h]^2$	1.000	
$K_{iz} = [z/33]^{(0.10)}$	1.146	$K_{iz} \leq 1.4$
$t_{iz} = (t_i)(I)(K_{iz})(K_{zt})^{(0.35)}$	1.146	in (w/ ice)
$C = (K_{zt} K_z K_e)^{0.5} (V)(D)$	38.085	(w/o ice)
$C = (K_{zt} K_z K_e)^{0.5} (V_i)(D)$	13.482	(w/ ice)
$C = (K_{zt} K_z K_e)^{0.5} (V_s)(D)$	10.111	(service)
G _h =	1.00	
K _d =	0.95	
K _s =	1.00	
K _a =	0.90	
$K_e = e^{-0.0000362z}$	1.00	
$q_z = 0.00256 K_z K_{zt} K_s K_e K_d V^2$	41.467	psf (w/o ice)
$q_z = 0.00256 K_z K_{zt} K_e K_d V_i^2$	5.196	psf (w/ ice)
$q_z = 0.00256 K_z K_{zt} K_s K_e K_d V_s^2$	2.923	psf (service)
Quantity	3	(18 max)

MODEL	QUANTITY	DEAD LOAD	DEAD LOAD (ICE)	WIND LOAD (NO ICE) FRONT	WIND LOAD (NO ICE) SIDE	WIND LOAD (ICE) FRONT	WIND LOAD (ICE) SIDE	WIND LOAD (SERVICE) FRONT	WIND LOAD (SERVICE) SIDE	SEISMIC LOAD (VERTICAL)	SEISMIC LOAD (LATERAL) FRONT	SEISMIC LOAD (LATERAL) SIDE
AEQK	1	-99.21	-73.3	162.7	89.5	24.8	14.8	11.5	6.3	0.0	0.0	0.0
AEQU	1	-99.21	-73.1	162.4	89.1	24.8	14.7	11.4	6.3	0.0	0.0	0.0
NNHH-65A-R4	1	-67.2	-143.0	339.7	156.2	49.2	25.2	23.9	11.0	0.0	0.0	0.0
NNHH-65A-R4	1	-67.2	-143.0	339.7	156.2	49.2	25.2	23.9	11.0	0.0	0.0	0.0

TYPE	QUANTITY	MEMBER	DEAD LOAD (ICE)	WIND LOAD (NO ICE) FRONT	WIND LOAD (NO ICE) SIDE	WIND LOAD (ICE) FRONT	WIND LOAD (ICE) SIDE	WIND LOAD (SERVICE) FRONT	WIND LOAD (SERVICE) SIDE
Antenna Pipe A	1	1	-0.526	0.740	0.740	0.173	0.173	0.052	0.052
Antenna Pipe A	1	2	-0.526	0.740	0.740	0.173	0.173	0.052	0.052
Antenna Pipe A	1	3	-0.526	0.740	0.740	0.173	0.173	0.052	0.052
Antenna Pipe A	1	4	-0.526	0.740	0.740	0.173	0.173	0.052	0.052
Antenna Pipe A	1	5	-0.526	0.740	0.740	0.173	0.173	0.052	0.052
Antenna Pipe A	1	6	-0.526	0.740	0.740	0.173	0.173	0.052	0.052
Antenna Pipe B	1	1	-0.711	1.089	1.089	0.213	0.213	0.077	0.077
Antenna Pipe B	1	2	-0.711	1.089	1.089	0.213	0.213	0.077	0.077
Antenna Pipe B	1	3	-0.711	1.089	1.089	0.213	0.213	0.077	0.077

ASCE 7 Hazards Report

Address:
No Address at This Location

Standard: ASCE/SEI 7-16
Risk Category: II
Soil Class: D - Default (see Section 11.4.3)

Elevation: 282.09 ft (NAVD 88)
Latitude: 38.974747
Longitude: -77.010437

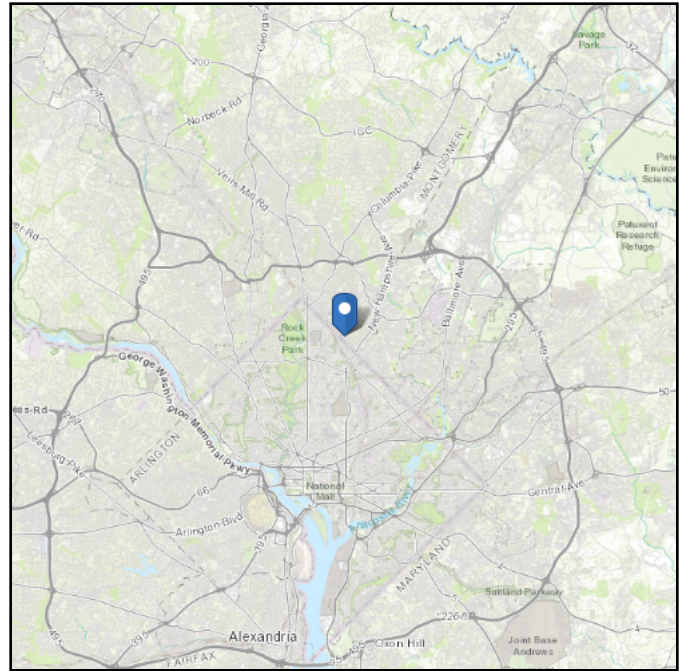
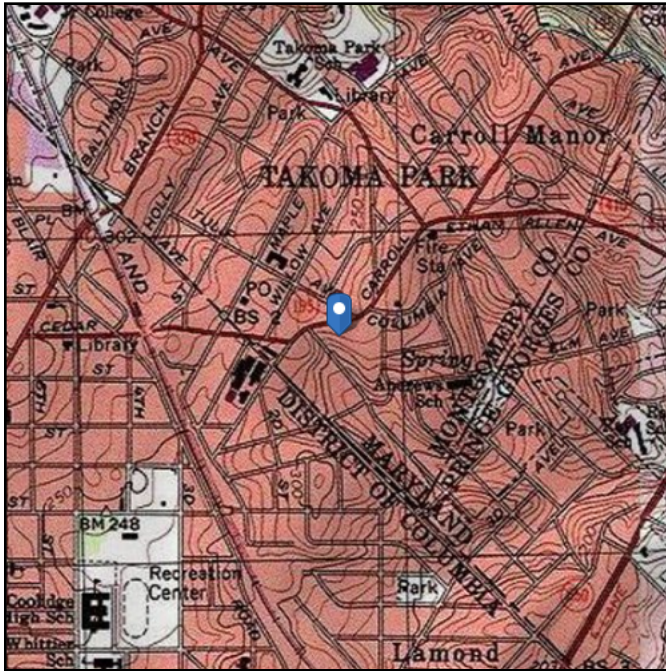

Wind

Results:

Wind Speed	113 Vmph
10-year MRI	75 Vmph
25-year MRI	84 Vmph
50-year MRI	89 Vmph
100-year MRI	95 Vmph

Data Source: ASCE/SEI 7-16, Fig. 26.5-1B and Figs. CC.2-1–CC.2-4, and Section 26.5.2
Date Accessed: Thu May 05 2022

Value provided is 3-second gust wind speeds at 33 ft above ground for Exposure C Category, based on linear interpolation between contours. Wind speeds are interpolated in accordance with the 7-16 Standard. Wind speeds correspond to approximately a 7% probability of exceedance in 50 years (annual exceedance probability = 0.00143, MRI = 700 years).

Site is not in a hurricane-prone region as defined in ASCE/SEI 7-16 Section 26.2.

Site Soil Class: D - Default (see Section 11.4.3)

Results:

S_s :	0.133	S_{D1} :	0.069
S_1 :	0.043	T_L :	8
F_a :	1.6	PGA :	0.069
F_v :	2.4	PGA _M :	0.11
S_{MS} :	0.213	F_{PGA} :	1.6
S_{M1} :	0.103	I_e :	1
S_{DS} :	0.142	C_v :	0.7

Seismic Design Category B

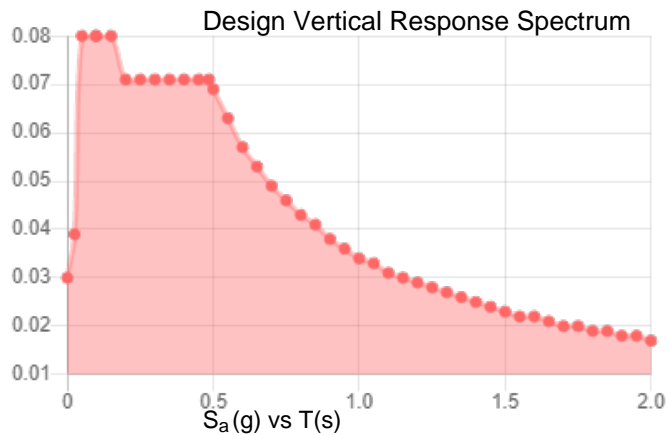
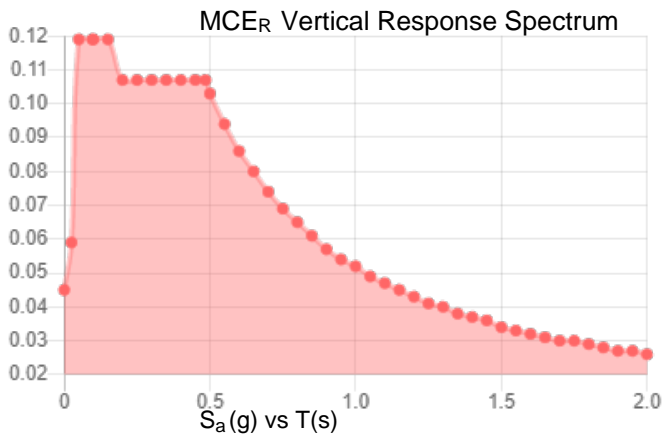
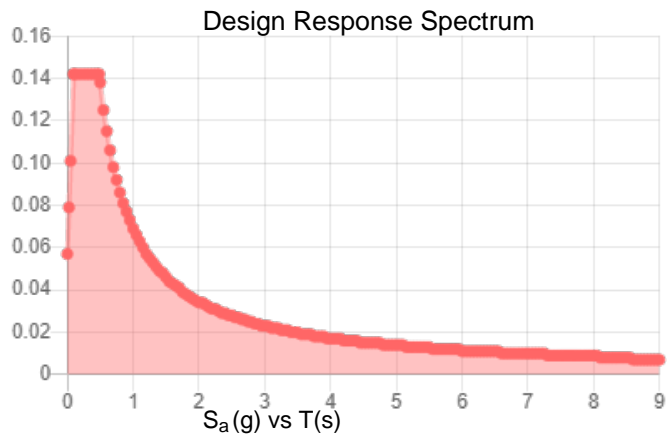
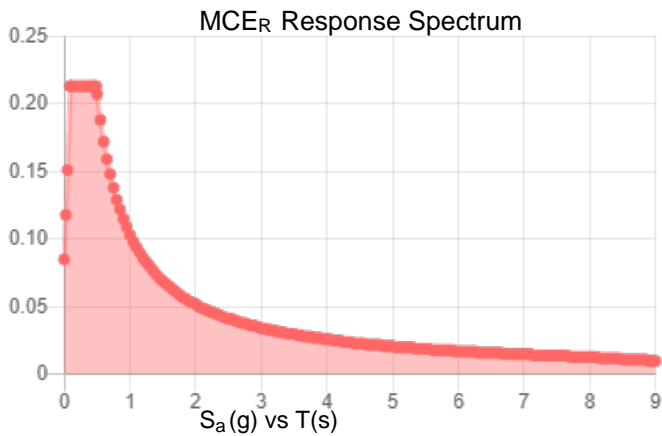

Data Accessed: Thu May 05 2022

Date Source:

USGS Seismic Design Maps based on ASCE/SEI 7-16 and ASCE/SEI 7-16 Table 1.5-2. Additional data for site-specific ground motion procedures in accordance with ASCE/SEI 7-16 Ch. 21 are available from USGS.

Ice

Results:

Ice Thickness: 1.00 in.
Concurrent Temperature: 15 F
Gust Speed 40 mph

Data Source: Standard ASCE/SEI 7-16, Figs. 10-2 through 10-8

Date Accessed: Thu May 05 2022

Ice thicknesses on structures in exposed locations at elevations higher than the surrounding terrain and in valleys and gorges may exceed the mapped values.

Values provided are equivalent radial ice thicknesses due to freezing rain with concurrent 3-second gust speeds, for a 500-year mean recurrence interval, and temperatures concurrent with ice thicknesses due to freezing rain. Thicknesses for ice accretions caused by other sources shall be obtained from local meteorological studies. Ice thicknesses in exposed locations at elevations higher than the surrounding terrain and in valleys and gorges may exceed the mapped values.

The ASCE 7 Hazard Tool is provided for your convenience, for informational purposes only, and is provided “as is” and without warranties of any kind. The location data included herein has been obtained from information developed, produced, and maintained by third party providers; or has been extrapolated from maps incorporated in the ASCE 7 standard. While ASCE has made every effort to use data obtained from reliable sources or methodologies, ASCE does not make any representations or warranties as to the accuracy, completeness, reliability, currency, or quality of any data provided herein. Any third-party links provided by this Tool should not be construed as an endorsement, affiliation, relationship, or sponsorship of such third-party content by or from ASCE.

ASCE does not intend, nor should anyone interpret, the results provided by this Tool to replace the sound judgment of a competent professional, having knowledge and experience in the appropriate field(s) of practice, nor to substitute for the standard of care required of such professionals in interpreting and applying the contents of this Tool or the ASCE 7 standard.

In using this Tool, you expressly assume all risks associated with your use. Under no circumstances shall ASCE or its officers, directors, employees, members, affiliates, or agents be liable to you or any other person for any direct, indirect, special, incidental, or consequential damages arising from or related to your use of, or reliance on, the Tool or any information obtained therein. To the fullest extent permitted by law, you agree to release and hold harmless ASCE from any and all liability of any nature arising out of or resulting from any use of data provided by the ASCE 7 Hazard Tool.

PROJECT DESCRIPTION

AT&T WIRELESS PROPOSES TO MODIFY AN EXISTING WIRELESS INSTALLATION. THE SCOPE WILL CONSIST OF THE FOLLOWING:

ROOFTOP SOW

- DECOM (4) EXISTING 1-5/8" COAX AND LEAVE IN-PLACE
• DECOM (2) EXISTING 7/8" COAX AND LEAVE IN-PLACE
• REMOVE (3) EXISTING KATHREIN 742 264 ANTENNAS
• REMOVE (E) TMS/DIPLEXERS IN POS. 1
• USE EXISTING SPARE 6 AWG DC TRUNKS

- INSTALL (3) PROPOSED AEQK ANTENNAS IN POS. 1
• INSTALL (3) PROPOSED AEQU ANTENNAS IN POS. 1

GROUND SOW

- DECOM EXISTING UMTS
• REMOVE EXISTING 9412 CABINET
• RELOCATE EVERYTHING INSIDE THE EXISTING 9412 CABINET TO THE PROPOSED FLX21-V2 CABINET

- INSTALL (1) PROPOSED 48V RECTIFIER IN (E) NETSURE 7100 PP
• INSTALL (4) PROPOSED DEKA FAHRENHEIT HT170ET BATTERIES
• INSTALL (1) PROPOSED FLX21-V2 CABINET
• INSTALL (1) PROPOSED FSM4 INSIDE PROPOSED FLX21-V2 CABINET
• INSTALL (1) PROPOSED 100A BREAKER
• INSTALL (6) PROPOSED 40A BREAKERS
• INSTALL (2) PROPOSED 30A BREAKERS

- NO SITE/CIVIL WORK

FA# 10072888 USID#3939

TULIP AVE



5G NR 1SR CBAND ROOFTOP

ENGINEERING

2015 INTERNATIONAL BUILDING CODE OR LATEST EDITION
2014 NATIONAL ELECTRIC CODE OR LATEST EDITION
TIA-222-H OR LATEST EDITION

GENERAL NOTES

THE FACILITY IS UNMANNED AND NOT FOR HUMAN HABITATION. A TECHNICIAN WILL VISIT THE SITE AS REQUIRED FOR ROUTINE MAINTENANCE. THE PROJECT WILL NOT RESULT IN ANY SIGNIFICANT DISTURBANCE OR EFFECT ON DRAINAGE; NO SANITARY SEWER SERVICE, POTABLE WATER, OR TRASH DISPOSAL IS REQUIRED AND NO COMMERCIAL SIGNAGE IS PROPOSED.

RFDS

RFDS ID: 4445171 DATE UPDATED 02/25/22.



Jacobs

Challenging today. Reinventing tomorrow.
Jacobs Telecommunications, Inc.
7150 STANDARD DR. SUITE B
HANOVER, MD 21076
443.230.4400x113



APPROVALS

THE FOLLOWING PARTIES HEREBY APPROVE AND ACCEPT THESE DOCUMENTS AND AUTHORIZE THE CONTRACTOR TO PROCEED WITH THE CONSTRUCTION DESCRIBED HEREIN. ALL DOCUMENTS ARE SUBJECT TO REVIEW BY THE LOCAL BUILDING DEPARTMENT AND MAY IMPOSE CHANGES OR MODIFICATIONS.

Approval signature lines for AT&T RF, AT&T OPERATIONS, AT&T SITE AQ, OCI, TOWER/PROPERTY OWNER, and MUNICIPAL.

DRAWING INDEX

Table with columns SHEET NO. and SHEET TITLE. Includes entries for T-1 (TITLE SHEET), C-1 (ROOFTOP PLAN), C-2 (SITE DETAILS), C-3 (RF SIGNAGE AND MITIGATION), S-1 (GROUND EQUIPMENT LAYOUT), S-2 (SITE ELEVATION), S-3 (EXISTING & PROPOSED ANTENNA LAYOUT), E-1 (POWER ANALYSIS), E-2 (DC TRUNK CABLE CALCULATOR), E-3 (GROUNDING DETAILS), RF-1 (ANTENNA CHART AND PLUMBING DIAGRAM), RF-2 (COLOR CODE CHART), RF-3 (LTE RET NAMING CONVENTION).

APPROVALS

Approval signature lines for LANDLORD, LEASING, R.F., ZONING, CONSTRUCTION, and A & E.

PROJECT NO: EP4TURWL

DRAWN BY: CRO

CHECKED BY: LW

SUBMITTALS

Table with columns for date and description of submittals. Includes entries for 11/01/22 (PERMITTING COMMENTS), 09/27/22 (JX COMMENTS), 08/23/22 (ISSUED), 06/13/22 (REVISION), 06/01/22 (ISSUED), 06/01/22 (REVISION), and 04/27/22 (ISSUED FOR REVIEW).

THIS DOCUMENT IS THE CREATION, DESIGN, PROPERTY AND COPYRIGHTED WORK OF AT&T WIRELESS. ANY DUPLICATION OR USE WITHOUT EXPRESS WRITTEN CONSENT IS STRICTLY PROHIBITED. DUPLICATION AND USE BY GOVERNMENT AGENCIES FOR THE PURPOSE OF CONDUCTING THEIR LAWFULLY AUTHORIZED REGULATORY AND ADMINISTRATIVE FUNCTIONS ARE SPECIFICALLY ALLOWED.

FA# 10072888
USID# 3939
TULIP AVE
7051 CARROLL STREET
TAKOMA PARK, MD 20912

TITLE SHEET

T-1
67

SITE INFORMATION

LANDLORD: TAKOMA TOWER LP
LANDLORD SITE NUMBER: N/A
SITE NAME: TULIP AVE
USID NUMBER: 3939
FA NUMBER: 10072888
SITE ADDRESS: 7051 CARROL STREET TAKOMA PARK, MD 20912 MONTGOMERY
COUNTY: MONTGOMERY
LATITUDE (NAD 83): N 38° 58' 29.089" (38.97474)
LONGITUDE (NAD 83): W 77° 00' 37.573" (-77.010437)
RAD CENTER: 107°, 115' & 129' AGL
SITE ACQUISITION CONTACT: ANDREW CAPACI Andrew.Capaci@jacobs.com
RF ENGINEER: SANDEEP GUPTA AA913P@att.com
C&E MANAGER: STEVEN SAFIRE SS0091@att.com
JURISDICTION: MONTGOMERY COUNTY
APPLICANT/LESSEE: AT&T 7150 STANDARD DRIVE SUITE A HANOVER, MD 21076

LOCATION MAPS

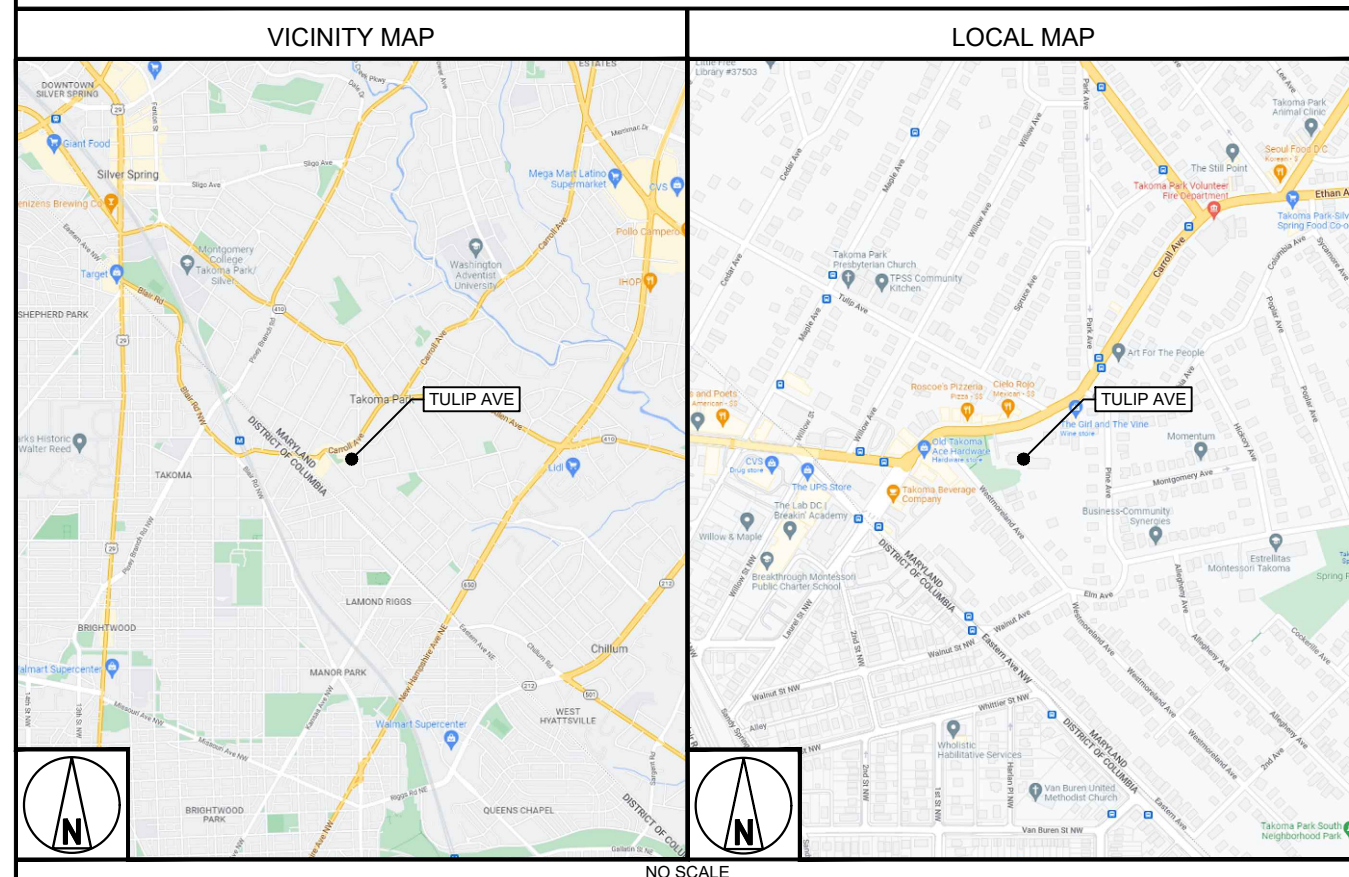

DRIVING DIRECTIONS

DIRECTIONS FROM AT&T OFFICE: START OUT FROM 7150 STANDARD DR. HANOVER MD HEAD SOUTHWEST TOWARD STANDARD DR. TURN LEFT TOWARD STANDARD DR. TURN RIGHT ONTO STANDARD DR. TURN LEFT ONTO PARKWAY DR. TURN RIGHT ONTO PARK CIR DR. TURN LEFT ONTO COCA COLA DR. SLIGHT RIGHT TO MERGE ONTO MD-100 W TOWARD ELLICOTT CITY MERGE ONTO MD-100 W TAKE THE EXIT ONTO I-95 S TOWARD WASHINGTON TAKE EXIT 27 W TO MERGE ONTO I-495 W TOWARD SILVER SPRING TAKE EXIT 28B TO MERGE ONTO MD-650 S/NEW HAMPSHIRE AVE TOWARD TAKOMA PARK MERGE ONTO MD-650 S/NEW HAMPSHIRE AVE. SLIGHT RIGHT TOWARD MD-320 S/PINEY BRANCH RD. MERGE ONTO MD-320 S/PINEY BRANCH RD. TURN LEFT ONTO CARROLL AVE. TURN LEFT, TURN LEFT DESTINATION WILL BE ON THE RIGHT.

CONTACT INFORMATION

ENGINEER: JACOBS TELECOMMUNICATIONS, INC. 7150 STANDARD DRIVE, SUITE B HANOVER, MD 21076
CONTACT: LEAH WOOLLY
PHONE: 443.230.4400x113



UNDERGROUND SERVICE ALERT
MISS UTILITY 811
48 HOURS BEFORE YOU DIG



APPROVALS

LANDLORD _____

LEASING _____

R.F. _____

ZONING _____

CONSTRUCTION _____

A & E _____

PROJECT NO: EP4TURWL

DRAWN BY: CRO

CHECKED BY: LW

SUBMITTALS

NO.	DATE	DESCRIPTION
4	11/01/22	PERMITTING COMMENTS
3	09/27/22	JX COMMENTS
2	08/23/22	ISSUED
1	06/13/22	REVISION
0	06/01/22	ISSUED
B	06/01/22	REVISION
A	04/27/22	ISSUED FOR REVIEW

THIS DOCUMENT IS THE CREATION, DESIGN, PROPERTY AND COPYRIGHTED WORK OF AT&T WIRELESS. ANY DUPLICATION OR USE WITHOUT EXPRESS WRITTEN CONSENT IS STRICTLY PROHIBITED. DUPLICATION AND USE BY GOVERNMENT AGENCIES FOR THE PURPOSE OF CONDUCTING THEIR LAWFULLY AUTHORIZED REGULATORY AND ADMINISTRATIVE FUNCTIONS ARE SPECIFICALLY ALLOWED.

FA# 10072888
 USID# 3939
 TULIP AVE
 7051 CARROL STREET
 TAKOMA PARK, MD 20912

ROOFTOP PLAN

C-1
68

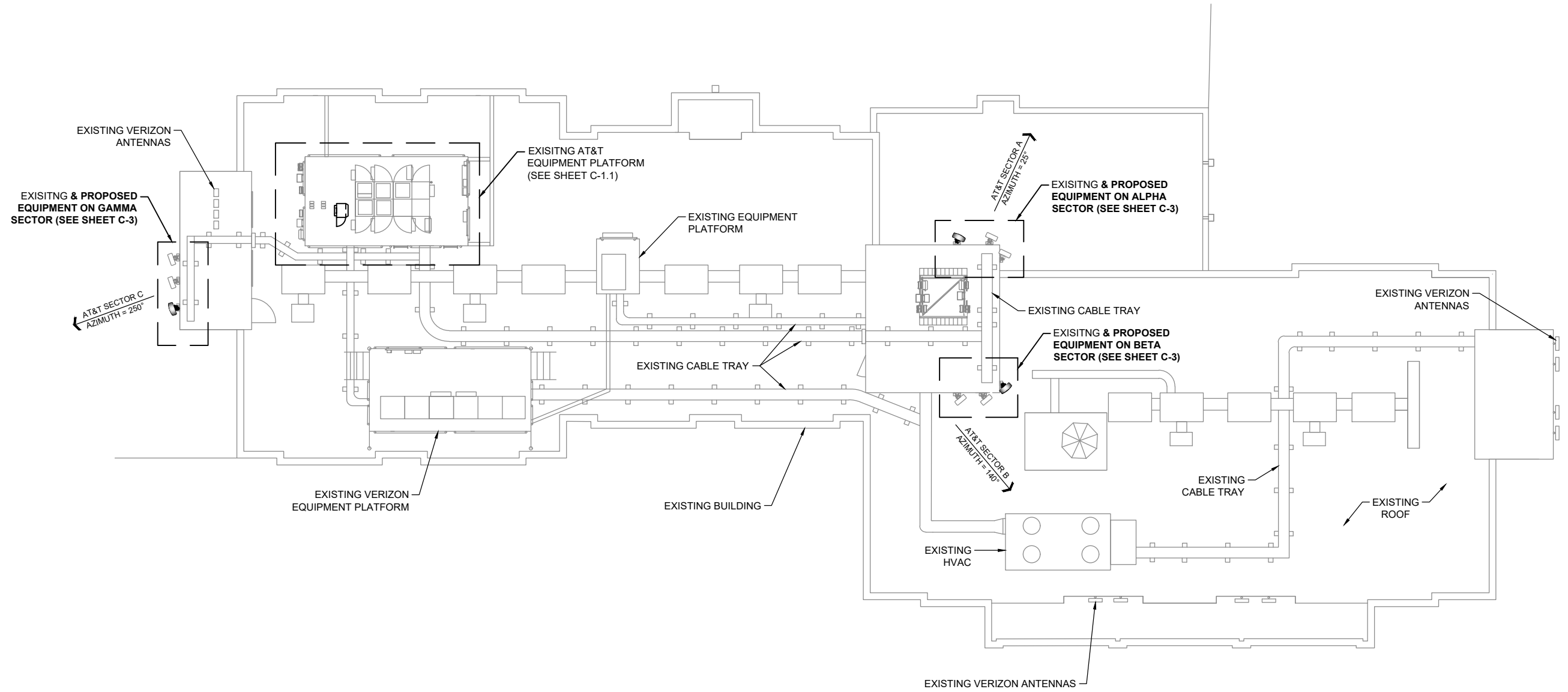

MANUFACTURER: NOKIA
 MODEL NO.: AEQK AIRSCALE MAA 64T64R 192AE n77 200w
 TECHNOLOGY: 5G CBAND
 DIMENSIONS (HxWxD): 29.53" x 17.72" x 9.53"
 WEIGHT (lbs): <99.21
 POWER SUPPLY: DC -40.5V TO -57V
 TEMP. W/O SOLAR LOAD: -40°C TO 55°C

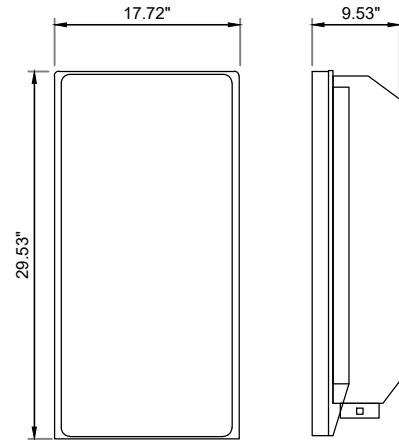

NOTE: ALL NEW ANTENNAS WILL BE PAINTED TO MATCH.

MANUFACTURER: NOKIA
 MODEL NO.: AEQU AIRSCALE MAA 64T64R 192AE n77 200w
 TECHNOLOGY: 5G DOD
 DIMENSIONS (HxWxD): 29.53" x 17.72" x 9.45"
 WEIGHT (lbs): <99.21
 POWER SUPPLY: DC -40.5V TO -57V
 TEMP. W/O SOLAR LOAD: -40°C TO 55°C

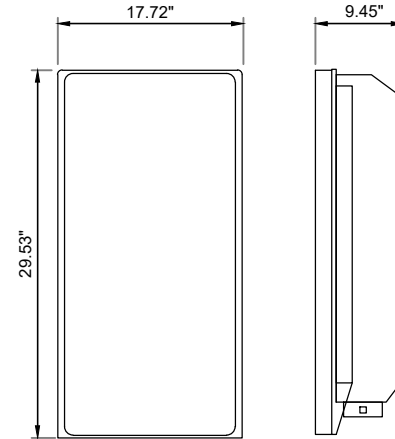

NOTE: ALL NEW ANTENNAS WILL BE PAINTED TO MATCH.

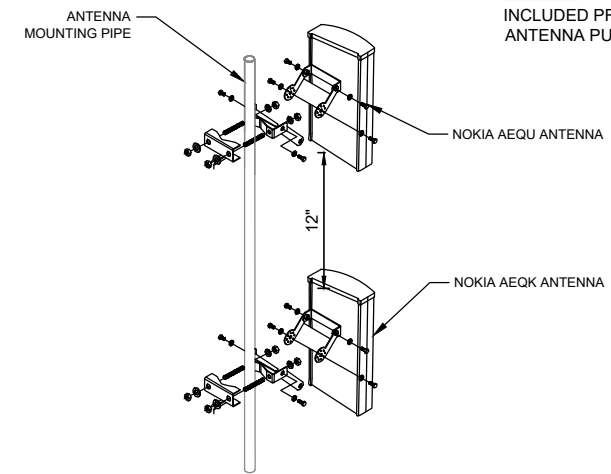

NOTE:
 INCLUDED PRODUCTS WITH
 ANTENNA PURCHASE



Jacobs
 Challenging today.
 Reinventing tomorrow.
 Jacobs Telecommunications, Inc.
 7150 STANDARD DR. SUITE B
 HANOVER, MD 21076
 443.230.4400x113

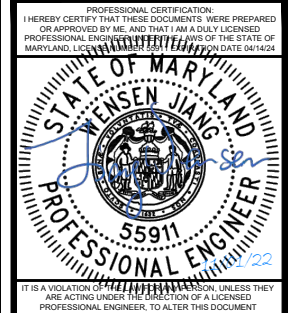

1 AEQK AIRSCALE MAA 64T64R 192AE n77 200w

SCALE: NTS

2 AEQU AIRSCALE MAA 64T64R 192AE n77 200w

SCALE: NTS

3 CBAND MOUNTING DETAIL

SCALE: NTS

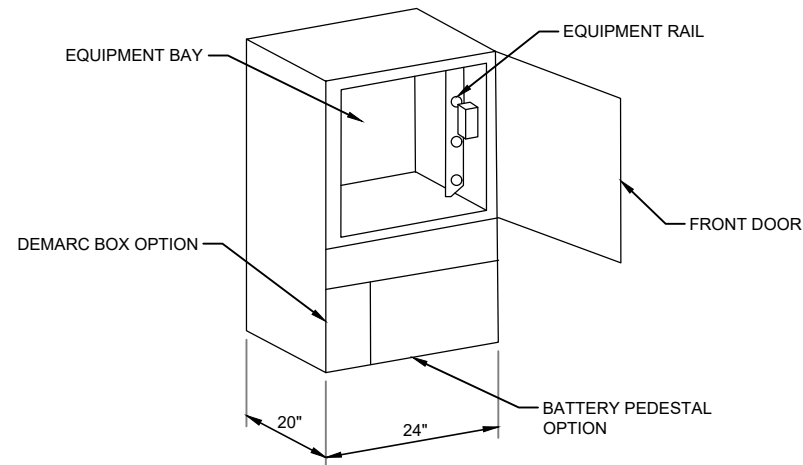

4 FLEX21-V2 CABINET

SCALE: NTS

5 DETAIL NOT USED

SCALE: NTS

6 DETAIL NOT USED

SCALE: NTS

APPROVALS

LANDLORD _____

LEASING _____

R.F. _____

ZONING _____

CONSTRUCTION _____

A & E _____

PROJECT NO: EP4TURWL

DRAWN BY: CRO

CHECKED BY: LW

SUBMITTALS	
4	11/01/22 PERMITTING COMMENTS
3	09/27/22 JX COMMENTS
2	08/23/22 ISSUED
1	06/13/22 REVISION
0	06/01/22 ISSUED
B	06/01/22 REVISION
A	04/27/22 ISSUED FOR REVIEW

THIS DOCUMENT IS THE CREATION, DESIGN, PROPERTY AND COPYRIGHTED WORK OF AT&T. WITHOUT EXPRESS WRITTEN CONSENT OF AT&T, NO PART OF THIS DOCUMENT IS TO BE REPRODUCED, COPIED, TRANSMITTED, OR IN ANY MANNER DISCLOSED TO ANY OTHER PERSON OR ENTITY. THIS DOCUMENT IS NOT TO BE USED FOR ANY OTHER PROJECT OR PURPOSE WITHOUT THE EXPRESS WRITTEN CONSENT OF AT&T.

FA# 10072888
 USID# 3939
 TULIP AVE
 7051 CARROL STREET
 TAKOMA PARK, MD 20912

SITE DETAILS

7 DETAIL NOT USED

SCALE: NTS

8 DETAIL NOT USED

SCALE: NTS

9 DETAIL NOT USED

SCALE: NTS



Signage and barriers are the primary means of mitigating access to accessible areas of exposure. Below is a summary of existing and recommended signage at this AT&T facility.

Existing Signage and Barriers (AT&T Sectors)										
Location	Information	Notice	Notice 2	Caution	Caution 2	Caution 2B	Caution 2C	Warning	Warning 2	Barriers
PH Ladder	0	0	0	0	1	0	0	0	0	0
Alpha	0	0	0	0	3	0	0	0	0	0
Beta	0	0	0	0	3	0	0	0	0	0
Gamma	0	0	0	0	2	0	0	0	0	0

Recommended Signage and Barriers (AT&T Sectors) – Actions that MUST be Taken						
Location	Notice 2	Caution 2	Caution 2B	Caution 2C	Warning 2	Barriers
PH Ladder	0	0	0	0	0	0
Alpha	0	0	0	0	0	0
Beta	0	12	0	0	0	X
Gamma	0	0	0	0	0	0

Final Compliant Configuration (AT&T Sectors) – All Mitigation Items that MUST be in Place										
Location	Information	Notice	Notice 2	Caution	Caution 2	Caution 2B	Caution 2C	Warning	Warning 2	Barriers
PH Ladder	0	0	0	0	0	0	0	0	0	0
Alpha	0	0	0	0	3	0	0	0	0	0
Beta	0	0	0	0	15	0	0	0	0	X
Gamma	0	0	0	0	2	0	0	0	0	0

Beta:

- Install a 75' barrier (11'x53'x11' segments) with an estimated (12) stanchions. Install (12) Caution 2 signs on the barrier.

Notes:

- Ensure all barriers are at least 6' away from any unprotected roof edges.
- The existing Caution 2 sign on PH1 ladder is not required and can be removed.
- The existing Caution 2 signs on Gamma sector are not required. However, they are not recommended to be removed to account for future carrier adds.



2.0 SITE SCALE MAP

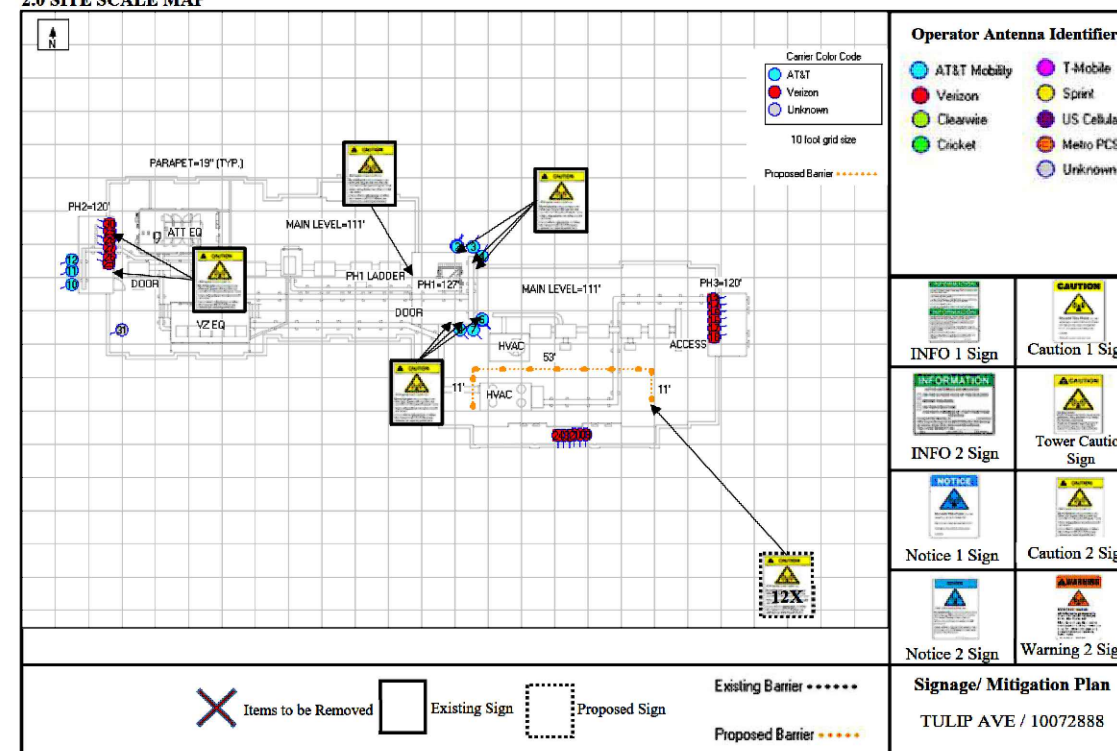

APPROVALS

LANDLORD _____

LEASING _____

R.F. _____

ZONING _____

CONSTRUCTION _____

A & E _____

PROJECT NO: EP4TURWL

DRAWN BY: CRO

CHECKED BY: LW

SUBMITTALS	
4	11/01/22 PERMITTING COMMENTS
3	09/27/22 JX COMMENTS
2	08/23/22 ISSUED
1	06/13/22 REVISION
0	06/01/22 ISSUED
B	06/01/22 REVISION
A	04/27/22 ISSUED FOR REVIEW

THIS DOCUMENT IS THE CREATION, DESIGN, PROPERTY AND COPYRIGHTED WORK OF AT&T. WITHOUT EXPRESS WRITTEN CONSENT IS STRICTLY PROHIBITED, DUPLICATION AND USE BY GOVERNMENT AGENCIES FOR THE PURPOSE OF CONDUCTING THEIR LAWFULLY AUTHORIZED REGULATORY AND ADMINISTRATIVE FUNCTIONS ARE SPECIFICALLY ALLOWED.

FA# 10072888
 USID# 3939
 TULIP AVE
 7051 CARROL STREET
 TAKOMA PARK, MD 20912

RF SIGNAGE AND MITIGATION

C-3
 70



Jacobs
 Challenging today.
 Reinventing tomorrow.



APPROVALS

LANDLORD _____

LEASING _____

R.F. _____

ZONING _____

CONSTRUCTION _____

A & E _____

PROJECT NO: EP4TURWL

DRAWN BY: CRO

CHECKED BY: LW

SUBMITTALS	
4	11/01/22 PERMITTING COMMENTS
3	09/27/22 JX COMMENTS
2	08/23/22 ISSUED
1	06/13/22 REVISION
0	06/01/22 ISSUED
B	06/01/22 REVISION
A	04/27/22 ISSUED FOR REVIEW

THIS DOCUMENT IS THE CREATION, DESIGN, PROPERTY AND COPYRIGHTED WORK OF AT&T. WITHOUT EXPRESS WRITTEN CONSENT IS STRICTLY PROHIBITED, DUPLICATION AND USE BY GOVERNMENT AGENCIES FOR THE PURPOSE OF CONDUCTING THEIR LAWFULLY AUTHORIZED REGULATORY AND ADMINISTRATIVE FUNCTIONS ARE SPECIFICALLY ALLOWED.

FA# 10072888
 USID# 3939
 TULIP AVE
 7051 CARROL STREET
 TAKOMA PARK, MD 20912

GROUND EQUIPMENT LAYOUT

S-1
 71

GROUND SCOPE OF WORK:

- DECOM (E) UMTS
- REMOVE (E) 9412 CABINET
- INSTALL (1)(N) 48V RECTIFIER IN (E) NETSURE 7100 PP
- INSTALL (4)(N) DEKA FAHRENHEIT HT170ET BATTERIES IN (E) BATTERY RACK
- INSTALL (N) FLX21-V2 CABINET
- RELOCATE EVERYTHING INSIDE THE (E) 9412 CABINET TO THE (N) FLX21-V2 CABINET
- INSTALL (N) FSM4 INSIDE (N) FLX21-V2 CABINET
- INSTALL (1)(N) 100A BREAKER FOR (N) FLX21-V2 CABINET
- INSTALL (3)(N) 40A BREAKERS FOR (N) AEQ
- INSTALL (3)(N) 40A BREAKERS FOR (N) AEQU
- INSTALL (2)(N) 30A BREAKERS FOR (E) FSM4 CHASSIS (CBAND)

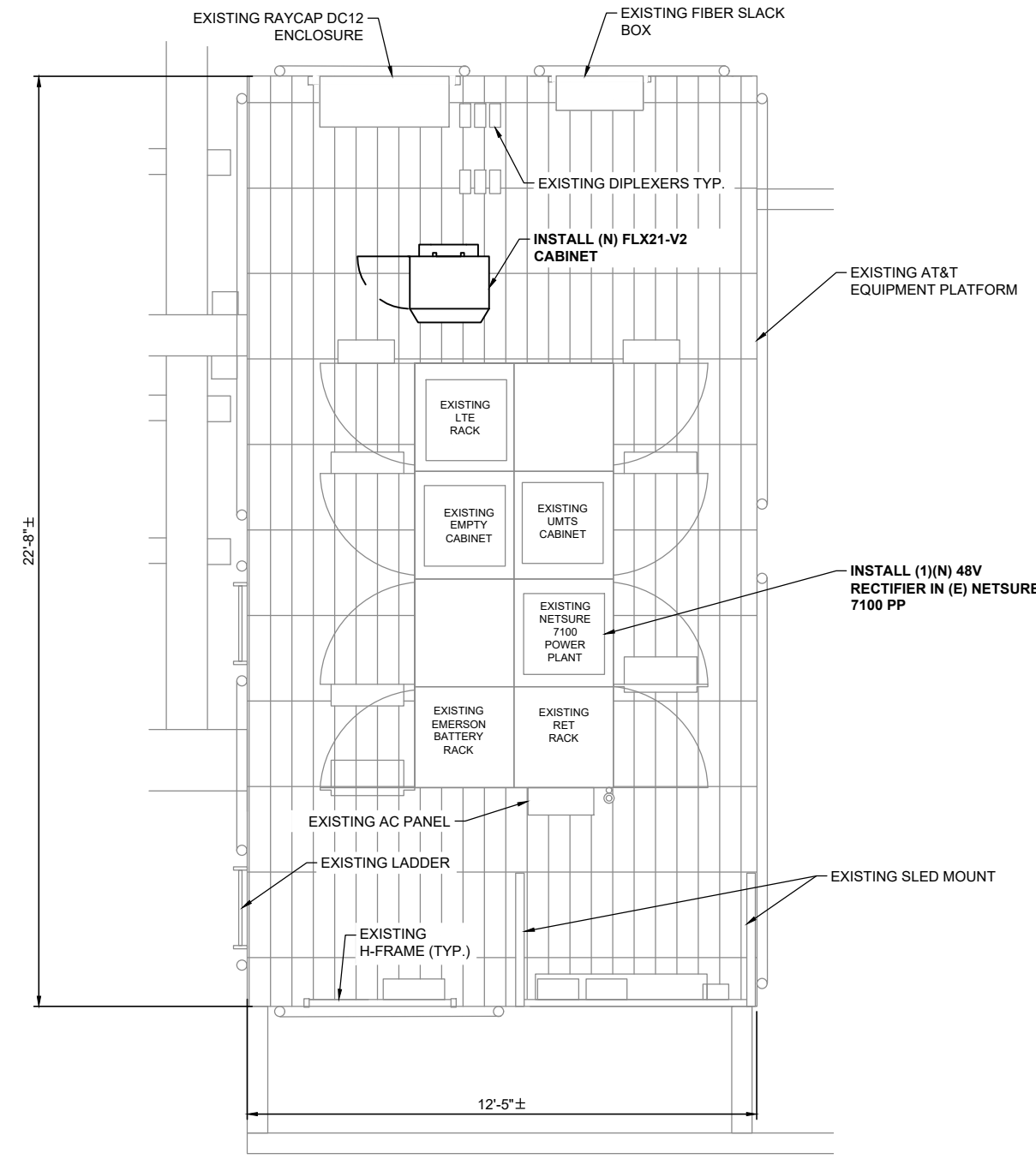
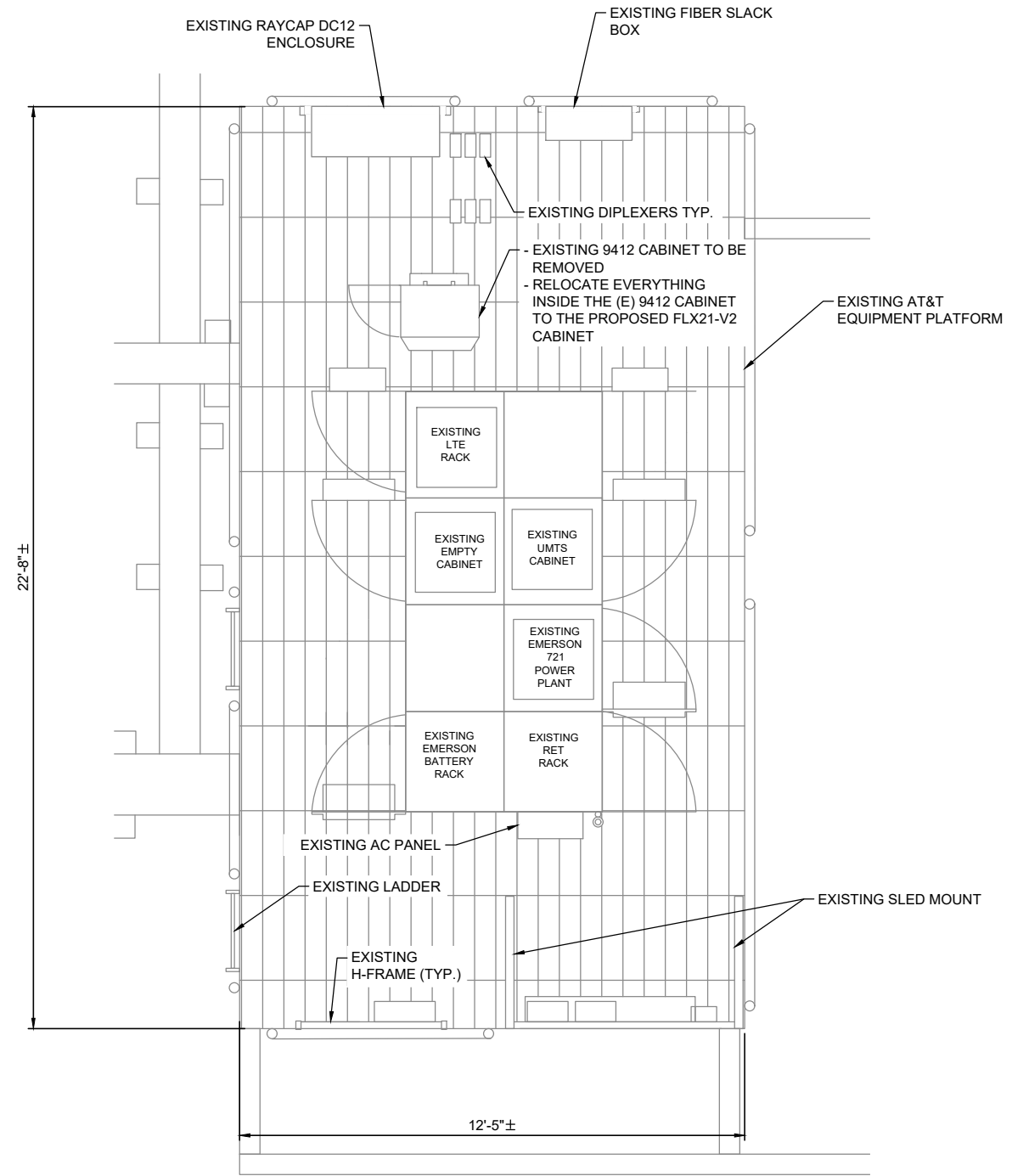

1 EXISTING EQUIPMENT PLAN

2 PROPOSED EQUIPMENT PLAN

SCALE:
 1/2" = 1'-0"

NOTES:

- EXISTING TOWER INFORMATION IS PROVIDED FOR REFERENCE ONLY. JACOBS TELECOMMUNICATIONS, INC. IS NOT RESPONSIBLE FOR THE ANALYSIS/DESIGN OF THE EXISTING TOWER, ITS CONNECTIONS & FOUNDATIONS. A STRUCTURAL ANALYSIS OF THE EXISTING TOWER AND FOUNDATIONS PERFORMED BY OTHERS. CONTRACTOR SHALL REFER TO THE LATEST STRUCTURAL ANALYSIS REPORT. MODIFICATIONS TO THE TOWER OR FOUNDATION THAT ARE NEEDED MUST BE PERFORMED PRIOR TO THE INSTALLATION OF THE EQUIPMENT SHOWN ON THE DRAWINGS.
- CONTRACTOR SHALL VERIFY THE EXISTING ANTENNA CENTERLINE HEIGHT ABOVE GROUND LEVEL. PROPOSED ANTENNA CENTERLINE SHALL MATCH EXISTING.

NOTES:

- ALL CABLES SHALL BE GROUNDED WITH COAXIAL CABLE GROUNDING KITS. FOLLOW THE MANUFACTURER'S RECOMMENDATIONS.
 - GROUNDED AT THE ANTENNA LEVEL.
 - GROUNDED AT MID LEVEL, TOWERS WHICH ARE OVER 200', ADDITIONAL CABLE ROUNDING REQUIRED.
 - GROUNDED AT BASE OF TOWER PRIOR TO TURNING HORIZONTAL.
 - GROUNDED OUTSIDE THE EQUIPMENT SHELTER AT ENTRY PORT.
 - GROUNDED INSIDE THE EQUIPMENT SHELTER AT THE ENTRY PORT.
- ALL PROPOSED GROUNDING BAR DOWNLOADS ARE TO BE TERMINATED TO THE EXISTING ADJACENT GROUNDING BAR DOWNLOADS A MINIMUM DISTANCE OF 4'-0" BELOW GROUNDING BAR. TERMINATIONS MAY BE EXOTHERMIC OR COMPRESSION.
- ALL CONNECTIONS FOR HANGERS, SUPPORTS, BRACING, ETC. SHALL BE INSTALLED PER TOWER MANUFACTURER'S SPECIFICATION & RECOMMENDATIONS.

ANTENNA MOUNTING NOTES:

- DESIGN AND CONSTRUCTION OF ANTENNA SUPPORTS SHALL CONFORM TO CURRENT ANSI/EIA/TIA-222 "STRUCTURAL STANDARDS FOR STEEL ANTENNA TOWERS AND ANTENNA SUPPORTING STRUCTURES" OR APPLICABLE LOCAL CODES. DESIGN WIND LOADING OBTAINED FROM ANSI/TIA-222-G, OR THE LATEST VERSION.
- ALL STEEL MATERIALS SHALL BE GALVANIZED AFTER FABRICATION IN ACCORDANCE WITH ASTM A123 "ZINC (HOT-DIP GALVANIZED) COATINGS ON IRON AND STEEL PRODUCTS", UNLESS OTHERWISE NOTED.
- ALL BOLTS, ANCHORS AND MISCELLANEOUS HARDWARE SHALL BE GALVANIZED IN ACCORDANCE WITH ASTM A153 "ZINC-COATING (HOT-DIP) ON IRON AND STEEL HARDWARE", UNLESS OTHERWISE NOTED.
- DAMAGED GALVANIZED SURFACES SHALL BE REPAIRED BY COLD GALVANIZING IN ACCORDANCE WITH ASTM A780.
- ALL ANTENNA MOUNTS SHALL BE INSTALLED WITH LOCK NUTS, DOUBLE NUTS AND SHALL BE TORQUED TO MANUFACTURER'S RECOMMENDATIONS.
- MULTI PORT ANTENNAS: TERMINATE UNUSED ANTENNA PORTS WITH CONNECTOR CAP & WEATHERPROOF THOROUGHLY. JUMPERS FROM THE TMA'S MUST TERMINATE TO OPPOSITE POLARIZATIONS IN EACH SECTOR.

COAXIAL ANTENNA CABLE NOTES:

- ALL JUMPERS TO THE ANTENNAS FROM THE MAIN TRANSMISSION LINE WILL BE 1/2" DIA. LDF AND SHALL NOT EXCEED 6'-0".
- ALL COAXIAL CABLE WILL BE SECURED TO THE DESIGNED SUPPORT STRUCTURE, IN AN APPROVED MANNER, AT DISTANCES NOT TO EXCEED 4'-0" O.C.

FIBER & POWER CABLE MOUNTING NOTES:

- CABLE TO BE SUPPORTED USING 1/2" SNAP-INS (PIM RATED)(SNAPTEK POLYMERS OR EQUIVALENT) OR 1/2" BUTTERFLY HANGERS (PIM RATED)(SNAPTEK POLYMERS OR EQUIVALENT) OR ENGINEER APPROVED EQUAL..
- CABLE TO BE SUPPORTED EVERY 3'.
- ALL SNAP-INS, RUBBER CABLE INSERTS, AND MOUNTING HARDWARE FOR FIBER AND DC CABLES SHALL BE SUPPLIED FROM ROSENBERGER.
- RUS TO BE INSTALLED WITHIN 16.4' (5.0 METERS) OF THE SURGE SUPPRESSOR. (CONTRACTOR TO FIELD VERIFY).

TORQUE REQUIREMENTS:

- ALL RF CONNECTIONS SHALL BE TIGHTENED BY A TORQUE WRENCH.
- ALL RF CONNECTIONS. GROUNDING HARDWARE AND ANTENNA HARDWARE SHALL HAVE A TORQUE MARK INSTALLED IN A CONTINUOUS STRAIGHT LINE FROM BOTH SIDES OF THE CONNECTION.
 - RF CONNECTION BOTH SIDES OF THE CONNECTOR.
 - GROUNDING AND ANTENNA HARDWARE ON THE NUT SIDE STARTING FROM THE THREADS TO THE SOLID SURFACE. EXAMPLE OF SOLID SURFACE: GROUND BAR, ANTENNA BRACKET METAL.
- ALL 8M ANTENNA HARDWARE SHALL BE TIGHTENED TO 9 LB-FT (12 NM).
- ALL 12M ANTENNA HARDWARE SHALL BE TIGHTENED TO 43 LB-FT (58 NM).
- ALL GROUNDING HARDWARE SHALL TIGHTENED UNTIL THE LOCK WASHER COLLAPSES AND THE GROUND IS NO LONGER LOOSE.
- ALL DIN TYPE CONNECTIONS ARE TO BE TORQUED TO 18-22 LB-FT (24.4 - 29.8 NM).
- ALL N TYPE CONNECTIONS ARE TO BE TORQUED TO 15-20 LB-IN (1.7 - 2.3 NM).

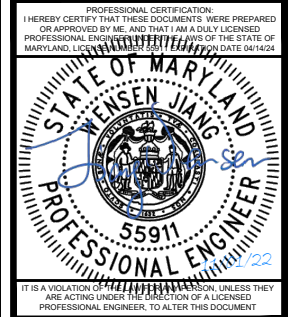
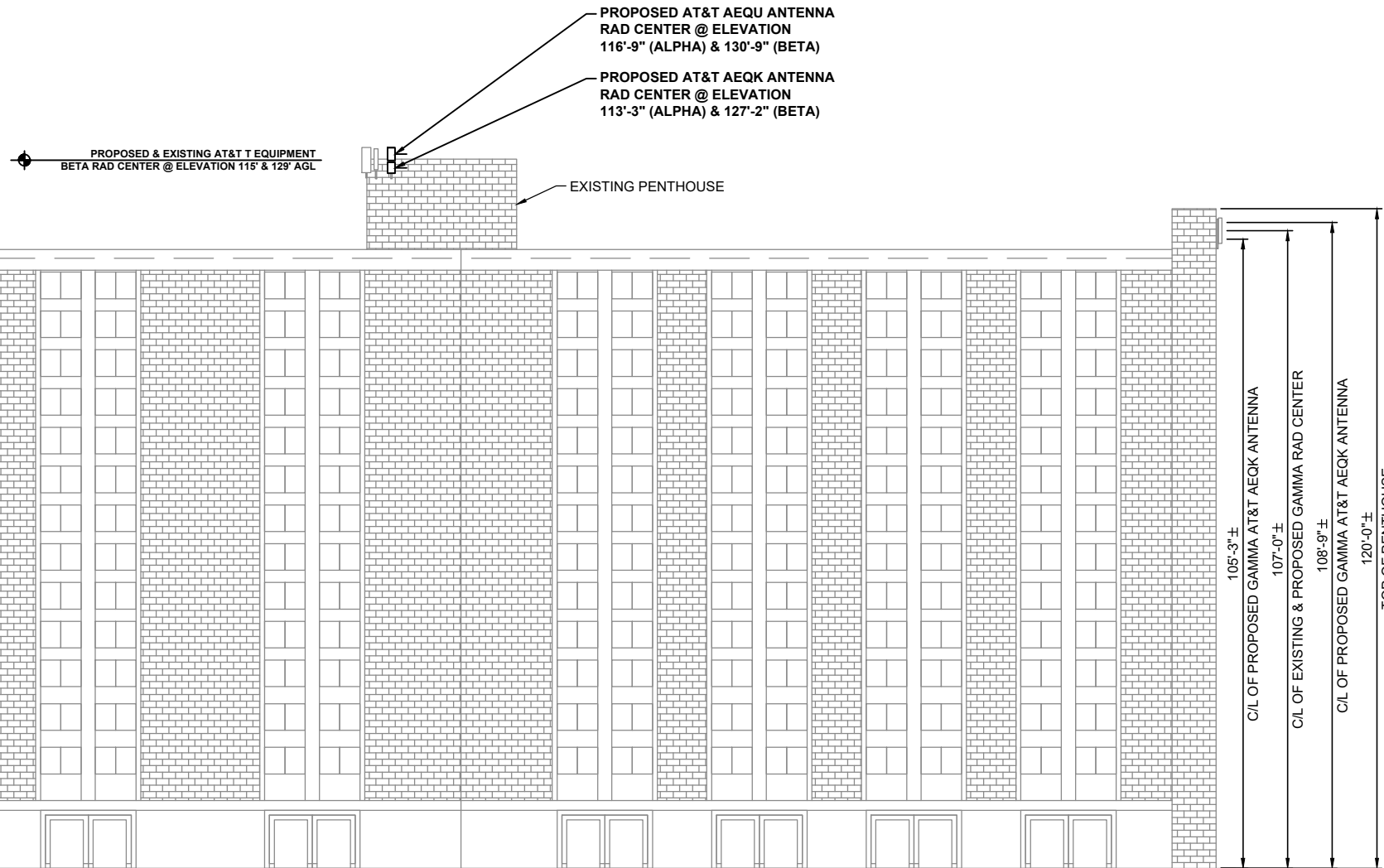

APPROVALS

LANDLORD _____

LEASING _____

R.F. _____

ZONING _____

CONSTRUCTION _____

A & E _____

PROJECT NO: EP4TURWL

DRAWN BY: CRO

CHECKED BY: LW

SUBMITTALS	
4	11/01/22 PERMITTING COMMENTS
3	09/27/22 JX COMMENTS
2	08/23/22 ISSUED
1	06/13/22 REVISION
0	06/01/22 ISSUED
B	06/01/22 REVISION
A	04/27/22 ISSUED FOR REVIEW

THIS DOCUMENT IS THE CREATION, DESIGN, PROPERTY AND COPYRIGHTED WORK OF AT&T WIRELESS. ANY DUPLICATION OR USE WITHOUT EXPRESS WRITTEN CONSENT IS STRICTLY PROHIBITED. DUPLICATION AND USE BY GOVERNMENT AGENCIES FOR THE PURPOSE OF CONDUCTING THEIR LAWFULLY AUTHORIZED REGULATORY AND ADMINISTRATIVE FUNCTIONS ARE SPECIFICALLY ALLOWED.

FA# 10072888
 USID# 3939
 TULIP AVE
 7051 CARROL STREET
 TAKOMA PARK, MD 20912

SITE ELEVATION

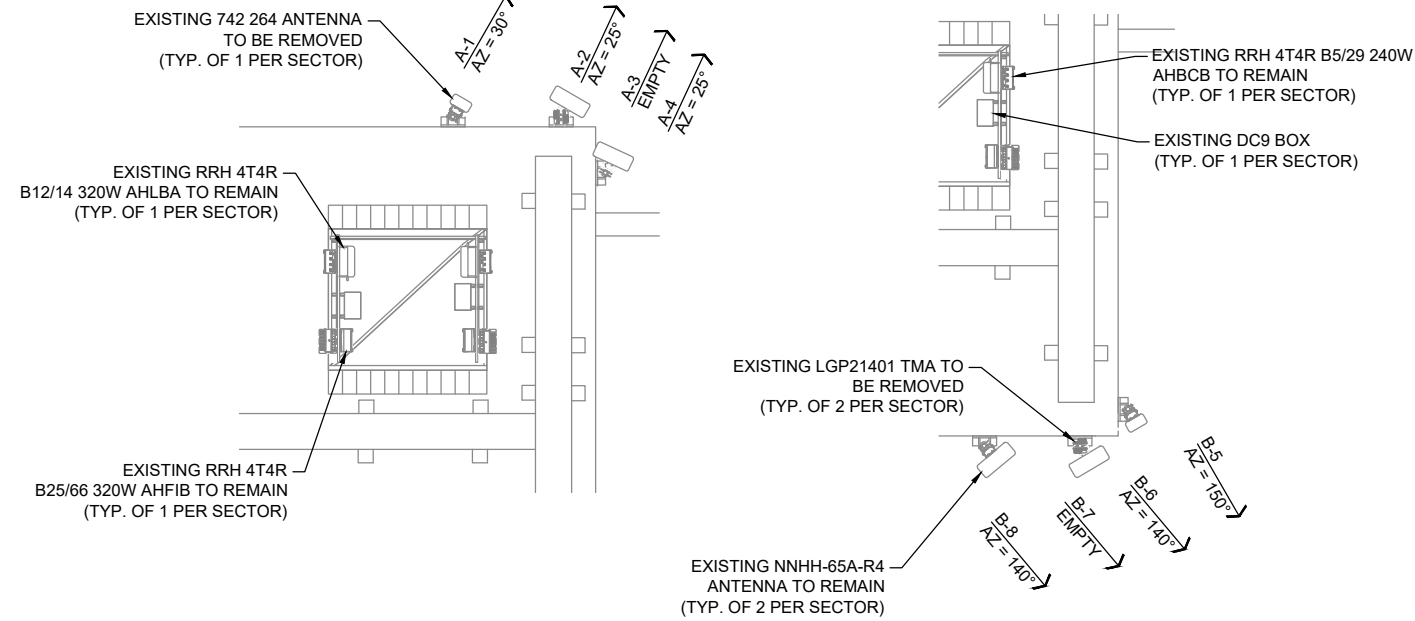

ELEVATION 115'

ELEVATION 129'

NOTES:

- CONTRACTOR TO VERIFY FINAL RF CONFIGURATION AND NOTIFY CARRIER AND ENGINEER W/ ANY DISCREPANCIES PRIOR TO THE INSTALLATION.
- CONTRACTOR SHALL NOT EXCEED MOUNTING MORE THAN (2) RRHS PER ANTENNA MOUNTING PIPE - RELOCATE TO AN ADJACENT ANTENNA MOUNTING PIPE AS NEEDED.
- CONTRACTOR SHALL REFER TO THE TOWER EQUIPMENT INSTALLATION MOUNT STRUCTURAL ANALYSIS REPORT; SITE NUMBER: N/A; SITE NAME: TULIP AVE; FA LOCATION: 10072888 ; ISSUED BY JACOBS TELECOMMUNICATIONS, INC. ON XX/XX/XX. PER THIS ANALYSIS NO MODIFICATIONS ARE REQUIRED FOR THE PROPOSED EQUIPMENT. CONTRACTOR SHALL CONFIRM ALL MOUNT MEMBERS AND PROPOSED APPURTENANCES ARE INSTALLED IN ACCORDANCE WITH THIS REPORT.

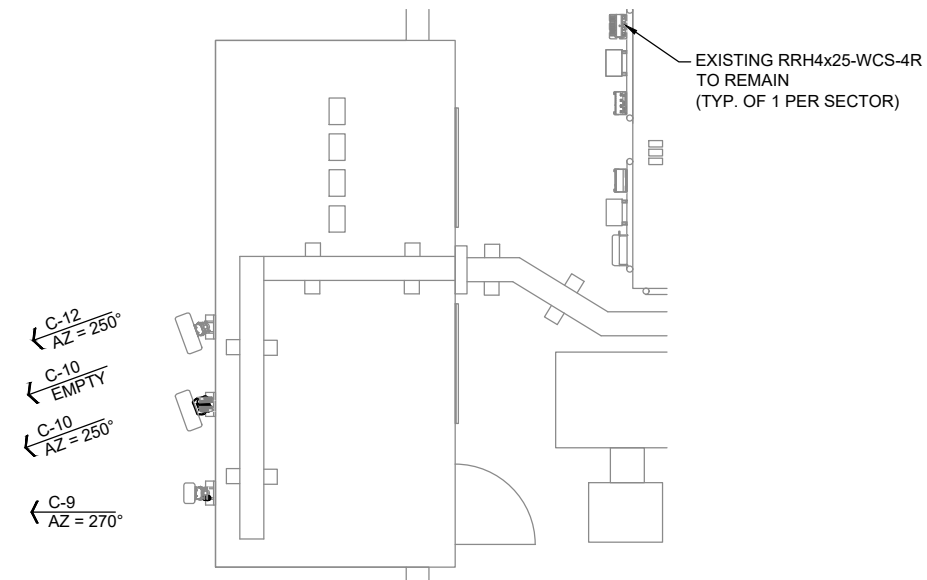

ELEVATION 107'

1 EXISTING ANTENNA LAYOUT

SCALE: 1/4" = 1'-0"



NOTE: ALL NEW ANTENNAS WILL BE PAINTED TO MATCH.

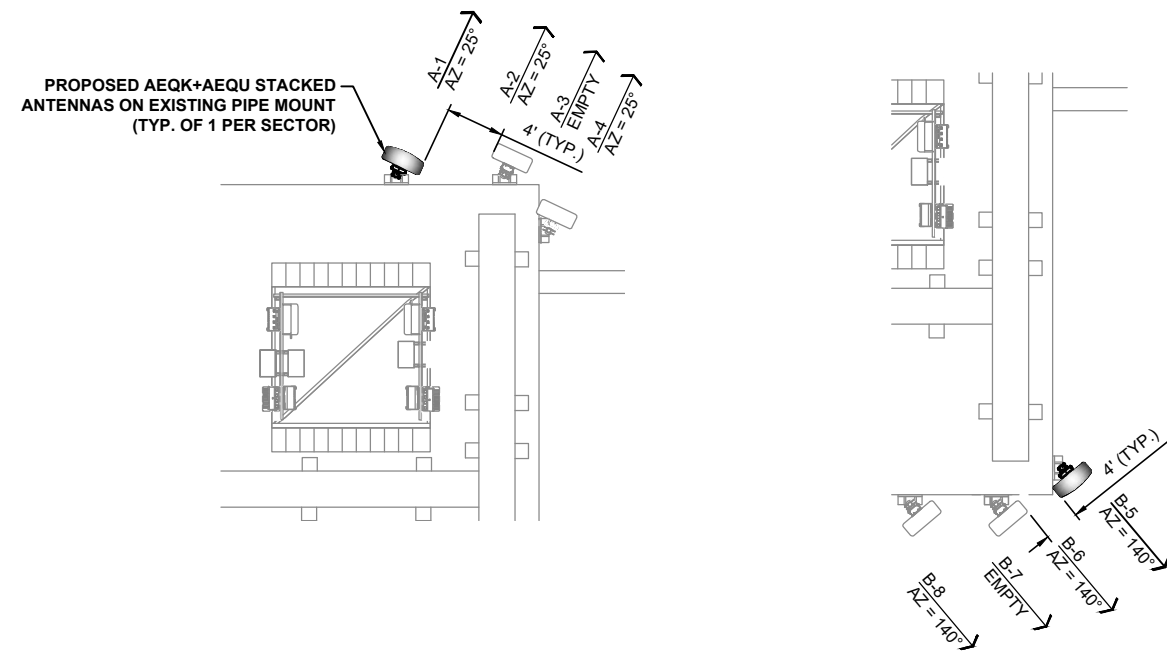

ELEVATION 115'

ELEVATION 129'

TOWER SCOPE OF WORK:

- DECOM (4)(E) 1-5/8" COAX AND LEAVE IN-PLACE
- DECOM (2)(E) 7/8" COAX AND LEAVE IN-PLACE
- REMOVE (E) KATHREIN 742 264 ANTENNA IN POS 1 (ALL SECTORS)
- REMOVE (E) TMAS/DIPLEXERS IN POS 1 (ALL SECTORS)
- INSTALL (N) AEQK IN POS 1 (1 PER SECTOR)
- INSTALL (N) AEQU STACKED ON TOP OF AEQK IN POS 1 (1 PER SECTOR)
- USE (E) SPARE 6 AWG DC TRUNKS FOR (N) AEQK AND (N) AEQU

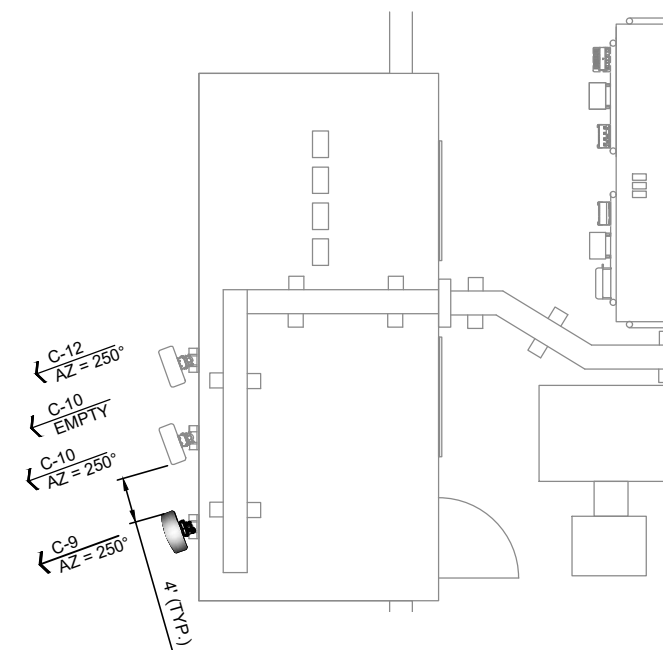

ELEVATION 107'

2 PROPOSED ANTENNA LAYOUT

SCALE: 1/4" = 1'-0"



JACOBS

Challenging today. Reinventing tomorrow.



APPROVALS

LANDLORD _____

LEASING _____

R.F. _____

ZONING _____

CONSTRUCTION _____

A & E _____

PROJECT NO: EP4TURWL

DRAWN BY: CRO

CHECKED BY: LW

SUBMITTALS	
4	11/01/22 PERMITTING COMMENTS
3	09/27/22 JX COMMENTS
2	08/23/22 ISSUED
1	06/13/22 REVISION
0	06/01/22 ISSUED
B	06/01/22 REVISION
A	04/27/22 ISSUED FOR REVIEW

THIS DOCUMENT IS THE CREATION, DESIGN, PROPERTY AND COPYRIGHTED WORK OF AT&T. WITHOUT EXPRESS WRITTEN CONSENT IS STRICTLY PROHIBITED, DUPLICATION AND USE BY GOVERNMENT AGENCIES FOR THE PURPOSE OF CONDUCTING THEIR LAWFULLY AUTHORIZED REGULATORY AND ADMINISTRATIVE FUNCTIONS ARE SPECIFICALLY ALLOWED.

FA# 10072888
 USID# 3939
 TULIP AVE
 7051 CARROL STREET
 TAKOMA PARK, MD 20912

EXISTING & PROPOSED ANTENNA LAYOUT



7150 STANDARD DR. SUITE A
HANOVER, MD 21076

Jacobs

Challenging today.
Reinventing tomorrow.

Jacobs Telecommunications, Inc.
7150 STANDARD DR. SUITE B
HANOVER, MD 21076
443.230.4400x113

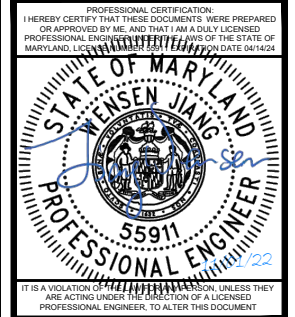

IT IS A VIOLATION OF PROFESSIONAL ENGINEERING, UNLESS THEY ARE ACTING UNDER THE DIRECTION OF A LICENSED PROFESSIONAL ENGINEER, TO ALTER THIS DOCUMENT

APPROVALS

LANDLORD _____
LEASING _____
R.F. _____
ZONING _____
CONSTRUCTION _____
A & E _____

PROJECT NO: EP4TURWL

DRAWN BY: CRO

CHECKED BY: LW

SUBMITTALS

Rev	Date	Description
4	11/01/22	PERMITTING COMMENTS
3	09/27/22	JX COMMENTS
2	08/23/22	ISSUED
1	06/13/22	REVISION
0	06/01/22	ISSUED
B	06/01/22	REVISION
A	04/27/22	ISSUED FOR REVIEW

THIS DOCUMENT IS THE CREATION, DESIGN, PROPERTY AND COPYRIGHTED WORK OF AT&T. WITHOUT EXPRESS WRITTEN CONSENT, ANY REPRODUCTION, DISTRIBUTION, OR USE OF THIS DOCUMENT IS STRICTLY PROHIBITED. DUBLICATION AND USE BY GOVERNMENT AGENCIES FOR THE PURPOSE OF CONDUCTING THEIR LAWFULLY AUTHORIZED REGULATORY AND ADMINISTRATIVE FUNCTIONS ARE SPECIFICALLY ALLOWED.

FA# 10072888
USID# 3939
TULIP AVE
7051 CARROL STREET
TAKOMA PARK, MD 20912

DC TRUNK CABLE
CALCULATOR

E-2

75

Model: NetSim 7217100 - 522121000 w/26-position Panels

Number of Radio Types: No Fixed Generator Onsite

Radio Type #1: Converters per trunk feed: 0

Select Installation type: Unlocked Locked

Trunk Cable Length - one-way: 260 ft

Trunk Cable Size (AWG - 4, 6, 8): 6

Jumper Cable Length - one-way: 15 ft

Jumper Cable Size (AWG - 8, 10, or 12): 8

Total Quantity of RRU Trunk Feeds: 2

Radio: No Yes (All Cells AECN, B77)

RRU Trunk Feed Peak DC Input Power (W): 931

Radio Type #2: Converters per trunk feed: 0

Select Installation type: Unlocked Locked

Trunk Cable Length - one-way: 260 ft

Trunk Cable Size (AWG - 4, 6, 8): 6

Jumper Cable Length - one-way: 15 ft

Jumper Cable Size (AWG - 8, 10, or 12): 8

Total Quantity of RRU Trunk Feeds: 2

Radio: No Yes (enter power level)

RRU Trunk Feed Peak DC Input Power (W): 931

Fill in the yellow highlighted cells as appropriate. See definitions for each cell on the Notes tab.

TOTAL # OF POWER EXTEND CONVERTERS=0

= CB, Fuse, or End of Panel

= Do Not Use

Yes Up-converters or Allocation

Without Converter	With Converter
40.09	48.07
23.22	19.37
1207.6	1123.4
3622.9	3370.3
69.7	66.1
N/A	0
N/A	0
N/A	0

NOTE: No Converter(s) are needed because the voltage drop without converters is OK. See detailed information to the right.

Without Converter	With Converter
45.12	52.04
13.41	11.63
697.4	674.5
2092.2	2023.6
525	475
525	475
650	650

NOTE: No Converter(s) are needed because the voltage drop without converters is OK. See detailed information to the right.

RRU Trunk Feed Busy Hour Input Power (W)	605	RRU Voltage (VDC) at Min Source Voltage and Peak Power	40.09	48.07
Minimum Source Voltage (V)	62	RRU Trunk Feed Current (A) at Min Source Voltage and Peak Power	23.22	19.37
Converter Output Voltage (V)	58	Source Power (W) per RRU Trunk Feed at Min Source V and Peak RRU Power	1207.6	1123.4
Minimum RRU Operating Voltage (VDC)	46	Total Source Power (W) at Min Source Voltage and Peak RRU Power	3622.9	3370.3
Peak Power Rating of Power Extend Conv (W)	1000	Peak Power System Current (A) Required for RRU's	69.7	66.1
Total Cable loop length	1150 ft	Qty of Power Extend Converters Req'd per RRU Trunk Feed	N/A	0
Cable Resistance (Ohms)	0.5129	Qty of Power Extend Converters Req'd per Site	N/A	0
		# of Total Bullet Positions Required	N/A	0

RRU Trunk Feed Busy Hour Input Power (W)	605	RRU Voltage (VDC) at Min Source Voltage and Peak Power	40.09	48.07
Minimum Source Voltage (V)	62	RRU Trunk Feed Current (A) at Min Source Voltage and Peak Power	23.22	19.37
Converter Output Voltage (V)	58	Source Power (W) per RRU Trunk Feed at Min Source V and Peak RRU Power	1207.6	1123.4
Minimum RRU Operating Voltage (VDC)	46	Total Source Power (W) at Min Source Voltage and Peak RRU Power	3622.9	3370.3
Peak Power Rating of Power Extend Conv (W)	1000	Peak Power System Current (A) Required for RRU's	69.7	66.1
Total Cable loop length	1150 ft	Qty of Power Extend Converters Req'd per RRU Trunk Feed	N/A	0
Cable Resistance (Ohms)	0.5129	Qty of Power Extend Converters Req'd per Site	N/A	0
		# of Total Bullet Positions Required	N/A	0

RRU Voltage (VDC) at Min Source Voltage and Busy Hour	45.12	52.04	Power Extend Converter Average Power Level Above which a Space is required Between Each 4 Units (W)	250
RRU Trunk Feed Current (A) at Min Source Voltage and Busy Hour	13.41	11.63	Power Extend Converter Average Power Level Above which a Space is required Between Each 3 Units (W)	475
Source Power (W) at Min Source V and Busy Hour per RRU Trunk Feed	697.4	674.5	Power Extend Converter Average Power Level Above which a Space is required Between Each 2 Units (W)	525
Total Source Power (W) at Min Source Voltage and Busy Hour	2092.2	2023.6	Power Extend Converter Average Power Level Above which a Space is required Between Each Unit (W)	650

NOTES:

- EXOTHERMIC WELD (2) TWO, #2 AWG BARE TINNED SOLID COPPER CONDUCTORS TO GROUNDING BAR. ROUTE CONDUCTORS TO BURIED GROUNDING RING AND PROVIDE PARALLEL EXOTHERMIC WELD.
- ALL GROUNDING BARS SHALL BE STAMPED IN TO THE METAL "IF STOLEN DO NOT RECYCLE." THE CONTRACTOR SHALL USE PERMANENT MARKER TO DRAW THE LINES BETWEEN EACH SECTION AND LABEL EACH SECTION ("P", "A", "N", "I") WITH 1" HIGH LETTERS.
- ALL HARDWARE SHALL BE STAINLESS STEEL 3/8" DIAMETER OR LARGER. ALL HARDWARE 18-8 STAINLESS STEEL INCLUDING LOCK WASHERS, COAT ALL SURFACES WITH AN ANTI-OXIDANT COMPOUND BEFORE MATING.
- FOR GROUND BOND TO STEEL ONLY: INSERT A CADMIUM FLAT WASHER BETWEEN LUG AND STEEL, COAT ALL SURFACES WITH AN ANTI-OXIDANT COMPOUND BEFORE MATING.
- DO NOT INSTALL CABLE GROUNDING KIT AT A BEND AND ALWAYS DIRECT GROUNDING CONDUCTOR DOWN TO GROUNDING BUS.
- NUT & WASHER SHALL BE PLACED ON THE FRONT SIDE OF THE GROUNDING BAR AND BOLTED ON THE BACK SIDE. INSTALL BLACK HEAT-SHRINKING TUBE, 600 VOLT INSULATION, ON ALL GROUNDING TERMINATIONS. THE INTENT IS TO WEATHERPROOF THE COMPRESSION CONNECTION.
- SUPPLIED AND INSTALLED BY CONTRACTOR.
- THE CONTRACTOR SHALL BE RESPONSIBLE FOR INSTALLING ADDITIONAL GROUNDING BAR AS REQUIRED, PROVIDING 50% SPARE CONNECTION POINTS.
- ENSURE THE WIRE INSULATION TERMINATION IS WITHIN 1/8" OF THE BARREL (NO SHINERS).

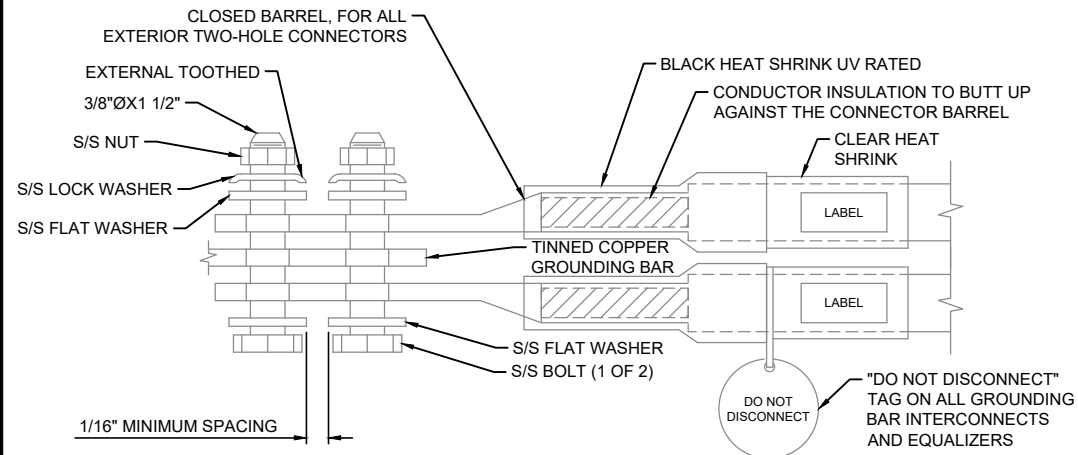

GROUNDING NOTES:

- TOWER GROUNDING BAR: EXTEND (2) #2 AWG TINNED CU WIRE FROM BURIED GROUND RING UP TO THE TOWER GROUND BAR AND MAKE A MECHANICAL CONNECTION. SECURE GROUND BAR DIRECTLY TO TOWER WITH STAINLESS STEEL MOUNTING MATERIAL.
- ANTENNA GROUNDING BAR: ANDREW CORPORATION PART #UGBKIT-0424-T MOUNT GROUND BAR DIRECTLY TO TOWER. SECURE TO TOWER WITH STAINLESS STEEL MOUNTING MATERIAL.
- GROUNDING BAR: LOCATED CLOSE TO GRADE LOCK BOX TESSCO PART #351546: INSTALL PER MANUFACTURER GUIDELINES.
- EXOTHERMIC OR COMPRESSION CONNECTION FOR PIPE MOUNT TO ANTENNA ROUTE CONDUCTOR TO NEAREST GROUNDING BAR SO THE GROUNDING CONDUCTORS PROVIDE A STRAIGHT DOWNWARD PATH TO GROUND. USE #2 AWG SOLID TINNED COPPER CONDUCTOR. GROUNDING CONNECTION SHALL BE LOCATED AT THE TOP 2" OF PIPE.
- ALL GROUNDING CONDUCTORS SHALL BE #2 AWG COPPER TINNED UNLESS NOTED OTHERWISE.
- ALL GROUNDING CONDUCTORS SHALL PROVIDE A STRAIGHT DOWNWARD PATH TO GROUND WITH GRADUAL BEND AS REQUIRED. GROUND WIRES SHALL NOT BE LOOPED OR SHARPLY BENT.
- KOPR-SHIELD ANTI-OXIDATION COMPOUND SHALL BE USED ON ALL COMPRESSION GROUNDING CONNECTIONS.
- ALL EXOTHERMIC CONNECTIONS SHALL BE INSTALLED UTILIZING THE PROPER CONNECTION/MOLD AND MATERIALS FOR THE PARTICULAR APPLICATION.
- ALL BOLTED GROUNDING CONNECTIONS SHALL BE INSTALLED WITH AN EXTERNAL TOOTHED LOCK WASHER. GROUNDING BUS BARS MAY HAVE PRE-PUNCHED HOLES OR TAPPED HOLES. ALL HARDWARE SHALL BE SECURITY TORQUE HARDWARE 3/8" STAINLESS STEEL.
- EXTERNAL GROUNDING CONDUCTOR SHALL NOT BE INSTALLED OR ROUTED THROUGH HOLES IN ANY METAL OBJECTS, CONDUITS, OR SUPPORTS TO PRECLUDE ESTABLISHING A MAGNETIC CHOKE POINT.
- PLASTIC CLIPS SHALL BE USED TO FASTEN AND SUPPORT GROUNDING CONDUCTORS. FERROUS METAL CLIPS WHICH COMPLETELY SURROUND THE GROUNDING CONDUCTOR SHALL NOT BE USED.
- IF COAX ON ICE BRIDGE IS MORE THAT 6' FROM THE GROUND BAR AT THE BASE OF THE TOWER, A SECOND GROUND BAR WILL BE NEEDED AT THE END OF THE ICE BRIDGE RUN TO GROUND THE COAX GROUND KIT AND THE IN-LINE SURGE ARRESTORS (SURGE ARRESTORS INSTALLED BY LUCENT ONLY HAVE 6' GROUND TAILS).
- CONTRACTOR SHALL REPAIR/PLACE EXISTING GROUNDING SYSTEM COMPONENTS DAMAGED DURING CONSTRUCTION AT THE CONTRACTORS EXPENSE.
- DO NOT ALLOW THE COPPER CONDUCTOR TO TOUCH THE GALVANIZED GUY WIRE AT THE CONNECTION POINT OR AT ANY OTHER POINT. NO EXOTHERMICALLY WELDED CONNECTION SHALL BE MADE TO THE GUY WIRE.
- CONTRACTOR SHALL VERIFY EXISTING SECTOR GROUNDING CONDITION AND GROUND THE PROPOSED EQUIPMENT IN THE SAME MANNER. A PROPOSED SECTOR GROUND BAR SHALL BE INSTALLED IF REQUIRED.

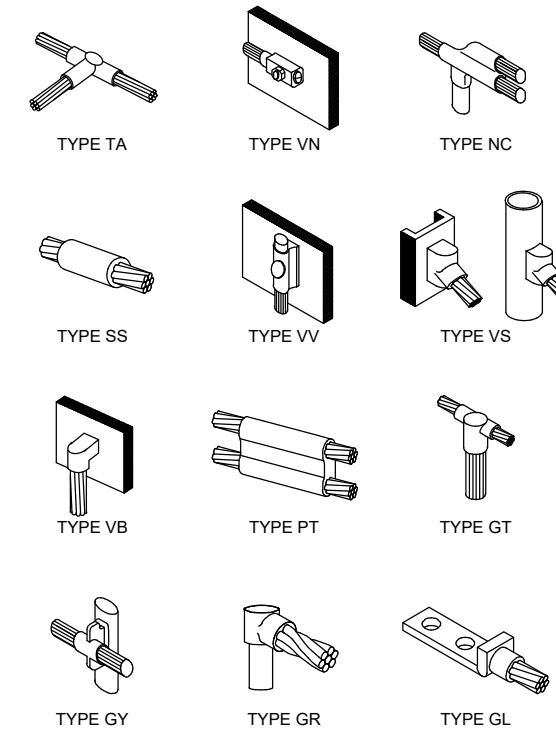

1 EXTERIOR TWO HOLE LUG DETAIL

SCALE: N.T.S.

2 GROUNDING BAR DETAIL

SCALE: N.T.S.

3 GROUNDING DETAILS

SCALE: N.T.S.

NOTES:

- CONTRACTOR TO VERIFY EXISTENCE AND LOCATIONS OF SECTOR GROUND BARS AND PROVIDE PROPOSED SECTOR GROUND BARS AS REQUIRED.
- CONTRACTOR TO PROVIDE #2 AWG BARE COPPER DOWN-LEADS FROM PROPOSED SECTOR GROUND BARS TO EXISTING TOWER GROUND BAR.
- CONTRACTOR SHALL VERIFY ALL PROPOSED/USED/OCCUPIED PIPE MOUNTS ARE GROUNDED BACK TO THE SECTOR GROUND BAR. IF GROUNDING DOES NOT EXIST FROM THE PIPE MOUNT TO THE SECTOR GROUND BAR, CONTRACTOR SHALL FURNISH ALL MATERIALS AS REQUIRED.
- ALL CABLE CONNECTIONS TO BE WEATHERPROOFED PER MANUFACTURER INSTRUCTION.

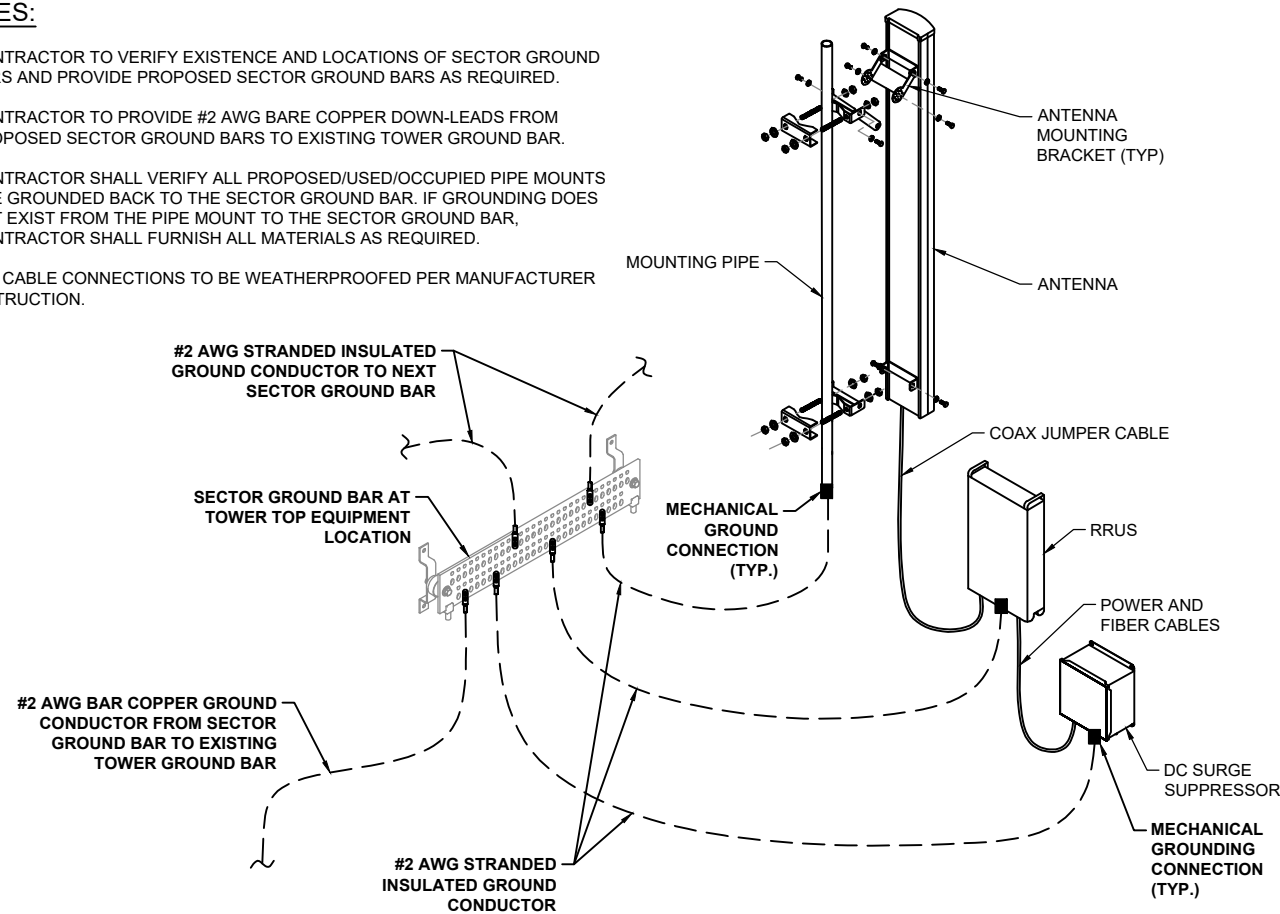

4 TYPICAL ANTENNA GROUNDING SCHEMATIC

SCALE: N.T.S.

5 DETAIL NOT USED

SCALE: N.T.S.



APPROVALS

LANDLORD _____

LEASING _____

R.F. _____

ZONING _____

CONSTRUCTION _____

A & E _____

PROJECT NO: EP4TURWL

DRAWN BY: CRO

CHECKED BY: LW

SUBMITTALS	
4	11/01/22 PERMITTING COMMENTS
3	09/27/22 JX COMMENTS
2	08/23/22 ISSUED
1	06/13/22 REVISION
0	06/01/22 ISSUED
B	06/01/22 REVISION
A	04/27/22 ISSUED FOR REVIEW

THIS DOCUMENT IS THE CREATION, DESIGN, PROPERTY AND COPYRIGHTED WORK OF AT&T. WITHOUT EXPRESS WRITTEN CONSENT IS STRICTLY PROHIBITED, DUPLICATION AND USE BY GOVERNMENT AGENCIES FOR THE PURPOSE OF CONDUCTING THEIR LAWFULLY AUTHORIZED REGULATORY AND ADMINISTRATIVE FUNCTIONS ARE SPECIFICALLY ALLOWED.

FA# 10072888
 USID# 3939
 TULIP AVE
 7051 CARROL STREET
 TAKOMA PARK, MD 20912

GROUNDING DETAILS

RFDS ID: 4445171

ANTENNA POSITION	ANTENNA MODEL	ANTENNA MAKE	AZIMUTH	RAD CENTER FT. AGL.	TMAS, RRHS & DIPLEXERS		COAXIAL FEEDER	
					MODEL	SIZE	LENGTH	
#1	AEQK+AEQU STACKED (71.0"x17.7"x9.5") (198.4 LBS)	NOKIA	25°	AEQU: 116'-9" AEQK: 113'-2"	-	SHARED FIBER	60'	
#2	NNHH-65A-R4 (55.1"x19.6"x7.8") (68.3 LBS)	COMMSCOPE	25°	115'	(1) RRH 4T4R B12/14 320W AHLBA (1) RRH 4T4R B25/66 320W AHFIB	SHARED FIBER	60'	
#3	-	-	-	-	-	-	-	
#4	NNHH-65A-R4 (55.1"x19.6"x7.8") (68.3 LBS)	COMMSCOPE	25°	115'	(1) RRH 4T4R B5/29 240W AHBCB (1) RRH4x25-WCS-4R	SHARED FIBER	60'	
#5	AEQK+AEQU STACKED (71.0"x17.7"x9.5") (198.4 LBS)	NOKIA	140°	AEQU: 130'-9" AEQK: 127'-2"	-	SHARED FIBER	130'	
#6	NNHH-65A-R4 (55.1"x19.6"x7.8") (68.3 LBS)	COMMSCOPE	140°	129'	(1) RRH 4T4R B12/14 320W AHLBA (1) RRH 4T4R B25/66 320W AHFIB	SHARED FIBER	130'	
#7	-	-	-	-	-	-	-	
#8	NNHH-65A-R4 (55.1"x19.6"x7.8") (68.3 LBS)	COMMSCOPE	140°	129'	(1) RRH 4T4R B5/29 240W AHBCB (1) RRH4x25-WCS-4R	SHARED FIBER	130'	
#9	AEQK+AEQU STACKED (71.0"x17.7"x9.5") (198.4 LBS)	NOKIA	250°	AEQU: 108'-9" AEQK: 105'-2"	-	SHARED FIBER	130'	
#10	NNHH-65A-R4 (55.1"x19.6"x7.8") (68.3 LBS)	COMMSCOPE	250°	107'	(1) RRH 4T4R B12/14 320W AHLBA (1) RRH 4T4R B25/66 320W AHFIB	SHARED FIBER	130'	
#11	-	-	-	-	-	-	-	
#12	NNHH-65A-R4 (55.1"x19.6"x7.8") (68.3 LBS)	COMMSCOPE	250°	107'	(1) RRH 4T4R B5/29 240W AHBCB (1) RRH4x25-WCS-4R	SHARED FIBER	130'	

NOTES:

1. VERIFY ANTENNA DIMENSIONS WITH MANUFACTURER.
2. ALL NEW ANTENNAS SHALL RECEIVE ANTENNA MOUNTING KIT FOR 2 TO 4.5 O.D. MAST (QTY. 2)
3. ALL NEW ANTENNAS SHALL RECEIVE A LOCKING TILT MOUNT KIT 0-13 DEGREES DOWNTILT ANGLE
4. VERIFY FINAL ANTENNA MODEL WITH CURRENT VERSION OF THE AT&T RFDS.

AT&T CABLING:
 (9) ANTENNAS
 (12) RRHS
 (2) WCS FILTERS
 (3) DC9 BOXES
 (8) 1-5/8" COAX
 (4) 7/8" COAX
 (9) 0.96" DC TRUNKS (6 AWG)
 (3) 0.4" FIBER TRUNKS (24 PAIR)

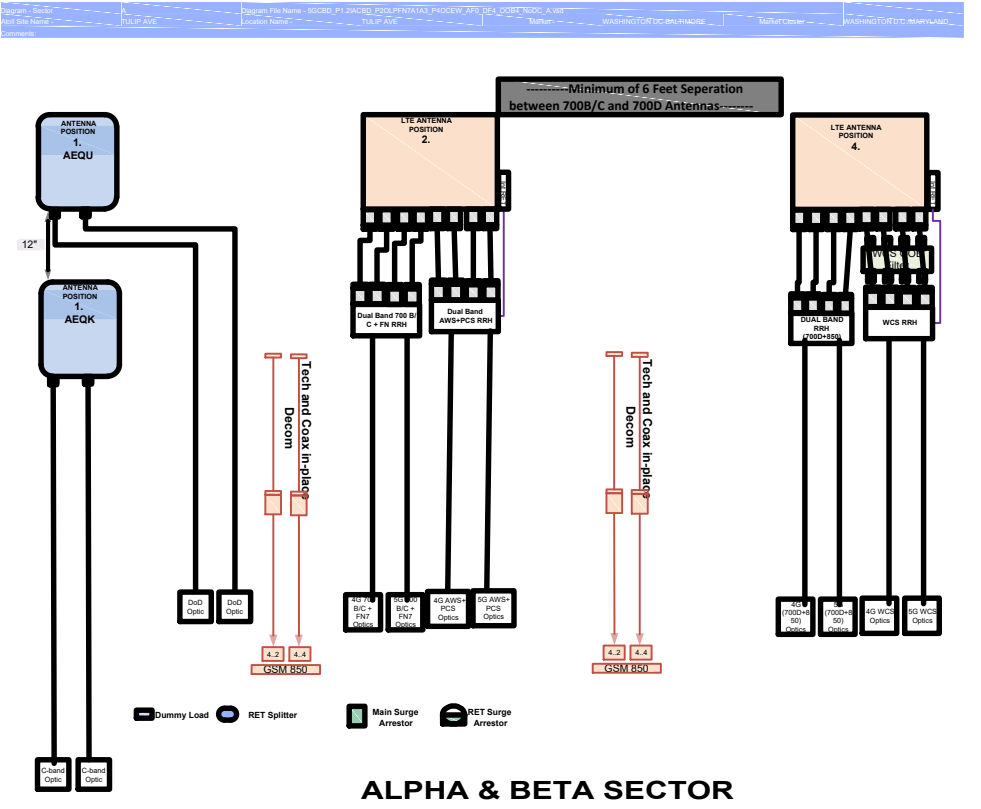

ALPHA & BETA SECTOR

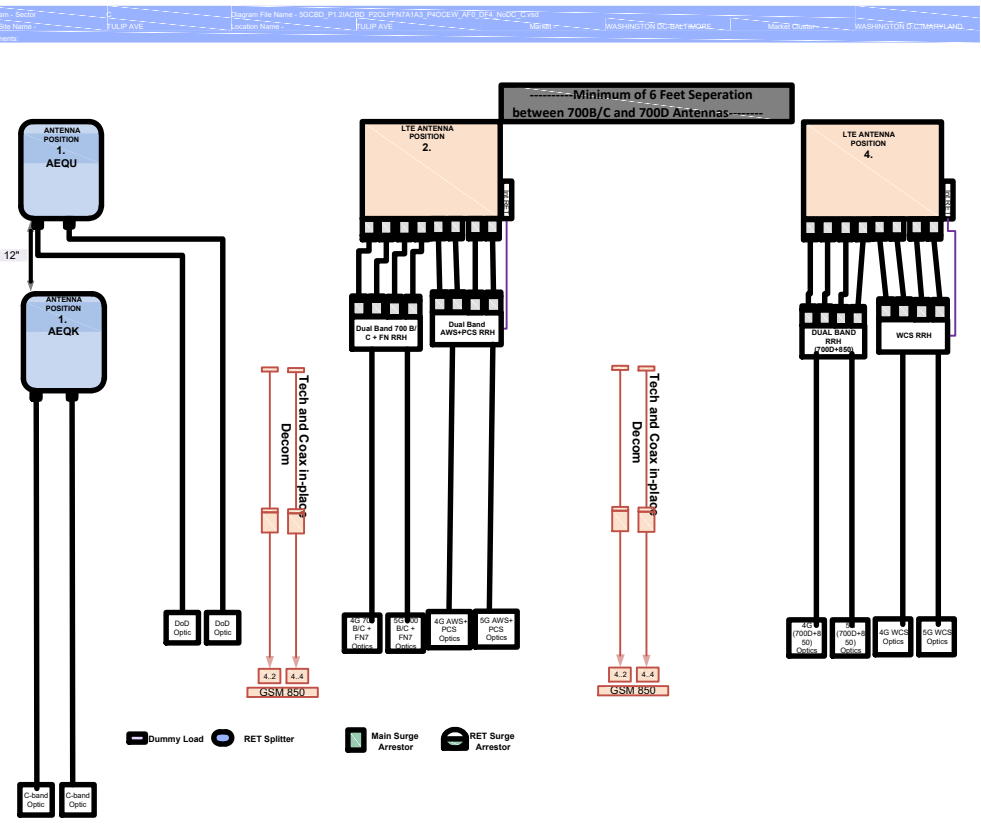

GAMMA SECTOR

NOTES:

1. CONTRACTOR TO VERIFY FINAL RF CONFIGURATION AND NOTIFY CARRIER AND ENGINEER WITH ANY DISCREPANCIES PRIOR TO THE INSTALLATION.
2. PLUMBING DIAGRAM SHOWN IS BASED ON APPROVED FINAL RFDS ID: 4445171 DATED ON 02/25/22.



APPROVALS

LANDLORD _____

LEASING _____

R.F. _____

ZONING _____

CONSTRUCTION _____

A & E _____

PROJECT NO: EP4TURWL

DRAWN BY: CRO

CHECKED BY: LW

SUBMITTALS	
4	11/01/22 PERMITTING COMMENTS
3	09/27/22 JX COMMENTS
2	08/23/22 ISSUED
1	06/13/22 REVISION
0	06/01/22 ISSUED
B	06/01/22 REVISION
A	04/27/22 ISSUED FOR REVIEW

THIS DOCUMENT IS THE CREATION, DESIGN, PROPERTY AND COPYRIGHTED WORK OF AT&T WIRELESS. ANY DUPLICATION OR USE WITHOUT EXPRESS WRITTEN CONSENT IS STRICTLY PROHIBITED. DUPLICATION AND USE BY GOVERNMENT AGENCIES FOR THE PURPOSE OF CONDUCTING THEIR LAWFULLY AUTHORIZED REGULATORY AND ADMINISTRATIVE FUNCTIONS ARE SPECIFICALLY ALLOWED.

FA# 10072888
 USID# 3939
 TULIP AVE
 7051 CARROL STREET
 TAKOMA PARK, MD 20912

ANTENNA CHART & PLUMBING DIAGRAM

RF-1
 77



Field	Length	Description		
USID	6	Six characters that defined the sites USID. USID's less than 6 characters in length are preceded with 0's (zeros) (example:003031)		
Cellid1	1	Allowed Value Description		
		A Alpha		
		B Beta		
		C Gamma		
Cellid2	1	D Delta		
		E Epsilon		
Cellid3	1	F Zeta		
AntPos	1	- No Transmitter connected to this port		
		Allowed Value Description		
		1 Antenna Position 1 on this face		
		2 Antenna Position 2 on this face		
		:	Antenna Position x on this face	
		:	Antenna Position x on this face	
		9 Antenna Position 9 on this face		
		-	Antenna Position unknown	
		FreqBand	1	Allowed Value Description
				2 2100 MHz (AWS1) only
3 2300 MHz (WCS) only				
6 Band 66 (AWS3) only				
7 700 MHz B & C Band only				
8 850 MHz only				
9 1900 MHz (PCS)				
A 2100 MHz (AWS1) & Band 66 (AWS3) combined				
B 1900 MHz (PCS) & Band 66 (AWS3) combined				
C 2100 MHz (AWS1) & Band 66 (AWS3) & 2300 MHz (WCS) combined				
D 1900 MHz (PCS) & 2100 MHz (AWS1) combined				
E 2300 MHz (WCS) & Band 66 (AWS3) combined				
F 1900 MHz (PCS) & 2300 MHz (WCS) combined				
G 1900 MHz (PCS) & 2100 MHz (AWS1) & Band 66 (AWS3) combined				
H 2100 MHz (AWS1) & 2300 MHz (WCS) combined				
I 1900 MHz (PCS) & 2300 MHz (WCS) & Band 66 (AWS3) combined				
J 1900 MHz (PCS) & 2100 MHz (AWS1) & 2300 MHz (WCS) combined				
K 700 MHz B & C Band & 850 MHz combined				
M 1900 MHz (PCS) & 2100 MHz (AWS1) & Band 66 (AWS3) & 2300 MHz (WCS) combined				
P upper 700 MHz - Band 14 (FirstNet)				
Q 700 MHz D & E Band only				
R 700 MHz B & C & Band 14 (FirstNet) & 850 MHz combined				
S 700 MHz B & C & 700 MHz D & E & 850 MHz combined				
T Tri-Band: Band 12 (700 MHz B&C), Band 14 (FirstNet), and Band 29 (700 MHz D&E)				
U 700 MHz B & C & 700 MHz D & E & Band 14 (FirstNet) & 850 MHz combined				
W 700 MHz D & E & Band 14 (FirstNet) combined				
X 700 MHz B & C & Band 14 (FirstNet) combined				
Y 700 MHz D & E & 850 MHz combined				
Z Band 14 (FirstNet) & 850 MHz combined				
-	No Frequency Assigned "not-in-use"			

Field	Length	Description
Tech	1	Allowed Value Technology / Technology Combination
		F License protection/rct compliance/rwll
		G Reserved
		J LTE-5G NR
		K UMTS-LTE-5G NR
		L LTE
		N None/Reserved
		U UMTS
		V UMTS-LTE
		Y UMTS-5G NR
		H Reserved
		M Exception
		P Reserved
		Q Reserved
		R 5G NR
		S Reserved
T Reserved		

Delimiter	13th character
-	Delimiter
B	Border Control
C	CGSA
W	WCS in combination with other bands
P	License Protection
O	Optimized
Delimiter	14th character
-	Delimiter
Z	Programming Code for RET validated

2.3.1 Dual Broadband Antennas - TYPE 1

Powerwave, Kathrein and older Andrew antennas will be recognized by a RET controller as TYPE1 Antenna Line Devices. These require 2 AISG connections. One connection will be from the AISG source (RRH, TMA, RET Controller or Homerun Cable) to the first RET motor and the second connection will be from RET motor 1 to RET motor 2.

Connections from the RET controller will be made to the male connector of the RET motor. Appropriate daisy chain connection will then have to be made to the next RET motor. Figure 5 below is a Powerwave antenna, but the Kathrein will be very similar in appearance and connection.

For all Type 1 dual broadband antennas, the daisy chain connection should be made and both RET motors should be configured in the OSS, even if the high band RET motor is not to be utilized until future AWS launches.

Dual Broadband Antennas - TYPE 17

Newer Andrew antennas and all KMW antennas will be recognized by RET controllers as TYPE17 Antenna Line Devices since there are multiple ALDs on one bus. These antennas only require one AISG connection since both RET motors are inside the antenna. Connections from the RET controller will be made to the male connector of the RET/AISG Antenna Port. Figure 7 below is an Andrew antenna, but the KMW antenna will be very similar in appearance and connection.

Below is the list of approved RET Type 17 antennas as per 6/29/2011. Andrew will continue to phase out older models which are Type 1 with newer models that will be Type 17.

Vendor	Frequency Band	HBW	Length	Model
Andrew	Dual Broadband	65°	6'	SBNH-1D6565B
Andrew	Dual Broadband	65°	8'	SBNH-1D6565C
Andrew	Dual Broadband	85°	6'	SBNH-1D8565B
Andrew	Dual Broadband	85°	8'	SBNH-1D8565C
KMW	Dual Broadband	65°	4'	AM-X-CD-14-65-00T-RET
KMW	Dual Broadband	65°	6'	AM-X-CD-16-65-00T-RET
KMW	Dual Broadband	65°	8'	AM-X-CD-17-65-00T-RET
KMW	Dual Broadband	85°	4'	NOT AVAILABLE YET
KMW	Dual Broadband	85°	6'	NOT AVAILABLE YET
KMW	Dual Broadband	85°	8'	AM-X-CD-16-85-00T-RET
KMW	Single Broadband	65°	4'	AM-X-CW-14-65-00T-RET
KMW	Single Broadband	65°	6'	AM-X-CW-16-65-00T-RET
KMW	Single Broadband	65°	8'	AM-X-CW-18-65-00T-RET
KMW	Single Broadband	85°	4'	AM-X-CW-13-85-00T-RET
KMW	Single Broadband	85°	6'	AM-X-CW-15-85-00T-RET
KMW	Single Broadband	85°	8'	AM-X-CW-16-85-00T-RET

APPROVALS

LANDLORD _____
 LEASING _____
 R.F. _____
 ZONING _____
 CONSTRUCTION _____
 A & E _____

PROJECT NO: EP4TURWL

DRAWN BY: CRO

CHECKED BY: LW

SUBMITTALS	
4	11/01/22 PERMITTING COMMENTS
3	09/27/22 JX COMMENTS
2	08/23/22 ISSUED
1	06/13/22 REVISION
0	06/01/22 ISSUED
B	06/01/22 REVISION
A	04/27/22 ISSUED FOR REVIEW

THIS DOCUMENT IS THE CREATION, DESIGN, PROPERTY AND COPYRIGHTED WORK OF AT&T. WITHOUT EXPRESS WRITTEN CONSENT OF AT&T, NO PART OF THIS DOCUMENT IS TO BE REPRODUCED, COPIED, TRANSMITTED, OR IN ANY MANNER DISCLOSED TO ANY OTHER PERSON OR ENTITY. EXPRESS WRITTEN CONSENT IS STRICTLY PROHIBITED, DUPLICATION AND USE BY GOVERNMENT AGENCIES FOR THE PURPOSE OF CONDUCTING THEIR LAWFULLY AUTHORIZED REGULATORY AND ADMINISTRATIVE FUNCTIONS ARE SPECIFICALLY ALLOWED.

FA# 10072888
 USID# 3939
 TULIP AVE
 7051 CARROL STREET
 TAKOMA PARK, MD 20912

LTE RET NAMING CONVENTION

RF-3
 79



Jacobs
 Challenging today.
 Reinventing tomorrow.
 Jacobs Telecommunications, Inc.
 7150 STANDARD DR. SUITE B
 HANOVER, MD 21076
 443.230.4400x113

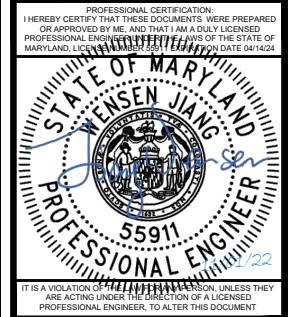

APPROVALS

LANDLORD _____
 LEASING _____
 R.F. _____
 ZONING _____
 CONSTRUCTION _____
 A & E _____

PROJECT NO: EP4TURWL

DRAWN BY: CRO

CHECKED BY: LW

SUBMITTALS

NO.	DATE	DESCRIPTION
4	11/01/22	PERMITTING COMMENTS
3	09/27/22	JX COMMENTS
2	08/23/22	ISSUED
1	06/13/22	REVISION
0	06/01/22	ISSUED
B	06/01/22	REVISION
A	04/27/22	ISSUED FOR REVIEW

THIS DOCUMENT IS THE CREATION, DESIGN, PROPERTY AND COPYRIGHTED WORK OF AT&T WIRELESS. ANY DUPLICATION OR USE WITHOUT EXPRESS WRITTEN CONSENT IS STRICTLY PROHIBITED. DUPLICATION AND USE BY GOVERNMENT AGENCIES FOR THE PURPOSE OF CONDUCTING THEIR LAWFULLY AUTHORIZED REGULATORY AND ADMINISTRATIVE FUNCTIONS ARE SPECIFICALLY ALLOWED.

FA# 10072888
 USID# 3939
 TULIP AVE
 7051 CARROL STREET
 TAKOMA PARK, MD 20912

ROOFTOP PLAN

C-1

80

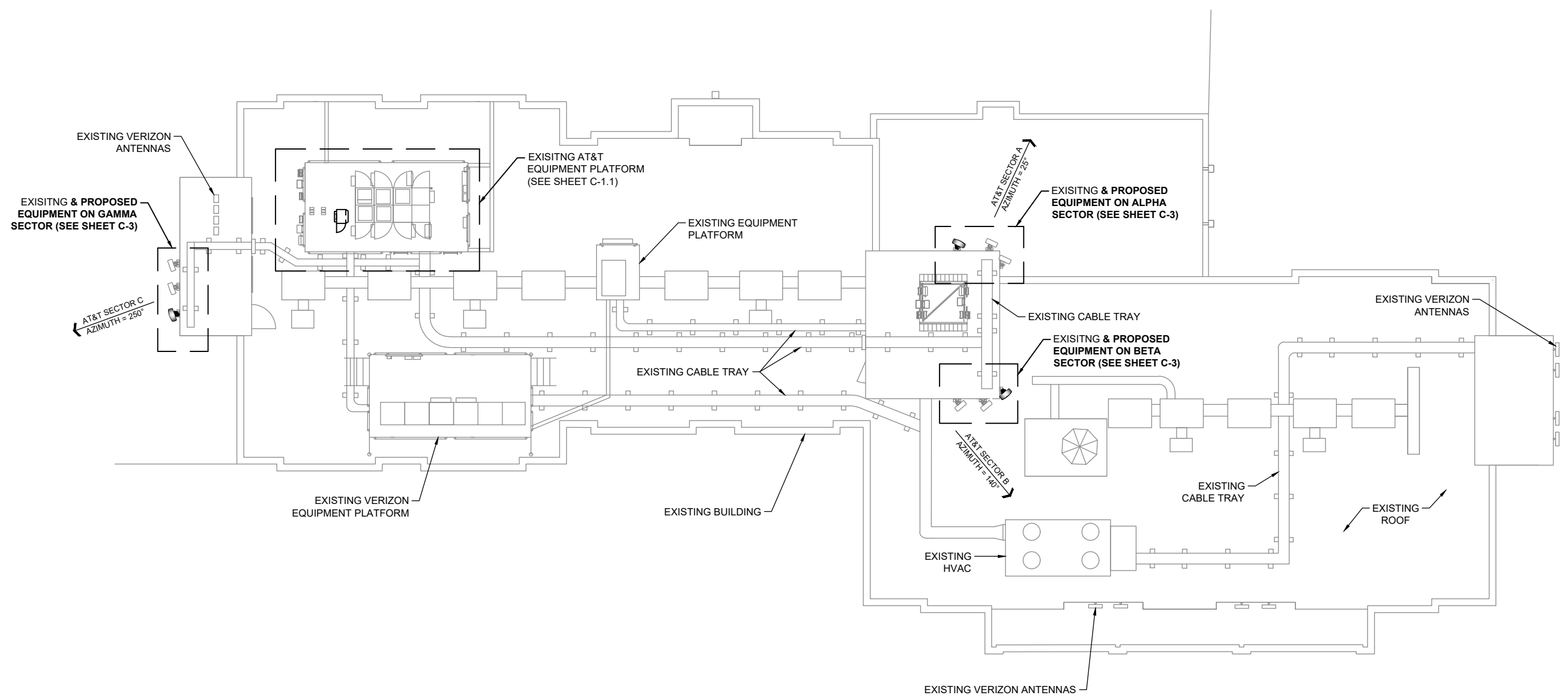



Historic Area Work Permit 1015296
7051 Carroll Ave, Takoma Park, MD 20912

Written Scope of Work

Antenna Equipment

- Decom (4) existing 1-5/8" coax and leave in place
- Decom (2) existing 7/8" coax and leave in place
- Remove (3) existing Kathrein 742 264 Antennas
- Remove existing TMA/Diplexers in Pos. 1
- Use existing space 6 AWG DC Trunks

- Install (3) proposed AEQK Antennas in Pos. 1
- Install (3) proposed AEQU Antennas in Pos. 1

Cabinet Equipment

- Decom existing UMTS
- Remove existing 9412 Cabinet
- Relocate everything inside the existing 9412 Cabinet to the proposed FLX21-V2 Cabinet

- Install (1) proposed 48V Rectifier in existing Netsure 7100 PP
- Install (4) proposed DEKA Fahrenheit HT170ET Batteries
- Install (1) proposed FLX21-V2 Cabinet
- Install (1) proposed FSM4 inside proposed FL21-V2 Cabinet
- Install (1) proposed 100A breaker
- Install (6) proposed 40A breakers
- Install (2) proposed 30A breakers